

997,903.

F. B. CLOSE.
HOISTING DRUM.
APPLICATION FILED MAR. 19, 1909.

Patented July 11, 1911.

4 SHEETS—SHEET 1.

FIG. 1.

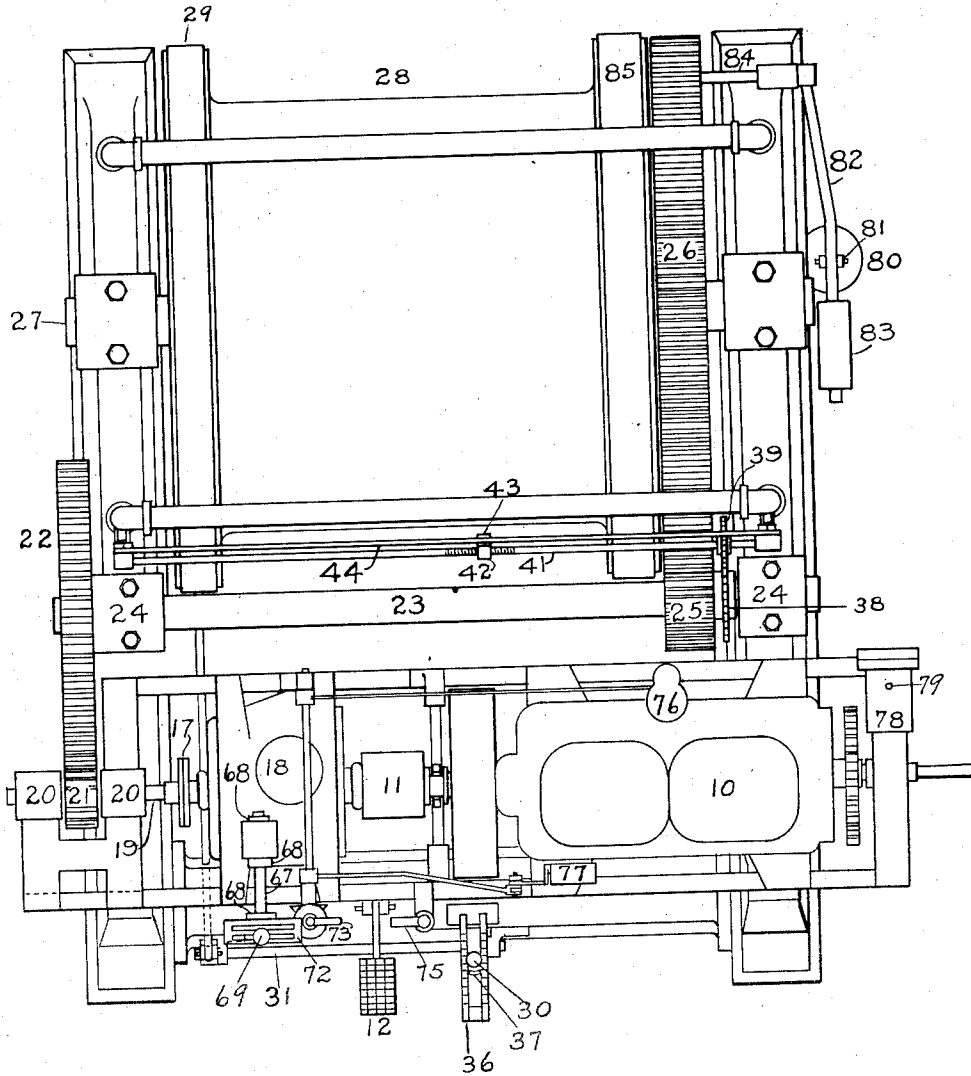

WITNESSES:

Edward Leavelle
Emma S. Caranagh

INVENTOR
Fredrick Byrley Close

BY
Clark M. Maxwell

ATTORNEY

F. B. CLOSE.
 HOISTING DRUM.
 APPLICATION FILED MAR. 19, 1909.

Patented July 11, 1911.

997,903.

4 SHEETS-SHEET 2.

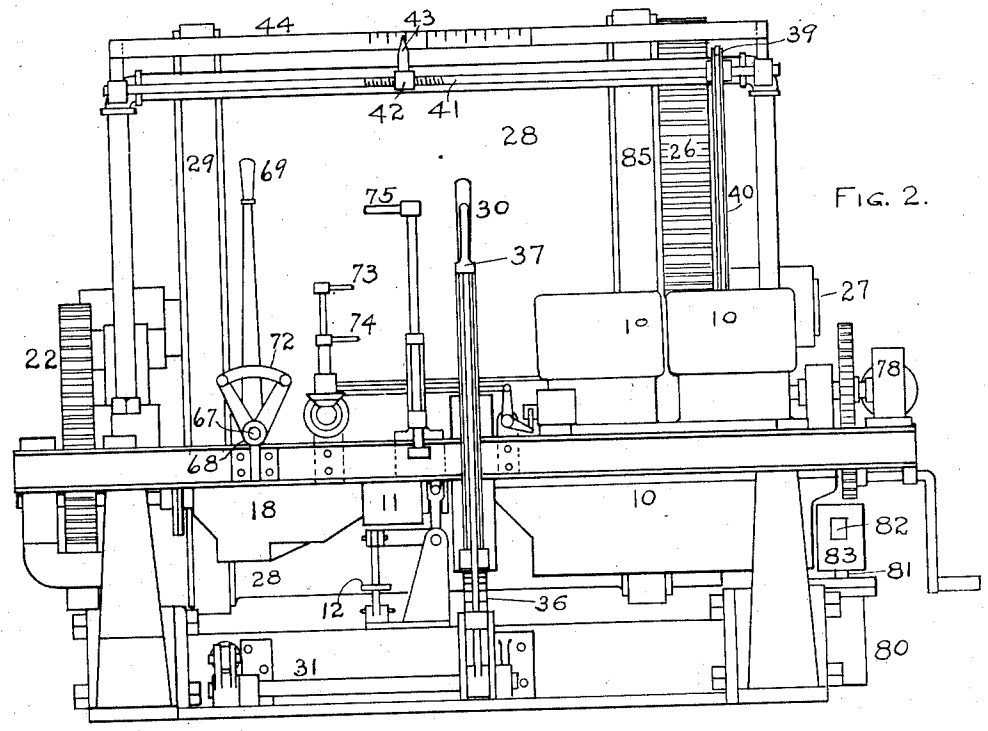

FIG. 2.

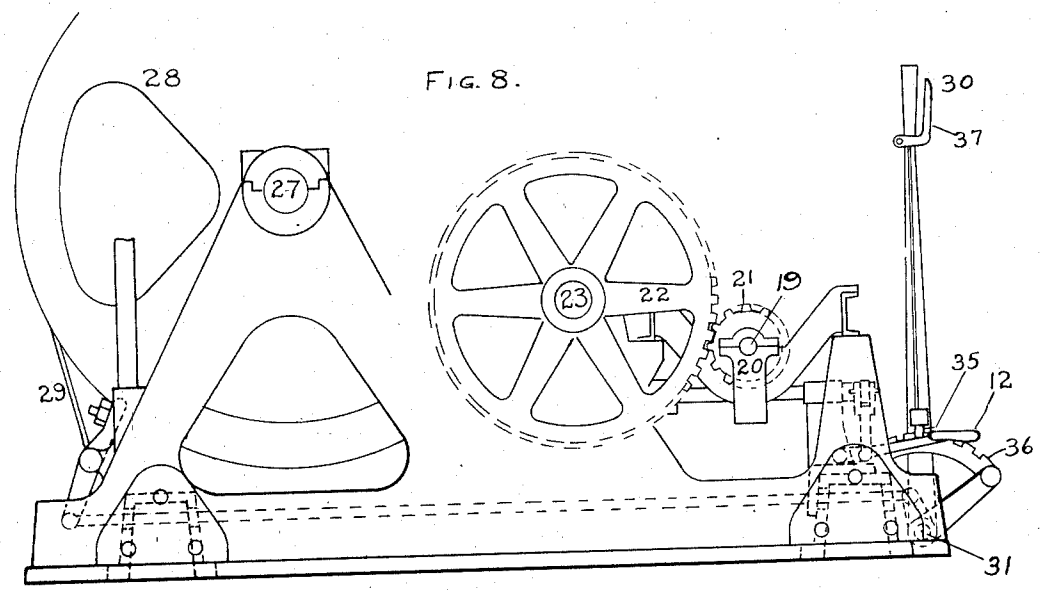

FIG. 8.

WITNESSES:

Edward Leahill
Emma S. Carranagh

INVENTOR
Frederick Byles Close
 BY *Clark C. Wood*
 ATTORNEY

997,903.

FIG. 4.

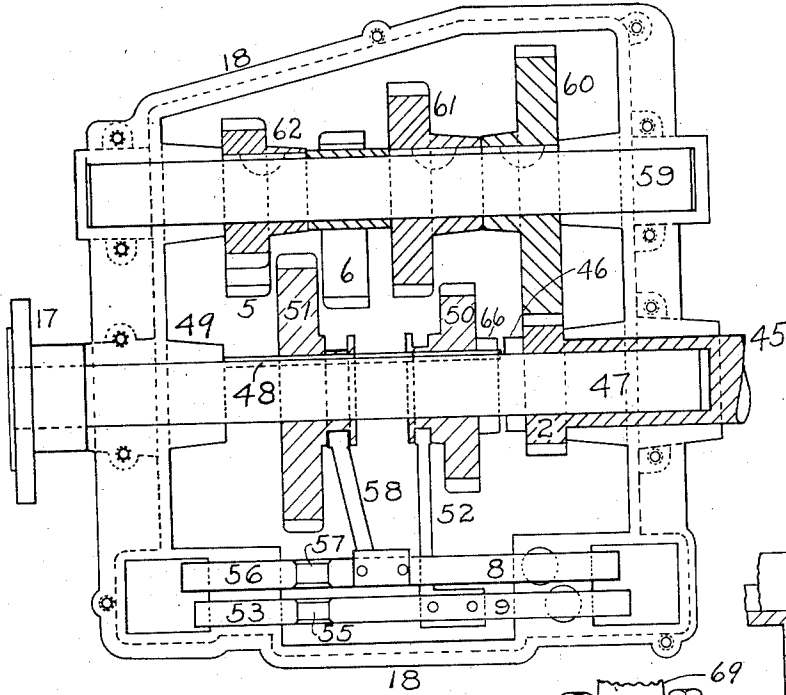

FIG. 7.

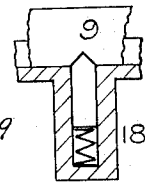

FIG. 6.

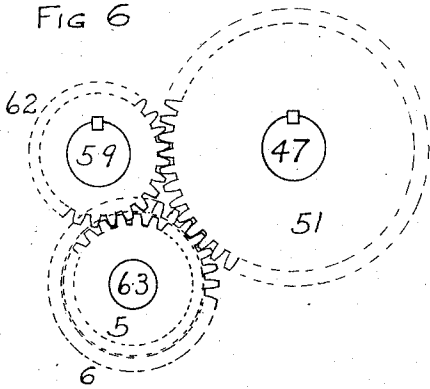
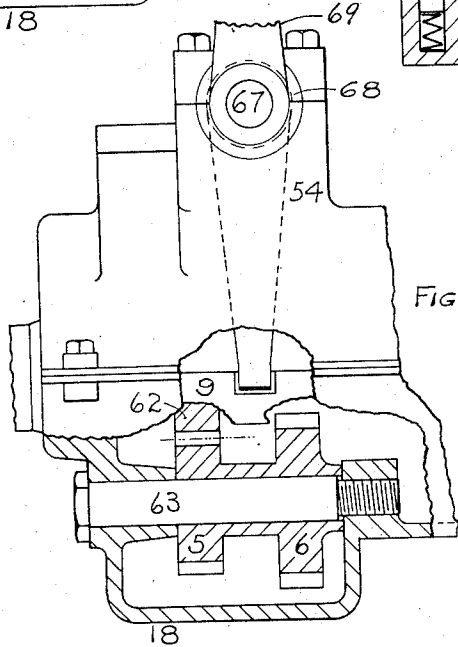

FIG. 5.



WITNESSES:

Edward Cahill
Emma S. Cavanagh

INVENTOR
Fredrick Bayley Close
BY *Clark P. Wood*

ATTORNEY

UNITED STATES PATENT OFFICE.

FREDERICK BAGLEY CLOSE, OF LOS ANGELES, CALIFORNIA, ASSIGNOR TO OLDS GAS POWER COMPANY, OF LANSING, MICHIGAN, A CORPORATION OF MICHIGAN.

HOISTING-DRUM.

997,903.

Specification of Letters Patent. Patented July 11, 1911.

Application filed March 19, 1909. Serial No. 484,367.

To all whom it may concern:

Be it known that I, FREDERICK BAGLEY CLOSE, a citizen of the United States, residing at Los Angeles, in the county of Los Angeles and State of California, have invented certain new and useful Improvements in Hoisting-Drums, of which the following is a specification.

My invention relates to hoisting drums, and its purpose is to make a drum which shall be capable of being operated at varying speeds, without changing the speed of the motor, which shall be much lighter than the ordinary hoisting apparatus of the same power, and which shall be more powerful than such devices constructed in the ordinary way.

In the drawings Figure 1 shows a plan view taken from above; Fig. 2, an elevation from the front; Fig. 3, an elevation from the right hand side; Fig. 4, a plan view of the speed changing mechanism. Figs. 5, 6, 7, and 8 are detailed views, illustrating various features of the construction.

In the drawings, 10, is a motor, which may be of any preferred style. In this case I have employed an ordinary four-cylinder gasolene engine, which is the motive power I at present prefer. The motor is connected with the speed changing mechanism, 18, by a friction clutch, 11, which may be of any approved style, operated by a foot-lever, 12, connected with the clutch by suitable transmitting links and levers. The preferred construction of the speed changing device is shown in Figs. 4, 5, 6, and 7, which will be more fully explained farther on. A coupling, 17, connects the speed changing mechanism, 18, to a shaft, 19, revolving in bearings, 20. A pinion, 21, is keyed to the shaft and meshes with a gear, 22, mounted on a shaft, 23, revolving in bearings, 24. A pinion, 25, is mounted near the end of the shaft, 23, and meshes with a gear, 26. Mounted on the shaft, 27, with the gear, 26, is a winding drum, 28. The drum, 28, is controlled by two brakes, one a hand brake, 29, operated by a hand lever, 30, through a shaft, 31, and suitable intermediate connections. A dog, 35, engaging with a ratchet arc, 36, and released by a hand-lever, 37, serves to hold the brake in position when set. The other, an air-brake, 85, operated by the lever, 82, piston, 81, and cylinder, 80, and supplied with air from the pump and

reservoir, 78, through the pipe, 77. A sprocket, 38, mounted on the shaft, 23, operates by means of a chain, 40; a similar sprocket, 39, mounted on a screw, 41. A nut, 42, carrying a pointer, 43, travels along this screw in front of a gage, 44, and by its position indicates the amount of cable wound on the drum.

So far as I am aware, it is new in the art to provide means for changing the speed of operation of hoisting drums without changing the speed of the motor, and I, therefore, do not desire to limit myself to any particular style of speed changing mechanism, or arrangement of parts therein, but I at present prefer the construction shown in Figs. 4, 5, 6, and 7, which is as follows: From the friction clutch, 11, a sleeve, 45, extends into the speed changing mechanism, 18, carrying at its inner extremity a pinion, 2, also a common square jaw clutch, 46. A shaft, 47, on which is a feather key, 48, revolves at one end in the sleeve, 45, and at the other in a bearing, 49. The shaft, 47, is connected to the shaft, 19, by a coupling, 17, as already stated. Two gear wheels, 50 and 51, are mounted on the shaft, 47, so as to slide along it, but are caused to revolve with it by the key, 48. The gear wheel, 50, can be moved along the shaft by means of the arm, 52, attached to the slide, 53, operated by a lever, 54, engaging in a notch, 55, in the slide in a manner to be more fully explained farther on. A similar slide, 56, provided with a notch, 57, and an arm, 58, serves to move the gear, 51, along the shaft, 47. An auxiliary shaft, 59, revolving in bearings at its extremities has secured to it three gears, 60, 61, and 62. A second auxiliary, or reversing shaft, 63, has two gears, 5 and 6, either mounted on, or integrally formed with, a sleeve which reverses on the shaft. The gear, 50, carries on its right hand face, a clutch, 66, adapted to engage with the clutch, 46, on the pinion, 2. When the gear, 50, is forced to its greatest distance to the right, the jaws, 66 and 46, will interlock and the shaft, 47, will be driven directly with the full speed of the motor, thus giving the highest speed to the drum. The pinion, 2, will then drive the shaft, 59, as an idler. When the gear, 50, is carried over toward the left, it will engage with the gear, 61, on the shaft, 59, and the shaft, 47, will then be driven by means

of the pinion, 2, and the gears, 60, 61, and 50, giving an intermediate speed of the drum. When the gear, 51, is moved over toward the left, it engages with the gear, 62, on the shaft, 59, and the shaft, 47, will then be driven through the gears, 2, 60, 62, and 51, giving the slowest speed of the drum, while if the gear, 51, is moved over toward the right it engages with the gear, 6, on the reversing shaft, 63. The gear, 6, is attached to, or formed integrally with, the gear, 5, which meshes with the gear, 62, so that when the gear, 51, is engaged with the gear, 6, the shaft, 47, will be driven through the gears, 2, 60, 62, 5, 6, and 51, the introduction of the intermediate gears, 5 and 6, serving to reverse the direction of motion and giving direct control to the lowering of the drum, so that the control will not depend on the brake alone.

As already stated, slides 53 and 56, which control the movements of the gears 50 and 51, are operated by the lever 54. This lever is mounted on a shaft, 67, which revolves in bearings, 68. A hand-lever, 69, link, 70, and dog, 71, operating on an arc, 72, serve to retain the lever, 54, in any desired position. The shaft, 67, not only revolves in the bearings, 68, but is capable of a short longitudinal motion therein, by means of which by pushing the lever, 54, away from the operator as far as possible, it will engage with the notch, 57, while, by drawing it toward the operator it will engage with the notch, 55, thus giving control to all the movements of raising and lowering, by the one lever, 54. It will also be seen that by varying the ratios between the different gears, any desired ration of speed variation can be obtained, also that by changing the number of gears, more than three speeds of hoisting and one speed of lowering can be secured, if desired, and I do not desire to limit myself to any special construction, arrangement, or combination of gears, or auxiliary shafts, nor to any number of speeds of raising or lowering, as the device may be changed in all of these particulars without departing from my invention.

What I claim is:

1. In an apparatus of the character described, a motor, a drive shaft operatively connected thereto, a driven shaft, an auxiliary shaft and a reversing shaft, gearing carried by the respective shafts for changing the speed of and reversing the driven shaft, the drive and driven shafts being in substantial alinement and the auxiliary and reversing shafts extending substantially parallel with the drive and driven shafts, a hoisting drum, and a gear connection between the driven shaft and drum.

2. In an apparatus of the character described, a motor, a drive shaft adapted to be connected thereto, a driven shaft, an auxil-

iary shaft and a reversing shaft, gearing for the respective shafts for changing the speed of and reversing the driven shaft, the drive and driven shafts being in substantial alinement and the auxiliary and reversing shafts extending parallel with the drive and driven shafts, a second auxiliary shaft extending parallel to the drive shaft, a coupling between the second auxiliary shaft and driven shaft, a hoisting drum, a gear carried by the drum and the said second auxiliary shaft carrying a pinion adapted to mesh with the gear of the drum and a gear adapted to mesh with a pinion of the driven shaft.

3. In an apparatus of the character described, a motor, a drive shaft operatively connected thereto, a driven shaft, an auxiliary and a reversing shaft, gearing for the respective shafts for changing the speed of and reversing the driven shaft, the drive and driven shafts being in substantial alinement and the auxiliary and reversing shafts extending parallel with the drive and driven shafts, a second auxiliary shaft extending parallel to the drive shaft, a coupling between the second auxiliary shaft and driven shaft, a pinion on the driven shaft, a hoisting drum, a gear carried by the drum and the said second auxiliary shaft carrying a pinion adapted to mesh with the gear of the drum and a gear adapted to mesh with the pinion of the driven shaft, and a friction clutch between the motor and drive shaft.

4. In an apparatus of the character described, the combination of a motor having a drive shaft, speed changing gear mechanism having a drive shaft in substantial alinement with the shaft of the motor, clutch mechanism between the said shafts, a foot lever for operating said clutch, an auxiliary shaft arranged in substantial alinement with the driven shaft of the speed changing mechanism, a coupling between the driven shaft of the speed changing mechanism and the auxiliary shaft, a hoisting drum, and gearing interposed between the hoisting drum and the auxiliary shaft, substantially as and for the purpose described.

5. In an apparatus of the character described, the combination of a motor having a drive shaft, speed changing gear mechanism having a drive shaft in substantial alinement with the shaft of the motor, clutch mechanism between the said shafts, a foot lever for operating said clutch, an auxiliary shaft arranged in substantial alinement with the driven shaft of the speed changing mechanism, a coupling between the driven shaft of the speed changing mechanism and the auxiliary shaft, a gear mounted upon said drum, an elongated shaft extending longitudinally of the drum having a pinion at one end arranged to mesh with the gear of the drum and a gear at its

opposite end arranged to mesh with a pinion on said auxiliary shaft.

6. In an apparatus of the character described, the combination of a motor having a drive shaft, speed changing gear mechanism having a drive shaft in substantial alinement with the shaft of the motor, clutch mechanism between the said shafts, a foot lever for operating said clutch, an auxiliary shaft arranged in substantial alinement with the driven shaft of the speed changing mechanism, a coupling between the driven shaft of the speed changing mechanism and the auxiliary shaft, a gear mounted upon said drum, an elongated shaft extending longitudinally of the drum having a pinion at one end arranged to mesh with the gear of the drum and a gear at its opposite end arranged to mesh with a pinion on said auxiliary shaft, and peripheral guide grooves arranged adjacent opposite ends of the drum, a hand brake band engaging one of said grooves, and a power brake band engaging another of said grooves.

7. In an apparatus of the character described, a motor, a drive shaft operatively connected thereto, a driven shaft, an auxiliary shaft, and a reversing shaft, gearing carried by the respective shafts for changing the speed of and reversing the driven shaft, the drive and driven shafts being in substantial alinement and the auxiliary and reversing shaft extending substantially parallel with the drive and driven shafts, a hoisting drum, a gear connection between the driven shaft and drum, and an indicator associated with the gear connection for movement with the latter.

8. In an apparatus of the character de-

scribed, the combination of a motor having a drive shaft, speed changing gear mechanism having a drive shaft in substantial alinement with the shaft of the motor, clutch mechanism between the said shaft of the speed changing mechanism and the auxiliary shaft, a gear mounted upon said drum, an elongated shaft extending longitudinally of the drum having a pinion at one end arranged to mesh with the gear of the drum and a gear at its opposite end arranged to mesh with a pinion on said auxiliary shaft, a slidably mounted indicator, a worm for actuating the same and driven mechanism for the worm mounted on said elongated shaft.

9. In an apparatus of the character described, the combination of a hoisting drum, a supporting shaft therefor having bearings at its respective ends, braking mechanism mounted on the drum, a gear wheel mounted on the shaft of the drum between one end thereof and the adjacent bearing, an elongated shaft having bearing at its respective ends, said shaft being of a length to extend beyond the ends of the drum, a pinion at one end of said elongated shaft meshing with said gear, a gear wheel at the opposite end of the elongated shaft, a motor positioned below said elongated shaft, and gearing mechanism interposed between the motor and the gear of the elongated shaft for changing the speed ratio between the hoisting drum and motor.

In testimony whereof, I affix my signature in presence of two witnesses.

FREDERICK BAGLEY CLOSE.

Witnesses:

W. G. LANE,

W. C. THOMPSON.