

(19) World Intellectual Property Organization  
International Bureau



(43) International Publication Date  
23 July 2009 (23.07.2009)

PCT

(10) International Publication Number  
WO 2009/091836 A1

- (51) International Patent Classification:  
A61M 25/00 (2006.01) A61M 25/01 (2006.01)
- (21) International Application Number:  
PCT/US2009/031014
- (22) International Filing Date: 14 January 2009 (14.01.2009)
- (25) Filing Language: English
- (26) Publication Language: English
- (30) Priority Data:  
61/021,003 14 January 2008 (14.01.2008) US
- (71) Applicant (for all designated States except US): **BOSTON SCIENTIFIC SCIMED, INC.** [US/US]; One Scimed Place, Maple Grove, MN 55311-1566 (US).
- (72) Inventors: **GOLDEN, John**; 1 Furnace Pond Way, Norton, MA 02766 (US). **MCWEENEY, Sean**; 90 Academy Hill Road, #2, Brighton, MA 02135 (US). **CASTOLDI, Robert**; 356 Auburndale Avenue, Newton, MA 02466 (US).
- (74) Agent: **STALLMAN, Brandon, C.**; Christensen O'Connor Johnson Kindness PLLC, 1420 Fifth Avenue, Suite 2800, Seattle, WA 98101 (US).

- (81) Designated States (unless otherwise indicated, for every kind of national protection available): AE, AG, AL, AM, AO, AT, AU, AZ, BA, BB, BG, BH, BR, BW, BY, BZ, CA, CH, CN, CO, CR, CU, CZ, DE, DK, DM, DO, DZ, EC, EE, EG, ES, FI, GB, GD, GE, GH, GM, GT, HN, HR, HU, ID, IL, IN, IS, JP, KE, KG, KM, KN, KP, KR, KZ, LA, LC, LK, LR, LS, LT, LU, LY, MA, MD, ME, MG, MK, MN, MW, MX, MY, MZ, NA, NG, NI, NO, NZ, OM, PG, PH, PL, PT, RO, RS, RU, SC, SD, SE, SG, SK, SL, SM, ST, SV, SY, TJ, TM, TN, TR, TT, TZ, UA, UG, US, UZ, VC, VN, ZA, ZM, ZW.
- (84) Designated States (unless otherwise indicated, for every kind of regional protection available): ARIPO (BW, GH, GM, KE, LS, MW, MZ, NA, SD, SL, SZ, TZ, UG, ZM, ZW), Eurasian (AM, AZ, BY, KG, KZ, MD, RU, TJ, TM), European (AT, BE, BG, CH, CY, CZ, DE, DK, EE, ES, FI, FR, GB, GR, HR, HU, IE, IS, IT, LT, LU, LV, MC, MK, MT, NL, NO, PL, PT, RO, SE, SI, SK, TR), OAPI (BF, BJ, CF, CG, CI, CM, GA, GN, GQ, GW, ML, MR, NE, SN, TD, TG).

**Published:**

- with international search report
- before the expiration of the time limit for amending the claims and to be republished in the event of receipt of amendments

(54) Title: MEDICAL DEVICE

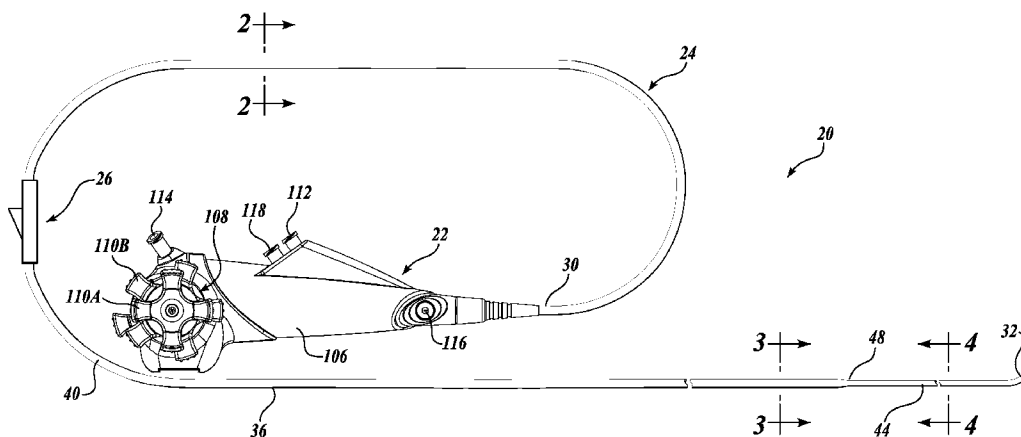


Fig. 1.

(57) **Abstract:** Apparatuses of the type broadly applicable to numerous medical applications in which it is desirable to insert one or more steerable or non-steerable catheters or similar devices into a working channel of an associated device, such as an endoscope, catheter, etc., or passageway of a patient, are disclosed. The apparatuses may include catheters (24) having a dedicated guide wire channel (60) and one or more of the following: viewing capabilities, a working channel, and auxiliary channels (62, 64, 66), such as insufflation/irrigation channels. The catheters may include a guide wire channel that is configured to provide the catheter or other device with rapid exchange capabilities.

WO 2009/091836 A1

## MEDICAL DEVICE

## CROSS-REFERENCE TO RELATED APPLICATION

This application claims the benefit of U.S. Provisional Application No. 5 61/021,003, filed January 14, 2008, the disclosure of which is hereby incorporated by reference.

## BACKGROUND

A challenge in the exploration and treatment of internal areas of the human anatomy has been adequately visualizing the area of concern. Visualization can be especially troublesome in minimally invasive procedures in which small diameter, 10 elongate instruments, such as catheters and endoscopes, are navigated through natural passageways of a patient to an area of concern either in the passageway or in an organ reachable through the passageway.

Detailed information regarding the anatomy can be discerned from direct viewing 15 of the anatomy provided through one or more of the elongate instruments used in the procedure. Various types of endoscopes configured for use in various passageways of the body such as the esophagus, rectum or bronchus can be equipped with direct viewing capability through the use of optical fibers extending through the length of the scope, or with digital sensors, such as CCD or CMOS. However, because endoscopes also provide 20 a working channel through which other medical instruments must pass, optional lighting bundles and components to provide steering capability at its distal end, the scope is typically of a relatively large diameter, e.g., 5 mm or greater. This large diameter limits the use of the endoscope to relatively large body channels and prohibits their use in smaller ducts and organs that branch from a large body channel, such as the biliary tree.

25 Typically, when examining small passageway such as the bile duct or pancreatic duct, the endoscope is used to get close to a smaller passageway or region of concern and another instrument, such as a catheter, is then extended through the working channel of the endoscope and into the smaller passageway. The catheter can be routed over a guide wire pre-placed in the area of interest. Alternatively, a catheter of the steerable type may 30 be steered into the smaller passageway with the aid of images provided from the endoscope, or if the steerable catheter has its own vision capabilities, steered into the smaller passageway with the aid of images provided by the catheter. One such steerable

catheter with vision capabilities is described in co-pending U.S. Application No. 11/089,520, filed March 23, 2005, which is hereby incorporated by reference. Once the catheter is in the small passage areas, visualization may be provided via contrast media and/or the vision capabilities of the catheter.

5           Visualization may reveal selected areas within the area of interest, such as the common bile duct, that require treatment. To treat the selected areas, a different catheter is sometimes required, necessitating a catheter exchange. A catheter exchange typically involves removing the first catheter from the endoscope over a guide wire pre-placed in the area of interest, and advancing a second catheter over the guide wire to the desired  
10 treatment site. In order to maintain a handle on the proximal end of the guide wire, it is necessary that the portion of the guide wire that remains outside the patient be longer than the length of the catheter. Therefore, a catheter/guide wire system suitable for these procedures has required the use of long guide wires that can be cumbersome to manipulate and can clutter an operating room.

15           To address the issues associated with changing catheters over long guide wires, many non-steerable catheters include so-called "rapid exchange" lumens or channels. These rapid exchange catheters typically include an opening on the sheath of a catheter and a slot that extends along the length of the catheter through which a guide wire can be pulled. To exchange the catheter for another device while maintaining the position of the  
20 guide wire in the body, the catheter is stripped off the guide wire by pulling it through the slot. A new catheter or device can then be routed over the guide wire by inserting the proximal end of the guide wire into an opening of a guide wire lumen at the distal end of the new device and advanced such that the proximal end of the guide wire exits the opening. The opening may be positioned towards the proximal end of the catheter or may  
25 be located more towards the distal end.

          While rapid exchange guide wire lumens have been developed for many procedures, they have not been adapted for use with steerable catheters, catheters with vision capabilities, catheters to be routed through the working channels of endoscopes, or catheters that are required to transmit torque from the proximal to the distal end of the  
30 catheter.

          In addition to performing a catheter exchange procedure, it may also be desirable to perform a guide wire exchange procedure. This may be desirable when, for example, a first guide wire is too large to fit through a desired body duct, or otherwise lacks the

desired characteristics. Under these circumstances, a physician may leave the catheter in place, withdraw the first guide wire from the catheter, and insert a second guide wire through the catheter to the desired site. During this procedure, the catheter guides the guide wire to the desired site. Thus, once the catheter is positioned at a target site, it is highly desirable to maintain the position of the catheter during a guide wire exchange procedure so that the second guide wire may be guided directly to the desired site in a minimum amount of time.

#### SUMMARY

This summary is provided to introduce a selection of concepts in a simplified form that are further described below in the Detailed Description. This summary is not intended to identify key features of the claimed subject matter, nor is it intended to be used as an aid in determining the scope of the claimed subject matter.

In accordance with aspects of the present invention, a catheter is provided which comprises an elongated shaft having a proximal end and a distal end, a guide wire channel extending along at least a portion of the shaft in-between the proximal and distal ends, at least one channel disposed within the shaft and extending to the distal end, and a guide wire opening disposed in communication with the guide wire channel of the shaft such that a guide wire may be insertable into the guide wire opening and routed into the guide wire channel. The shaft may be configured for providing radial access from a position exteriorly of the shaft to a portion of the guide wire channel that extends between the guide wire opening and a position proximal the distal end of the shaft in order to allow a guide wire to radially exit the shaft.

In accordance with another aspect of the present invention, a catheter is provided which comprises an elongated shaft having a proximal section and a distal section, a channel for accessing the distal end of the shaft, a guide wire channel extending along at least a portion of the shaft to the distal end of the shaft, and a guide wire port disposed at or near the transition between the proximal section and the distal section of the shaft. The guide wire port defines a guide wire port opening and a guide wire port conduit that communicate with the guide wire channel of the shaft such that a guide wire may be insertable into the guide wire port opening and routed into the guide wire channel. The catheter further comprises a deflector associated with the guide wire port and positionable in the guide wire conduit or the guide wire channel.

In accordance with another aspect of the present invention, a catheter is provided which comprises an elongated shaft having a proximal end and a distal end, a guide wire channel extending along at least a portion of the shaft in-between the proximal and distal ends, at least one optical channel disposed within the shaft and extending to the distal end, a guide wire opening disposed in communication with the guide wire channel of the shaft such that a guide wire may be insertable into the guide wire opening and routed into the guide wire channel, and means disposed along a portion of the shaft for allowing a guide wire to radially exit the shaft.

In accordance with another aspect of the present invention, a catheter is provided which comprises an elongated shaft having a proximal end and a distal end, wherein the elongated shaft comprises an core body an outer sleeve, and an inner reinforcement sheath disposed between the core body and the outer sleeve. The catheter further includes a guide wire channel extending along at least a portion of the shaft in-between the proximal and distal end, a guide wire opening disposed in communication with the guide wire channel of the shaft such that a guide wire may be insertable into the guide wire opening and routed into the guide wire channel, and means disposed along a section of the shaft for allowing a guide wire to radially exit the shaft, wherein the means is disposed outwardly of the inner reinforcement sheath for at least a first portion of the section of the shaft and disposed inwardly of the inner reinforcement sheath for at least a second portion of the section of the shaft.

In accordance with another aspect of the present invention, a catheter is provided which comprises an elongated shaft having a proximal end and a distal end. The shaft has a proximal section having a first diameter and a distal section having a second, smaller diameter. The catheter further includes a guide wire channel extending along a portion of the shaft in-between the proximal and distal end, at least two channels selected from the group consisting of a working channel, an optical channel, and a fluid channel, disposed within the shaft and extending to the distal end, and a guide wire opening disposed in communication with the guide wire channel of the shaft such that a guide wire may be insertable into the guide wire opening and routed into the guide wire channel, wherein the shaft includes a rapid exchange channel section along a portion thereof.

## DESCRIPTION OF THE DRAWINGS

The foregoing aspects and many of the attendant advantages of this invention will become more readily appreciated as the same become better understood by reference to the following detailed description, when taken in conjunction with the accompanying  
5 drawings, wherein:

FIGURE 1 is a plan view of an exemplary embodiment of a catheter assembly formed in accordance with aspects of the present invention;

FIGURE 2 is a cross-sectional view taken along line 2-2 in FIGURE 1;

FIGURE 3 is a cross-sectional view taken along line 3-3 in FIGURE 1;

10 FIGURE 4 is a cross-sectional view taken along line 4-4 in FIGURE 1;

FIGURE 5 is a perspective view of one exemplary embodiment of a guide wire port formed in accordance with aspects of the present invention;

FIGURE 6 is a cross-sectional view of the guide wire port of FIGURE 5;

15 FIGURE 7 is a plan view of an exemplary embodiment of a catheter formed in accordance with aspects of the present invention;

FIGURE 8 is a cross-sectional view taken along line 8-8 in FIGURE 7;

FIGURE 9 is a cross-sectional view taken along line 9-9 in FIGURE 7;

FIGURE 10 is a plan view of another exemplary embodiment of a catheter assembly formed in accordance with aspects of the present invention;

20 FIGURE 11 is an end view of a catheter of the catheter assembly shown in FIGURE 10, wherein a catheter of the catheter assembly is inserted into a working channel of an endoscope;

FIGURE 12 is a partial perspective view of the catheter shown in FIGURES 10 and 11;

25 FIGURE 13 is a partial side cross-sectional view of one exemplary embodiment of a guide wire port formed in accordance with aspects of the present invention;

FIGURE 14 is a plan view of another exemplary embodiment of a catheter assembly formed in accordance with aspects of the present invention;

FIGURE 15 is a cross-sectional view taken along line 15-15 in FIGURE 14;

30 FIGURE 16 is a cross-sectional view taken along line 16-16 in FIGURE 14;

FIGURE 17 is a partial perspective view of a taper or transition section formed in accordance with aspects of the present invention;

FIGURES 18A-18D are cross-sectional views of exemplary embodiments of the catheter; and

FIGURES 19A-19D are cross-sectional views of additional exemplary embodiments of the catheter.

5

#### DETAILED DESCRIPTION

Embodiments of the present invention will now be described with reference to the drawings where like numerals correspond to like elements. Embodiments of the present invention are directed to apparatuses of the type broadly applicable to numerous medical applications in which it is desirable to insert one or more steerable or non-steerable catheters or similar devices into a working channel of an associated device, such as an endoscope, catheter, etc., or passageway of a patient. Embodiments of the present invention are generally directed to features and aspects of a catheter having a dedicated guide wire channel and one or more of the following: viewing capabilities, a working channel, and auxiliary channels, such as insufflation/irrigation channels. In embodiments of the present invention, the guide wire channel may be configured to provide the catheter or other device with rapid exchange capabilities.

As will be described in detail below, the catheter may obtain viewing capabilities for viewing anatomical structures within the body by being constructed as a vision catheter or by having a fiberscope or other viewing device selectively routed through one of its channels. As such, embodiments of the present invention can be used for a variety of different diagnostic and interventional procedures. The catheter may be of the steerable type so that the distal end of the catheter may be steered from its proximal end as it is advanced within the body or of the non-steerable type. A suitable use for the catheters described herein includes, but is not limited to, diagnosis and/or treatment of the duodenum, and particularly the biliary tree.

Although exemplary embodiments of the present invention may be described hereinafter as suitable for use with duodenoscopes, it will be appreciated that embodiments of the present invention and aspects thereof have wide application, and may be suitable for use with other endoscopes (e.g., ureteroscopes) or medical devices, such as catheters (e.g., guide catheters, electrode catheters, angioplasty catheters, etc.). Accordingly, the following descriptions and illustrations herein should be considered illustrative in nature, and thus, not limiting the scope of the present invention.

30

Additionally, embodiments of the catheter may be utilized alone, as well as in conjunction with a conventional endoscope.

Referring now to FIGURE 1, there is shown a representative embodiment of a catheter assembly, generally designated 20, formed in accordance with aspects of the present invention. In the embodiment of FIGURE 1, the catheter assembly 20 includes a catheter handle 22, a catheter 24, and an optional guide wire port 26 positioned along a portion of the catheter 24. The catheter 24 includes a proximal end 30 that may be operatively connected to the catheter handle 22 and a distal end 32 that may be inserted into, for example, a working channel of an endoscope, such as a duodenoscope, or a passageway of a patient. The catheter 24 as shown includes a shaft 36 comprising a proximal section 40, a distal section 44, and an optional taper 48, which acts as a transition between the proximal section 40 and the distal section 44 of the catheter 24.

In the embodiment shown, the proximal section 40 has a larger cross-sectional area, e.g., diameter, than the distal section 44, although in other embodiments, the proximal section 40 and the distal section 44 may have the same generally uniform cross-sectional area. As such, the taper 48 may be omitted in these latter embodiments. The catheter 24 may further be of the steerable or deflectable type, and thus, the distal section 44 may either include an articulating section or may be constructed of a more flexible material than the proximal section 40 for aiding in the deflection of the distal end 32.

Referring now to FIGURES 2-4, one exemplary embodiment of the catheter shaft 36 is shown in more detail. FIGURES 2-4 are cross-sectional views of the proximal section 40 taken proximally and distally of the guide wire port 26 and of the distal section 44, respectively. As best shown in FIGURES 2-4, the catheter shaft 36 includes a dedicated guide wire channel 60 and one or more channels 62, 64, and 66 for providing access to a treatment area located at the distal end of the catheter.

In the embodiment shown in FIGURES 2-4, the dedicated guide wire channel 60 extends the entire length of the catheter through which a guide wire can be routed to and from the treatment area. In other embodiments, the guide wire channel 60 may not extend the entire length of the catheter shaft but instead extends only a portion thereof, for example, from one of many positions located distally of the proximal end to the catheter distal end. As will be described in more detail below, a portion of the catheter



shaft is slitted, slotted or otherwise configured to provide access along the catheter shaft 36 for providing rapid exchange capabilities to the catheter.

The one or more channels 62, 64, and 66 may extend from a position proximal of the distal end of the catheter shaft 36. For example, the one or more channels 62, 64, and 66 may extend to the distal end of the catheter shaft 36 from either the proximal end of the catheter or a position proximal of the catheter distal end.

As best shown in FIGURES 2-4, the one or more channels may include an optical channel 62. The optical channel 62 allows for the passage of a fiberscope, optical fiber cable, optical assembly, or other small diameter viewing catheter or device to the distal end of the catheter. In other embodiments, a fiberscope, optical fiber cable or the like may be permanently secured in place within the channel. Alternatively, the catheter 24 may be constructed as a video catheter, and as such, viewing capabilities are provided by an image sensor, such as a CCD, CMOS, or photo diode, mounted at or adjacent the distal end of the catheter 24. In this embodiment, the catheter may include other components, such as illumination sources, e.g., LEDs, etc., and associated power and signal transmission cabling, etc. It will be appreciated that in this embodiment, the optical channel may be used to provide a source of illumination to the distal tip by routing an illumination fiber therethrough, or such optical channel may be omitted.

The one or more channels may also include a working channel 64. The working channel 64 allows for the passage of various treatment or diagnostic devices, such as stone retrieval baskets, lasers, biopsy forceps, etc. to and from the treatment area located distally of the catheter distal end. The one or more channels may further include an additional channel 66 for use as an irrigation/insufflation channel, a fluid delivery channel, or multi-purpose channel. The channel 66 allows the passage of liquids, gases, and/or device to and from the treatment area.

As was described briefly above, in several embodiments of the present invention, the catheter 24 may be of a steerable-type, and thus, the catheter shaft 36 may optionally include one or more steering wire channels 70 that extend substantially the length of the catheter 24 for deflecting the distal end of the catheter shaft 36 in one or more directions. In the embodiment shown in FIGURES 2-4, steering wires 72 can be routed through a corresponding number of steering wire channels 70, extend from the distal end of the catheter to the opposing, proximal end of the catheter, and terminate in a suitable manner with a steering mechanism associated with the catheter handle 22, as will be described in

detail below. The steering wires 72 may be attached at anchor points to the distal section near or at the distal end of the catheter via conventional techniques, such as adhesive bonding, heat bonding, crimping, laser welding, resistance welding, soldering, etc., such that movement of the wires causes the distal end to deflect in a controllable manner. In one embodiment, the steering wires 72 are attached via welding or adhesive bonding to a fluoroscopy marker band (not shown) fixedly attached to the distal section. In this embodiment, the band may be held in place via adhesive and/or an outer sleeve.

The steering wires 72 preferably have sufficient tensile strength and modulus of elasticity that they do not deform (elongate) during curved deflection. In one embodiment, the steering wires are made from 304 stainless steel with an 0.008 inch diameter and have a tensile strength of approximately 325 KPSI. The steering wires 72 can optionally be housed in a PTFE thin-walled extrusion (not shown) to aid in lubricity and prevent the catheter 24 from binding up during deflections, if desired. For a more detailed description of types of steering wires and catheter shaft configurations that may be practiced with the present invention, please see co-pending U.S. Application No. 11/089,520, which is hereby incorporated by reference.

In the illustrated embodiment shown in FIGURES 2-4, the catheter 24 includes two pairs of steering wires 72 that controllably steer the catheter 24 in two substantially perpendicular planes. In alternative embodiments, the catheter 24 includes one pair of steering wires 72 that allow the user to steer the distal end in one plane. In a further embodiment, the catheter 24 only includes one steering wire 72 that allows the user to steer the distal end in one direction. In another embodiment, the steering wires may be omitted, and thus, the catheter 24 can be of a non-steerable type. In such an embodiment, the catheter can be advanced over a guide wire (not shown) pre-placed, for example, in the bile or pancreatic duct (referred in the art as "back loading" the catheter).

The dedicated guide wire channel 60, the one or more channels 62, 64, and 66, and the optional steering channels 70 may be separate tubular members, which are routed through a tubular catheter shaft. Alternatively, in the embodiment shown in FIGURES 2-4, the catheter shaft 36 may comprise a core body 80 that defines the dedicated guide wire channel 60, the one or more channels 62, 64, and 66, and the optional steering wire channels 70. In this embodiment, the core body 80 of the catheter shaft 36 may be constructed from any suitable material, such as Pebax® (polyether block amides), nylon, polytetrafluoroethylene (PTFE), polyethylene, polyurethane, fluorinated

ethylene propylene (FEP), thermoplastic elastomers and the like, or combinations or blends thereof. The core body 80 of the catheter shaft 36 may be formed as a one-piece design using known techniques in the art, such as extrusion, or may be formed in multiple segments, for example, multiple extruded sections, using one or more materials, which  
5 are then subsequently joined by heat bonding, adhesive bonding, lamination or other known techniques.

The embodiment of the catheter shaft 36 shown in FIGURES 2-4 may optionally include an outer sleeve 82. The outer sleeve 82 may extend the length of the catheter or sections thereof. The outer sleeve 82 may comprise one of any number of polymer  
10 jackets that are laminated, co-extruded, heat shrunk, adhesive bonded, or otherwise attached over the core body 80. Suitable materials for the sleeve 82 include, but are not limited to, polyethylene, nylon, Pebax® (polyether block amides), polyurethane, polytetrafluoroethylene (PTFE), and thermoplastic elastomers to name a few. The outer sleeve 82 may be used to vary the stiffness of the catheter, if desired, or to provide  
15 improved torque transfer and/or other desirable catheter properties. Additionally, the sleeve 82 may be used as one convenient method for securing a more flexible distal section 44 to the proximal section 40.

In several embodiments, the external surface of the sleeve 82 may have a hydrophilic coating or a silicon coating to ease the passage of the device in-vivo. Such a  
20 hydrophilic coating can be, for example, but not limited to, N-Vinyl Pyrrolidone, Poly Vinyl Alcohol, and Poly Vinyl Pyrrolidone. The hydrophilic coating can be accomplished by coating the device with a primer, such as Bayhydrol 110 (an anionic dispersion of an aliphatic polyester urethane resin in water/n-methyl-2pyrrolidone) and then bonding the primary layer over the primer. The primary layer can be, for example,  
25 but not limited to, an acrylamide or a polyurethane-based acrylamide. Aliphatic polyether and polyester polyurethanes also can be used as lubricous coatings.

In the embodiment shown in FIGURES 2-4, the outer sleeve 82 disposed on the proximal section 40 is thicker than the outer sleeve 82 disposed on the distal section for increasing the stiffness and torsional rigidity of the proximal section 40 of the catheter  
30 shaft 36. In another embodiment shown in FIGURES 7-9, the diameter of the core body 80 of the proximal section 40 is greater than the diameter of the core body 80 of the distal section 44 while the outer sleeve 82 is somewhat uniform in thickness as it extends from the beginning of the proximal section 40 to the end of the distal section 44. In this

embodiment, the larger core body of the proximal section increases the stiffness and/or torsional rigidity of the shaft.

In other embodiments, the catheter 24 may optionally include an inner reinforcement sheath 84 disposed between the core body 80 and the outer sleeve 82 along the distal section 44 (see FIGURE 1) of the catheter shaft 36 as shown in cross-section in FIGURE 4. The sheath 84 may be a woven or layered structure, such as a braided design of fine wire or polymeric elements (0.001 inches to 0.010 inches in diameter) woven or coiled together along the longitudinal axis of the catheter with conventional catheter braiding techniques. This allows the distal section of the catheter to be advanced to the desired anatomical site by increasing the column strength of the distal section while also increasing its torsional rigidity. Conventional coiled polymer or braid wire may also be used for this component with coil wire dimensioning ranging in width from 0.002 to 0.120 inches and thicknesses from 0.002 to 0.10 inches. Braided ribbon wire may also be used for the sheath. In one embodiment, the outer sleeve 82 is coextruded, coated, or otherwise attached, once the reinforcement layer 84 is applied to the distal section, to lock the reinforcement layer in place and secure it to the distal section core body 80. In one embodiment, the portion of the proximal section that extends from the proximal end to the beginning of the guide wire opening may also include a reinforcement sheath.

Turning now to FIGURES 5 and 6, the catheter shaft 36 may also include an opening 76 formed along a portion of the outer surface of the shaft 36 and positioned proximal the distal section 44. The opening 76 is formed so as to communicate with the guide wire channel 60 from a position external the shaft. Referring to FIGURE 1, the shaft opening (hidden by the guide wire port 26) may be positioned proximate or near the proximal end 30 of the catheter 24 or may be disposed further distally of the proximal end 30 along the catheter 24 toward the optional taper 48. Although it should be recognized that the shaft opening may be located at any location distally of the proximal end 30 of the catheter 24, in one embodiment the shaft opening is located approximately between 140 and 180 centimeters (cm) from the taper 48 and/or the beginning of the distal section 44. In this manner, the catheter 24 may be utilized with a 260 cm or similar guide wire, as will be described in detail below. As will be described in detail below, the shaft opening 76 (FIGURES 5 and 6) in one embodiment communicates with the guide wire port 26 for facilitating the insertion of a guide wire into the guide wire channel during use.

Returning to FIGURES 5 and 6, the catheter shaft 36 may further include a slit, a slot, or other means for allowing a guide wire to radially exit the guide wire channel 60 along a portion of the shaft 36, thereby providing rapid exchange capabilities to the catheter. In the illustrated embodiment of FIGURES 5 and 6, the catheter shaft 36 includes a slot 78 that connects the guide wire channel 60 to the exterior of the shaft for allowing a guide wire to radially exit the guide wire channel 60. The slot 78 extends from the shaft opening 76 to a position distally thereof, such as the beginning of the optional taper or catheter distal section. As best shown in the embodiment of FIGURE 3, the slot 78 is formed in the core body 80 and the optional outer sleeve 82 of the catheter shaft 36. In embodiments that do not include an outer sleeve, the slot 78 is formed in the core body. As such, the slot 78 and the guide wire channel 60 together define a slotted channel section. The slotted channel section may define, for example, a general U or C-shaped channel, although other slotted configurations may be practiced with the present invention, and are contemplated to be within the scope of the present invention, as claimed.

In use, the slotted channel section serves to contain, but not constrain, a guide wire as it is routed between the opening 76 and the beginning of the distal section 44. The guide wire channel 60 is sufficiently large to allow unhindered radial guide wire movement therein. In the embodiment of FIGURE 3, the slot 78 is sized to allow passage of a conventional guide wire (e.g., 0.025 inch-0.035 inch diameter guide wires) radially therethrough. In several embodiments, the slot 78 is substantially equal to or slightly larger than the diameter of the guide wire channel 60. In other embodiments, the slot 78 may be smaller than the diameter of the guide wire channel 60, as shown, for example, in FIGURE 3. In yet other embodiments, the slot may be smaller than the diameter of the guide wire routed therethrough, as shown in the example of FIGURE 15. In these embodiments, the slotted channel section is configured to allow separation at the opening to the guide wire channel to promote radial passage of the guide wire.

While the embodiments shown in FIGURES 3, 5, and 6 employ a slotted configuration for allowing a guide wire to radially exit the guide wire channel 60, other configurations are contemplated to be within the scope of the present invention, as claimed. For example, instead of a portion of the slot 78 being formed in the outer sleeve 82, the outer sleeve 82 may be formed with a slit with abutting edges, a flap with overlapping edges or interlocking edges, as shown in FIGURES 18A-18C, respectively.

Alternatively, as shown in FIGURE 18D, a layer of material of the outer sleeve disposed in-between the guide wire channel 60 and the exterior of the shaft may be relatively thin, weakened to promote tearing, perforated, or is composed of a generally soft material for providing a weak wall through which a guide wire can be pulled.

5           FIGURES 19A-19D illustrate other exemplary configurations for allowing a guide wire to radially exit the guide wire channel 60. In these examples, the outer sleeve has been omitted. As best shown in FIGURES 19A-19C, the catheter shaft 36 may be formed with a slit with abutting edges, a flap with overlapping edges or interlocking edges, respectively. Alternatively, as shown in FIGURE 19D, a layer of material  
10 disposed in-between the guide wire channel 60 and the exterior of the shaft may be relatively thin, weakened to promote tearing, perforated, or is a generally soft material for providing a weak wall through which a guide wire can be pulled. In this regard, these aforementioned sections, along with the slotted channel section described above, may be referred herein as rapid exchange channel sections of the catheter shaft.

15           Returning to FIGURE 1, the catheter assembly 20 may further include a guide wire port 26 positioned, for example, along a portion of the proximal section 40 of the catheter shaft 36. In use, the guide wire port 26 communicates with the shaft opening 76 (see FIGURES 5 and 6) for providing access to the guide wire channel. As such, the guide wire port 26 may be positioned proximate or near the proximal end 30 of the  
20 catheter 24 or may be disposed further distally of the proximal end 30 along the catheter 24 toward the optional taper 48, depending on the location of the shaft opening. Although it should be recognized that the guide wire port 26 may be located at any location distally of the proximal end 30 of the catheter 24, in one embodiment it is located approximately between 140 and 180 centimeters from the taper 48.

25           Referring now to FIGURES 5 and 6, one exemplary embodiment of the guide wire port 26 is shown in more detail. As best shown in the embodiments of FIGURES 5 and 6, the guide wire port 26 may include a main body 86 and a funnel-shaped extension 88. The funnel-shaped extension 88 is connected to and disposed adjacent the main body 86. The main body 86 includes a main channel 90 extending therethrough.  
30 The main channel 90 is sized to accommodate the catheter shaft 36 in a slidably restricting manner. Once positioned on the catheter shaft 36 in a suitable position, the guide wire port 26 is fixedly secured to the catheter shaft 36.

In the embodiment shown in FIGURES 5 and 6, the funnel-shaped extension 88 includes a funnel channel 92 having a proximal opening 94 and a distal opening 96. In several embodiments, the proximal opening 94 of the funnel channel 92 may be dimensioned significantly larger than the guide wire to be used with the catheter so that the guide wire may be easily inserted into the funnel channel 92. The distal opening 96 of the funnel channel 92 is positioned and sized to communicate with the guide wire channel 60 of the catheter shaft 36, as will be described in more detail below, so that the guide wire may be inserted into the funnel channel 92 through the proximal opening 94 and into the guide wire channel 60 through the distal opening 96. The distal end of the main body 86 and the distal portion of the funnel-shaped extension 88 converge together to define a merged section 100. The main channel 90 and the funnel channel 92 also merge together into a merged channel 102 in the merged section 100. The funnel-shaped extension 88 further includes a slot or slit 104 for providing access to the funnel channel 92. The slot 104 extends along the length of the funnel-shaped extension 88 and the distal merged section 100. The slot 104 is sized to allow passage of a conventional guide wire therethrough.

When assembled, the slot 104 of the guide wire port 26 is substantially aligned with the slot 78, the slit, or other means for allowing a guide wire to radially exit the guide wire channel 60, as shown in the embodiment of FIGURES 5 and 6. Additionally, the shaft opening 76 is aligned with and is dimensioned to correspond to the distal opening 96 of the tunnel channel 92 for communication therebetween. As such, the rapid exchange channel section and the guide wire port 26 allows rapid exchange of either the guide wire or of the catheter 24 when an alternative catheter or guide wire is desired during certain medical procedures. Additionally, shorter length guide wires, such as 260 centimeter guide wires, may be used since the guide wire does not need to pass through the proximal end of the catheter shaft 36. Alternatively, it will be appreciated that such a catheter shaft construction as shown and described herein also allows for longer length guide wires, such as the conventional 450 centimeter guide wires, to be routed from the proximal end 30 of the catheter shaft 36 to the distal end 32 of the catheter shaft 36, and beyond.

In exemplary embodiments of the present invention, the catheter shaft 36 may have one or more of the following dimensions. For example, the proximal section 40 may be approximately 200-240 centimeters in length and have an outside diameter of

approximately 12 French. In this embodiment, the outer diameter of the core body 80 is approximately 0.125 inches. The core body 80 may house a working channel 60 having a diameter of approximately 0.054 inches, an optical channel 62 having a diameter of approximately 0.044 inches, an irrigation channel 66 having a diameter of approximately 0.032 inches, a guide wire channel 64 having a diameter of approximately 0.040 inches (for use with a 0.035 inch diameter guide wire), and four steering wire channels 70 each having a diameter of approximately 0.012 inches. The core body 80 may be sheathed with an outer sleeve 82 having a thickness of approximately 0.006-0.012 inches. Alternatively, the core body can remain unsheathed and have an outer diameter of approximately 11-12 French. It will be appreciated that the aforementioned dimensions may have tolerances of approximately 0.002 inches.

The distal section 44 may be approximately 10-40 centimeters in length and have an outside diameter of approximately 11 French. In this embodiment, the outer diameter of the core body 80 is approximately 0.125 inches. The dimensions of the aforementioned channels are substantially identical. The core body 80 may be sheathed with a reinforcement layer 84 and an outer sleeve 82. The reinforcement layer 84 has a thickness of approximately 0.0035 inches and the outer sleeve 82 has a thickness of approximately 0.006 inches. Alternatively, the distal section of the core body can omit the reinforcement layer and outer sleeve, and have an outer diameter of approximately 10-11 French. It will be appreciated that the aforementioned dimensions may have tolerances of approximately 0.002 inches.

In other embodiments, such as those illustrated in FIGURES 7-9, the outside diameter of the proximal section core body 80 may be approximately 0.145 inches or around 11 French. The core body 80 of the proximal section 40 in this embodiment may also be encased with an outer sleeve 82 of approximately 0.006 inch thickness, resulting in an outer diameter of the shaft of approximately 12 French. In this embodiment, the outer diameter of the core body 80 of the distal section 44 is approximately 0.125 inches, and may include a reinforcement layer (not shown) of approximately 0.0035 inch thickness and/or an outer sleeve 82 of approximately 0.006 inch thickness. Alternatively, the proximal section of the core body can remain unsheathed and have an outer diameter of approximately 12 French, and the distal section of the core body can remain unsheathed and unreinforced and have an outer diameter of approximately 11 French.



In yet other embodiments, the catheter may be used with an 0.025 inch diameter guide wire. As such, the diameters of the internal channels may be adjusted so that the overall outer diameter of the catheter is reduced. For example, in this embodiment, the outer diameter of the core body 80 may be approximately 0.115 inches. The core body 80 may house a working channel 60 having a diameter of approximately 0.054 inches, an optical channel 62 having a diameter of approximately 0.040 inches, an irrigation channel 66 having a diameter of approximately 0.030 inches, a guide wire channel 64 having a diameter of approximately 0.030 inches, and four steering wire channels 70 each having a diameter of approximately 0.012 inches. The core body 80 may be sheathed with an outer sleeve 82 having a thickness of approximately 0.050 inches. Accordingly, the outside diameter of the catheter is approximately 0.125 inches, or slightly less than 10 French. It will be appreciated that the aforementioned dimensions may have tolerances of approximately 0.002 inches. It will further be appreciated that in this embodiment, the outer sleeve 82 may have a thickness of approximately 0.010-0.012 inches on the proximal section to increase stiffness, etc, resulting in a proximal section having an outer diameter of approximately 11 French.

Returning to the embodiment of FIGURE 1, the catheter 24 may be functionally connected to the catheter handle 22. FIGURE 1 illustrates one exemplary embodiment of a catheter handle that may be practiced with embodiments of the catheter 24, although many others may be alternatively used. As best shown in FIGURE 1, the handle 22 includes a handle housing 106 to which a steering mechanism 108, one or more ports, and an optional endoscope attachment device (not shown) is operatively connected. The one or more ports may include any combination of a working channel port 112 for providing access to the working channel from the proximal end of the catheter 24, an optical channel port 114 for providing access to the optical channel from the proximal end of the catheter 24, and a fluid channel port 116 for providing access to the irrigation/insufflation channel from the proximal end of the catheter 24. The catheter handle 22 may include an optional guide wire port 118 for providing access to the guide wire channel from the proximal end of the catheter 24.

While the ports 112, 114, and 116 are shown on the handle 22, it will be appreciated that ports for accessing the one or more channels of the catheter shaft may additionally or alternatively be disposed anywhere along the catheter shaft, preferably somewhere along the proximal section.

The steering mechanism 108 of the catheter handle 22 controls deflection of the distal end 32 of the catheter 24. The steering mechanism 108 may be any known or future developed mechanism that is capable of deflecting the distal end of the catheter by selectively pulling the steering wires. In the embodiment shown in FIGURE 1, the steering mechanism 108 includes two rotatable knobs for effecting 4-way steering of the catheter distal end in the up/down direction and in the right/left direction. This mechanism 108 includes an outer knob 110A to control up/down steering and an inner knob 110B to control right/left steering. Alternatively, the inner knob 110B may function to control right/left steering and an outer knob 110A may function to control up/down steering. The knobs interface with the distal end 32 of the catheter 30 via the steering wires 72 (See FIGURE 4) that extend through the catheter 24.

While a manually actuated steering mechanism for effecting 4-way steering of the distal is shown, it will be appreciated that a manually actuated steering mechanism that effects 2-way steering may be practiced with and is therefore considered to be within the scope of the present invention. Please see co-pending U.S. Application No. 11/089,520, which is hereby incorporated by reference, for a more detailed description of steering mechanisms that may be practiced with the present invention. In embodiments of the catheter handle that connect to non-steerable catheters, it will be appreciated that the steering mechanism may be omitted from the handle.

In use, various treatment or diagnostic devices, such as stone retrieval baskets, lasers, biopsy forceps, etc. may be inserted into the working channel port 112 of the catheter handle 22 and routed to the treatment area located distally of the catheter distal end. Optical devices, such as vision catheters or fiberscopes, may be inserted into the optical channel port 114 of the catheter handle 22 and routed to the treatment area located distally of the catheter distal end. Fluids, such as liquids or gases, may be injected into the fluid port 116 and delivered to the distal end of the catheter. Finally, a guide wire may be inserted into the optional guide wire port or working channel port if desired, and routed to the treatment area located distally of the catheter distal end.

For examples of imaging devices that may be practiced with embodiments of the present invention, please see the description of the fiber optic cable in co-pending U.S. Application No. 10/914,411, filed August 9, 2004, the fiberscope and methods of use in co-pending U.S. Application No. 11/089,520, and the guide wire scope described in

U.S. Published Patent Application Number 2004/0034311 A1, the disclosures of which are hereby incorporated by reference.

Turning now to FIGURES 10-13, there is shown another representative embodiment of a catheter assembly, generally designated 120. The catheter assembly 120 is substantially identical in construction, materials, and operation as the catheter assembly 20, except for the differences that will now be described. As best shown in FIGURE 10, the catheter assembly 120 may include a catheter handle 22, a catheter 124, and a guide wire port 126 positioned along a portion of the catheter 124. The catheter 124 includes a proximal end 130 that may be operatively connected to the catheter handle 22 and a distal end 132 that may be inserted into, for example, a working channel of an endoscope or a passageway of a patient.

The catheter 124 includes a shaft 136 having a generally cylindrically-shaped body of substantially uniform diameter. The shaft 136 comprises a proximal section 140 and a distal section 144. In several embodiments, the distal section 144 or portions thereof may be constructed to be more flexible or bendable so that the distal end 132 of the catheter shaft 136 may be steered in one or more directions during use.

Turning now to FIGURE 11, there is shown an end view of the catheter shaft 136 positioned within a working channel WC of an endoscope. Substantially similar to the catheter shaft 36 of FIGURES 2-4, the catheter shaft 136 may define an optical channel 162 and a working channel 164 that extend the length of the catheter from its proximal end 130 to its distal end 132. The shaft 136 also includes a dedicated guide wire channel 160 that extends the entire length of the catheter 124 through which a guide wire can be routed to and from the treatment area. However, in contrast to the catheter shaft 36 shown in FIGURE 3 and described above, the rapid exchange section of the catheter shaft 36 is omitted. The shaft 136 may further include an additional channel 166 that extends the entire length of the catheter shaft 136 for use as an irrigation/insufflations channel or fluid delivery channel.

In one embodiment, the catheter shaft may be constructed of a core body 180, an outer sleeve 182, and an inner reinforcement sheath 184. The inner reinforcement sheath 184 is disposed in-between the core body 180 and the outer sleeve 182, as best shown in FIGURE 12, and functions to provide increased column strength and torsional rigidity. The inner reinforcement sheath 184 and outer sleeve 182 extend along the catheter shaft 136 from the proximal end 130 to the distal end 132, or portions thereof.

Finally, the catheter shaft may include an opening 176 formed along a portion of the outer surface of the shaft and positioned, for example, near or at the beginning of the distal section, as best shown in FIGURE 13. The opening 176 is formed so as to communicate with and provide access to the guide wire channel 164 from a position that is external to the shaft. As such, the opening 176 in the embodiment shown is formed through the outer sleeve 182, the reinforcement sheath 184 (not shown in FIGURE 13 for ease of illustration), and a portion of the core body 180. As will be described in detail below, the opening 176 communicates with the guide wire port 126 for facilitating the insertion of a guide wire into the guide wire channel during use.

Returning to FIGURE 10, the catheter 124 further includes a guide wire port 126 positioned near or at the beginning of the distal section 144 for providing access to a guide wire channel of the catheter shaft 136. In one embodiment, the guide wire port is located approximately between 5 and 30 centimeters from the distal end of the catheter shaft. In that regard, shorter guide wires, such as those approximately 260 cm to 450 cm, may be employed by the catheter 124. Referring now to FIGURE 13, the guide wire port 126 is shown in more detail. As best shown in FIGURE 13, the guide wire port 126 includes an extension section 188 and an optional deflector 198. The extension section 188 is disposed adjacent the catheter shaft 136. In several embodiments of the present invention, the guide wire port 126 can be constructed as a section of the outer sleeve 182.

The extension 188 includes a channel 192 having a proximal opening 194 and a distal opening 196. The proximal opening 194 of the channel 192 is preferably larger than the distal opening 196 to form a somewhat funnel-like channel. It will be appreciated that the proximal opening 194 of the guide wire port 126 is constructed as large as possible so that the guide wire GW may be easily inserted into the channel while also allowing the catheter shaft 136 to be inserted into a standard 4.2 mm inside diameter endoscope working channel WC as best shown in FIGURE 11. The distal opening 196 of the channel 192 is positioned and sized to communicate with the shaft opening 176, and in turn, the guide wire channel 164 of the catheter shaft 136 so that the guide wire GW may be inserted into the guide wire channel 164 through the distal opening 196 and shaft opening 176.

The guide wire port 126 may be further formed with an optional deflector 198. In one embodiment, the deflector 198 is positioned to inwardly extend into the shaft

opening 176 and a substantial portion of the guide wire channel 160. The deflector 198 is operable to pivot about area 200 so as to either be capable of blocking access to the guide wire channel 164 of the catheter shaft 136 or the guide wire port channel 192. In several embodiments, the deflector 198 is inwardly biased to the position shown in FIGURE 13.

5 In this position, a guide wire may be front loaded into either the optional guide wire port 118 on the catheter handle 22 (see FIGURE 10) and routed through the catheter shaft to the distal end of the catheter or inserted into the guide wire port proximal opening 194 and routed to the distal end of the catheter. It will be appreciated that in this embodiment, if routed down the guide wire port on the handle, the guide wire would temporarily  
10 displace the deflector so that the guide wire could pass through.

Once the guide wire is removed, the deflector 198 is again biased to the position in FIGURE 13. In this manner, the catheter is also back loadable. For example, when the catheter is routed over a guide wire previously placed within a body channel, the guide wire enters the distal end opening 196 of the guide wire channel 192 and then is routed  
15 through the guide wire port channel 192 as a result of the deflector 198. It will also be appreciated that the deflector 198 could be biased in a position that blocks the distal opening 196 of the guide wire port channel 192 so that the back loadable guide wire is routed through the guide wire channel 160 to the catheter's proximal end and out of the optional guide wire port of the catheter handle.

20 In exemplary embodiments of the present invention, the catheter 124 may have one or more of the following dimensions. For example, the proximal section 140 may be approximately 200-240 centimeters in length and have an outside diameter of approximately 10 French. The distal section 144 may be approximately 10-40 centimeters in length and have an outside diameter of approximately 10 French. In this  
25 embodiment, the outer diameter of the core body 180 is approximately 0.118 inches. The core body 180 may house a working channel 160 having a diameter of approximately 0.050 inches, an optical channel 162 having a diameter of approximately 0.042 inches, an irrigation channel 166 having a diameter of approximately 0.030 inches, a guide wire channel 164 having a diameter of approximately 0.040 inches (for use with a 0.035 inch  
30 diameter guide wire), and four steering wire channels 170 each having a diameter of approximately 0.012 inches. The core body 180 may be sheathed with a reinforcement layer 184 and an outer sleeve 182. For example, a reinforcement layer 184 may be employed having a thickness of approximately 0.0035 inches and the outer sleeve 182

may be employed having a thickness of approximately 0.0035 inches. It will be appreciated that the aforementioned dimensions may have tolerances of approximately 0.002 inches.

Turning now to FIGURES 14-17, there is shown another representative embodiment of a catheter assembly, generally designated 220. The catheter assembly 220 is substantially identical in construction, materials, and operation as the catheter assembly 20, except for the differences that will now be described. The catheter assembly 220 may include a catheter handle 22, a catheter 224, and a guide wire port 226 positioned along a portion of the proximal section of catheter 224. The catheter 224 includes a proximal end 230 that may be operatively connected to the catheter handle 22 and a distal end 232 that may be inserted into, for example, a working channel of an endoscope or a passageway of a patient. The catheter 224 includes a shaft 236 comprising a proximal section 240, a distal section 244, and a taper 248, which acts as a transition between the proximal section 240 and the distal section 244 of the catheter 224. In several embodiments, the distal section 244 or portions thereof may be constructed to be more flexible or bendable so that the distal end 232 of the catheter shaft 236 may be steered in one or more directions during use.

Turning now to FIGURES 15 and 16, there are shown cross-sectional views of the proximal section 240 taken distally of the guide wire port 126 and the distal section 144, respectively. Substantially similar to the catheter shaft 36 of FIGURE 3, the catheter shaft 236 may include an optical channel 262 and a working channel 264 that extend the length of the catheter or portions thereof. The shaft 236 may also include an additional channel 266 for use as an irrigation/insufflations channel or fluid delivery channel. The shaft 236 further includes a dedicated guide wire channel 260 that extends the entire length of the catheter through which a guide wire can be routed to and from the treatment area. The guide wire channel 260 includes a slot 278 from the guide wire port 226 to the beginning of the taper of the catheter shaft 236 as shown in FIGURE 16. As described in more detail above, other means for accessing the guide wire channel may be employed, including those shown in FIGURES 18 and 19.

As best shown in FIGURES 15 and 16, the shaft may be constructed of a core body 280, an outer sleeve 382, and an inner reinforcement sheath 284 disposed in-between the core body 280 and the outer sleeve 282 for providing improved column strength and torsional rigidity. The inner reinforcement sheath 284 and outer sleeve 282

extend along the catheter shaft from the proximal end to the distal end, or portions thereof. The outer sleeve 282 in this embodiment forms the slotted channel section as it extends from the guide wire port 226 to the taper 248. At the taper 248, the slot 278 of the guide wire channel 260 terminates and the guide wire channel 260 merges gradually  
5 into the core body 280 of the catheter shaft, as best shown in FIGURE 17. It will be appreciated that in this portion of the catheter shaft, the reinforcement sheath 284 is omitted or an aperture is created so that the guide wire channel 260 can transition from being disposed outside of the core body 280, as best shown in FIGURE 15, to being disposed inside the core body 280, as shown best in FIGURE 16.

10 In exemplary embodiments of the present invention, the catheter 224 may have one or more of the following dimensions. For example, the proximal section 240 may be approximately 200-240 centimeters in length and have an outside width of approximately 0.147-0.155 inches and a height of approximately 0.132-0.135. The distal section 244 may be approximately 10-40 centimeters in length and have an outside diameter of  
15 approximately 10-11 French. The core body 280 may house a working channel 260 having a diameter of approximately 0.054 inches, an optical channel 262 having a diameter of approximately 0.044 inches, an irrigation channel 166 having a diameter of approximately 0.030 inches, a guide wire channel 164 having a diameter of approximately 0.030-0.040 inches (depending on use of a 0.025 or 0.035 inch diameter  
20 guide wire), and four steering wire channels 170 each having a diameter of approximately 0.012 inches. The core body 180 may be sheathed with a reinforcement layer 184 and an outer sleeve 182. In these embodiments, the reinforcement layer 284 has a thickness of approximately 0.0035 inches and the outer sleeve 282 has a thickness of approximately 0.0035 inches. It will be appreciated that the aforementioned dimensions may have  
25 tolerances of approximately 0.002 inches.

The principles, representative embodiments, and modes of operation of the present invention have been described in the foregoing description. However, aspects of the present invention which are intended to be protected are not to be construed as limited to the particular embodiments disclosed. Further, the embodiments described herein are  
30 to be regarded as illustrative rather than restrictive. It will be appreciated that variations and changes may be made by others, and equivalents employed, without departing from the spirit of the present invention. Accordingly, it is expressly intended that all such

variations, changes, and equivalents fall within the spirit and scope of the present invention, as claimed.



## CLAIMS

The embodiments of the invention in which an exclusive property or privilege is claimed are defined as follows:

1. A catheter, comprising:
  - an elongated shaft having a proximal end and a distal end;
  - a guide wire channel extending along at least a portion of the shaft in-between the proximal and distal ends;
  - at least one channel disposed within the shaft and extending to the distal end;
  - a guide wire opening disposed in communication with the guide wire channel of the shaft such that a guide wire may be insertable into the guide wire opening and routed into the guide wire channel; andwherein the shaft is configured for providing radial access from a position exteriorly of the shaft to a portion of the guide wire channel that extends between the guide wire opening and a position proximal the distal end of the shaft in order to allow a guide wire to radially exit the shaft.
2. The catheter of Claim 1, wherein the at least one channel is selected from the group consisting of an optical channel, a working channel, an accessory channel, a fluid channel, and combinations thereof.
3. The catheter of Claim 1, further comprising at least one steering wire for deflecting the distal end of the shaft.
4. The catheter of Claim 1, wherein the shaft includes a slot for allowing the guide wire to radially exit the shaft, and wherein the slot and guide wire channel define a slotted channel section between said positions.
5. The catheter of Claim 4, wherein the shaft includes a core body and an outer sleeve, and wherein the slotted guide wire section terminates as the guide wire channel transitions from being disposed outside of the core body to being disposed inside of the core body.
6. The catheter of Claim 1, wherein the shaft includes means disposed along a portion of the shaft for allowing a guide wire to radially exit the shaft.

7. The catheter of Claim 1, wherein the shaft includes a proximal section and a distal section.

8. The catheter of Claim 7, wherein the shaft further includes a taper disposed between the proximal and distal sections.

9. The catheter of Claim 8, wherein the guide wire opening is disposed in the proximal section of the shaft.

10. The catheter of Claim 7, wherein the shaft includes a core body and an outer sleeve, and wherein the diameter of the core body along a portion of the proximal section is greater than the diameter of the core body along a portion of the distal section.

11. The catheter of Claim 7, wherein the shaft includes a core body and an outer sleeve, and wherein the outer sleeve along the proximal section is thicker than the outer sleeve along the distal section.

12. The catheter of Claim 7, wherein the outer diameter of the proximal section is approximately 11-12 French and the outer diameter of the distal section is between approximately 10-11 French.

13. The catheter of Claim 12, wherein the outer diameter of the proximal section is approximately 11 French and the outer diameter of the distal section is approximately 10 French.

14. The catheter of Claim 7, wherein the outer diameter of the proximal section of the shaft and the distal section of the shaft is approximately 11 French.

15. The catheter of Claim 1, wherein the guide wire opening is disposed between approximately 100 and 180 centimeters from the distal end of the shaft.

16. The catheter of Claim 1 wherein the cross-section of the shaft is such that the catheter is capable of being inserted into a working channel of an endoscope.

17. The catheter of Claim 7, wherein the proximal section is approximately 200-240 centimeters in length and the distal section is between approximately

10-40 centimeters in length and the shaft has a total length of no more than approximately 260 centimeters.

18. A catheter, comprising:

an elongated shaft having a proximal section and a distal section;

a channel for accessing the distal end of the shaft;

a guide wire channel extending along at least a portion of the shaft to the distal end of the shaft;

a guide wire port disposed at or near the transition between the proximal section and the distal section of the shaft, the guide wire port defining a guide wire port opening and a guide wire port conduit that communicate with the guide wire channel of the shaft such that a guide wire may be insertable into the guide wire port opening and routed into the guide wire channel; and

a deflector associated with the guide wire port and positionable in the guide wire conduit or the guide wire channel.

19. The catheter of Claim 18, wherein the deflector is biased inwardly to substantially block access to the guide wire channel.

20. The catheter of Claim 18, wherein the outer diameter of the proximal section of the shaft and the distal section of the shaft is approximately 10 French.

21. The catheter of Claim 18, wherein the catheter is front loadable and/or back loadable in use.

22. The catheter of Claim 18, wherein the guide wire port is located approximately between 10-50 cm from the distal end of the shaft.

23. A catheter, comprising:

an elongated shaft having a proximal end and a distal end;

a guide wire channel extending along at least a portion of the shaft in-between the proximal and distal ends;

at least one optical channel disposed within the shaft and extending to the distal end;

a guide wire opening disposed in communication with the guide wire channel of the shaft such that a guide wire may be insertable into the guide wire opening and routed into the guide wire channel; and

means disposed along a portion of the shaft for allowing a guide wire to radially exit the shaft.

24. A catheter, comprising:

an elongated shaft having a proximal end and a distal end, the elongated shaft comprised of a core body, an outer sleeve, and an inner reinforcement sheath disposed between the core body and the outer sleeve;

a guide wire channel extending along at least a portion of the shaft in-between the proximal and distal end;

a guide wire opening disposed in communication with the guide wire channel of the shaft such that a guide wire may be insertable into the guide wire opening and routed into the guide wire channel; and

means disposed along a section of the shaft for allowing a guide wire to radially exit the shaft, wherein the means is disposed outwardly of the inner reinforcement sheath for at least a first portion of the section of the shaft and disposed inwardly of the inner reinforcement sheath for at least a second portion of the section of the shaft.

25. A catheter, comprising:

an elongated shaft having a proximal end and a distal end, the shaft having a proximal section having a first diameter and a distal section having a second, smaller diameter;

a guide wire channel extending along a portion of the shaft in-between the proximal and distal end;

at least two channels selected from the group consisting of a working channel, an optical channel, and a fluid channel, disposed within the shaft and extending to the distal end;

a guide wire opening disposed in communication with the guide wire channel of the shaft such that a guide wire may be insertable into the guide wire opening and routed into the guide wire channel; and

wherein the shaft includes a rapid exchange channel section along a portion thereof.

26. A catheter, comprising:

an elongated shaft having a proximal end and a distal end, the shaft capable of being routed through a working channel of an endoscope;

at least one steering wire channel;

a guide wire channel extending along at least a portion of the shaft in-between the proximal and distal end;

an optical channel disposed within the shaft and extending to the distal end;

a guide wire opening disposed in communication with the guide wire channel of the shaft such that a guide wire may be insertable into the guide wire opening and routed into the guide wire channel; and

wherein the shaft is configured for providing radial access from a position exteriorly of the shaft to a portion of the guide wire channel that extends between the guide wire port and a position proximal the distal end of the shaft in order to allow a guide wire to radially exit the shaft.

27. A catheter, comprising:

an elongated shaft having a proximal end and a distal end, the shaft capable of being routed through a working channel of an endoscope;

at least one steering wire channel;

a guide wire channel extending along at least a portion of the shaft in-between the proximal and distal ends;

an optical channel disposed within the shaft and extending to the distal end;

a guide wire opening disposed in communication with the guide wire channel of the shaft such that a guide wire may be insertable into the guide wire opening and routed into the guide wire channel; and

wherein the shaft includes a slot that communicates with the guide wire channel, the slot extending between the guide wire opening and a position proximal the distal end of the shaft such that the guide wire channel defines a slotted channel section between said positions in order to allow a guide wire to radially exit the shaft.

28. The catheter of Claim 23, 24, 26, or 27, wherein the shaft includes a proximal section and a distal section.

29. The catheter of Claim 28, wherein the shaft further includes a taper disposed between the proximal and distal sections.

30. The catheter of Claim 28, wherein the guide wire opening is disposed in the proximal section of the shaft.

31. The catheter of Claim 23, 25, 26, or 27, wherein the shaft includes a core body and an outer sleeve.

32. The catheter of Claim 27, wherein the shaft includes a core body and an outer sleeve, and wherein the slotted guide wire section terminates as the guide wire channel transitions from being disposed outside of the core body to being disposed inside of the core body.

33. The catheter of Claim 23, 25, 26, or 27, wherein the shaft includes a core body and an outer sleeve, and wherein the diameter of the core body along a portion of the proximal section is greater than the diameter of the core body along a portion of the distal section.

34. The catheter of Claim 23, 25, 26, or 27, wherein the shaft includes a core body and an outer sleeve, and wherein the outer sleeve along the proximal section is thicker than the outer sleeve along the distal section.

35. The catheter of Claim 25, wherein the outer diameter of the proximal section is approximately 11-12 French and the outer diameter of the distal section is between approximately 10-11 French.

36. The catheter of Claim 28, wherein the outer diameter of the proximal section is approximately 11-12 French and the outer diameter of the distal section is between approximately 10-11 French.

37. The catheter of Claim 25, wherein the outer diameter of the proximal section is approximately 11 French and the outer diameter of the distal section is between approximately 10 French.

38. The catheter of Claim 28, wherein the outer diameter of the proximal section is approximately 11 French and the outer diameter of the distal section is between approximately 10 French.

39. The catheter of Claim 25, wherein the outer diameter of the proximal section of the shaft and the distal section of the shaft is approximately 11 French.

40. The catheter of Claim 28, wherein the outer diameter of the proximal section of the shaft and the distal section of the shaft is approximately 11 French.

41. The catheter of Claim 23, 24, 25, 26, or 27, wherein the guide wire opening is disposed between approximately 100 and 180 centimeters from the distal end of the shaft.

42. The catheter of Claim 23, 24, or 25, wherein the cross-section of the shaft is such that the catheter is capable of being inserted into a working channel of an endoscope.

43. The catheter of Claim 23, 24, 25, 26, or 27, further comprising at least one of a working channel and a fluid channel.

44. The catheter of Claim 25, wherein the proximal section is approximately 200-240 centimeters in length and the distal section is between approximately 10-40 centimeters in length and the shaft has a total length of no more than approximately 260 centimeters.

45. The catheter of Claim 28, wherein the proximal section is approximately 200-240 centimeters in length and the distal section is between approximately 10-40 centimeters in length and the shaft has a total length of no more than approximately 260 centimeters.

46. The catheter of Claim 1, 23, 24, 25, or 26, wherein the shaft includes a slit or a slot for allowing a guide wire to radially exit the shaft.

47. The catheter of Claim 23 or 24, further comprising at least one steering channel, and at least one steering wire disposed within the at least one steering channel.

48. A catheter, comprising:

an elongated shaft including a proximal section having a first cross-sectional area and a distal section having a second, smaller cross-sectional area;

a plurality of channels disposed within the shaft and extending from the proximal section to the distal section, wherein the plurality of channels includes a guide wire channel, a working channel, a fluid channel, and an optical channel;

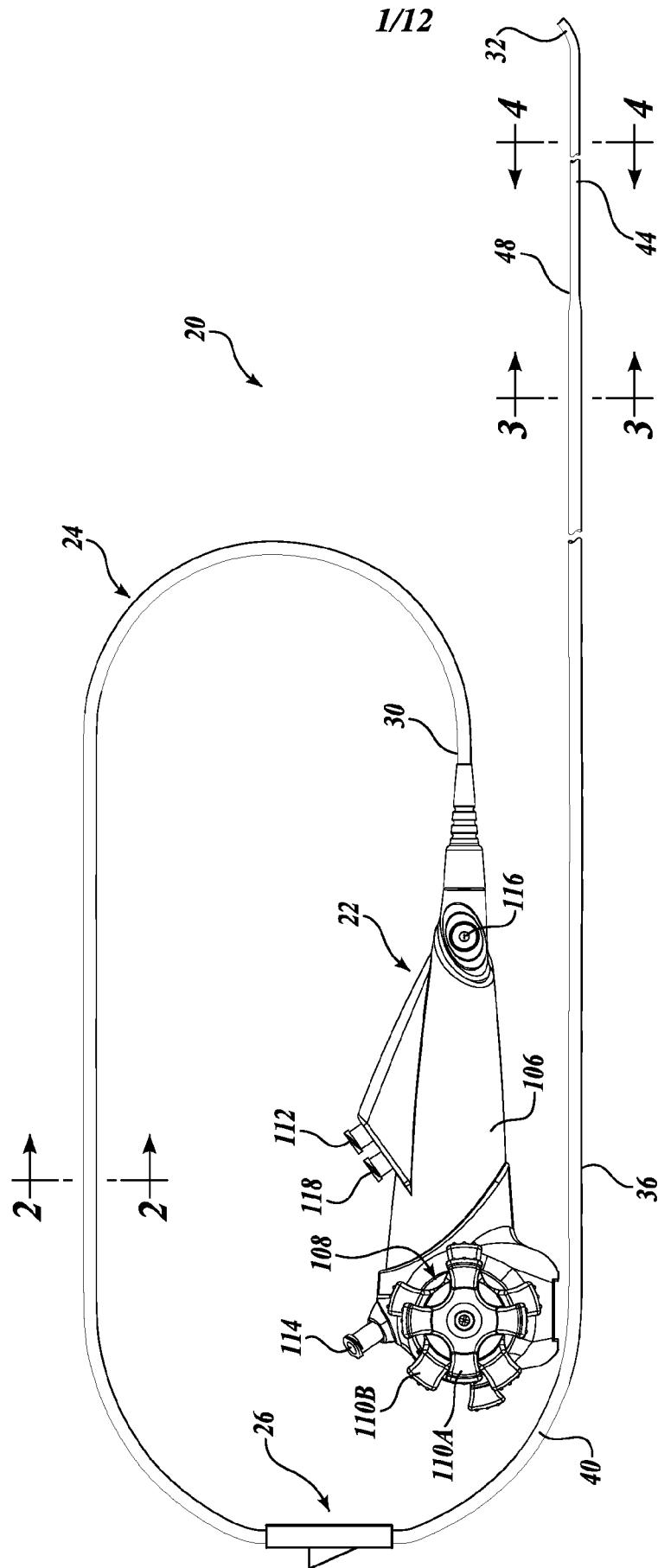
a steering wire channel;

a guide wire opening disposed in communication with the guide wire channel of the shaft such that a guide wire may be insertable into the guide wire opening and routed into the guide wire channel; and

means disposed along a portion of the shaft for allowing a guide wire to radially exit the shaft.

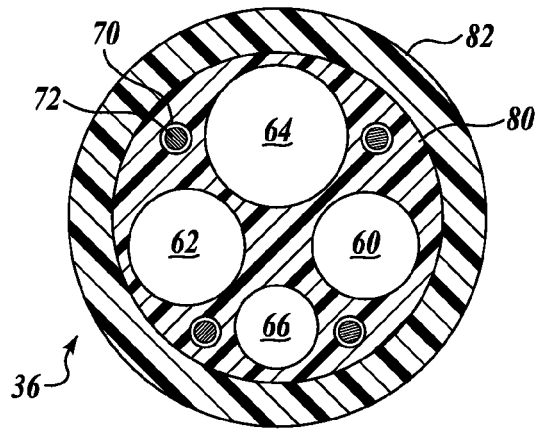
49. A catheter assembly comprising a catheter handle functionally connected to any one of the catheters of Claims 1-48.



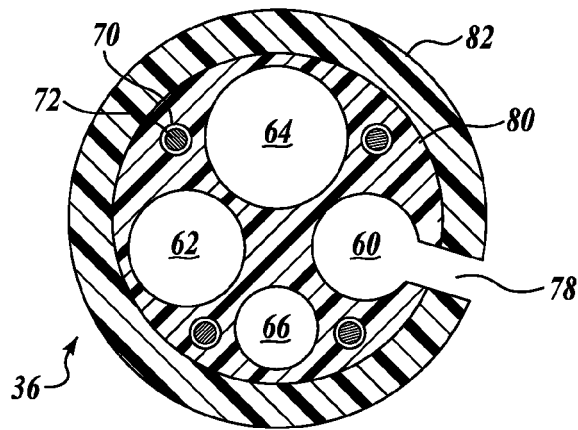


**Fig. 1.**

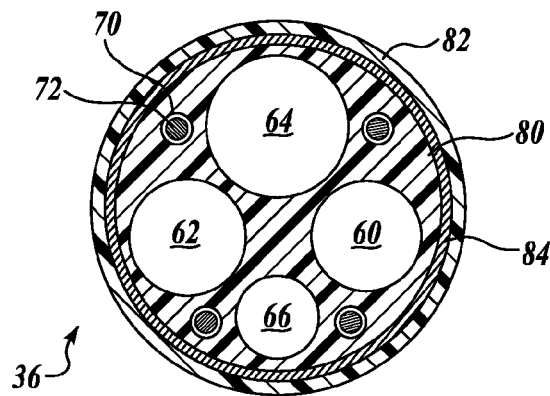
2/12



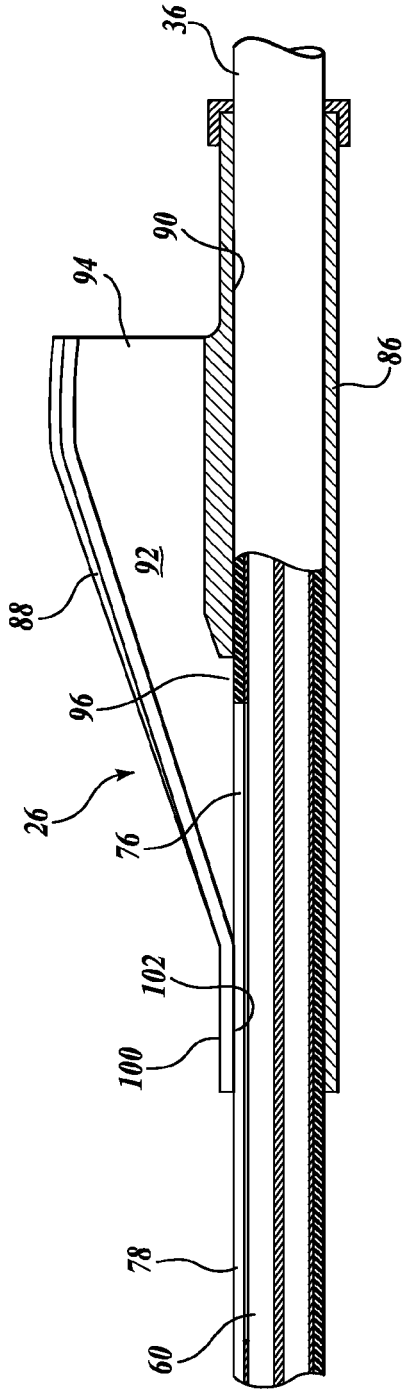
*Fig. 2.*



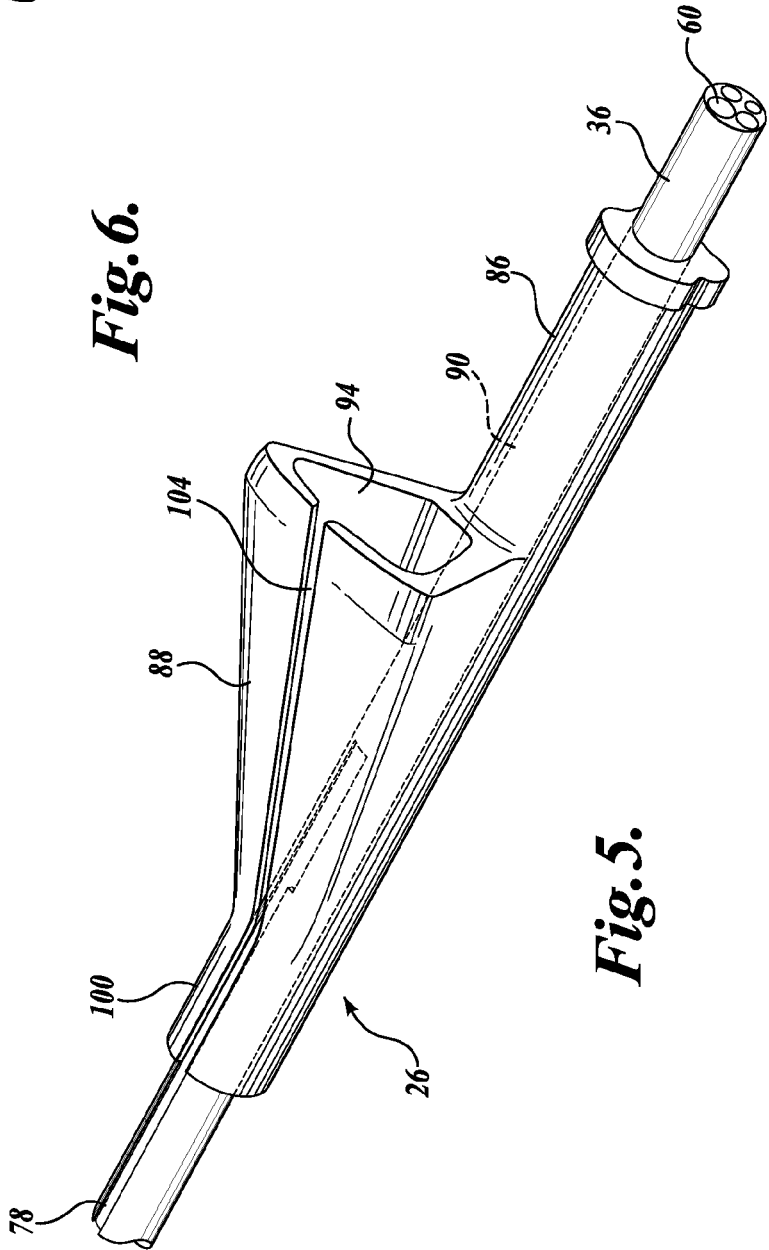
*Fig. 3.*



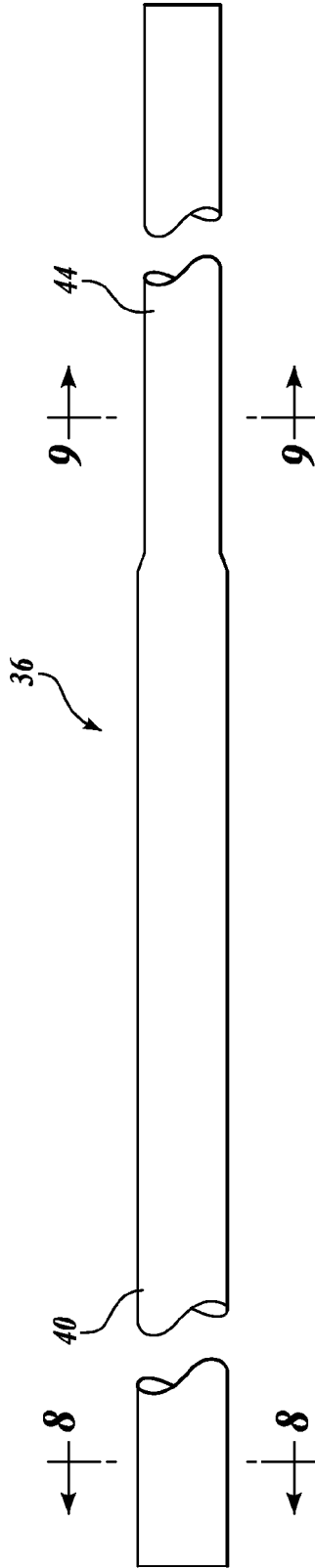
*Fig. 4.*



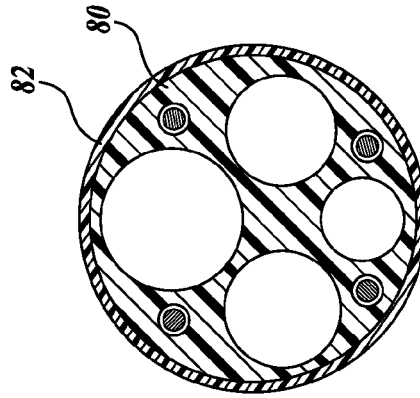
**Fig. 6.**



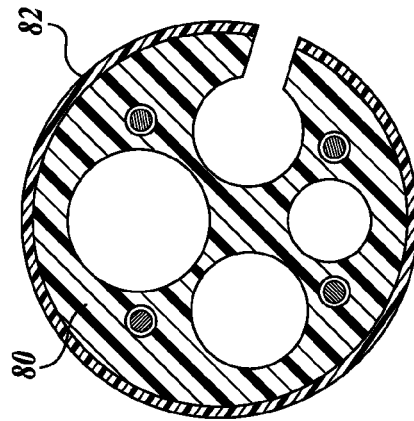
**Fig. 5.**



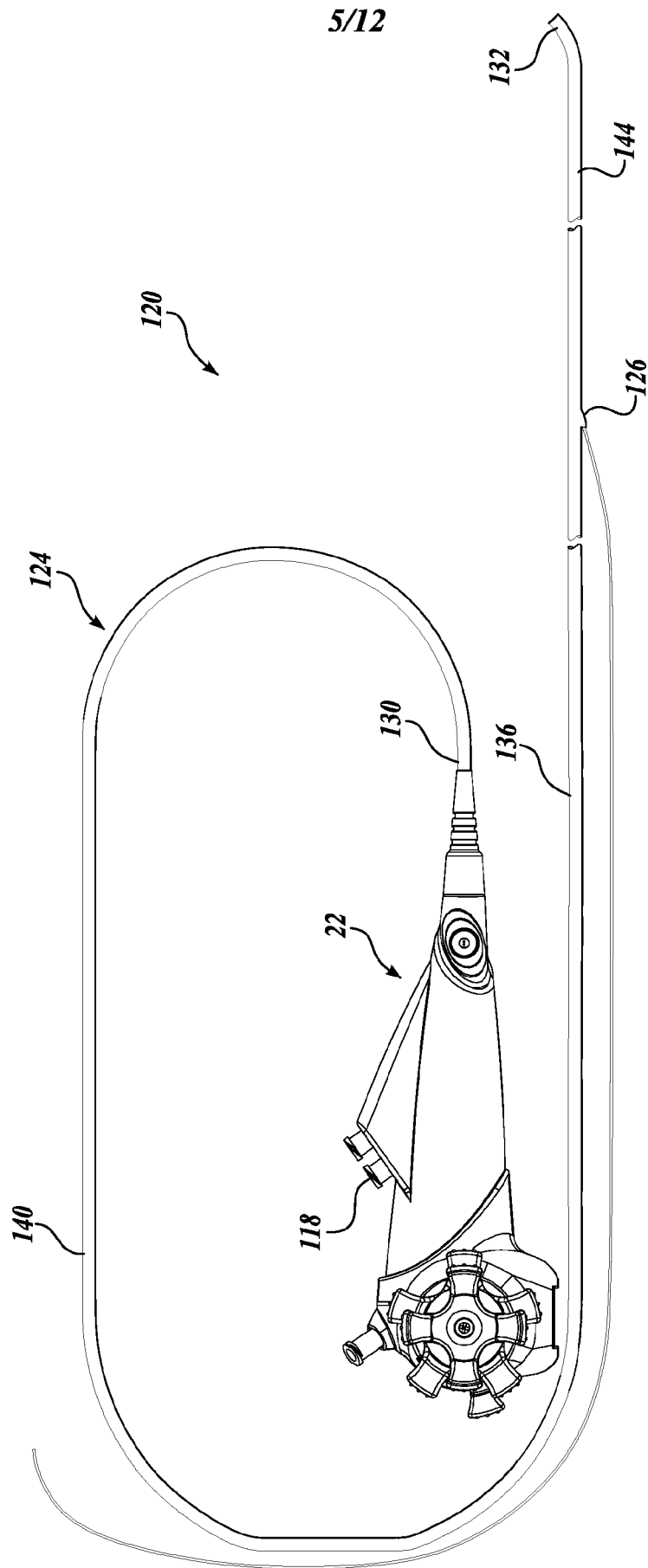
**Fig. 7.**



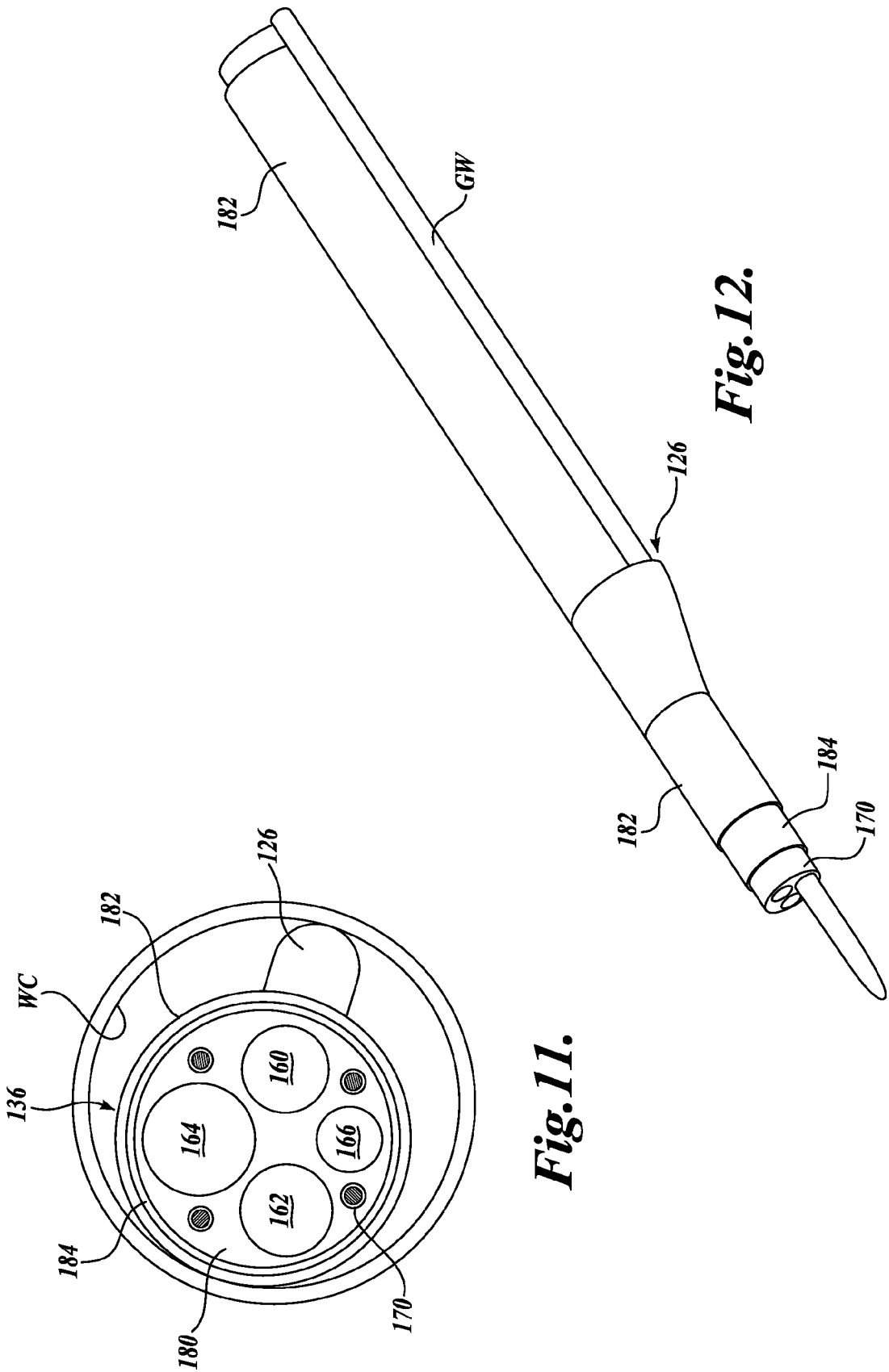
**Fig. 9.**



**Fig. 8.**



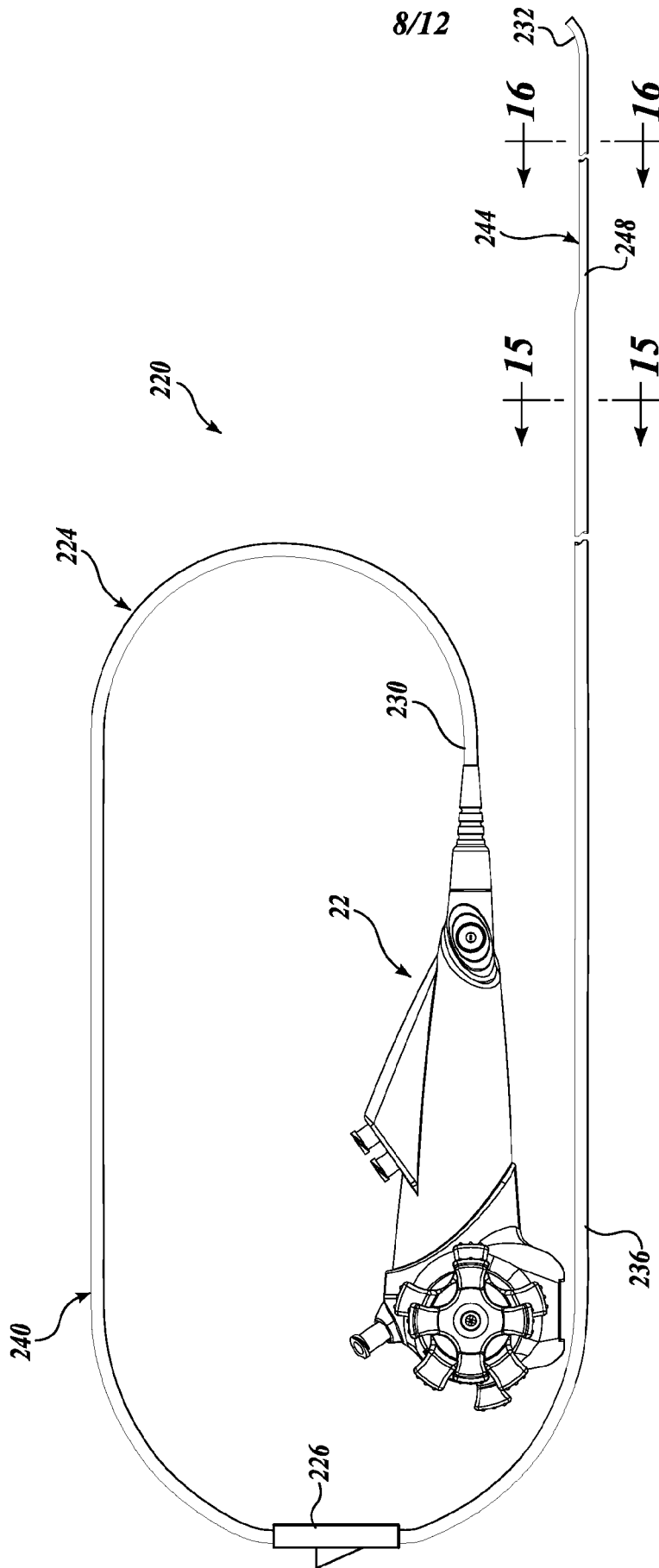
**Fig. 10.**



**Fig. 11.**

**Fig. 12.**

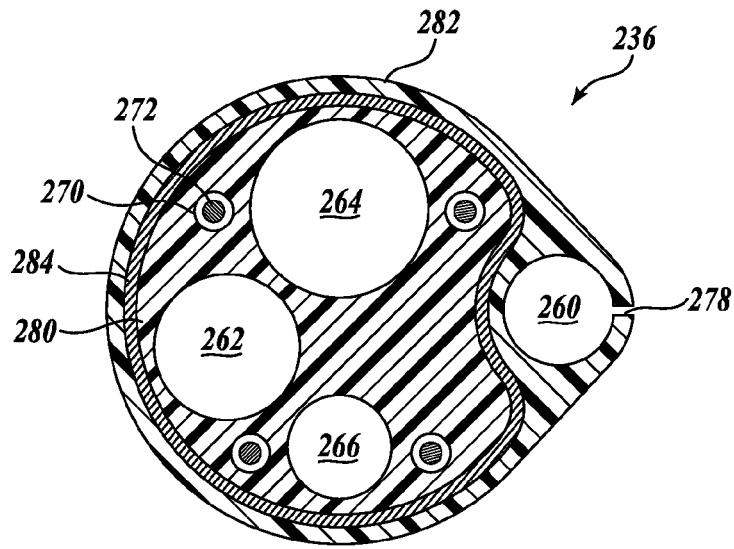




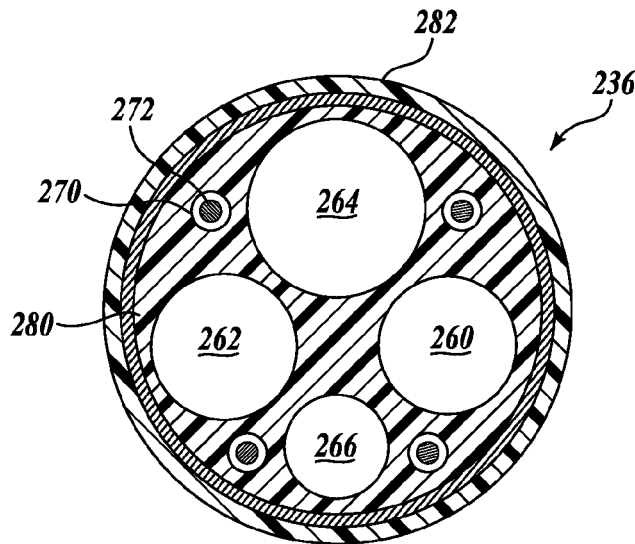
**Fig. 14.**



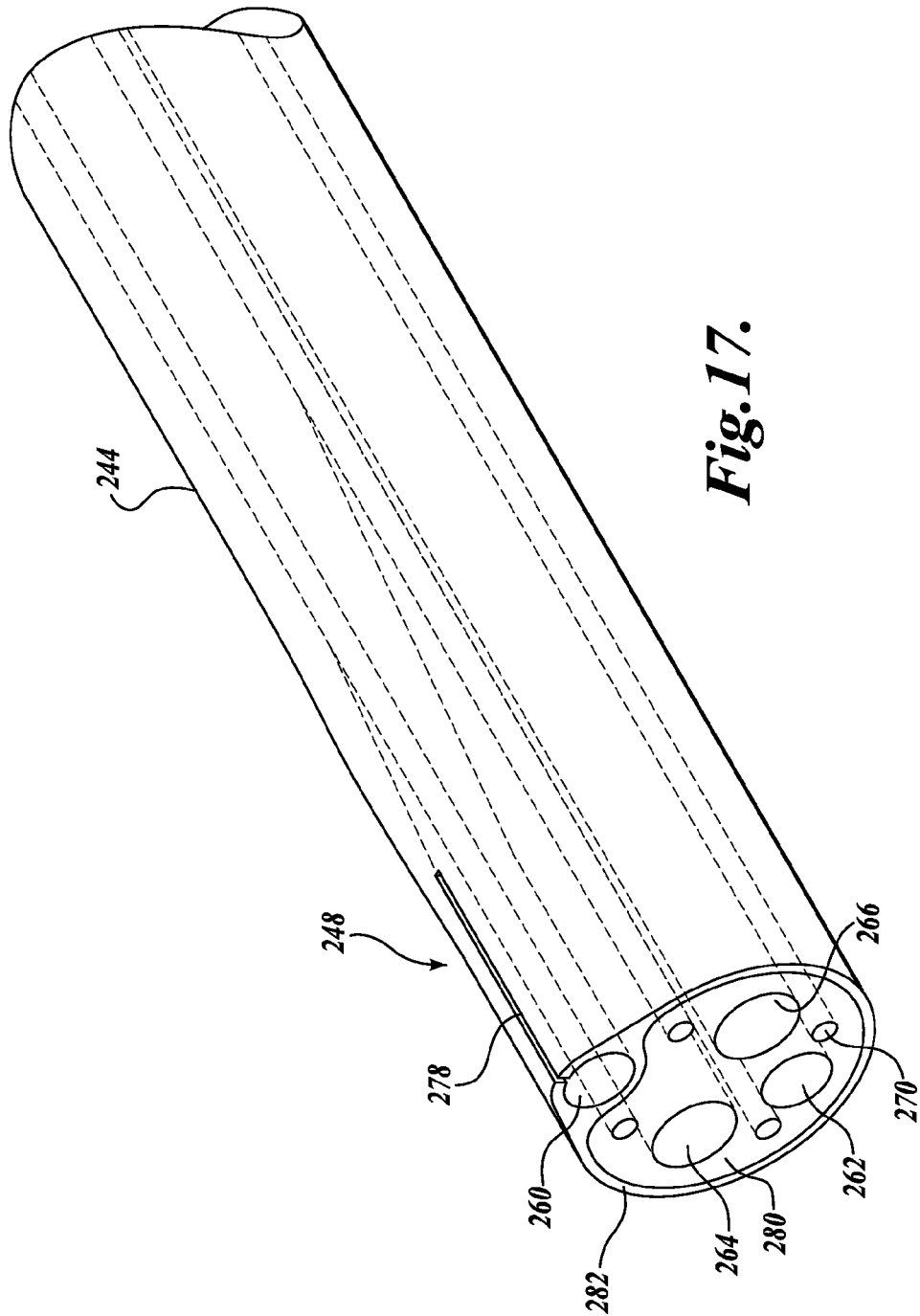
9/12



**Fig.15.**

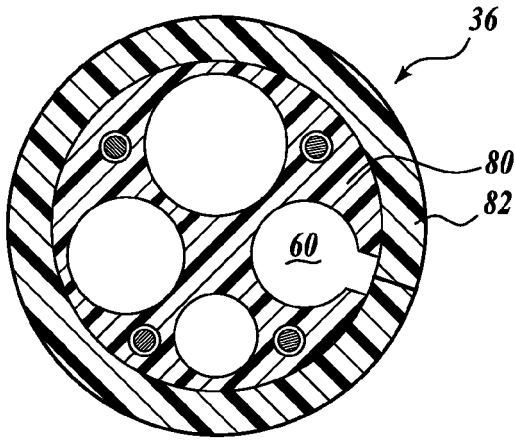


**Fig.16.**

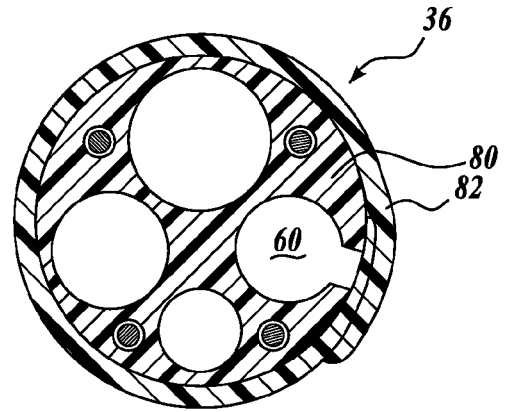


**Fig. 17.**

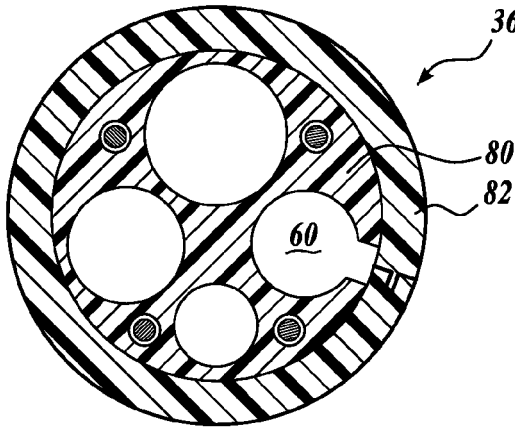
11/12



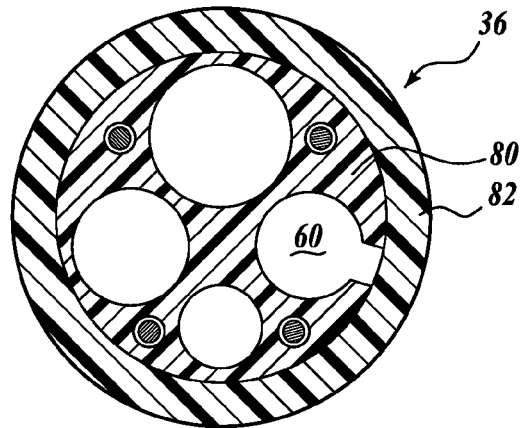
*Fig. 18A.*



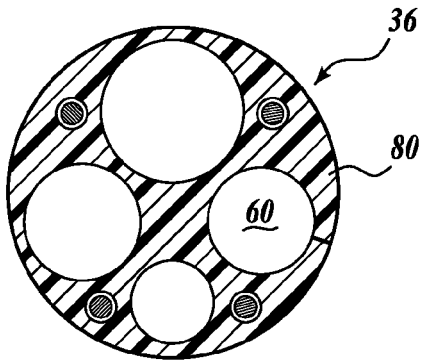
*Fig. 18B.*



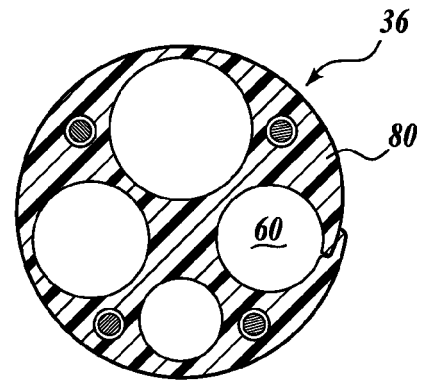
*Fig. 18C.*



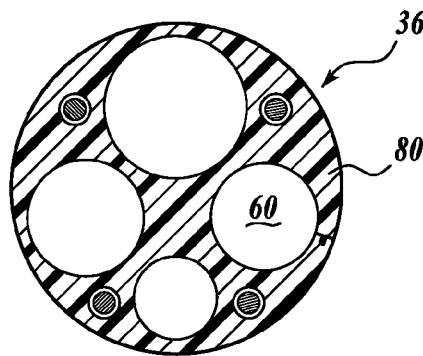
*Fig. 18D.*



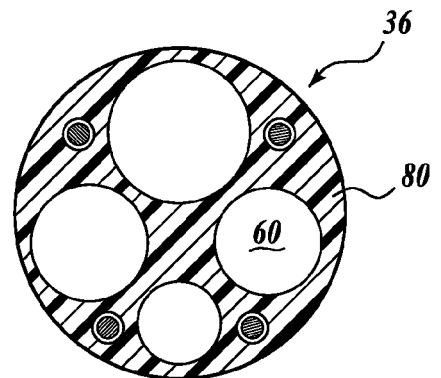
*Fig. 19A.*



*Fig. 19B.*



*Fig. 19C.*



*Fig. 19D.*

# INTERNATIONAL SEARCH REPORT

International application No

PCT/US2009/031014

**A. CLASSIFICATION OF SUBJECT MATTER**  
 INV. A61M25/00 A61M25/01

According to International Patent Classification (IPC) or to both national classification and IPC

**B. FIELDS SEARCHED**

Minimum documentation searched (classification system followed by classification symbols)  
 A61M

Documentation searched other than minimum documentation to the extent that such documents are included in the fields searched

Electronic data base consulted during the international search (name of data base and, where practical, search terms used)

EPO-Internal, WPI Data

**C. DOCUMENTS CONSIDERED TO BE RELEVANT**

Category*	Citation of document, with indication, where appropriate, of the relevant passages	Relevant to claim No.
X	WO 00/69499 A (SCIMED LIFE SYSTEMS INC [US]) 23 November 2000 (2000-11-23)	1,2,4-17
Y	figures 1,1a,1b,1c,1d,1e,2a,2b,2c,2d,6,20b,21b,22b,20c pages 1-5 pages 35-39	27-48
X	WO 02/096483 A (AVANTEC VASCULAR CORP [US]) 5 December 2002 (2002-12-05) all figures pages 11-18	1,2,4-17
X	US 5 395 335 A (JANG G DAVID [US]) 7 March 1995 (1995-03-07) figures 1-6,1a,1b,1c,29-33 columns 4-12 columns 17-19	1,2,4-17
	----- -/--	

Further documents are listed in the continuation of Box C.

See patent family annex.

\* Special categories of cited documents:

- \*A\* document defining the general state of the art which is not considered to be of particular relevance
- \*E\* earlier document but published on or after the international filing date
- \*L\* document which may throw doubts on priority claim(s) or which is cited to establish the publication date of another citation or other special reason (as specified)
- \*O\* document referring to an oral disclosure, use, exhibition or other means
- \*P\* document published prior to the international filing date but later than the priority date claimed

- \*T\* later document published after the international filing date or priority date and not in conflict with the application but cited to understand the principle or theory underlying the invention
- \*X\* document of particular relevance; the claimed invention cannot be considered novel or cannot be considered to involve an inventive step when the document is taken alone
- \*Y\* document of particular relevance; the claimed invention cannot be considered to involve an inventive step when the document is combined with one or more other such documents, such combination being obvious to a person skilled in the art.
- \*&\* document member of the same patent family

Date of the actual completion of the international search

27 May 2009

Date of mailing of the international search report

05/06/2009

Name and mailing address of the ISA/

European Patent Office, P.B. 5818 Patentlaan 2  
 NL - 2280 HV Rijswijk  
 Tel. (+31-70) 340-2040,  
 Fax: (+31-70) 340-3016

Authorized officer

Rodrigues, Elodie

4

## INTERNATIONAL SEARCH REPORT

International application No

PCT/US2009/031014

C(Continuation). DOCUMENTS CONSIDERED TO BE RELEVANT

Category*	Citation of document, with indication, where appropriate, of the relevant passages	Relevant to claim No.
X ..	US 5 180 368 A (GARRISON MICH E [US]) 19 January 1993 (1993-01-19) the whole document	1,3,6, 12-17
X	US 5 456 680 A (TAYLOR KEVIN D [US] ET AL) 10 October 1995 (1995-10-10) the whole document	1,3,6, 12-17
X	US 2004/102719 A1 (KEITH PETER T [US] ET AL) 27 May 2004 (2004-05-27)	1,3, 5-17,26, 48,49
Y	figures 9a,9b,9c,9d,9e,11a,11b,13a,13b,13c,13d paragraphs [0001] - [0017] paragraphs [0056] - [0100]	26,48,49
X	WO 93/18818 A (SPECTRANETICS CORP [US]) 30 September 1993 (1993-09-30) figures 1-4,5a,5b,7,8c pages 1-5 pages 7-14	1,3,7,8, 12-17
P,X	WO 2008/033589 A (BOSTON SCIENT SCIMED INC [US]) 20 March 2008 (2008-03-20) the whole document	1-17, 26-49
Y	EP 0 904 795 A (CORDIS WEBSTER INC [US]) 31 March 1999 (1999-03-31) the whole document	26-49
Y	EP 1 532 998 A (TERUMO CORP [JP]) 25 May 2005 (2005-05-25) the whole document	26-49
Y	WO 01/49356 A (BEDELL RAYMOND L [US]) 12 July 2001 (2001-07-12) figures 1,2 pages 7-18	26-49
Y	WO 03/101287 A (UNIV LELAND STANFORD JUNIOR [US]) 11 December 2003 (2003-12-11) figures 8a,8b,8c page 15, line 17 - page 19, line 16	26-49
Y	WO 01/89624 A (BARD INC C R [US]; AZNOIAN HAROLD M [US]; LEBLANC MICHAEL [US]) 29 November 2001 (2001-11-29) the whole document	26-49
A	WO 03/047447 A (WILSON COOK MEDICAL INC [US]) 12 June 2003 (2003-06-12) the whole document	29-49

# INTERNATIONAL SEARCH REPORT

International application No.  
PCT/US2009/031014

## Box No. II Observations where certain claims were found unsearchable (Continuation of item 2 of first sheet)

This international search report has not been established in respect of certain claims under Article 17(2)(a) for the following reasons:

1.  Claims Nos.:  
because they relate to subject matter not required to be searched by this Authority, namely:
  
2.  Claims Nos.:  
because they relate to parts of the international application that do not comply with the prescribed requirements to such an extent that no meaningful international search can be carried out, specifically:
  
3.  Claims Nos.:  
because they are dependent claims and are not drafted in accordance with the second and third sentences of Rule 6.4(a).

## Box No. III Observations where unity of invention is lacking (Continuation of item 3 of first sheet)

This International Searching Authority found multiple inventions in this international application, as follows:

see additional sheet

1.  As all required additional search fees were timely paid by the applicant, this international search report covers allsearchable claims.
2.  As all searchable claims could be searched without effort justifying an additional fees, this Authority did not invite payment of additional fees.
3.  As only some of the required additional search fees were timely paid by the applicant, this international search report covers only those claims for which fees were paid, specifically claims Nos.:  
  
1-17, 26-49
4.  No required additional search fees were timely paid by the applicant. Consequently, this international search report is restricted to the invention first mentioned in the claims; it is covered by claims Nos.:

### Remark on Protest

- The additional search fees were accompanied by the applicant's protest and, where applicable, the payment of a protest fee.
- The additional search fees were accompanied by the applicant's protest but the applicable protest fee was not paid within the time limit specified in the invitation.
- No protest accompanied the payment of additional search fees.

**FURTHER INFORMATION CONTINUED FROM PCT/ISA/ 210**

This International Searching Authority found multiple (groups of) inventions in this international application, as follows:

1. claims: 1-17

Catheter with a guidewire channel, at least one channel and a guidewire opening such that the guidewire may radially exit the shaft.

2. claims: 18-22

Catheter with a guidewire channel, at least one channel and a deflector.

3. claim: 23

Catheter with a guidewire channel, an optical channel and a guidewire opening such that the guidewire may radially exit the shaft.

4. claim: 24

Catheter with a shaft comprising a core body, an outer sleeve and a reinforcement sheath in between, a guidewire channel and a guidewire opening such that the guidewire may radially exit the shaft.

5. claim: 25

Catheter with a guidewire channel, at least 2 channels, a guidewire opening and a rapid exchange channel section.

6. claims: 26-49

Catheter with a steering wire, a guidewire channel such that the guidewire may radially exit the shaft.



## INTERNATIONAL SEARCH REPORT

Information on patent family members

International application No

PCT/US2009/031014

Patent document cited in search report		Publication date	Patent family member(s)	Publication date
WO 0069499	A	23-11-2000	AU 776988 B2	30-09-2004
			AU 4173200 A	05-12-2000
			CA 2340625 A1	23-11-2000
			DE 60024206 D1	29-12-2005
			DE 60024206 T2	03-08-2006
			EP 1096967 A1	09-05-2001
			JP 4219563 B2	04-02-2009
			JP 2002543937 T	24-12-2002
WO 02096483	A	05-12-2002	EP 1390095 A2	25-02-2004
			JP 2004528126 T	16-09-2004
US 5395335	A	07-03-1995	US 5554118 A	10-09-1996
US 5180368	A	19-01-1993	NONE	
US 5456680	A	10-10-1995	NONE	
US 2004102719	A1	27-05-2004	AU 2003291032 A1	18-06-2004
			EP 1562666 A2	17-08-2005
			JP 2006507089 T	02-03-2006
			WO 2004047901 A2	10-06-2004
			US 2009005755 A1	01-01-2009
WO 9318818	A	30-09-1993	CA 2103252 A1	19-09-1993
			EP 0587859 A1	23-03-1994
			JP 6511181 T	15-12-1994
			JP 2003038653 A	12-02-2003
			US 5429604 A	04-07-1995
WO 2008033589	A	20-03-2008	EP 2061542 A1	27-05-2009
			US 2008097293 A1	24-04-2008
EP 0904795	A	31-03-1999	JP 4209003 B2	14-01-2009
			JP 11164892 A	22-06-1999
EP 1532998	A	25-05-2005	NONE	
WO 0149356	A	12-07-2001	AU 2632001 A	16-07-2001
			CA 2395924 A1	12-07-2001
WO 03101287	A	11-12-2003	AU 2003240831 A1	19-12-2003
			EP 1513440 A2	16-03-2005
			EP 1870018 A2	26-12-2007
			US 2006084839 A1	20-04-2006
			US 2007015964 A1	18-01-2007
			US 2004097788 A1	20-05-2004
WO 0189624	A	29-11-2001	EP 1286721 A1	05-03-2003
			JP 2004520854 T	15-07-2004
WO 03047447	A	12-06-2003	AU 2002346622 A1	17-06-2003
			US 2003130679 A1	10-07-2003