



(12) **EUROPEAN PATENT APPLICATION**

(43) Date of publication:
14.04.2010 Bulletin 2010/15

(51) Int Cl.:
F24C 15/20 (2006.01)

(21) Application number: **08166293.4**

(22) Date of filing: **09.10.2008**

(84) Designated Contracting States:
AT BE BG CH CY CZ DE DK EE ES FI FR GB GR HR HU IE IS IT LI LT LU LV MC MT NL NO PL PT RO SE SI SK TR
 Designated Extension States:
AL BA MK RS

(71) Applicant: **Huang, Rong Fung**
Wunshan District
Taipei County (TW)

(72) Inventor: **Huang, Rong Fung**
Wunshan District
Taipei County (TW)

(74) Representative: **Meyer, Ludgerus**
Jungfernstieg 38
20354 Hamburg (DE)

(54) **Pollutant removing device and oblique single air curtain range hood using the device**

(57) The present invention relates to a pollutant removing device and an oblique single air curtain range hood using the device. The rear side of the range hood is adjacent to a wall and the range hood includes an air blow device and a suction device. The air blow device has an elongated air blow slot that is provided in front of a counter top and through which air is blown upward. The suction device is located above the counter top and includes an elongated suction opening that is connected with a suction machine to produce upward suction force. The elongated suction opening is parallel to the elongat-

ed air blow slot in a way that the elongated suction opening is above and spaced from the elongated air blow slot toward the wall. By means of the operation of the suction machine, an oblique air curtain that is nearly two-dimensional is formed between the elongated suction opening and the elongated air blow slot. The gas or harmful gas located between the oblique air curtain and the wall can be sucked via the elongated suction opening. Consequently, the escape of pollutants is decreased and the ability against interference of sucking harmful gas resulted from ambient air turbulence can be enhanced.

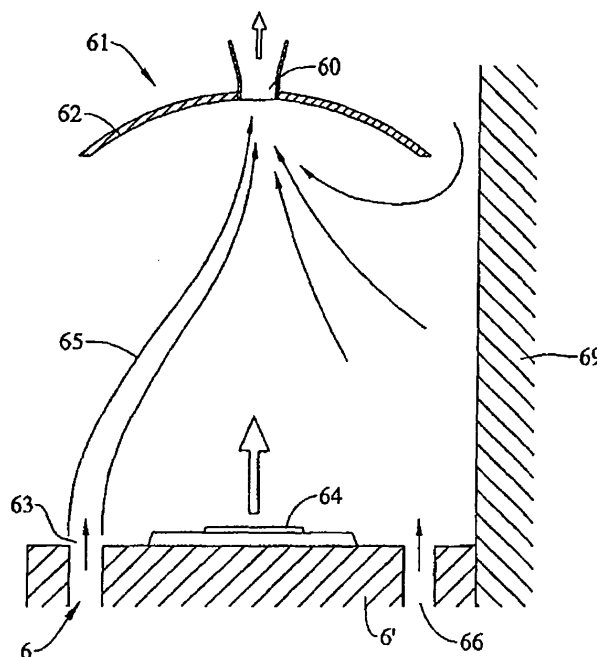

Fig. 6

Description

Field of the invention

[0001] The present invention relates to a device for removing gas, vapor, particulate, or mixed type pollutants, and more particularly, to a range hood generating an oblique air curtain above a counter top so as to remove pollutants between the oblique air curtain and a wall.

Background of the invention

[0002] Generally, kitchens, laboratories or dust factories generate gas with grease particles or toxic gases that are harmful to the people in the sites and pollutes the surroundings.

[0003] Take a conventional kitchen hood as an example. As shown in Fig.12, the hood 10 is fixed to an underside of the cabinet 15 in which a pipe 12 is received. The pipe 12 guides the gas sucked by the hood from the cook ware and expels the gas out of the kitchen. The cabinet 15 is connected with other cabinet 16 on the wall 14 to which the hood 10 is connected and the other wall 13 that is perpendicular to the wall 14 is in contact with a side of the hood 10. The oven 18 is installed in the counter top 17 and includes two burners 19. The counter top 17 is connected on the top of yet another cabinet 20. The hood 10 includes two suction fans 11 which are located above the burners 19 so as to suck the gas from the cookware into the hood 10 and the gas can be expelled outside the kitchen via the pipe 12.

[0004] The conventional range hoods 10 used in kitchens are similar to canopy hoods that are used in working sites. As shown in Fig.13, the upward speed of the gas flow decreases quickly with the increase of the downward distance beneath the suction face. At the distance further than about 1.5 times of the diameter of the suction opening, the upward velocity becomes negligibly small and the suction force would not be large enough to draw effectively the gas. Therefore, the effective suction distance beneath the canopy hood is generally within about 1.5 times of the diameter of the suction opening. Besides, because of the characteristics of the suction flow field of the canopy hoods, the gas flow can easily be affected by drafts such as the air flows generated from fans, air conditioning device, people walking by, opening or closing doors or windows, and so forth. When such interference airflow exists, as shown in Fig. 14, the flow field beneath the canopy hood would be modified drastically and the capture zone will become an area like the half-oval enclosed in a dividing streamline. The larger the ratio of the interference air flow speed to the suction speed presents, the smaller the capture zone becomes. When this situation happens, the grease particles, toxic gases, or pollutants originally generated under the hood are extremely tentative to be dispersed to the environment and therefore are more easily attached to the wall and inhaled by the users. One of the most intuitive ways to avoid occur-

ring this situation is to install the canopy hood as low as possible towards the position of the pollutants. In practical applications, however, the hood cannot be installed too low because movements and operations of cook wares or apparatus by hands or tools in the room between the table top and the canopy hood are commonly required. Because that the draft currents generated by fans, air conditioning device, people walking by, opening or closing doors or windows almost exists around the hood all the time, the conventional hood therefore can hardly have satisfied performance.

[0005] Fig.15 shows an improved range hood wherein three cross-flow fans 21 are installed on the front side, left side, and right side of the oven to provide three upward-issuing slot jets. This design is aimed to use the three cross-flow fans 21 cooperated with the back wall 14 to reduce the negative effects of the draft currents generated in the environment. However, because the area above the oven is enclosed by the three jets generated by the three fans 21 and the back wall 14, the pollutants around the lower portion of the enclosed area would present unsteady, chaotic flow motions with violent three-dimensional tumbling and swirling vortices. The reason why this arrangement would inevitably induce instability of flow is the unbalanced mass and momentum conservation laws. The induced turbulent dispersion would therefore reduce the efficiency of pollutant removal through the canopy hood installed at a distance above the oven. Because the residence time of the grease particles and pollutants staying around the area above the oven becomes much longer due to the vortical motion of the flow, it becomes very dangerous when the draft currents pass over, that is, the high-concentration grease particles and pollutants accumulated in that area may be dispersed by the cross flow. Besides, the chaotic motions of the vortical flow structures induced by the three cross-flow fans may affect the flames of the burners, e.g., drift or extinguishment of flames, and reduce the burning efficiency.

[0006] As mentioned above, conventional kitchen hoods cannot effectively remove the gas as a result of the poor fluid dynamics of the airflow generated by the conventional kitchen hoods.

Summary of the invention

[0007] One object of the present invention is to provide a gaseous, vapor, particulate, or mixed type pollutant removing device including an elongate air blow slot provided at one side of a counter top and an elongate suction device that is laterally above and parallel to the elongate air blow slot. Consequently, an oblique air curtain can be formed to eliminate pollutants (such as the gaseous, vapor, or particulate type pollutants) generated between the oblique single air curtain and a wall in order to decrease gas escape and enhance the ability against the inference resulted from ambient air turbulence.

[0008] Another object of the present invention is to pro-

vide an oblique single air curtain range hood having an elongate air blow slot located in front of a counter top at the back of which is disposed with a wall. Besides, an elongate suction opening is provided obliquely above the elongate air blow slot. By this arrangement, the compensation air is naturally provided into the capture zone from two "open sides" of the air curtain so that the flow field would behave more like "two-dimensional" although in strict sense it is not. The three-dimensional, unsteady tumble and swirl vortical flows would not appear so that the pollutants generated between the air curtain and the wall can be effectively sucked by the elongate suction device located at a distance above the counter top and the influences on the flames can be reduced.

[0009] In order to achieve the objects mentioned above, the present invention provides a pollutant removing device, which comprises an air blow device and a suction device and the back of which is placed adjacent to a wall. The air blow device is provided with an elongate air blow slot that is located in front of the pollutant discharge outlet of a counter top and through which air is blown upward. The suction device is located above the counter top and includes an elongate suction opening that is connected with a suction machine, where the elongate suction opening is parallel to the elongate air blow slot in a way that the elongate suction opening is above and spaced from the elongate air blow slot toward the wall.

[0010] The present invention also provides an oblique single air curtain range hood, which comprises an air blow device and a suction device and the back of which is adjacent to a wall. The air blow device is provided with an elongate air blow slot that is located on a counter top and in front of an oven, where air is blown upward through the slot. The suction device is located above the counter top and includes an elongate suction opening that is connected with a suction machine, where the elongate suction opening is parallel to the elongate air blow slot in a way that the elongate suction opening is above and spaced from the elongate air blow slot toward the wall.

[0011] Accordingly, when the suction machine is operated, air can be drawn in by the elongate suction opening and blown through the elongate air blow slot to form a nearly two dimensional oblique air curtain, so that gas escape is decreased and the ability against the inference resulted from ambient air turbulence is enhanced.

[0012] The present invention will become more obvious from the following description when taken in connection with the accompanying drawings that show, for purposes of illustration only, a preferred embodiment in accordance with the present invention.

Brief description of the drawings

[0013] Figs.1A-1C show the basic theory used in the pull-push air curtains of the present invention;

[0014] Fig.2 is a side view to show the pollutant removing device of the present invention;

[0015] Fig.3 shows the flow field results of the embodiment of the pollutant removing device of the present invention tested by laser Doppler velocimeter (LDV).

5 **[0016]** Figs.4-6 are sectional views showing three different embodiments of the pollutant removing device of the present invention.

[0017] Figs.7 is a schematic view showing an embodiment of an oblique single air curtain range hood of the present invention in use.

10 **[0018]** Fig.8 shows the results of capture efficiencies by using a large upright board to simulate drafts generated by fan, air conditioner, or walk-by of people for both of the hood of the present invention and the conventional hood.

15 **[0019]** Figs.9 is a schematic view showing another embodiment of the oblique single air curtain range hood of the present invention in use.

[0020] Fig. 10 shows the oil collection device used in the hood of the present invention.

20 **[0021]** Fig. 11 shows a cross sectional view of the connection of the oil collection device and the hood of the present invention.

[0022] Fig. 12 shows a conventional range hood.

25 **[0023]** Fig. 13 shows the non-dimensional upward velocity on central axis under hood opening when tested by laser Doppler velocimeter.

[0024] Fig. 14 shows the capture zone of a conventional hood subject to influence of cross draft when tested by laser Doppler velocimeter.

30 **[0025]** Fig. 15 shows the conventional range hood with left, right and front upward-blowing jets.

Detailed description of the preferred embodiment

35 **[0026]** Figs. 1A-1C show the hand sketches of the simplified flow fields associated to a planar jet, a suction slot, and a combination of the jet and the suction slot, respectively. As shown in Fig. 1A, a jet 50 is ejected from a nozzle 51 from the left to the right. During the evolution process the environmental air nearby the jet 50 would be entrained inward through the jet boundary. The jet 50 therefore will expand outward in the downstream area. The fashion of expansion will depend on the characteristic regimes of Reynolds number. Downstream the nozzle 51 within a distance about 80 nozzle diameters, the momentum conservation is usually observed. The jet may expand, break up and disperse quickly after a distance about 100~150 nozzle diameters downstream the nozzle 51. During the evolution processes of the jet 50, continuous exchanges of momentum, mass, and heat happen between the jet 50 and the nearby environmental air. As shown in Fig. 1 B, a suction slot 53 draws air from the left to the right. The air flows around the suction slot 53 are denoted by reference 52. The active suction area is located within a downstream distance from the suction slot 53 to about only 1.5 times diameters of the suction slot 53, as mentioned previously. Individual use of the jet usually leads to early dispersion and individual use of the

suction slot usually leads to poor suction capability at the distance beyond the effective suction range. As shown in Fig. 1C, when a jet 50 and a suction slot 53 are arranged face to face at a distance, the flow field in-between the two physical devices varies with the suction strength provided by the suction slot 53 and the Reynolds number of the jet issued from the nozzle 51. If the factors mentioned above are properly adjusted, the poor suction capability of the individual suction slot beyond the effective suction range and the early dispersion characteristics of the individual jet can be improved by the interaction between the jet and the suction which is called the push-pull effect. As this happens, an air curtain which can resist the interference of side drafts to some levels can be established.

[0027] As shown in Fig. 2, a preferable embodiment of the pollutant removing device of the present invention comprises an air blow device 6 and a suction device 61 and the back thereof is adjacent to a wall 69. The air blow device 6 is provided with an elongate air blow slot 63 that is located in front of the pollutant discharge outlet 64 of a counter top 6' and through which air is blown upward. The suction device 61 is located above the counter top 6' and includes an elongate suction opening 60. The elongate suction opening 60 forms a suction port facing downward and is connected with a suction machine (not shown in this figure) for drawing in air. Besides, the elongate suction opening 60 is parallel to the elongate air blow slot 63 in a way that the elongate suction opening 60 is above and spaced from the elongate air blow slot 63 toward the wall. In practice, the elongate suction opening 60 can be formed by aligning plural suction holes.

[0028] A rectangular suction device 61 is located at a distance from the counter top 6' and two curved flanges 62 extend from two sides of the elongate suction opening 60 of the suction device 61. The upward-blowing jets issued from the elongate air blow slot 63 located at the front end of the counter top 6' associated with the upward-drawing suction flow induced by the elongate suction opening 60 form the upward inclined air curtain 65 as shown in Figs.3, so that the air between the air curtain 65 and the wall 69 can be pushed smoothly upward and vented outside through the elongate suction opening 60. The two sides above the counter top 6' are left open or equipped with grids or porous boards through which the compensation air can be naturally provided into the area between the oblique single air curtain 65 and the wall 69 as shown in Fig.3, so that the air flows are steady.

[0029] When in practice, a flange 62 at one side of the elongate suction opening 60 extending toward the wall 69 can be a flat plate and one side of the flat plate is against the surface of the wall. The flange 62 can also include a fixing plate 621 and a telescopic plate 622 as shown in Fig.4. The fixing plate 621 extends from one side of the elongate suction opening 60 toward the wall 69. The telescopic plate 622 is able to be extended or retracted relative to the fixing plate 621 to make the space between the suction device 61 and the wall 69 exposed

or enclosed.

[0030] Moreover, as shown in Fig.5, the air is blown from the elongate air blow slot 63 in a direction 631 that is preferably toward the wall 69 and is tilted relative to the counter top at an angle of θ° .

[0031] In practice, as shown in Fig.6, another elongate air blow slot 66 can be provided at the back of the pollutant discharge outlet 64 of the counter top 6', that is, be provided between the elongate air blow slot 63 and the wall 69. Consequently, the two elongate air blow slots 63, 66 are provided at the front and the back of the pollutant discharge outlet 64 of the counter top 6' in a parallel manner and air can be blown upward through these slots 63, 66.

[0032] As shown in Fig.7, an oblique single air curtain range hood, which uses a pollutant removing device and the back of which is adjacent to a wall 82, is disclosed. The range hood comprises an air blow device 7 and a suction device 70. The air blow device 7 is provided with an elongate air blow slot 80 that is located in front of an oven 79 of a counter top 77 and air is blown upward through the elongate air blow slot 80. The suction device 70 is located above the counter top 77 and includes an elongate suction opening 81 that is connected with a suction machine 72. The elongate suction opening 81 is parallel to the elongate air blow slot 80 in a way that the elongate suction opening 81 is above and spaced from the elongate air blow slot 80 toward the wall. In practice, the elongate suction opening 81 can be a grid having plural suction holes.

[0033] The suction device 70 includes an elongate suction opening 81 which forms a suction opening facing downward and two flanges 71 extend from two sides of the elongate suction opening 81. The suction device 70 is located at a certain height from a pedestal 78 so as to provide an upward suction force. The elongate suction opening 81 is connected with a suction machine 72 that is located in the cabinet 75 above the pedestal 78 so as to reduce noise. The pipe 721 is opened to outside of the room or is connected to a filter/oil-separation device/oil-collection device that brings the pollutant out of the room. Besides, two flanges 71 extend from the two sides of the elongate suction opening 81 of the suction device 70. The air blow device 7 is located at the front end of the ovens 79 of the pedestals 78 on the counter top 77. In practice, the air blow device 7 is an elongate air blow groove that is in communication with a blower and the blower is co-operated with the suction machine 72. Besides, the air blow device 7 also can be a cross flow fan that is co-operated with the suction machine 72 to form an upward-blowing air jet.

[0034] By the upward-blowing air jet issued from the air blow device 7 installed at the front end of the oven 79 combined with the upward suction flow generated by the suction device 70 that has the elongate suction opening 81, an oblique single air curtain flow structure can be formed to prevent the pollutant from escaping from the capture area and effectively prevent the grease particles

from attaching on the wall 82 at the back of the pedestal 78. Besides, the two sides above the counter top 77 are opened so that air can be sucked into the area between the single oblique air curtain and the wall to feed the suction action. By this way, the flow field can maintain nearly "two-dimensional." The two sides above the counter top 77 may have porous boards or grids to allow the air be drawn into the area between the single oblique air curtain and the wall 82 with small flow resistance and vented outside through the elongate suction opening 81.

[0035] As shown in Fig.7, the tracer gas method is used to examine the capture efficiencies of the present invention and the conventional range hood. The suction device is installed at different distances from the counter top and a large upright board swings at 0.35 m/s to simulate air flows generated by fan, or air conditioner or by people walking by the counter. Pure SF₆ gas is provided at constant flow rate by a gas releasing device placed on the counter top. The velocity and concentration of the SF₆ are detected at a remote cross section of the suction pipe. The capture efficiency, which is defined as the flow rate of SF₆ passes through the suction pipe divided by the flow rate of pure SF₆ released from the gas releasing device, can be calculated. The result is disclosed in Fig. 8. Obviously, the single oblique air curtain range hood has much higher capture efficiency than that of the conventional range hood. The ability for reducing the interference by the reference flows of the range hood of the present invention is much higher than that of the conventional range hood.

[0036] In practice, as shown in Fig.9, another elongate air blow slot 80' can be provided at the back of the oven 79 of the counter top 77, that is, provided between the elongate air blow slot 80 and the wall 82. Consequently, the two elongate air blow slots 80, 80' are provided at the front and the back of the oven 79 of the counter top 77 in a parallel manner and air can be blown upward through these slots 80, 80'.

[0037] Figs.10 and 11 show an oil collection device 9 that is detachably connected to the elongate suction opening 81 of the suction device 70 so as to collect the oil flowing along insides of the elongate suction opening 81.

[0038] When in practice, the elongate suction opening 81 protrudes a little from the flanges 71 and faces downward. The oil collection device 9 is a rectangular box with an open top and includes a base board 91 from which a first side panel 92, a first upright board 93, a second upright board 94 and a second side panel 95 extend upward. A filter 96 is connected to the base board 91. A first space 97 is defined between the first side panel 92, the first upright board 93 and the base board 91, and a second space 98 is defined between the second side panel 95, the second upright board 94 and the base board 91. Two support plates 99 are located above the filter 96 and connected between the first and second upright boards 93, 94.

[0039] When pushing the oil collection device 9 upward

to engage with the elongate suction opening 81, the first and second side panels 92, 95 are engaged with two outsides of the elongate suction opening 81. When the gas containing pollutants are sucked and passed through the filter 96, the oil mist may be condensed into grease particles and attach on the insides of the elongate suction opening 81. The condensed grease will flow along the insides of the suction device 70 by the effect of gravity and drop into the first and second spaces 97, 98. The grease collected in the first and second spaces 97, 98 can be cleaned by removing the oil collection device 9 from the elongate suction opening 81.

[0040] While we have shown and described the embodiment in accordance with the present invention, it should be clear to those skilled in the art that further embodiments may be made without departing from the scope of the present invention.

Claims

1. A pollutant removing device, the back of which is adjacent to a wall, comprising: an air blow device having an elongate air blow slot that is located in front of a pollutant discharge outlet of a counter top and through which air is blown upward; and

a suction device located above the counter top and including an elongate suction opening that is connected with a suction machine, where the elongate suction opening is parallel to the elongate air blow slot in a way that the elongate suction opening is above and spaced from the elongate air blow slot toward the wall, so that an oblique air curtain that is nearly two-dimensional is formed between the elongate suction opening and the wall when the suction machine is operated to decrease gas escape and enhance the ability against the inference resulted from ambient air turbulence.

2. The device as claimed in claim 1 further including another elongate air blow slot that is parallel to the elongate air blow slot, located at the rear of the pollutant discharge outlet of the counter top, and through which air is blown upward.
3. The device as claimed in claim 1 or 2 further including a flange that is extended from one side of the elongate suction opening toward the wall.
4. The device as claimed in claim 3, wherein the flange includes a fixing plate and a telescopic plate; the fixing plate is extended from one side of the elongate suction opening and the telescopic plate is able to be extended or retracted relative to the fixing plate.
5. The device as claimed in claim 1 or 2, wherein the

direction in which the air is blown from the elongate air blow slot is toward the wall and is tilted relative to the counter top.

6. A oblique single air curtain range hood, which uses a pollutant removing device and the back of which is adjacent to a wall, comprising:

an air blow device that is provided with an elongate air blow slot that is located on a counter top and in front of an oven, where air is blown upward through the slot; and
 a suction device located above the counter top and including an elongate suction opening that is connected with a suction machine, where the elongate suction opening is parallel to the elongate air blow slot in a way that the elongate suction opening is above and spaced from the elongate air blow slot toward the wall, so that an oblique air curtain that is nearly two-dimensional is formed between the elongate suction opening and the wall when the suction machine is operated to decrease gas escape and enhance the ability against the inference resulted from ambient air turbulence.

7. The oblique single air curtain range hood as claimed in claim 6 further including another elongate air blow slot that is parallel to the elongate air blow slot, located at the rear of the pollutant discharge outlet of the counter top, and through which air is blown upward.

8. The oblique single air curtain range hood as claimed in claim 6 or 7 further including a flange that is extended from one side of the elongate suction opening toward the wall.

9. The oblique single air curtain range hood as claimed in claim 8, wherein the flange includes a fixing plate and a telescopic plate; the fixing plate is extended from one side of the elongate suction opening and the telescopic plate is able to be extended or retracted relative to the fixing plate.

10. The oblique single air curtain range hood as claimed in claim 6 or 7, wherein the direction in which the air is blown is toward the wall and is tilted relative to the counter top.

11. The oblique single air curtain range hood as claimed in claim 6 or 7, wherein the air blow device is a cross flow fan that is co-operated with the suction machine.

12. The oblique single air curtain range hood as claimed in claim 6 or 7 further including a blower that is in communication with the elongate air blow slot and co-operated with the suction machine.

13. The oblique single air curtain range hood as claimed in claim 6 or 7 further including an oil collection device that is in detachable connection with the elongate suction opening of the suction device.

14. The oblique single air curtain range hood as claimed in claim 13, wherein the oil collection device is a rectangular box with an opening on the top thereof and includes a base board from which a first side panel, a first upright board, a second upright board, and a second side panel extend upward, where a filter is provided on the base board, a first space is defined between the first side panel, the first upright board, and the base board while a second space is defined between the second side panel, the second upright board, and the base board, and the first and second side panels are engaged with outside of the elongate suction opening so that the oil on the wall inside the elongate suction opening drips into the first and second spaces.

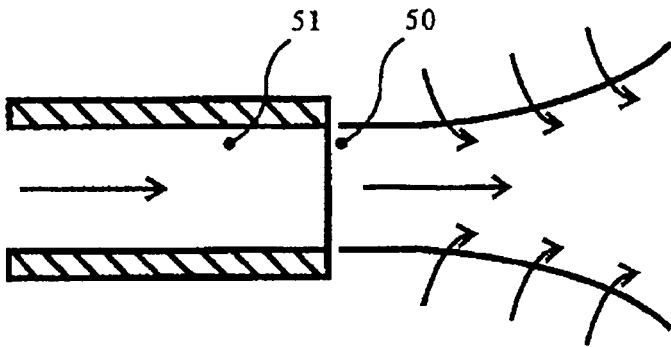

Fig.1A

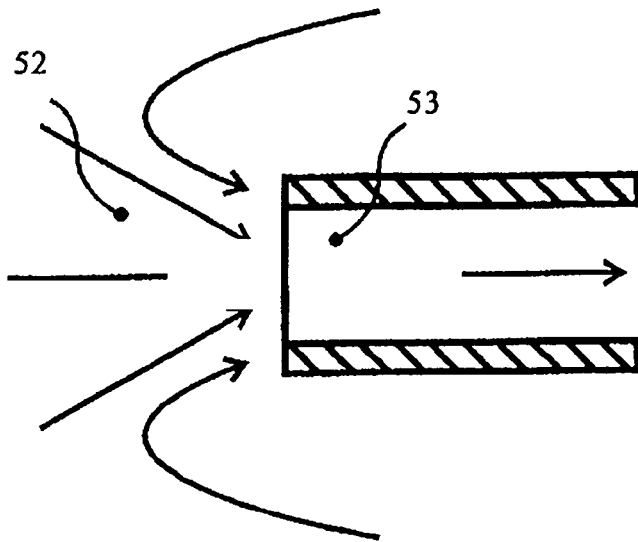

Fig.1B

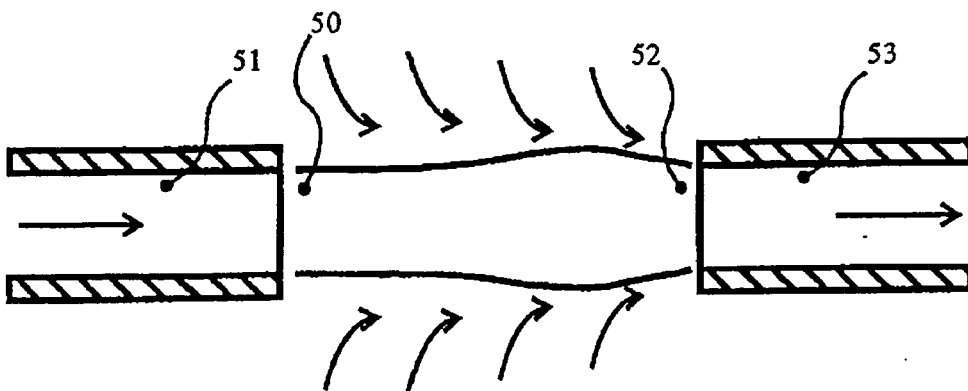

Fig.1C

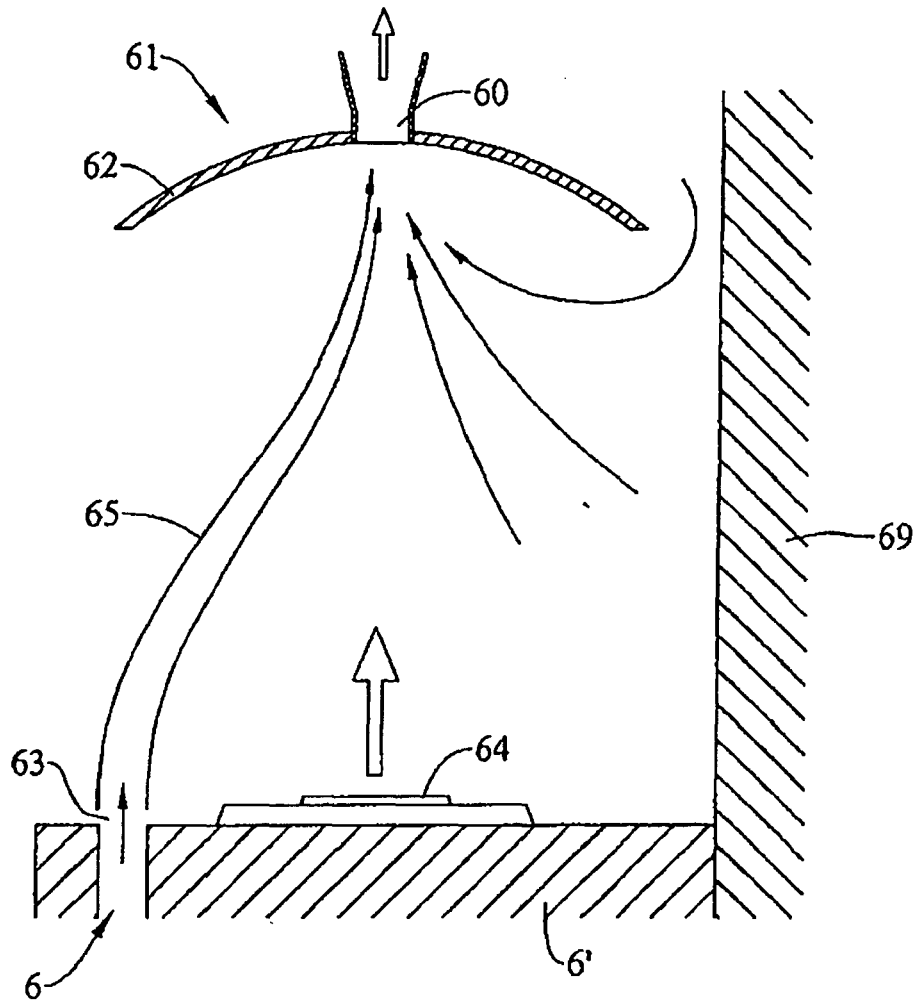

Fig. 2

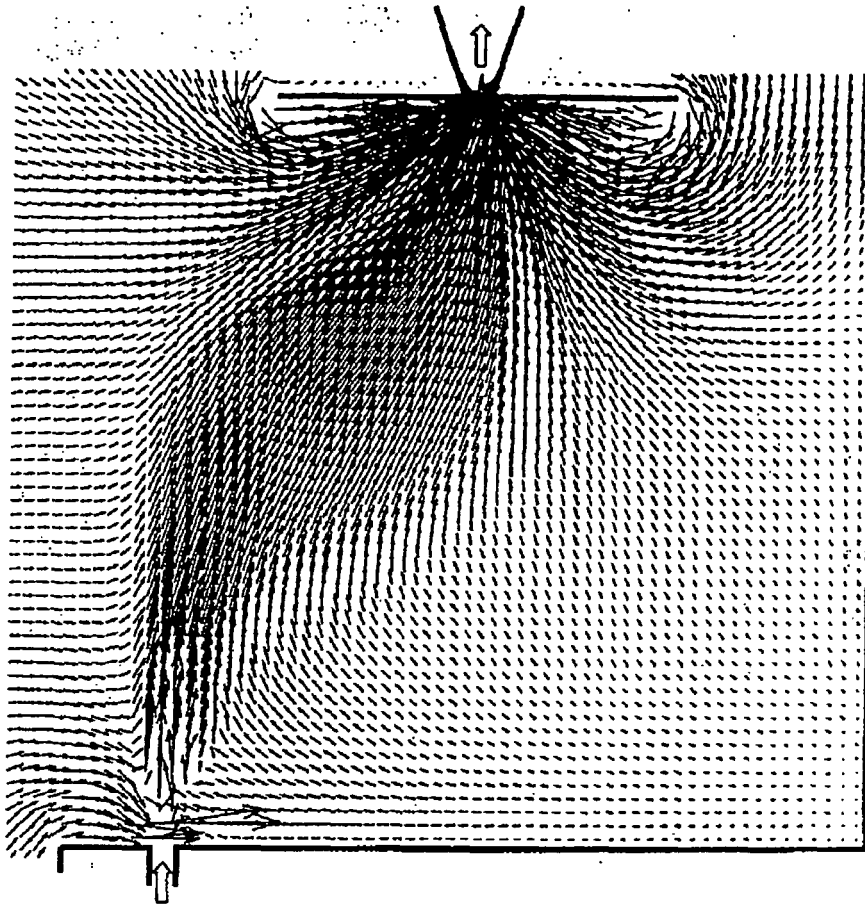

Fig.3

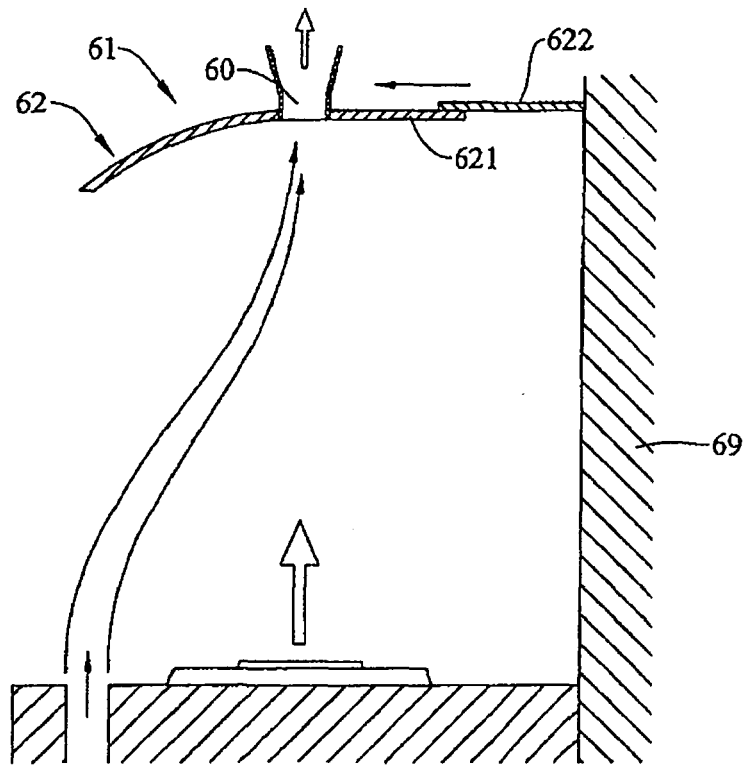

Fig.4

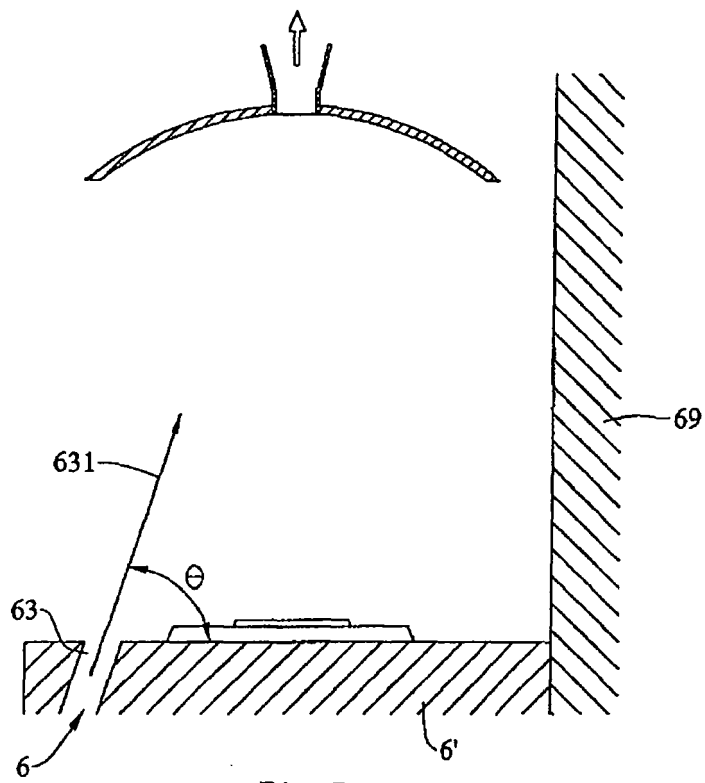

Fig. 5

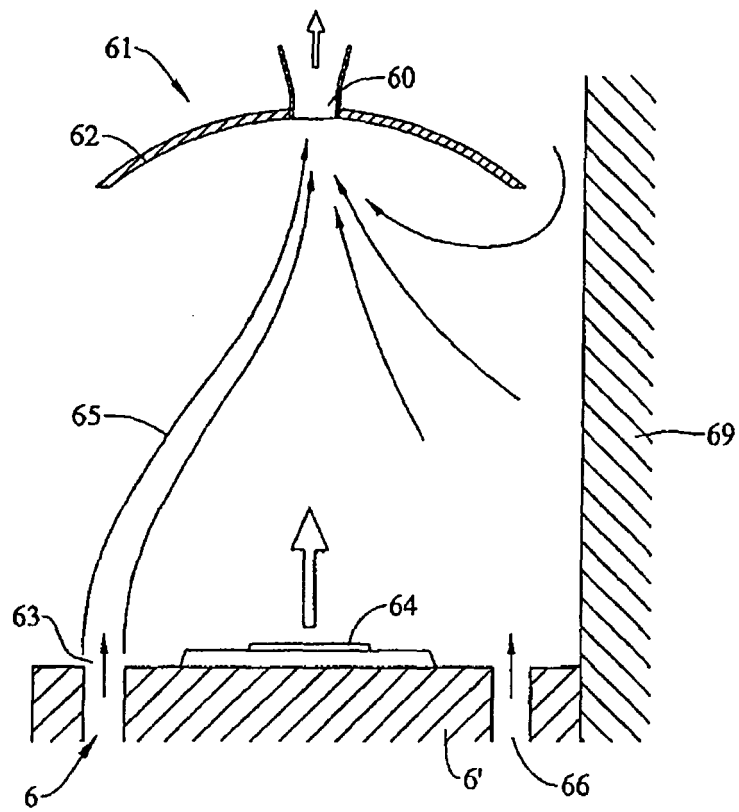

Fig. 6

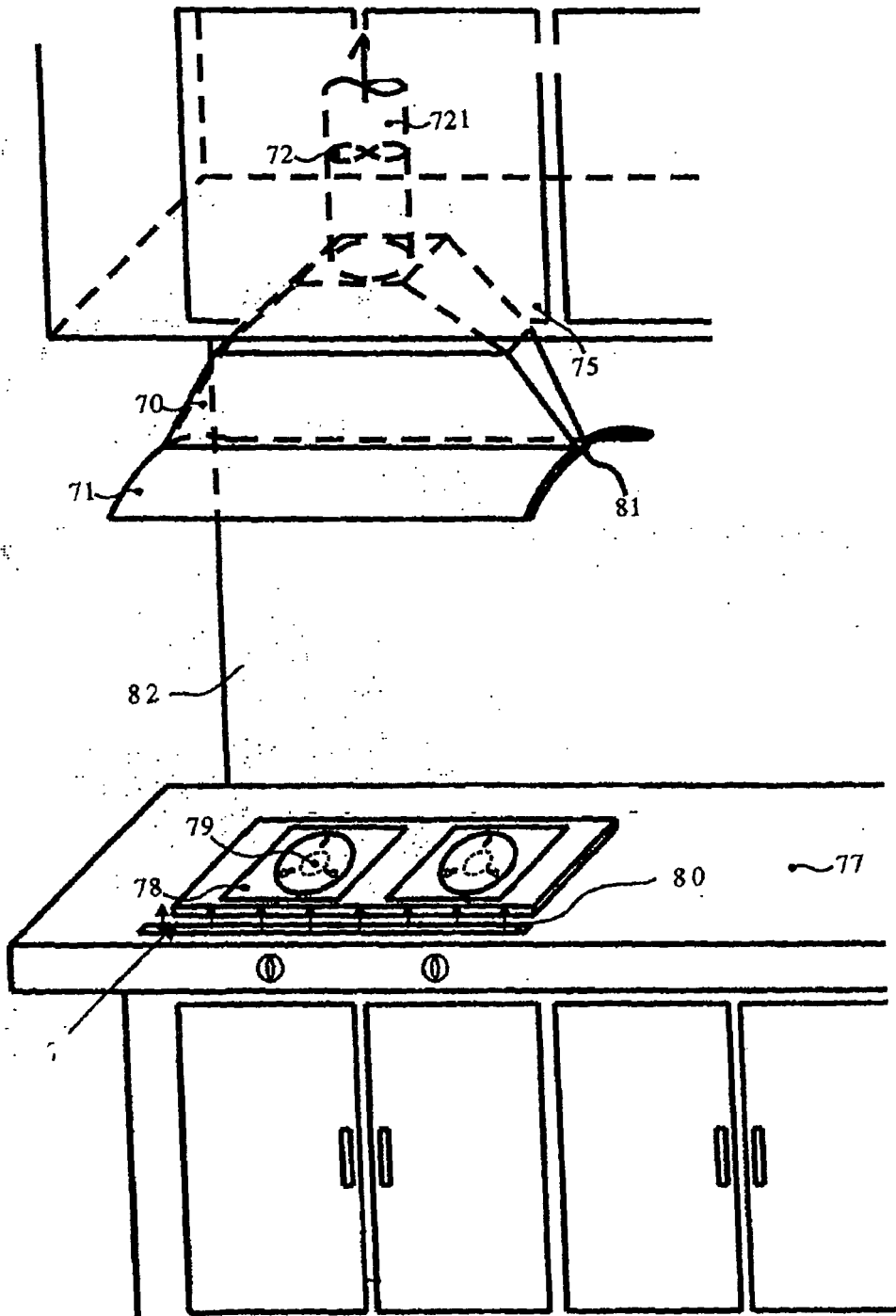

Fig.7

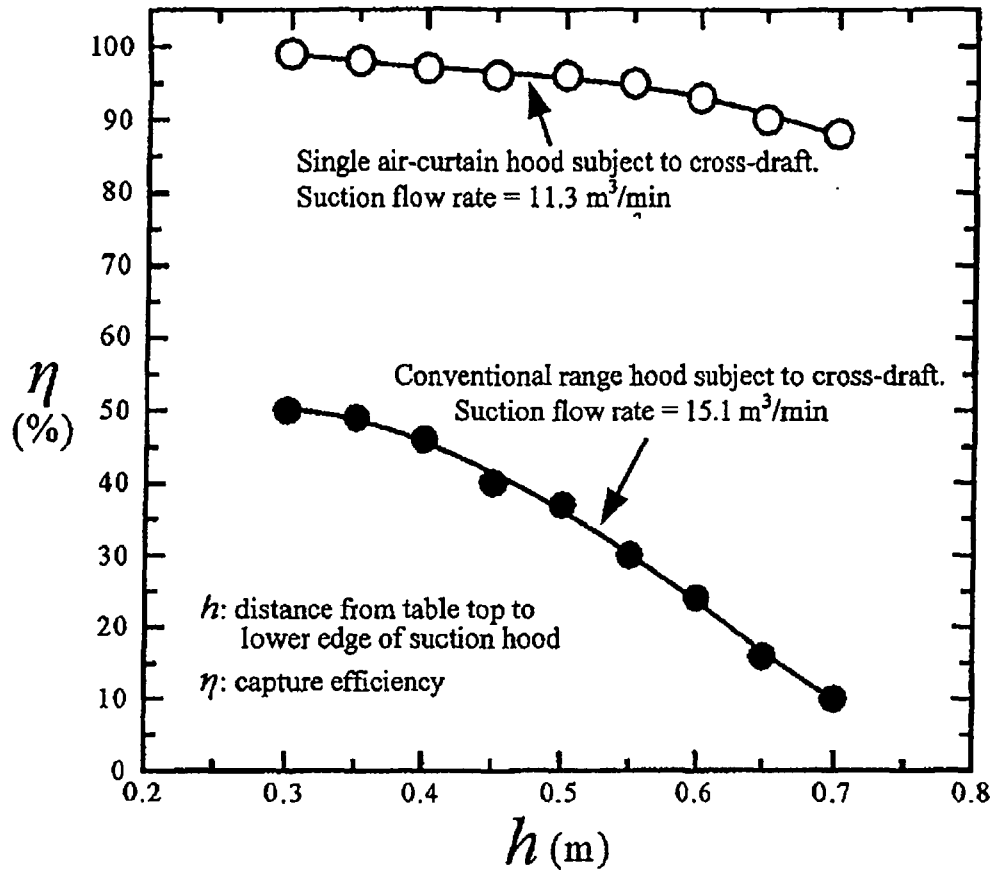

Fig. 8

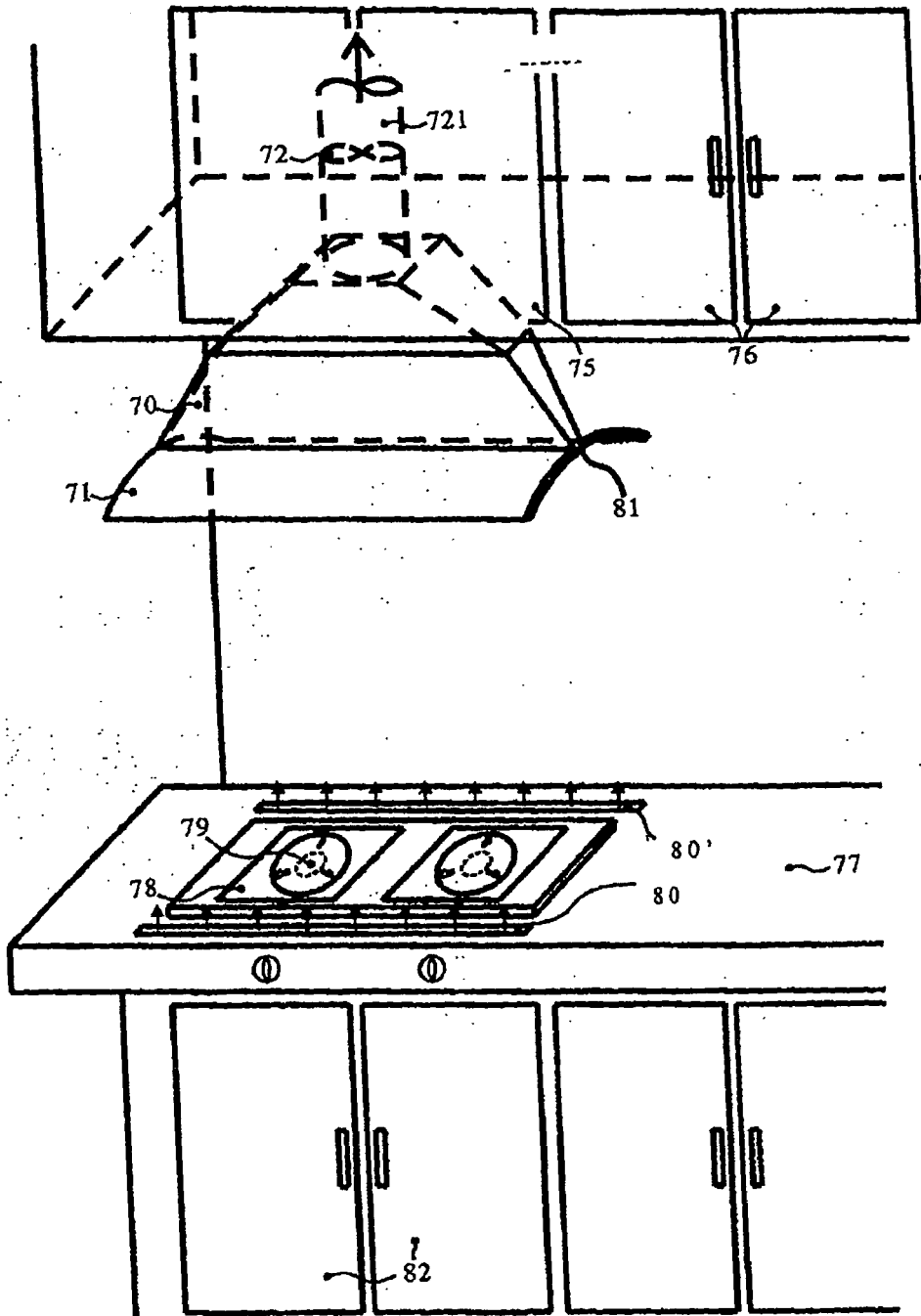

Fig.9

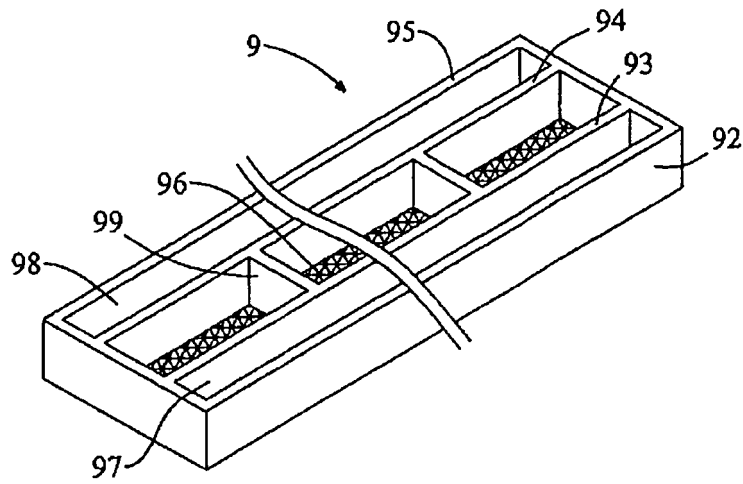

Fig. 10

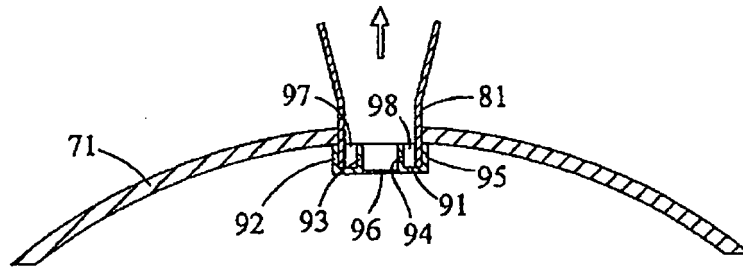

Fig. 11

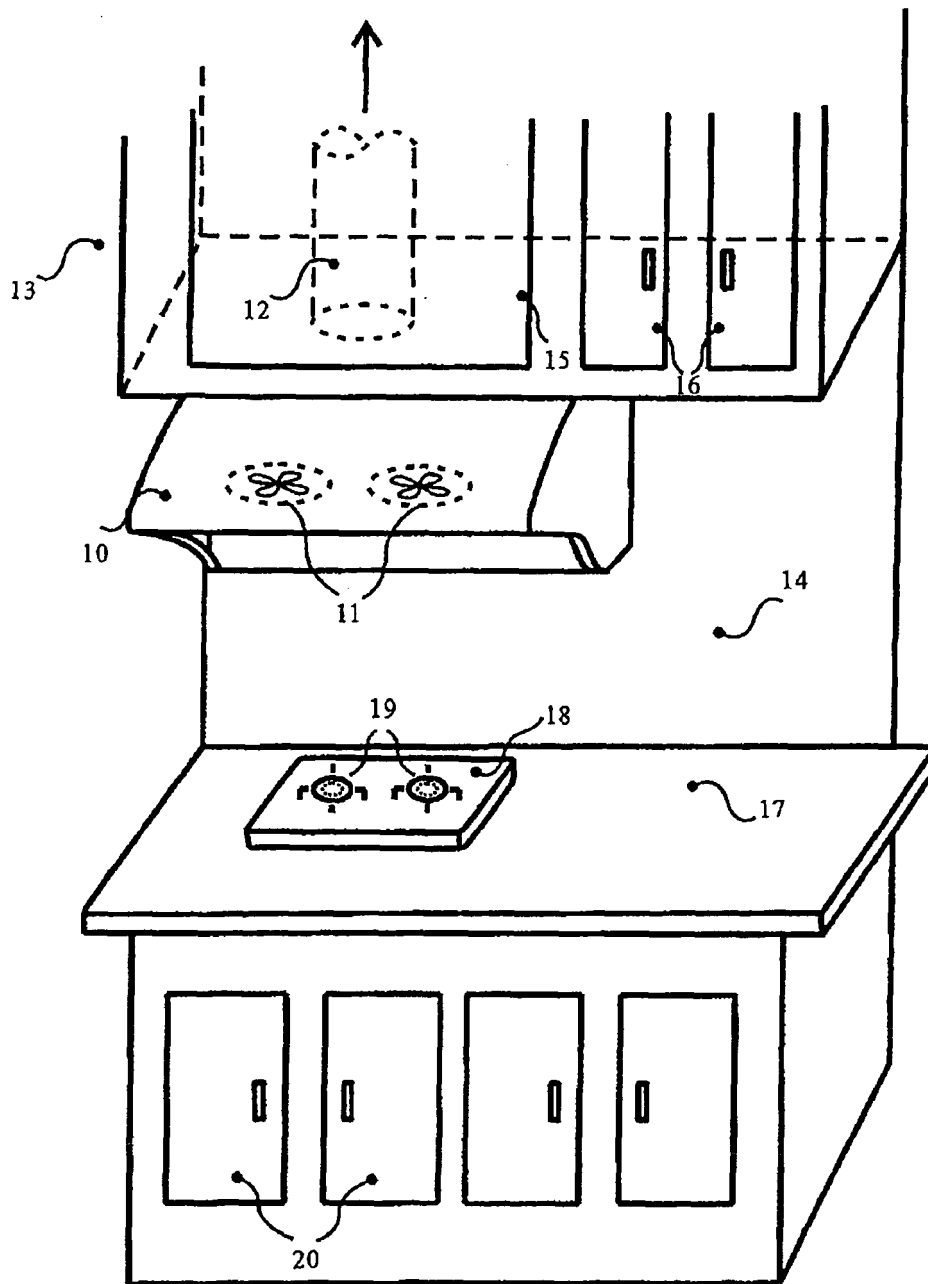

Fig.12(Prior Art)

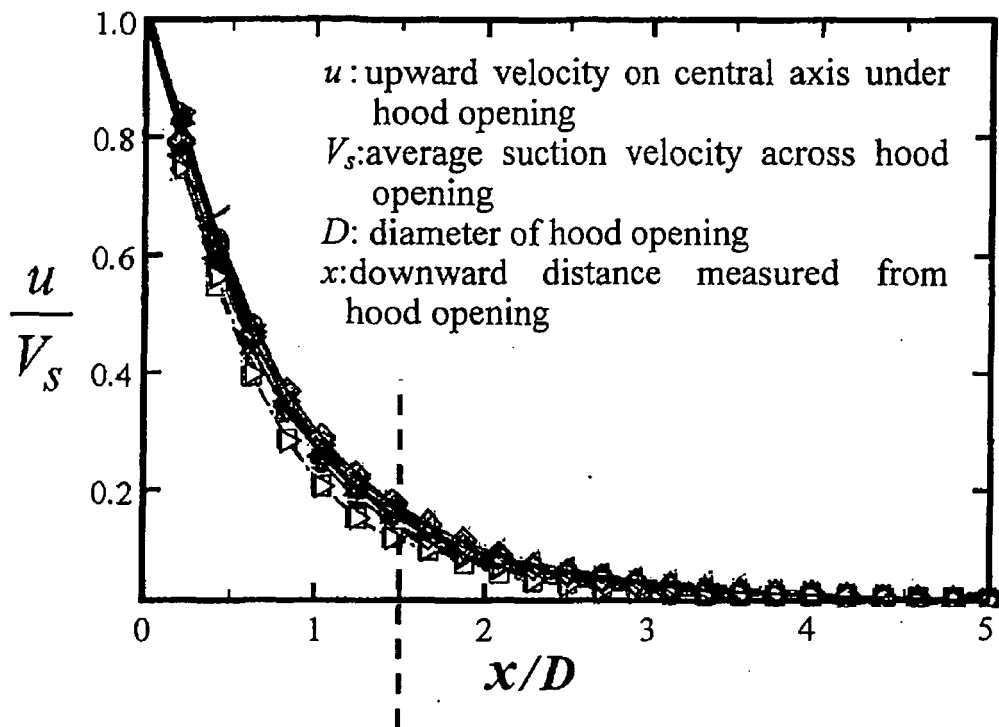

Fig.13(Prior Art)

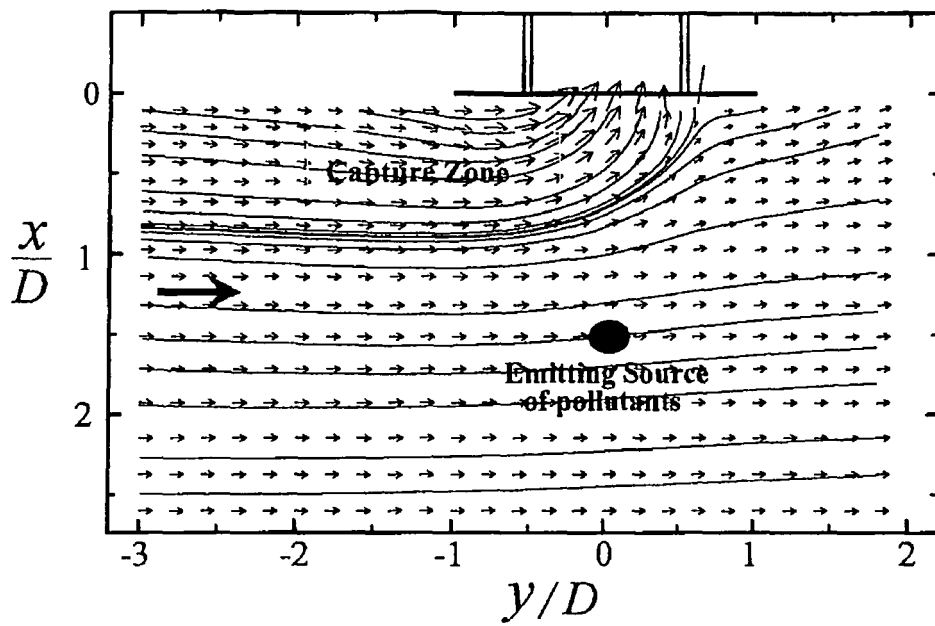

Fig.14(Prior Art)

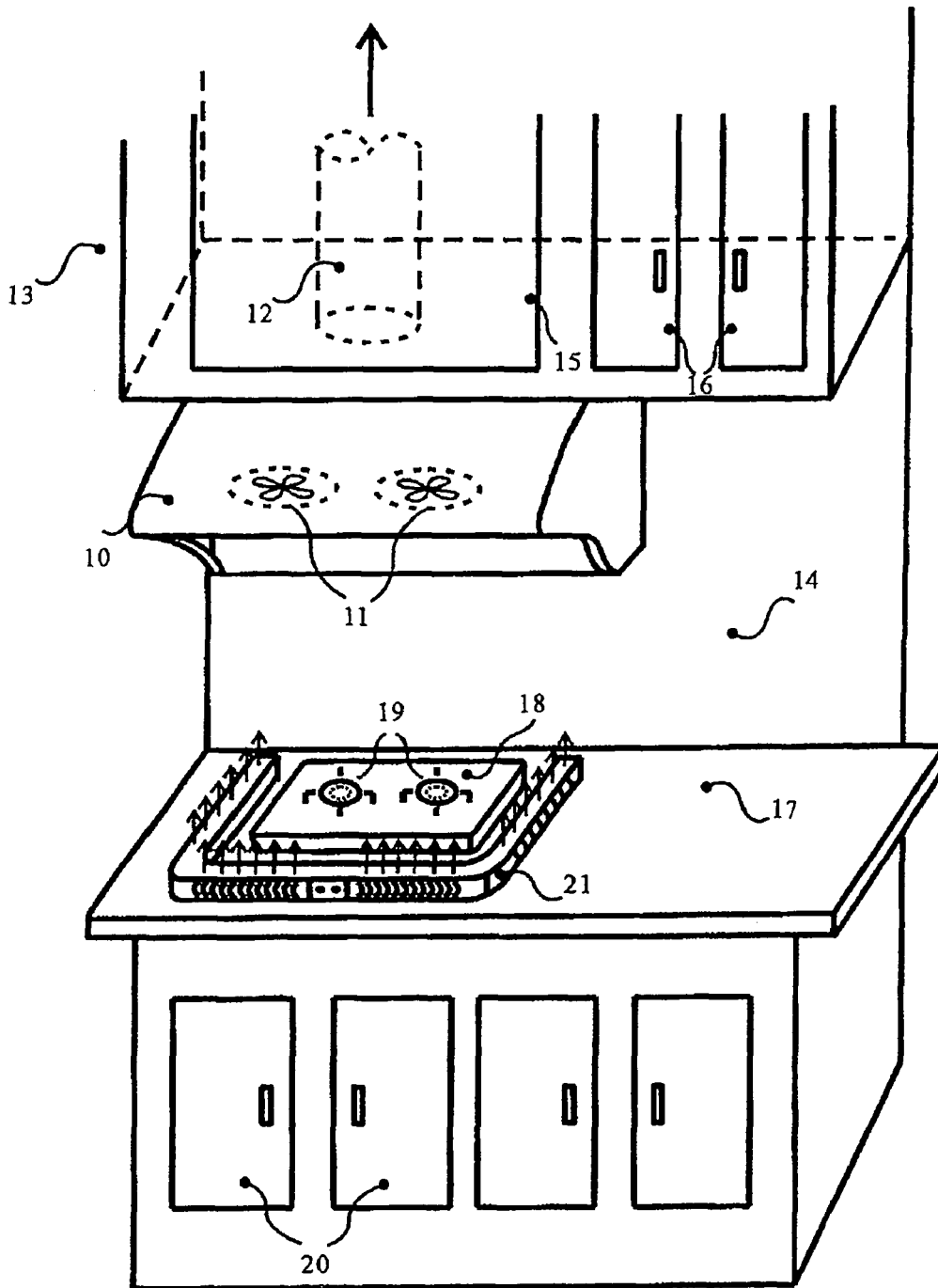

Fig.15(Prior Art)



EUROPEAN SEARCH REPORT

Application Number
EP 08 16 6293

DOCUMENTS CONSIDERED TO BE RELEVANT			
Category	Citation of document with indication, where appropriate, of relevant passages	Relevant to claim	CLASSIFICATION OF THE APPLICATION (IPC)
X	FR 2 506 432 A (NOE JACQUES [FR]) 26 November 1982 (1982-11-26)	1-3	INV. F24C15/20
Y	* pages 3-4; figures 1-3 *	4-14	
Y	DE 10 2005 002156 A1 (BSH BOSCH SIEMENS HAUSGERAETE [DE]) 20 July 2006 (2006-07-20) * figures 1-4 *	4	
Y	EP 1 696 180 A (WALDNER LABOR UND SCHULEINRICH [DE]) 30 August 2006 (2006-08-30) * pages 2-4; figures 1-8 *	5	
A		10	
Y	WO 98/22755 A (KIM BYONG DUK [KR]) 28 May 1998 (1998-05-28) * figure 3 *	6-14	
A	US 2004/123860 A1 (LIN JEROME [TW]) 1 July 2004 (2004-07-01) * figures 1,2 *	11	
A	US 2003/056784 A1 (YEUNG PETER [CA]) 27 March 2003 (2003-03-27) * paragraphs [0048], [0050] - [0053]; figures 1-3 *	13	
A	US 4 500 331 A (CHENG CHUNG-TSUNG [US]) 19 February 1985 (1985-02-19) * figures 1-3 *	14	
X	DE 202 05 642 U1 (MAIER MAX [DE]) 25 July 2002 (2002-07-25) * the whole document *	1,2, 11-13	
A	US 6 267 112 B1 (CHIANG PI TANG [TW]) 31 July 2001 (2001-07-31) * column 2; figures 1-7 *	14	
-/--			
The present search report has been drawn up for all claims			
Place of search Munich		Date of completion of the search 28 May 2009	Examiner Blot, Pierre-Edouard
CATEGORY OF CITED DOCUMENTS X : particularly relevant if taken alone Y : particularly relevant if combined with another document of the same category A : technological background O : non-written disclosure P : intermediate document		T : theory or principle underlying the invention E : earlier patent document, but published on, or after the filing date D : document cited in the application L : document cited for other reasons & : member of the same patent family, corresponding document	

1
EPO FORM 1503 03.82 (POAC01)



EUROPEAN SEARCH REPORT

Application Number
EP 08 16 6293

DOCUMENTS CONSIDERED TO BE RELEVANT			
Category	Citation of document with indication, where appropriate, of relevant passages	Relevant to claim	CLASSIFICATION OF THE APPLICATION (IPC)
A	US 2007/256680 A1 (CHIANG CHI-HSIUNG [TW] ET AL) 8 November 2007 (2007-11-08) * paragraph [0025]; figures 1-5 * -----	14	
X	NL 7 216 603 A (COMETAL, S.A. VOLGENS FRANS RECHT, TE CHATEAU-GONTIER FRANKRIJK) 12 June 1973 (1973-06-12) * figures 1-8 * -----	1	
			TECHNICAL FIELDS SEARCHED (IPC)
The present search report has been drawn up for all claims			
Place of search Munich		Date of completion of the search 28 May 2009	Examiner Blot, Pierre-Edouard
CATEGORY OF CITED DOCUMENTS X : particularly relevant if taken alone Y : particularly relevant if combined with another document of the same category A : technological background O : non-written disclosure P : intermediate document		T : theory or principle underlying the invention E : earlier patent document, but published on, or after the filing date D : document cited in the application L : document cited for other reasons & : member of the same patent family, corresponding document	

1
EPO FORM 1503 03.02 (P04C01)

**ANNEX TO THE EUROPEAN SEARCH REPORT
ON EUROPEAN PATENT APPLICATION NO.**

EP 08 16 6293

This annex lists the patent family members relating to the patent documents cited in the above-mentioned European search report. The members are as contained in the European Patent Office EDP file on
The European Patent Office is in no way liable for these particulars which are merely given for the purpose of information.

28-05-2009

Patent document cited in search report	Publication date	Patent family member(s)	Publication date
FR 2506432 A	26-11-1982	NONE	
DE 102005002156 A1	20-07-2006	NONE	
EP 1696180 A	30-08-2006	DE 102005008800 A1	31-08-2006
WO 9822755 A	28-05-1998	AU 7656496 A	10-06-1998
US 2004123860 A1	01-07-2004	GB 2398865 A	01-09-2004
US 2003056784 A1	27-03-2003	CA 2365790 A1	24-03-2003
US 4500331 A	19-02-1985	NONE	
DE 20205642 U1	25-07-2002	NONE	
US 6267112 B1	31-07-2001	NONE	
US 2007256680 A1	08-11-2007	NONE	
NL 7216603 A	12-06-1973	BE 792270 A1	30-03-1973
		IT 975965 B	10-08-1974

EPO FORM P0459

For more details about this annex : see Official Journal of the European Patent Office, No. 12/82