

F. WHITCOMB.

3 Sheets—Sheet 2.

Brick Machine.

No. 103,805.

Patented May 31, 1870.

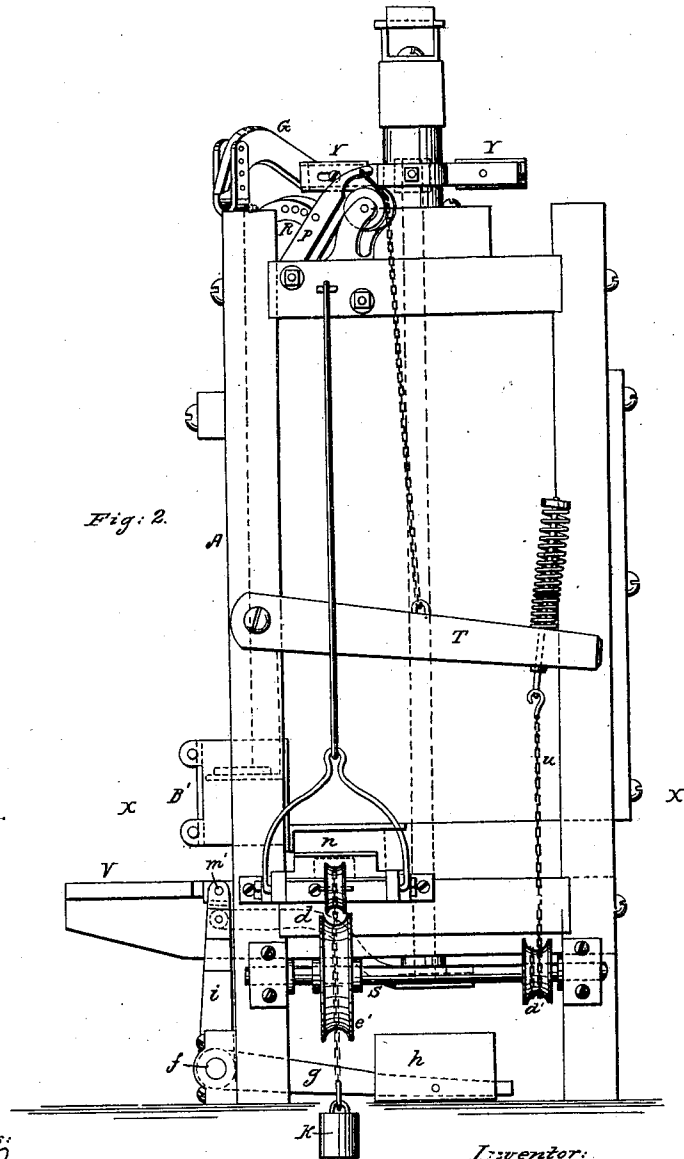

Fig. 2.

Witnesses:
H. H. Deibel.
F. W. Wolf.

Inventor:
Franklin Whitcomb.

F. WHITCOMB.
Brick Machine.

No. 103,805.

Patented May 31, 1870.

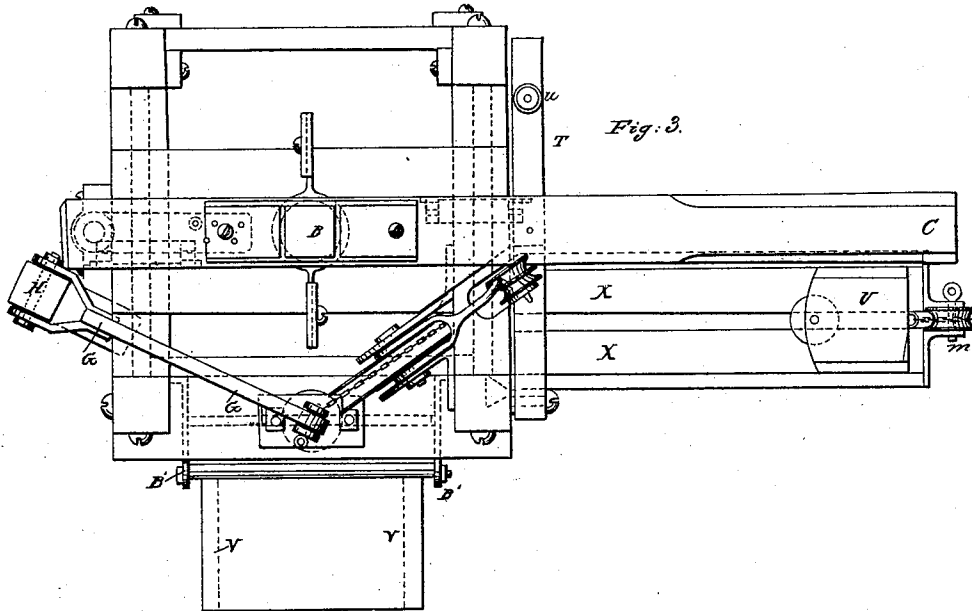

Fig. 3.

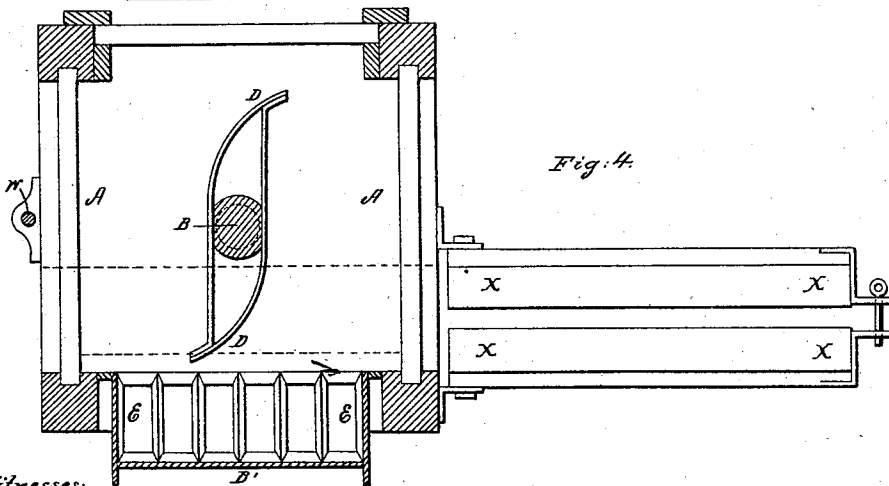

Fig. 4.

Witnesses:

Wm. H. Deibel.
J. W. Wolf.

Inventor:

Franklin Whitcomb.

United States Patent Office.

FRANKLIN WHITCOMB, OF CHICAGO, ILLINOIS.

Letters Patent No. 103,805, dated May 31, 1870.

IMPROVED BRICK-MACHINE.

The Schedule referred to in these Letters Patent and making part of the same.

To all whom it may concern:

Be it known that I, FRANKLIN WHITCOMB, of Chicago, in the county of Cook and State of Illinois, have invented certain Improvements in Brick-Machines, of which the following is a specification, reference being had to the accompanying drawing.

My invention relates to that class of machines which consists of a pug-mill, having a box or chamber on one side, into which the clay is fed, and from thence forced by a plunger down into the mold which is placed under said box or chamber; and

It consists is a novel arrangement of mechanism for operating the plunger, and also in certain devices for automatically feeding the molds into, and delivering them from the machine, all as hereinafter described.

Figure 1 is a front elevation of my machine.

Figure 2, a side elevation of the same.

Figure 3, a top plan view, and

Figure 4, a horizontal section of the machine, taken off the line *x-x* of fig. 1.

I first construct a strong square box or body, A, and support it upon suitable legs or frame-work, and mount within it an upright shaft, B, provided with oblique mixing-blades and curved horizontal arms D D, for forcing the clay into the receiver, and having a sweep, C, secured to its upper end, as shown in figs. 1, 2, and 3.

To the front side of the body A I secure a rectangular box or receiver, B', communicating by an opening in its side with the interior of body A, and, in suitable bearings upon the frame, I mount a vertical shaft, K, bearing on its lower end a plunger or piston, M, which fits closely within the receiver B', as shown in figs. 1 and 3.

To one side of the body I secure a post, H, and to this post pivot one end of a curved lever, G, the opposite end of which rests upon an adjustable pin or roller in the upper forked end of the shaft or rod K, and to the under side of the sweep C, on opposite sides of the posts B, I attach two rollers, F, which, as the sweep revolves, are carried over the lever G, and thus the lever depressed and the plunger forced downward, this depression of the plunger occurring twice at each revolution of the sweep.

Below the body I form a bed or platform, V, to support the molds when presented to the machine, and upon this bed I mount a sliding frame, *l*, which serves to feed the molds forward under the receiver B', the molds being introduced from the side of the machine onto the bed V in rear of the receiver, as hereinafter more fully described.

This frame *l* is operated by two rods, *a*', pivoted to its sides, and connected at their front ends by trunnion-nuts to arms *i* of a rock-shaft, *f*, which latter is mounted across the front of the frame below the bed or table V.

The rock-shaft *f* is also provided with two more arms, *g* and *e*, the former provided with a weight, *h*, and the latter connected by a link, *d*, with an arm, Z, attached to the lower end of a vertical rock-shaft, W, mounted on the side of the frame, as shown in figs. 1, 2, and 4.

To the upper end of the rock-shaft W I attach an arm, *b*, forked at its outer end, and provided with a pin or roller, *b'*, and to the shaft B I attach two extensible arms, Y, which, as the shaft B revolves, strike the roller *b'* in arm *b*, and cause the shaft W and its lower arm Z to vibrate, and thus, through the mediums of link *d* and arm *e*, operate the horizontal rock-shaft *f* and its arms *i*, and cause the frame *l* to move forward.

As soon as the arm *y* has passed the arm *b*, the weight *h* will reverse the motion of the parts, and carry the frame *l* back to its original position, preparatory to the insertion of another mold-frame in front of it.

The roller *b'* and the arms *y* are made adjustable, so as, through the shaft W, to adjust and time the movements of the slide *l* as required.

On the upper front side of the body I mount a segmental pulley, R, which is connected by a chain, *r*, with the shaft K, so that, by turning the pulley, the said shaft and its plunger M may be raised; and, on the same center with the pulley, I mount a forked arm, P, embracing it, and also provide the pulley with a series of holes, and the arm with one hole, so that, by means of a pin, the pulley and the arm may be secured together in different relative positions, as shown in figs. 1, 2, and 3.

To the side of the machine I make an opening, *n*', as shown in figs. 1 and 2, through which to insert the empty mold-frame, and opposite this opening I secure a horizontal slotted frame, X, having a sliding head or dog, U, mounted upon it, and held at the outer end of the frame by a weighted chain, passing over a pulley, *m*, as shown in figs. 1 and 3.

Across the side of the main frame, below the frame X, I mount a shaft, S, bearing a large pulley, *e*, and at the opposite end a smaller pulley, *d*, and I connect the former of these pulleys, by a chain, *g*, with the sliding head U, so that, by turning said shaft, the chain will be wound upon pulley *e*, and the head U be drawn toward the opening *n*', and thus, a mold-frame placed on frame X, in front of the head U, be carried into the machine by the head.

To the side of the frame, above the frame X, I pivot one end of a lever, T, and connect its free end by a chain, *t*, passing over a fixed pulley, with the end of arm P, and also connect it by another chain, *u*, with the small pulley *d* of shaft S, so that the plunger-rod K, being forced down, the chain *r*, operating pulley R and arm P, will, through chains *t* and

u, and lever *T*, operate the shaft *S*, and cause the head *U* to push a mold frame, previously placed in front of it, into the machine.

Upon the release of the lever *G* from the roller *F*, the weight *k* will draw back the head *U*, and, in so doing, will reverse the motion of the parts and cause the pulley *R* to raise the plunger.

The machine, thus constructed and arranged, is set in motion by turning the sweep, and it operates as follows:

The clay, partially mixed and tempered, is fed into box *A*, where it is thoroughly tempered by the oblique blades of shaft *B*, and forced downward until it reaches the arms *D*, when they force it out into the receiver *B'* below the plunger *M*, the arms *D* being so located as to fill the receiver while the plunger is elevated or is ascending.

As soon as the receiver is filled with clay, one of the rollers *F* bears upon the lever *G* and forces the plunger *M* downward, which presses the clay down into the empty mold previously placed below the receiver.

When the plunger-rod is forced down, the chain *r* is caused to operate the wheel *R* and its connections, and operates the head *U*, which carries another empty mold into the machine, ready to be fed under the receiver as soon as the first one is filled.

As soon as the roller passes from over the lever *G*, the weight *k* draws back the head *U*, and elevates the plunger *M*; should the parts bind, however, so that the weight will not operate them, the roller, as it travels in its course, will strike the arms *P* and force back pulley *R* so as to raise the plunger.

After the roller has passed the lever *G*, and the plunger has begun to rise, one of the arms *y* strikes the arm *b*, and, through the connections of the latter, causes the frame *l* to move forward the empty mold just shoved into the machine by head *U*, until it is brought below the receiver *B'*, the empty mold, as it moves forward, displacing the one filled by the previous descent of the plunger, and shoving it out onto the front of the bed *V*, from whence it is removed by the attendant and emptied.

Thus, as the sweep revolves, the rollers *F* operate the plunger and force new molds into the machine, the arms *y* deliver the empty molds to the filling mechanism and the filled molds from the machine, two molds being filled at each turn of the sweep.

The pin or roller in the upper end of the plunger-rod, upon which the lever *G* bears in operating said rod, I make adjustable, so that the piston may be car-

ried down a greater or lesser distance, as desired, according to the required pressure upon the clay forced into the mold.

The chain *u* I do not secure directly to the lever *T*, but to a rod passing through the same, and provided with a spiral spring on the upper side, as shown in figs. 1 and 2, so as to ease the various parts from the sudden strain that would otherwise be brought upon them in starting the machine, and also from the strain occasioned by suddenly stopping the weight *k* in its descent.

The arm *Z* and the front end of link *d* I provide with a series of holes, so that the points of connection between them and the other parts may be changed, as necessary.

Having thus described my invention,

What I claim, is—

1. The combination of the sweep *C*, lever *G*, segmental pulley *R*, with chain *r*, and forked arm *P*, when constructed and arranged substantially as herein described, for operating the plunger for filling the molds, as set forth.

2. In combination with sweep *C*, pulley *R*, with chain *r* and arm *P*, chain *t*, lever *T*, chain *u*, shaft *S* with pulleys *e* and *d'*, chains *q* and *l*, weight *h*, and sliding head *U*, when constructed and arranged to operate substantially as herein described, for the purpose of carrying the empty molds automatically into the machine.

3. The combination of the sweep *C*, shaft *B* with arms *y*, rock-shaft *W* with arms *b* and *z*, rock-shaft *f* with arms *e*, *g*, and *i*, rods *a*, weight *h*, and sliding frame *l*, when constructed and arranged to operate substantially as herein described, for the purpose of moving the molds forward automatically, as set forth.

4. The slotted head of the plunger *K*, with pin and roller therein, for adjusting the lever *G*, in combination with the adjustable arm *P* and chain *r*, when constructed and arranged to operate as herein described, for the purpose of adjusting the vertical movements of the plunger, as set forth.

5. The adjustable arms *b* and *z* on the rock-shaft *W*, in combination with the adjustable arms *y* on the shaft *B*, with their connections, when constructed and arranged substantially as herein described, for the purpose of adjusting the movements of the sliding frame *l*, as set forth.

FRANKLIN WHITCOMB.

Witnesses:

WM. H. DENBEL,

F. W. WOLF.