

(No Model.)

W. H. HOVEY.
ALE OR BEER FAUCET.

No. 368,768.

Patented Aug. 23, 1887.

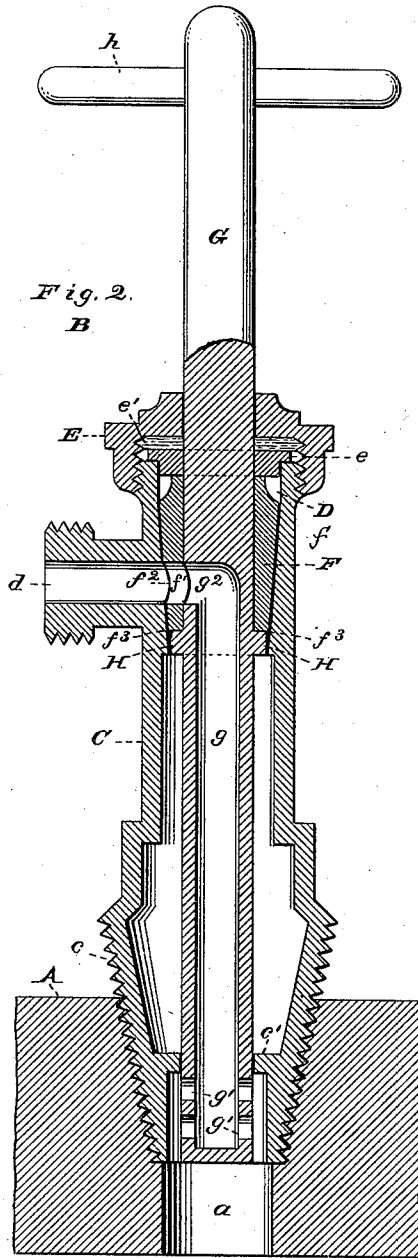
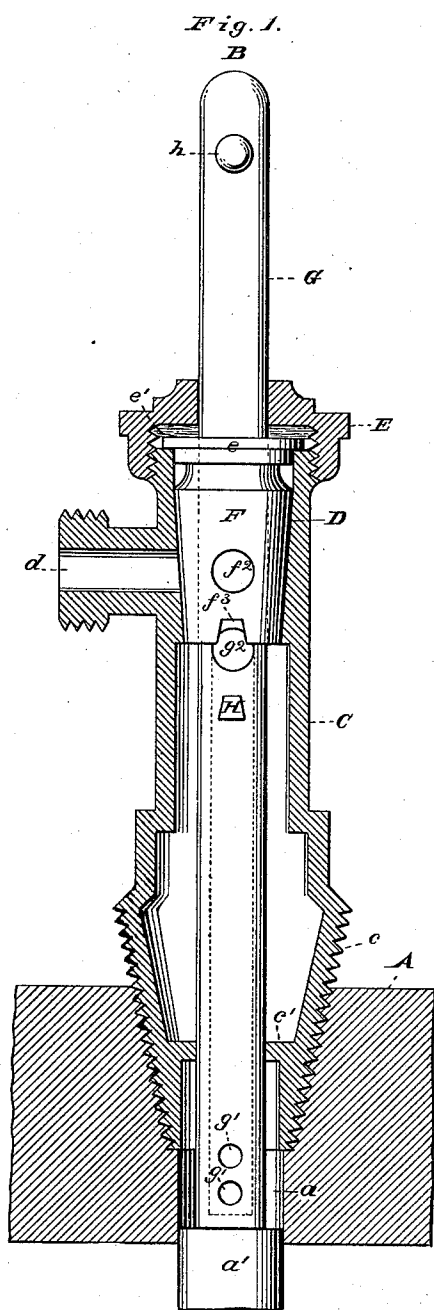

WITNESSES
Philip Massi.
Benj. Tugitt.

INVENTOR
Wm H. Hovey
by *E. W. Anderson*
his Attorney

UNITED STATES PATENT OFFICE.

WILLIAM H. HOVEY, OF SPRINGFIELD, MASSACHUSETTS, ASSIGNOR OF ONE-HALF TO SYLVESTER A. RYAN, OF SAME PLACE.

ALE OR BEER FAUCET.

SPECIFICATION forming part of Letters Patent No. 368,768, dated August 23, 1887.

Application filed March 25, 1887. Serial No. 232,398. (No model.)

To all whom it may concern:

Be it known that I, WILLIAM H. HOVEY, a citizen of the United States, residing at Springfield, in the county of Hampden and State of Massachusetts, have invented certain new and useful Improvements in Ale or Beer Faucets; and I do declare the following to be a full, clear, and exact description of the invention, such as will enable others skilled in the art to which it appertains to make and use the same, reference being had to the accompanying drawings, and to letters or figures of reference marked thereon, which form a part of this specification.

Figure 1 of the drawings is a representation of this invention, and shows a vertical section through the faucet-barrel and a portion of a barrel-head, and a side view of the conical plug and driving-rod. Fig. 2 is a vertical section through the whole device, and shows the plug and rod turned so as to open the faucet.

My invention relates to improvements in faucets for barrels or kegs containing malt liquors, such as beer and ale; and its objects are to permit the tapping of the keg or barrel to be performed quickly and readily and without any loss of the liquor by squirting out from the bung-hole around the inserted faucet, as often occurs with faucets of the usual construction, and to prevent leakage from the keg or barrel at the bung-hole around the faucet and at the discharge pipe or nipple of the latter. These objects I attain by means of the construction of the faucet barrel or cylinder and the combination of the same with other parts of the device, as hereinafter described, and embraced in the claims hereto appended.

Referring to the drawings by letter, A designates a portion of the head of a beer keg or barrel having the bung-hole *a* closed by the ordinary plug or bung, *a'*, in the usual way.

B is the improved faucet, having the cylinder C, the inner or entrance end, *c*, of which is conical, shaped as shown, externally threaded, and provided near the extremity with the internal diaphragm, *c'*, provided with a central circular guide and bearing-opening for the driving-rod herein described. The cylinder near its outer end is provided with a chamber, D, tapering slightly outward, and from

a proper point of said chamber the discharge tube or nozzle *d* runs outward. The outer end of the cylinder C is externally threaded for the engagement of a screw-cap, E, having in its base a central circular guide and bearing-opening for the driving-rod before mentioned.

e is a washer, and *e'* proper packing between the end of the cylinder and the cap to make the joint between them properly tight.

F is a conical plug fitting snugly and capable of turning in the chamber D, and provided with a central longitudinal opening, *f*, through which the driving-rod slides. The said plug is provided with an opening, *f'*, at right angles to and communicating with its central opening, *f*, and having its orifice *f''* in position to register with the discharge-nozzle *d*. *f'''* is a notch in one side of the inner end of the plug F, for a purpose hereinafter explained.

G is the cylindrical driving-rod passing through the opening in the cap, the plug F, and the diaphragm *c'*, as described, and provided with the central longitudinal chamber, *g*, having near its inner end the inlet-openings *g'*, *g'*, and at its upper end with the outlet-opening *g''*.

H is a projection on the outside of the driving-rod, of proper size and shape to enter and fit the notch *f'''* in the end of the plug F. The driving-rod has a suitable handle, *h*, on its outer end, and when drawn outward thereby until the projection H enters the notch *f'''* the opening *g''* registers with the opening *f''* in the plug. The driving-rod then can be pulled no farther outward, and when rotated by its handles the plug will rotate with it.

The method of using the device is as follows: The bung *a'*, being driven slightly in the tapped or threaded end of the cylinder C, will take hold in the outer end of the bung-hole *a*. Then screw the said end in the hole until secure therein. A few taps with a mallet on the outer end of the driving-rod will then force the bung in the barrel, and the said rod can be pushed in till the liquid will flow on through the openings *g'* and fill the chamber *g*, and also the interior of the cylinder, when the end of the driving-rod is pulled outward beyond the diaphragm *c'*. When it is intended to draw off beer, the driving-rod is pulled outward till the projection H engages in the notch *f'''*,

and the said rod is turned, turning the plug F with it, till openings g^2 and f' register with the discharge tube or nozzle d . The beer will then flow through the chamber g and out said discharge-nozzle till the driving-rod and cylinder are turned to cut off the communication with the nozzle.

It is evident that the screw end of the cylinder will hold secure in the head of the barrel, and that no leakage can take place around it. It is also evident that by cutting off the communication between the discharge-nozzle and the opening f' and the communication of the latter with the opening g^2 by pushing in the driving-rod no leakage can take place at the nozzle.

Having described my invention, I claim—

1. In a faucet, the combination, with the cylinder having the conical inner end to engage in the bung-hole of a barrel, and a side discharge-opening, of a valve regulating said opening, and a chambered bung-driving valve-stem sliding and turning in guide-bearings of said cylinder, and having inlet and outlet openings at or near the end of the cylinder to allow an inflow into its chamber, substantially as specified.

2. In a faucet, the combination of the cylinder provided with the conical externally-threaded inner end, the conical chamber near its outer end, and the outlet-nozzle communicating with said chamber, the screw cap on the outer end of said cylinder, the hollow conical plug fitting in the chamber in the cylinder

and provided with a transverse opening extending from its central opening and in position to register with the discharge-opening from the cylinder, the driving-rod passing through guide-openings in the cap of the cylinder and in a diaphragm in the lower end of the same, and provided with a longitudinal chamber having outlet-openings at its lower end, and an outlet-opening at its outer end, and means, substantially as described, whereby the plug is made to rotate with the driving-rod when the outlet-openings in the rod, the plug, and the cylinder are in position to register with each other, substantially as specified.

3. The herein-described faucet, consisting of the cylinder C, having the conical threaded end c , provided with the diaphragm c' , the tapered chamber D and discharge-tube d , the screw-cap E, engaging the outer end of said cylinder, the conical cap F, fitting in the chamber D, and provided with the longitudinal opening f , outlet-opening f' , and notch f^3 , and the cylindrical driving-rod provided with the projection H and longitudinal chamber g , having the inlet-openings g' and outlet-opening g^2 , all constructed and arranged substantially as specified.

In testimony whereof I affix my signature in presence of two witnesses.

WM. H. HOVEY.

Witnesses:

H. D. VAN RENSSELAER,
E. B. SAGE.