

**(12) STANDARD PATENT**  
**(19) AUSTRALIAN PATENT OFFICE**

(11) Application No. **AU 2021364397 B2**

(54) Title  
**FORCED AIR COOLING FOR DISPLAY ASSEMBLIES**

(51) International Patent Classification(s)  
**G02F 1/133** (2006.01)      **B60L 53/16** (2019.01)

(21) Application No: **2021364397**      (22) Date of Filing: **2021.10.22**

(87) WIPO No: **WO22/087488**

(30) Priority Data

(31) Number	(32) Date	(33) Country
<b>17/078,861</b>	<b>2020.10.23</b>	<b>US</b>

(43) Publication Date: **2022.04.28**

(44) Accepted Journal Date: **2024.06.13**

(71) Applicant(s)  
**MANUFACTURING RESOURCES INTERNATIONAL, INC.**

(72) Inventor(s)  
**DUNN, William; DIAZ, Marcos; MOREAU, Alex**

(74) Agent / Attorney  
**Spruson & Ferguson, GPO Box 3898, Sydney, NSW, 2001, AU**

(56) Related Art  
**WO 2014/195560 A1**



(51) International Patent Classification:

G02F 1/133 (2006.01) B60L 53/16 (2006.01)

(21) International Application Number:

PCT/US2021/056353

(22) International Filing Date:

22 October 2021 (22.10.2021)

(25) Filing Language:

English

(26) Publication Language:

English

(30) Priority Data:

17/078,861 23 October 2020 (23.10.2020) US

(71) Applicant: **MANUFACTURING RESOURCES INTERNATIONAL, INC.** [US/US]; 6415 Shiloh Road East, Alpharetta, GA 30005 (US).

(72) Inventors: **DUNN, William**; 6415 Shiloh Road East, Alpharetta, GA 30005 (US). **DIAZ, Marcos**; 6415 Shiloh Road East, Alpharetta, GA 30005 (US). **MOREAU, Alex**; 6415 Shiloh Road East, Alpharetta, GA 30005 (US).

(74) Agent: **SMITH, Adam, J.** et al.; Standley Law Group LLP, 6300 Riverside Drive, Dublin, OH 43017 (US).

(81) Designated States (unless otherwise indicated, for every kind of national protection available): AE, AG, AL, AM, AO, AT, AU, AZ, BA, BB, BG, BH, BN, BR, BW, BY, BZ, CA, CH, CL, CN, CO, CR, CU, CZ, DE, DJ, DK, DM, DO,

DZ, EC, EE, EG, ES, FI, GB, GD, GE, GH, GM, GT, HN, HR, HU, ID, IL, IN, IR, IS, IT, JO, JP, KE, KG, KH, KN, KP, KR, KW, KZ, LA, LC, LK, LR, LS, LU, LY, MA, MD, ME, MG, MK, MN, MW, MX, MY, MZ, NA, NG, NI, NO, NZ, OM, PA, PE, PG, PH, PL, PT, QA, RO, RS, RU, RW, SA, SC, SD, SE, SG, SK, SL, ST, SV, SY, TH, TJ, TM, TN, TR, TT, TZ, UA, UG, US, UZ, VC, VN, WS, ZA, ZM, ZW.

(84) Designated States (unless otherwise indicated, for every kind of regional protection available): ARIPO (BW, GH, GM, KE, LR, LS, MW, MZ, NA, RW, SD, SL, ST, SZ, TZ, UG, ZM, ZW), Eurasian (AM, AZ, BY, KG, KZ, RU, TJ, TM), European (AL, AT, BE, BG, CH, CY, CZ, DE, DK, EE, ES, FI, FR, GB, GR, HR, HU, IE, IS, IT, LT, LU, LV, MC, MK, MT, NL, NO, PL, PT, RO, RS, SE, SI, SK, SM, TR), OAPI (BF, BJ, CF, CG, CI, CM, GA, GN, GQ, GW, KM, ML, MR, NE, SN, TD, TG).

Published:

- with international search report (Art. 21(3))
- before the expiration of the time limit for amending the claims and to be republished in the event of receipt of amendments (Rule 48.2(h))

(54) Title: FORCED AIR COOLING FOR DISPLAY ASSEMBLIES

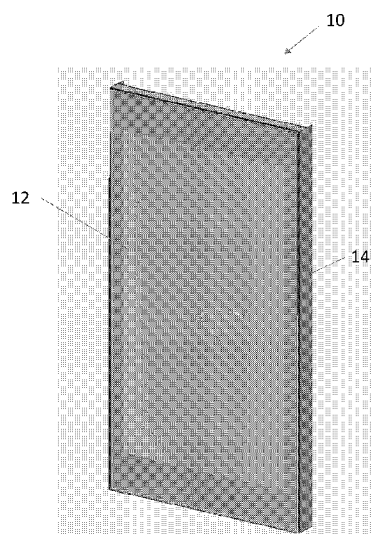

Figure 1

(57) Abstract: A display assembly with forced air cooling and integrated electric vehicle charging equipment includes a first and second side assembly connected to a structural frame, each including an electronic display subassembly located behind a cover. The electric vehicle charging equipment is connected to the structural frame between said first and second side assemblies in an at least partially recessed manner. Open or closed loops of air may be provided for cooling the first and second side assemblies and the electric vehicle charging equipment, which may all be connected to a common power source.



## **FORCED AIR COOLING FOR DISPLAY ASSEMBLIES**

### **CROSS-REFERENCE TO RELATED APPLICATIONS**

**[0001]** This application claims priority to U.S. Application No. 17/078,861 filed October 23, 2020, the disclosures of which are hereby incorporated by reference as if fully restated herein.

### **TECHNICAL FIELD**

**[0002]** Exemplary embodiments relate generally to systems and methods for forced air cooling of display assemblies, such as those incorporating electric vehicle charging equipment.

### **BACKGROUND AND SUMMARY OF THE INVENTION**

**[0002a]** It is an object of the present invention to substantially overcome or at least ameliorate one or more disadvantages of existing arrangements.

**[0002b]** In a first aspect, the present invention provides a display assembly with integrated electric vehicle charging equipment, said display assembly comprising: a structural frame; a first side assembly connected to a first side of said structural frame, said first side assembly comprising a first cover and a first electronic display subassembly located behind said first cover; a second side assembly connected to a second side of said structural frame, said second side assembly comprising a second cover and a second electronic display subassembly located behind said second cover; a recessed compartment extending inward to the display assembly between said first side assembly and said second side assembly; and said electric vehicle charging equipment, wherein said electric vehicle charging equipment is located between said first side assembly and said second side assembly; wherein a first portion of the electric vehicle charging equipment is provided within the recessed compartment, and a second portion of the electric vehicle charging equipment is provided interior to the structural frame.

**[0002c]** In a second aspect, the present invention provides a display assembly with integrated electric vehicle charging equipment and forced air cooling, said display assembly comprising: a frame; a first side assembly moveably connected to a first side of said frame and comprising: a first cover; a first electronic display layer located behind

said cover; and a first backlight located behind said first electronic display layer; a second side assembly moveably connected to a second side of said frame and comprising: a second cover; a second electronic display layer located behind said second cover; and a second backlight located behind said second electronic display layer; one or more intakes; one or more exhausts; one or more interior channels extending within said frame and between said first electronic display layer and said second electronic display layer; one or more open loop pathways comprising said one or more intakes, said one or more interior channels, and said one or more exhausts; one or more fans configured to move ambient air through said one or more open loop pathways when activated; a cavity positioned between said first and second side assemblies and housing at least some internal components of the electric vehicle charging equipment; a housing recessed from said frame to extend inward to protrude within said cavity, said housing accommodating at least some exterior components of said electric vehicle charging equipment when docked at the display assembly; and an additional storage area located below or between said first and second side assemblies for accommodating at least some other interior components of said electric vehicle charging equipment; wherein at least said first side assembly, said second side assembly, and said electric vehicle charging equipment are electrically connected to a common power supply.

**[0003]** The use of electronic displays for advertising in the out-of-home market has increased in popularity over recent years. Being located outdoors, such electronic displays are frequently exposed to harsh conditions, including but not limited to, solar loading, extreme temperatures, precipitation, moisture, contaminants, vandalism, wildlife, and the like. To protect the electronic displays and other components from such harsh conditions, it is known to place the electronic displays in fully or partially sealed housings. The harsh conditions and/or placement in such fully or partially sealed housings, may create a need to thermally manage the electronic displays. It is known to provide open and/or closed loop airflow pathways through such housings to control temperatures, thereby maintaining desirable operating conditions for the electronic displays and related components. It is known to provide back-to-back electronic displays with a common plenum, such as is provided in US Pat. No. 8,373,841 issued February 12, 2013, or a common heat exchanger, such as is provided in US Pat. No. 8,351,014 issued January 8, 2013.

**[0004]** Traditionally, tube axial fans are used to force such cooling through these open and/or closed loop airflow pathways, though other types of fans such as centrifugal fans have been used. What is needed is an electronic display assembly which utilizes centrifugal fans to provide forced air cooling.

**[0005]** Electronic display assemblies which utilize centrifugal fans to provide forced air cooling are provided. Such centrifugal fans may be utilized in one or more open loop airflow pathways, one or more closed loop airflow pathways, some combination thereof, or the like.

**[0006]** The use of such centrifugal fans may provide several advantages. For example, without limitation, the design of such centrifugal fans may require that air be turned essentially 90 degrees during normal operation. Corners may be provided along the open and/or closed loop airflow pathways of display assemblies which normally provide areas of airflow resistance and/or turbulence. When deployed in such display assemblies, the centrifugal fan may be placed to essentially turn the air the 90 degrees otherwise required to complete a loop or pass through the housing. The use and engineered placement of centrifugal fans may therefore form a natural part of the open or closed loop airflow pathways and may improve airflow efficiency around such corners.

**[0007]** Additionally, or alternatively, such centrifugal fans may facilitate even distribution of air upon discharge. This may improve evenness of cooling, distribution, and/or airflow. For example, without limitation, the centrifugal fans may be provided without certain common shrouding components to facilitate such distribution.

**[0008]** As another example, without limitation, the centrifugal fans may reduce noise emission and/or utilize less power relative to other types of fans such as tube axial fans. As yet another example, without limitation, the centrifugal fans may provide the same or higher mass airflow rates for air. The use of such centrifugal fans may, for example, without limitation, result in increased homogenization of air. Such homogenization may lead to more even cooling and better temperature control of such display assemblies and related components. This may result in a reduction of the number of fans and/or the operating speed of such fans.

**[0009]** It may be desirable to incorporate electric vehicle (“EV”) chargers into such display assemblies. Such EV chargers may be able to take advantage of established structural framework, power supplies, and/or thermal management capabilities of the display assemblies. Alternatively, or additionally, such display assemblies may be modified, such as structurally, electrically, or thermodynamically, to accommodate such EV chargers. In exemplary embodiments, advertisements, announcements, or entertaining images, to provide a few non-limiting examples, may be displayed at the subassemblies while electric vehicles are charged nearby.

**[0010]** Further features and advantages of the systems and methods disclosed herein, as well as the structure and operation of various aspects of the present disclosure, are described in detail below with reference to the accompanying figures.

### BRIEF DESCRIPTION OF THE DRAWINGS

- [0011] In addition to the features mentioned above, other aspects of the present invention will be readily apparent from the following descriptions of the drawings and exemplary embodiments, wherein like reference numerals across the several views refer to identical or equivalent features, and wherein:
- 5 [0012] **FIGURE 1** is a front perspective view of an exemplary display assembly in accordance with the present invention;
- [0013] **FIGURE 2** is a front view of the display assembly of figure 1;
- [0014] **FIGURE 3** is a rear perspective view of the display assembly of figure 1 with  
10 certain components removed to illustrate other, internal components;
- [0015] **FIGURE 4** is a rear perspective view of the display assembly of figure 3 with a rear cover removed to illustrate additional, internal components;
- [0016] **FIGURE 5** is a rear view of another exemplary embodiment of the display assembly of figure 4;
- 15 [0017] **FIGURE 6A** is a side sectional view of the display assembly of figure 1 taken along section line A-A of figure 2;
- [0018] **FIGURE 6B** is a side section view of the display assembly of figure 6A with an exemplary flow velocity profile demonstrating exemplary open loop airflow;
- [0019] **FIGURE 7A** is a top sectional view of the display assembly of figure 1 taken  
20 along section line B-B of figure 2;
- [0020] **FIGURE 7B** is a side section view of the display assembly of figure 7A with an exemplary flow velocity profile demonstrating exemplary closed loop airflow;
- [0021] **FIGURE 8** is a front perspective view of another exemplary display assembly in accordance with the present invention;
- 25 [0022] **FIGURE 9** is a front view of the display assembly of figure 8;
- [0023] **FIGURE 10A** is a side sectional view of the display assembly of figure 8 taken along section line C-C- of figure 9;
- [0024] **FIGURE 10B** is a detailed side section view of the display assembly of figure 10A taken from detail A of figure 10A with an exemplary flow velocity profile  
30 demonstrating exemplary open loop airflow;
- [0025] **FIGURE 11A** is a top sectional view of the display assembly of figure 8 taken along section line D-D of figure 9;
- [0026] **FIGURE 11B** is a side section view of the display assembly of figure 11A with an exemplary flow velocity profile demonstrating exemplary closed loop airflow;

[0027] **FIGURE 12** is a front perspective view of the display assembly of figure 8 with certain components removed to illustrate certain internal components;

[0028] **FIGURE 13** is a rear perspective view of the display assembly of figure 8 with certain components removed to illustrate certain internal components;

5 [0029] **FIGURE 14** is a detailed rear perspective view of the display assembly of figure 8 taken from detail A of figure 13 with an exemplary flow path profile for demonstrating exemplary closed loop airflow;

[0030] **FIGURE 15A** is a plan view of an exemplary electrical schematic for the display assembly of figures 1-14;

10 [0031] **FIGURE 15B** is a plan view of another exemplary electrical schematic for the display assembly of figures 1-14;

[0032] **FIGURE 15C** is a plan view of another exemplary electrical schematic for the display assembly of figures 1-14; and

[0033] **FIGURE 15D** is a plan view of another exemplary electrical schematic for  
15 the display assembly of figures 1-14.

#### **DETAILED DESCRIPTION OF EXEMPLARY EMBODIMENT(S)**

[0034] Various embodiments of the present invention will now be described in detail with reference to the accompanying drawings. In the following description, specific details such as detailed configuration and components are merely provided to assist the  
20 overall understanding of these embodiments of the present invention. Therefore, it should be apparent to those skilled in the art that various changes and modifications of the embodiments described herein can be made without departing from the scope and spirit of the present invention. In addition, descriptions of well-known functions and constructions are omitted for clarity and conciseness.

25 [0035] Embodiments of the invention are described herein with reference to illustrations of idealized embodiments (and intermediate structures) of the invention. As such, variations from the shapes of the illustrations as a result, for example, of manufacturing techniques and/or tolerances, are to be expected. Thus, embodiments of the invention should not be construed as limited to the particular shapes of regions  
30 illustrated herein but are to include deviations in shapes that result, for example, from manufacturing.

[0036] **FIGURE 1** through **FIGURE 7B** illustrate an exemplary display assembly 10. The display assembly 10 may comprise a cover 12. The cover 12 may comprise glass, acrylic, polymer, combinations thereof, or another material. In exemplary

embodiments, the cover 12 may comprise multiple layers, though such is not required. The layers of the cover 12 may comprise, for example, without limitation, a polarizer (linear, circular, etc.), an anti-reflective film, an optical adhesive, some combination thereof, or the like.

5 [0037] The cover 12 may be located forward of, and/or may form a portion of, an electronic display subassembly 44. In exemplary embodiments, the electronic display subassembly 44 may comprise one or more display layers (which may comprise liquid crystals, though such is not required), one or more diffusion layers, a backlight (direct or edge lit), or the like. Any type of electronic display subassembly 44 may be utilized  
10 including, but not limited to, LCD, LED, OLED, cathode ray tube, plasma, some combination thereof, or the like. The electronic display subassembly 44 may be of any size, kind, or type. The electronic display subassembly 44 may be provided in any orientation, including, but not limited to, portrait and/or landscape. More than one electronic display subassembly 44 may be utilized. In such embodiments, more than one  
15 cover 12 may be utilized, though such is not required.

[0038] The cover 12 may be attached to a frame 14. In exemplary embodiments, the frame 14 may define a hollow, rectangular shape, though such is not required. The frame 14 may be configured for mounting to a ground surface (e.g., street, sidewalk, etc.), a structure 48 (e.g., wall, post, etc.), or the like.

20 [0039] The cover 12 may define a surface area at least as large as the electronic display subassembly 44. The cover 12 may extend parallel to said electronic display subassembly 44. A front gap 46 may be provided between the cover 12 and the electronic display subassembly 44. For example, the front gap 46 may be located between a rear surface of the cover 12 and the front surface of the electronic display subassembly 44.

25 [0040] A rear compartment 18 may be located rearward of the electronic display subassembly 44. The rear compartment 18 may be located between a rear cover 16 and the electronic display subassembly 44. In exemplary embodiments, the rear compartment 18 may be located between a forward surface of the rear cover 16 and a rear surface of the electronic display subassembly 44.

30 [0041] The rear compartment 18 may be in fluid communication with the front gap 46, such as by way of one or more side channels 30. In exemplary embodiments, a first side channel 30 may extend on a first side of the display assembly 10 and a second side channel 30 may extend on a second side of the display assembly 10 such that circulating gas may form a loop about at least a portion of the electronic display subassembly 44.

The front gap 46, side channels 30, and rear compartment 18 may define a closed loop airflow pathway. The closed loop airflow pathway may encircle at least a portion of the electronic display subassembly 44, such as, but not limited to the display layer. The front gap 46, side channels 30, and rear compartment 18 may be entirely or substantially sealed to permit the continuous re-circulation of circulating gas, which may be substantially or entirely particulate free.

**[0042]** The circulating gas may be fully or partially isolated from ambient air. For example, without limitation, the circulating gas may comprise filtered ambient air which is recirculated one or more times. As another example, without limitation, the closed loop airflow pathway(s) may be separated from the open loop airflow pathway(s) such that the circulating gas is not permitted to substantially mix with the ambient air. However, a 100% hermetic type seal is not necessarily required between the closed loop airflow pathway(s) and the open loop airflow pathway(s) or ambient environment. Instead, the seal may be sufficient to meet one or more certain ingress protection code (IPC) standards, such as, but not limited to, IP65, IP67, or the like. The display assembly 110 may comprise one or more partitions, gaskets, walls, panels, combinations thereof, or the like, which provide separation between the ambient air in the open loop airflow pathway(s) and the circulation gas in the closed loop airflow pathway(s).

**[0043]** One or more electronic components 20 for operating the display assembly 10 may be located within the rear compartment 18. For example, the electronic components 20 may be located on the rear panel 16, the electronic display subassembly 44, or the like. Such electronic components 20 may comprise one or more processors, electronic storage devices, computing devices, network connectivity devices, computing devices, video players, power modules, combinations thereof, or the like.

**[0044]** One or more intakes 32 may be provided at the electronic display subassembly 44. The intakes 32 may be fluidly separated from the closed loop airflow pathway. The intakes 32 may be located above, or at least partially within but fluidly separated from, the rear compartment 18, though any location may be utilized. One or more exhausts 34 may be provided at the electronic display subassembly 44. The exhausts 34 may be fluidly separated from the closed loop airflow pathway. The exhausts 34 may be located below, or at least partially within but fluidly separated from, the rear compartment 18, though any location may be utilized. One or more interior channels 40 may extend between the intakes 32 and exhausts 34. In exemplary embodiments, the interior channels 40 extend along a rear surface of a backlight of the electronic display

subassembly 44, though such is not required. The interior channels 40 may comprise corrugation 42. The intakes 32, exhausts 34, and interior channels 40 may define an open loop airflow pathway. The intakes 32, exhausts 34, and interior channels 40 may be configured to receive ambient air. A shroud 38 may be provided about some or all of the  
5 intakes 32 and/or exhausts 34 to fluidly seal the intakes 32 and/or exhausts 34 from the rear compartment 18.

**[0045]** One or more open loop fans 22 may be provided along the open loop pathway. In exemplary embodiments, the open loop fans 22 are located adjacent to each of the exhausts 34. Each of the open loop fans 22 may comprise centrifugal fans oriented  
10 such that the gas flow inlet is oriented interior to the display assembly 10, such as immediately adjacent to an exit of the interior channel 40, and a discharge of the open loop fans 22 is adjacent to an ambient environment. In this way, a substantially 90 degree turn naturally required between the interior channels 40 and the exhaust 34 may be performed by the open loop fans 22. Furthermore, the placement and/or orientation of the  
15 open loop fans 22 may provide a thinner display assembly 10.

**[0046]** One or more closed loop fans 24 may be provided along the closed loop airflow pathway. In exemplary embodiments, the closed loop fans 24 are located within the rear compartment 18. The closed loop fans 24 may be positioned adjacent to one of the side channels 30. Each of the closed loop fans 24 may comprise centrifugal fans  
20 oriented such that the gas flow inlet is oriented towards the front gap 46, such as along a right side of the display assembly 10 when viewed from the rear, and a discharge of the closed loop fans 24 is configured to blow the circulating gas along the rear compartment 18. In this way, a substantially 90 degree turn naturally required between the front gap 46 and the rear compartment 18 may be performed by the closed loop fans 24. Furthermore,  
25 the placement and/or orientation of the closed loop fans 24 may provide a thinner display assembly 10. The closed loop fans 24 may further provide increased distribution of air within at least the rear compartment 18. For example, without limitation, the closed loop fans 24 may be centrifugal fans provided without certain customary shrouding, which may increase the number of directions the discharged air is distributed.

**[0047]** Dividers 26 may be positioned between at least some, or all, of the closed loop fans 24, though such dividers 26 are not required. The dividers 26 may provide some direction for airflow distribution through the rear compartment 18. Optionally, airflow deflection elements 28 may be positioned on distal ends of the dividers 26 or otherwise adjacent to the discharge of the closed loop fans 24 to further control airflow. The airflow

deflection elements 28 may comprise plates with various surface features, angles, holes, any combination thereof, or the like to direct airflow.

**[0048]** **FIGURE 8** through **FIGURE 14** illustrate another exemplary display assembly 110 in accordance with the present invention. The same or the similar features  
5 may be numbered similarly but increased by 100 (e.g., 10 to 110). The display assembly 110 may comprise one or more side assemblies 111. In exemplary embodiments, a first side assembly 111 is positioned opposite a second side assembly 111, though any number and arrangement of side assemblies 111 may be utilized. Each side assembly 111 may, in exemplary embodiments, comprise a cover 112, an electronic display  
10 subassembly 144, a front gap 146, an interior channel 140, corrugation 142, and side channels 130. Common or dedicated intakes 132 and exhausts 134 may be provided for the various side assemblies 111 and may form part of the open loop pathway(s) through the display assembly 110. In exemplary embodiments, common intakes 132 and dedicated exhausts 134 are utilized. In other exemplary embodiments, separate intakes  
15 132 and exhausts 134 are utilized so that each open loop airflow pathway has a dedicated airflow pathway. In this manner, ingested ambient air may remain entirely or substantially separated from one another while within the display assembly 10.

**[0049]** A common cavity 118 may be provided between two or more of the side assemblies 111 and may form part of a closed loop airflow pathway for each of the side  
20 assemblies 111. However, dedicated cavities 118 for each side assembly 111 may be utilized in other exemplary embodiments.

**[0050]** Electronic components 120 may be provided within the common cavity 118. For example, without limitation, such electronic components 120 may be provided at or  
25 along one or more of rear surfaces of the side assemblies 111. The common cavity 118, in exemplary embodiments, may be fluidly separated from ambient air. In this way, the electronic components 120 may be only exposed to circulating gas, which may be temperature controlled and/or kept substantially free of moisture, particulate, and/or other potential contaminants.

**[0051]** In exemplary embodiments, each side assembly 111 is moveably attached  
30 to a frame 114. Each of the open loop fans 122 are provided at or along an upper panel 113 at or along another panel of said frame 114. Said open loop fans 122 may be oriented such that a gas flow inlet faces upward to the ambient environment and a discharge portion is oriented to distribute ingested ambient air about the interior of the display assembly 10 for improved evenness of distribution to the side assemblies 111, as

particularly illustrated with respect to figure 10B. In exemplary embodiments, the open loop fans 122 may comprise centrifugal fans lacking certain shrouding features such that air is partially or wholly distributed about the open loop fans 122 to provide more even distribution.

5 **[0052]** In exemplary embodiments, each of the closed loop fans 124 may be provided along a side panel 115 at or along said frame 114. Each of the closed loop fans 124 may be oriented such that the gas flow intake ingests air from the front gaps 146 of each of the side assemblies 111 and is discharged about the common cavity 118, as particularly illustrated with respect to figures 11B and 14. In exemplary embodiments, the  
10 closed loop fans 124 may comprise centrifugal fans lacking certain shrouding features such that air is partially or wholly distributed about the closed loop fans 124 to provide more even distribution.

**[0053]** Examples of centrifugal fans shown and/or described herein may include, for example, without limitation, those provided by Sanyo Denki Co. Ltd. having a US office  
15 in Torrance, California under the San Ace brand (<https://products.sanyodenki.com/en/sanace/dc/centrifugal-fan/>). Such centrifugal fans may be utilized in 150mm, 133mm, and/or 100mm to name a few examples, without limitation. The centrifugal fans may be provided without some or all of the certain conventional shroud elements such that air is discharged about some or all of the fans.  
20 This may improve air distribution. As such centrifugal fans are interior to the display assembly 110, user safety may not be impacted by removing such shrouding elements.

**[0054]** Provided herein are certain exemplary test results from use of such centrifugal fans, as compared to axial fans within certain exemplary display assemblies 10, 100. Such centrifugal fans may be provided as open loop fans 22 and/or closed loop  
25 fans 24.

<b>centrifugal</b>						
content		white				
ft/min	ft/min	Zone	Zone Area (in2)	contributing area (in2)	contributing mass flow	
	470	1	26.27	7.0675	23.06753472	same as 9
430	440	2	21.99	5.4975	16.79791667	
430	450	3	15.71	3.9275	12.2734375	
450	450	4	9.42	2.355	7.359375	
450	450	5	3.14	3.14	9.8125	
440	450	4	9.42	2.355	7.359375	
430	450	3	15.71	3.9275	12.2734375	
440	450	2	21.99	5.4975	17.1796875	
445	470	1	26.27	7.0675	23.06753472	
ft/min	ft/min	Zone	Zone Area (in2)	contributing area (in2)	contributing mass flow	
	470	1	28.27	7.0675	23.06753472	same as 9
415	415	2	21.99	5.4975	15.84348958	
425	430	3	15.71	3.9275	11.72795139	
430	430	4	9.42	2.355	7.032291667	
435	440	5	3.14	3.14	9.594444444	
440	450	4	9.42	2.355	7.359375	
440	450	3	15.71	3.9275	12.2734375	
440	460	2	21.99	5.4975	17.56145833	
440	470	1	28.27	7.0675	23.06753472	
				<b>Total Centrifugal Mass Flow</b>	<b>257</b>	

Table 1 – Centrifugal Fan Results

<b>92</b>					
content		white			
ft/min	ft/min	Zone	Zone Area (in2)	contributing area (in2)	contributing mass flow
	460	1	28.27	7.0675	22.57673611
435	420	2	21.99	5.4975	16.034375
440	440	3	15.71	3.9275	12.00069444
460	450	4	9.42	2.355	7.359375
465	460	5	3.14	3.14	10.03055556
465	450	4	9.42	2.355	7.359375
460	460	3	15.71	3.9275	12.54618056
460	470	2	21.99	5.4975	17.94322917
450	460	1	28.27	7.0675	22.57673611
ft/min	ft/min	Zone	Zone Area (in2)	contributing area (in2)	contributing mass flow
	400	1	28.27	7.0675	19.63194444
440	450	2	21.99	5.4975	17.1796675
480	465	3	15.71	3.9275	12.60255208
480	460	4	9.42	2.355	7.522916667
475	460	5	3.14	3.14	10.03055556
460	430	4	9.42	2.355	7.032291667
420	410	3	15.71	3.9275	11.18246528
410	410	2	21.99	5.4975	15.65260417
400	400	1	28.27	7.0675	19.63194444
				<b>Total 92</b>	
				<b>Axial</b>	
				<b>Mass</b>	
				<b>Flow</b>	<b>249</b>

Table 2 – Axial Fan Results

[0055] As demonstrated from the above, better mass flow rate is achieved with the use of centrifugal fans. The use of such centrifugal fans also resulted in about four times less noise and about half the power usage as the axial fans. The presented testing results are for exemplary demonstration purposes and are in no way intended to be limiting.

[0056] In certain exemplary embodiments, electric vehicle charging equipment 150 may be provided at, or in association with, the display assemblies 10, 110. The electric

vehicle charging equipment 150 in exemplary embodiments may be anchored to the frame 114 and/or the ground or other surface (directly or indirectly). The electric vehicle charging equipment 150 in exemplary embodiments may be electrically connected to the same power source as used to power the display assembly 10, 110, which may include utility power, battery power, solar power, combinations thereof, or the like. Some or all of the electric vehicle charging equipment 150 may be located between the side assemblies 111, though some or all of the electric vehicle charging equipment 150 may be located elsewhere.

**[0057]** The frame 114 may be adapted to accommodate the electrical vehicle charging equipment 150. For example, without limitation, the frame 114 may comprise a recessed portion comprising, or configured to accommodate, a housing 151 for at least some of the electric vehicle charging equipment 150 that extends into a portion of the cavity 118. The electric vehicle charging equipment 150 may be fully or partially recessed when a handle or other electric vehicle connection portion of the electric vehicle charging equipment 150 is docked at the display assembly 110 (e.g., not in use), such as at a receiver at or within the housing 151. For example, without limitation, a cord and/or the handle portion of the electric vehicle charging equipment 150 may extend from the frame 114 and/or outside of the housing 151. In exemplary embodiments, the electrical vehicle charging equipment 150 may be attached to a portion of the frame 114 extending between the side assemblies 111 such that the electrical vehicle charging equipment 150 is accessible from the side. Placing the electrical vehicle charging equipment 150 between the side assemblies 111 may result in a shorter overall height of the display assembly 110 which may be particularly advantageous for shipping.

**[0058]** One or more separate intakes/exhausts 132/134 and open and/or closed loop airflow pathways may be provided for some or all of the electric vehicle charging equipment 150, though such is not required. For example, some or all of the electric vehicle charging equipment 150 may have a dedicated open loop airflow pathway separate from other open loop airflow pathways for the display assembly 110. Alternatively, or additionally, the airflow for the electric vehicle charging equipment 150 may share one or more common intakes/exhausts 132/134 and open and/or closed loop airflow pathways with the side assemblies 111. For example, some or all of the electric vehicle charging equipment 150 may share an open loop airflow pathway with at least one of the side assemblies 111. Alternatively, or additionally, some or all of the electric vehicle charging equipment 150 may be thermally managed, at least in part, by the circulating gas

within the common cavity 118. For example, without limitation, the circulating gas within the common cavity 118 may pass over interior surfaces of the housing 151 that extend within the common cavity 118, and/or certain power or other electronic components mounted at such interior surfaces of the housing 151 or otherwise within the common  
5 cavity 118.

**[0059]** The display assembly 110 may be configured to accommodate one or multiple electric vehicle chargers and related equipment 150. The display assembly 110 may be configured to accommodate various sizes and/or types of electric vehicle chargers and related equipment 150 positioned at various locations of the display assembly 110.

10 For example, without limitation, electric vehicle connector portions (e.g., handles, plugs, outlets, adapters, connectors, or other components for docking with electric vehicles) may be provided at each side of the display assembly 110 for connecting with EV to charge the EV.

**[0060]** One or more additional equipment cavities 152 may be provided below,  
15 above, and/or adjacent to the side assemblies 111. For example, without limitation, a single additional equipment cavity 152 may be provided below, and at least partially between, the side assemblies 111. Electronic components 120 may be provided within the additional equipment cavity or cavities 152. Such electronic components 120 may  
20 comprise, for example, without limitation, components for operating the side assemblies 111 (e.g., electronic storage devices, processors, video players, network connectivity devices, power supplies, sensors, combinations thereof, or the like), components of, or for operating, the electric vehicle charging equipment 150 (e.g., power supplies, power transformers, capacitors, charge load centers, power meters, wiring, cords, handles, adapters, etc.), customer equipment or components for operating the same (e.g., network  
25 connectivity devices, cameras, sensors, microphones, telephonic equipment, emergency beacons, etc.), combinations thereof, or the like. More than one additional equipment cavity 152 at more than one location may be provided.

**[0061]** Some or all of the additional equipment cavities 152 may comprise shared or dedicated thermal management and/or power supplies with the side assemblies 111.

30 In exemplary embodiments, without limitation, one or more separate intakes 132 and exhausts 134 are provided to facilitate a dedicated open loop airflow pathway through the additional equipment cavity 152. In other exemplary embodiments, without limitation, the additional equipment cavity 152 may share intakes 132 and/or exhausts 134 with one or

more of the side assemblies 111, or otherwise form part of the open loop airflow pathways for the side assemblies 111.

**[0062]** Some or all of the electric vehicle (“EV”) charging equipment 150 may be fully or partially recessed between the side assemblies 111. The EV charging equipment 5 150 may be connected, directly or indirectly, to the frame 114 and/or the side assemblies 111. Certain components of the EV charging equipment 150, such as, but not limited to, handles, connectors, adapters, cords, holsters, docks, combinations thereof, or the like may be fully or partially external to the display assembly 110. External components of the EV charging equipment 150 may be provided at, outside of, or connected to, exterior 10 surfaces of a housing 151. The housing 151 may be fully or partially recessed into the common cavity 118 between the side assemblies 111. The size and/or shape of the housing 151 may be configured to accommodate various types or kinds of EV charging equipment 150. Certain components of the EV charging equipment 150, such as, but not limited to, power supplies, power regulators, transformers, power meters, batteries, 15 electric grid connectors, combinations thereof, or the like may be fully or partially internal to the display assembly 110. Internal components of the EV charging equipment 150 may be provided within or at the side assemblies 111 and/or the additional equipment cavity or cavities 152. The additional equipment cavity 152 may comprise one or more ambient air pathways, which may be dedicated or form part of other open loop airflow pathways within 20 the display assemblies 110. For example, without limitation, the additional equipment cavity 152 may comprise its own intake 132’ and may utilize one or more of the exhausts 134 utilized by the side assemblies 111. As another example, without limitation, the additional equipment cavity 152 may comprise its own dedicated intake 132’ and its own dedicated exhaust 134’ such that ambient air circulating about the EV charging equipment 25 150 and/or other components in the additional equipment cavity 152 is kept separate from other open loop air.

**[0063]** The EV charging equipment 150 may comprise any type or kind of EV charger and associated equipment, such as but not limited to a level 2 charger.

**[0064]** **FIGURE 15A** through **FIGURE 15D** illustrate various exemplary electrical 30 schematics for the display assemblies 110. In exemplary embodiments, the side assemblies 111 and the EV charging equipment 150 may be connected to a common power supply 153, such as, but not limited to, the electrical grid, solar panels, wind turbines, power generators, combinations thereof, or the like. Such electronic connection to the power supply 153 may be made by way of a common connection point or line 155,

such as shown with particular regard to figures 15A-15C, or separate connection points or lines 155a, 155b, to the same or different power supplies 153, such as shown with particular regard to figure 15D. The EV charging equipment 150 may comprise any number of EV electric vehicle connector portions for any number or type of electric  
5 vehicles.

**[0065]** Optionally, one or more bulk energy storage devices 157, such as, but not limited to, one or more batteries, may be utilized with the display assemblies 110. The bulk energy storage devices 157 may be part of the EV charging equipment 150 or separate therefrom. In exemplary embodiments, the bulk energy storage devices 157 are  
10 electrically interposed between an electric vehicle connector portion of the EV charging equipment 150 and the power supply 153, though such is not required. In other exemplary embodiments, such as shown with particular regard to figure 15C, the bulk energy storage devices 157 may be electrically interposed between the electric vehicle connector portions of the EV charging equipment 150 and the side assemblies 111. The bulk energy storage  
15 devices 157 may act as the power supply 153 and/or a supplementary and/or alternative power supply 153 in exemplary embodiments.

**[0066]** One example of such EV charging equipment 150 includes, for example without limitation, electric vehicle chargers and related equipment provided available from ChargePoint, Inc. of Campbell, California (<https://www.chargepoint.com/>). Another  
20 example of such EV charging equipment 150 includes, for example without limitation, electric vehicle chargers and related equipment available from by EV-Box North America Inc. of Libertyville, Illinois (<https://evbox.com/us-en/>).

**[0067]** In exemplary embodiments, without limitation, the housing 151 may be fully or partially enclosed in a manner which fully or partially seals an interior space of the  
25 housing 151 from ambient air. For example, without limitation, the housing 151 may comprise one or more enclosures conforming to one or more environmental protection ratings, such as but not limited to, National Electrical Manufacturer Association (NEMA) 1, 2, 3, 3R, 3X, 3RX, 3S, 3SX, 4, 4X, 5, 6, 6P, 12, 12K and/or 13.

**[0068]** The housing 151 may extend entirely or partially within the frame 114. The  
30 housing 151 may extend entirely or partially outside of the frame 114. The housing 151 may be connected, directly or indirectly, to the frame 115. The housing 151 may be provided as, as part of, or within, the additional equipment cavity 152 in exemplary embodiments.

**[0069]** In exemplary embodiments, without limitation, some or all of the EV charging equipment 150 may be provided within the housing 151. However, one or more electrical power supply lines may extend through the housing 151 and/or the frame 114 to connect with other electrical power supply lines for the subassemblies 111 and/or other components of the display assemblies 110, such as to provide the common connection line or point 155 to the power supply or supplies 153, though such is not required.

**[0070]** Any embodiment of the present invention may include any of the features of the other embodiments of the present invention. The exemplary embodiments herein disclosed are not intended to be exhaustive or to unnecessarily limit the scope of the invention. The exemplary embodiments were chosen and described in order to explain the principles of the present invention so that others skilled in the art may practice the invention. Having shown and described exemplary embodiments of the present invention, those skilled in the art will realize that many variations and modifications may be made to the described invention. Many of those variations and modifications will provide the same result and fall within the spirit of the claimed invention. It is the intention, therefore, to limit the invention only as indicated by the scope of the claims.

**[0071]** Certain operations described herein may be performed by one or more electronic devices. Each electronic device may comprise one or more processors, electronic storage devices, executable software instructions, and the like configured to perform the operations described herein. The electronic devices may be general purpose computers or specialized computing devices. The electronic devices may comprise personal computers, smartphones, tablets, databases, servers, or the like. The electronic connections and transmissions described herein may be accomplished by wired or wireless means. The computerized hardware, software, components, systems, steps, methods, and/or processes described herein may serve to improve the speed of the computerized hardware, software, systems, steps, methods, and/or processes described herein.

## CLAIMS

1. A display assembly with integrated electric vehicle charging equipment, said display assembly comprising:
  - a structural frame;
  - a first side assembly connected to a first side of said structural frame, said first side assembly comprising a first cover and a first electronic display subassembly located behind said first cover;
  - a second side assembly connected to a second side of said structural frame, said second side assembly comprising a second cover and a second electronic display subassembly located behind said second cover;
  - a recessed compartment extending inward to the display assembly between said first side assembly and said second side assembly; and
  - said electric vehicle charging equipment, wherein said electric vehicle charging equipment is located between said first side assembly and said second side assembly;
  - wherein a first portion of the electric vehicle charging equipment is provided within the recessed compartment, and a second portion of the electric vehicle charging equipment is provided interior to the structural frame.
  
2. The display assembly of claim 1 wherein:
  - the first portion of said electric vehicle charging equipment includes at least an electric vehicle connector portion, is exposed to an exterior of the display assembly, and is fully recessed within the recessed compartment when the electric vehicle connector portion is docked at the display assembly.
  
3. The display assembly of claim 1 further comprising:

a common cavity between said first side assembly and said second side assembly, wherein the second portion of the electric vehicle charging equipment is located within the common cavity;

a closed loop airflow pathway for circulating gas comprising a first portion extending within said first side assembly, a second portion extending within said second side assembly, and said common cavity; and

a housing for at least some of said electric vehicle charging equipment at least partially recessed into said common cavity.

4. The display assembly of claim 3 further comprising:

at least one loop airflow pathway for ambient air.

5. The display assembly of claim 4 wherein:

said at least one open loop airflow pathway comprises a first open loop airflow pathway extending through said first side assembly and a second open loop airflow pathway extending through said second side assembly.

6. The display assembly of claim 5 further comprising:

a common intake for said first open loop airflow pathway and said second open loop airflow pathway located at an upper portion of said first and second side assemblies;

a first exhaust for said first open loop airflow pathway;

a second exhaust for said second open loop airflow pathway; and

a common set of open loop fans located adjacent to said common intake, wherein said common set of open loop fans comprise centrifugal type fans oriented to

distribute ingested ambient air into both of said first open loop airflow pathway and said second open loop airflow pathway when operated.

7. The display assembly of claim 6 wherein:

each of said centrifugal type fans of said common set of open loop fans are provided without a shroud.

8. The display assembly of claim 6 further comprising:

a set of one or more closed loop fans located within said common cavity for moving circulating gas through said closed loop airflow pathway when operated.

9. The display assembly of claim 8 further comprising:

a side panel located within said common cavity and oriented perpendicular to a front surface of said first side assembly and a front surface of said second side assembly, wherein each fan in said set of one or more closed loop fans comprises a centrifugal type fan spaced apart vertically along said side panel.

10. The display assembly of claim 5 wherein:

said first electronic display subassembly comprises a first LCD display layer and a first backlight;

said second electronic display subassembly comprises a second LCD display layer and a second backlight;

said first open loop airflow pathway extends directly adjacent to the first backlight;

said second open loop airflow pathway extends directly adjacent to the second backlight;

said first portion of said closed loop airflow pathway is located between said first cover and said first LCD display layer of said first electronic display subassembly; and

said second portion of said closed loop airflow pathway is located between said second cover and said second LCD display layer of said second electronic display subassembly.

11. The display assembly of claim 2 further comprising:

an additional equipment cavity located below, and at least partially between, said first side assembly and said second side assembly, wherein the second portion of the electric vehicle charging equipment is located within said additional equipment cavity.

12. The display assembly of claim 11 further comprising:

a dedicated open loop airflow pathway through said additional equipment cavity.

13. The display assembly of claim 1 further comprising:

a first gasket provided at said structural frame between said structural frame and said first side assembly, wherein said first side assembly is moveably connected to said structural frame between a closed position where said first gasket is compressed between said first side assembly and said structural frame and an open position where an edge of said first side assembly is rotated away from said structural frame; and

a second gasket provided at said structural frame between said structural frame and said second side assembly, wherein said second side assembly is moveably connected to said structural frame between a closed position where said second gasket is compressed between said second side assembly and said structural frame and an open position where an edge of said second side assembly is rotated away from said structural frame.

14. The display assembly of claim 1 further comprising:

a common power source for said first side assembly, said second side assembly, and said electric vehicle charging equipment.

15. A display assembly with integrated electric vehicle charging equipment and forced air cooling, said display assembly comprising:

a frame;

a first side assembly moveably connected to a first side of said frame and comprising:

a first cover;

a first electronic display layer located behind said cover; and

a first backlight located behind said first electronic display layer;

a second side assembly moveably connected to a second side of said frame and comprising:

a second cover;

a second electronic display layer located behind said second cover; and

a second backlight located behind said second electronic display layer;

one or more intakes;

one or more exhausts;

one or more interior channels extending within said frame and between said first electronic display layer and said second electronic display layer;

one or more open loop pathways comprising said one or more intakes, said one or more interior channels, and said one or more exhausts;

one or more fans configured to move ambient air through said one or more open loop pathways when activated;

a cavity positioned between said first and second side assemblies and housing at least some internal components of the electric vehicle charging equipment;

a housing recessed from said frame to extend inward to protrude within said cavity, said housing accommodating at least some exterior components of said electric vehicle charging equipment when docked at the display assembly; and

an additional storage area located below or between said first and second side assemblies for accommodating at least some other interior components of said electric vehicle charging equipment;

wherein at least said first side assembly, said second side assembly, and said electric vehicle charging equipment are electrically connected to a common power supply.

16. The display assembly of claim 15 wherein:

said first side assembly, said second side assembly, and said electric vehicle charging equipment are electrically connected to said common power supply by way of a common power line or connection point.

17. The display assembly of claim 15 wherein:

each of said one or more fans comprise centrifugal type fans positioned adjacent to said one or more intakes;

said one or more intakes are located at an upper portion of said frame;

said one or more exhausts are located at a lower half of said frame;

said one or more centrifugal type fans are provided without an outer shroud about the impeller; and

said one or more centrifugal type fans are configured to, when activated, ingest ambient air and distribute said ingested ambient air through each of multiple ones of said one or more interior channels.

18. The display assembly of claim 17 further comprising:

a closed loop airflow pathway comprising said cavity, a first portion extending through said first side assembly, and a second portion extending through said second side assembly, wherein at least some of the interior components of said electric vehicle charging equipment are located within said cavity, wherein said one or more closed loop fans each comprise centrifugal type fans provided without a shroud for disbursing circulating gas within said cavity in a turbulent manner when activated.

19. The display assembly of claim 18 further comprising:

a first front gap located between said first cover and said first electronic display layer;

a second front gap located between said second cover and said second electronic display layer, wherein said closed loop airflow pathway comprises said first front gap and said second front gap; and

one or more closed loop fans positioned within said cavity and configured to force circulating gas through said closed loop airflow pathway when activated.

**Manufacturing Resources International, Inc.**  
**Patent Attorneys for the Applicant/Nominated Person**  
**SPRUSON & FERGUSON**

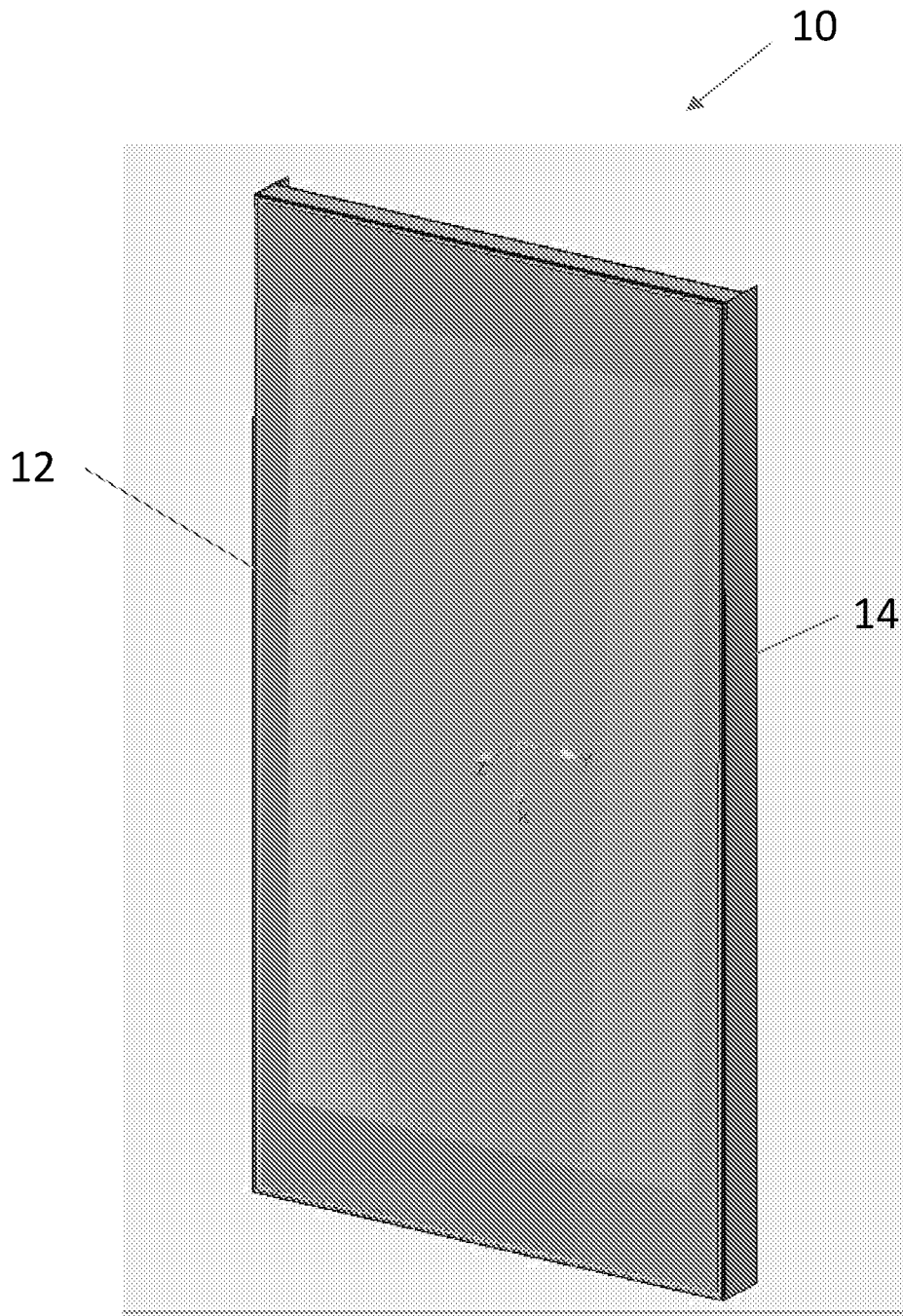

Figure 1

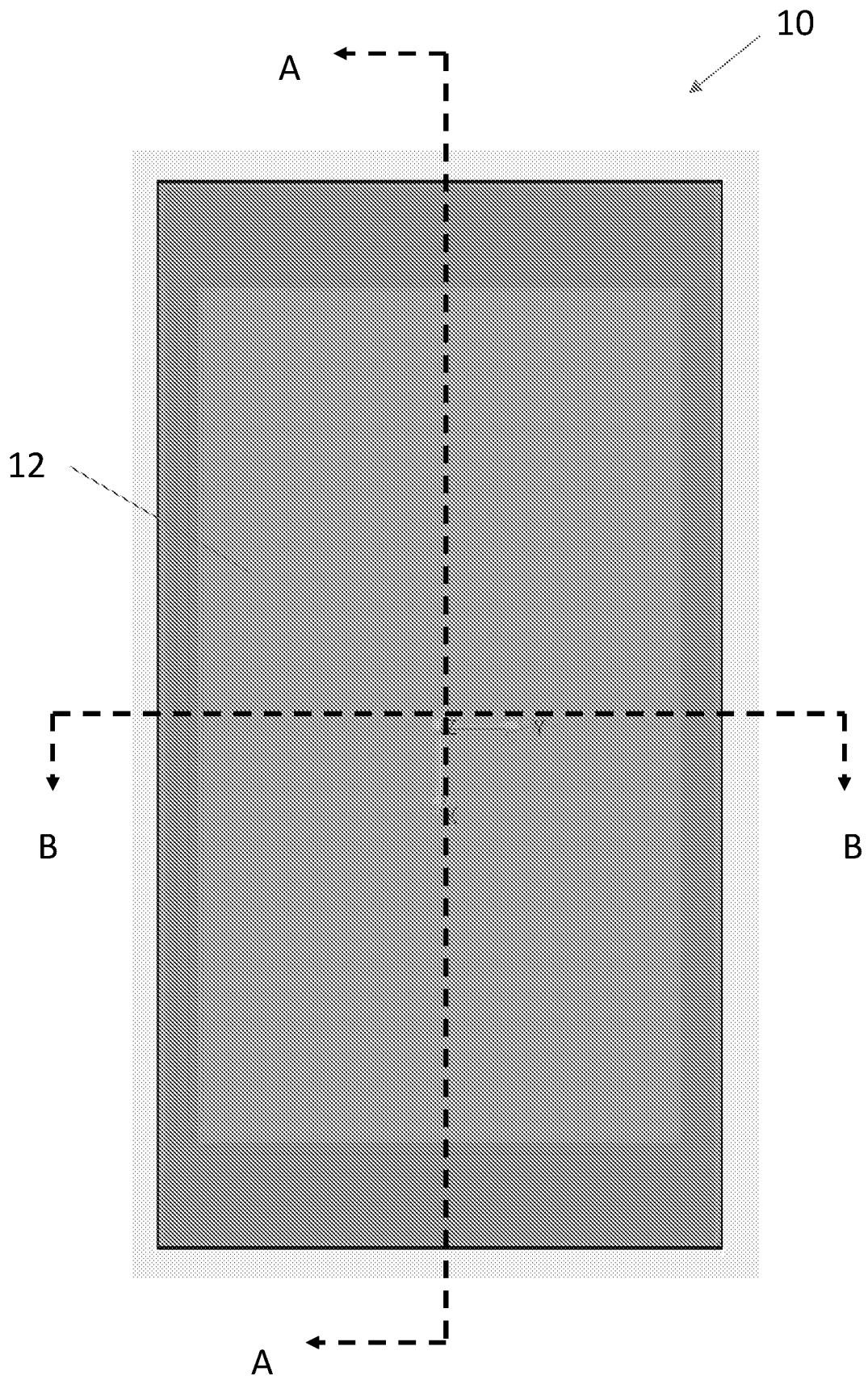

Figure 2

3/18

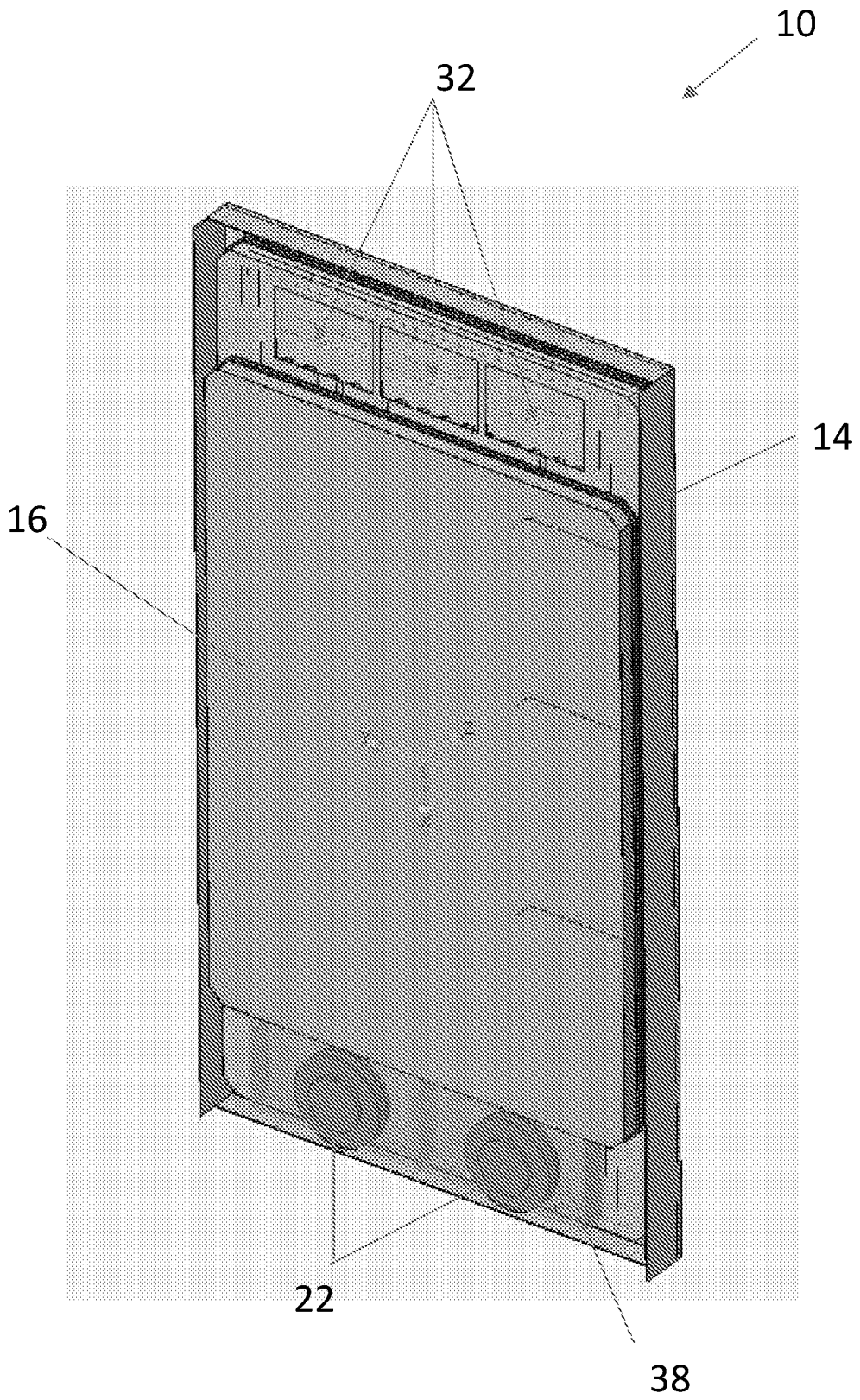

Figure 3

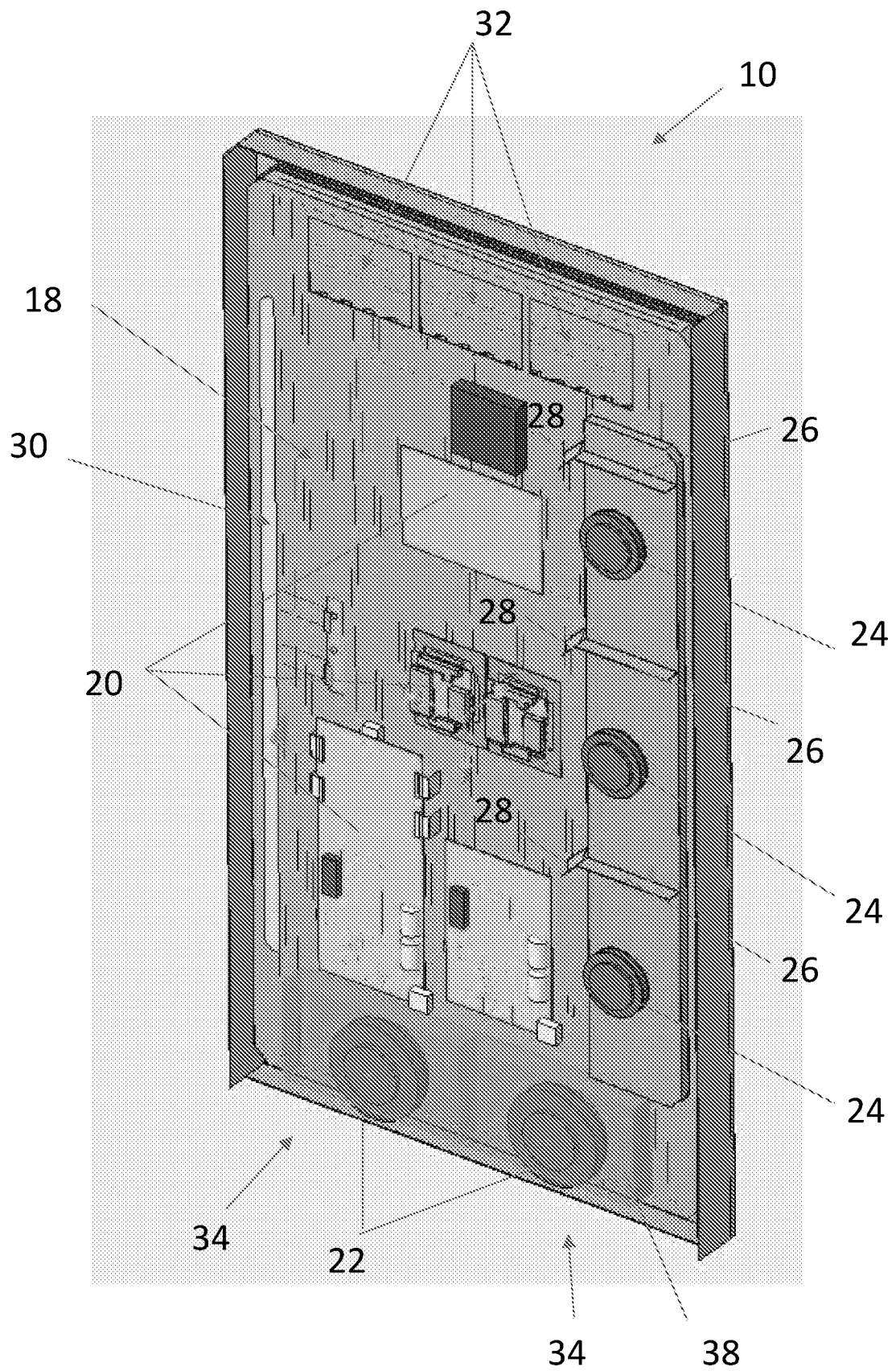

Figure 4

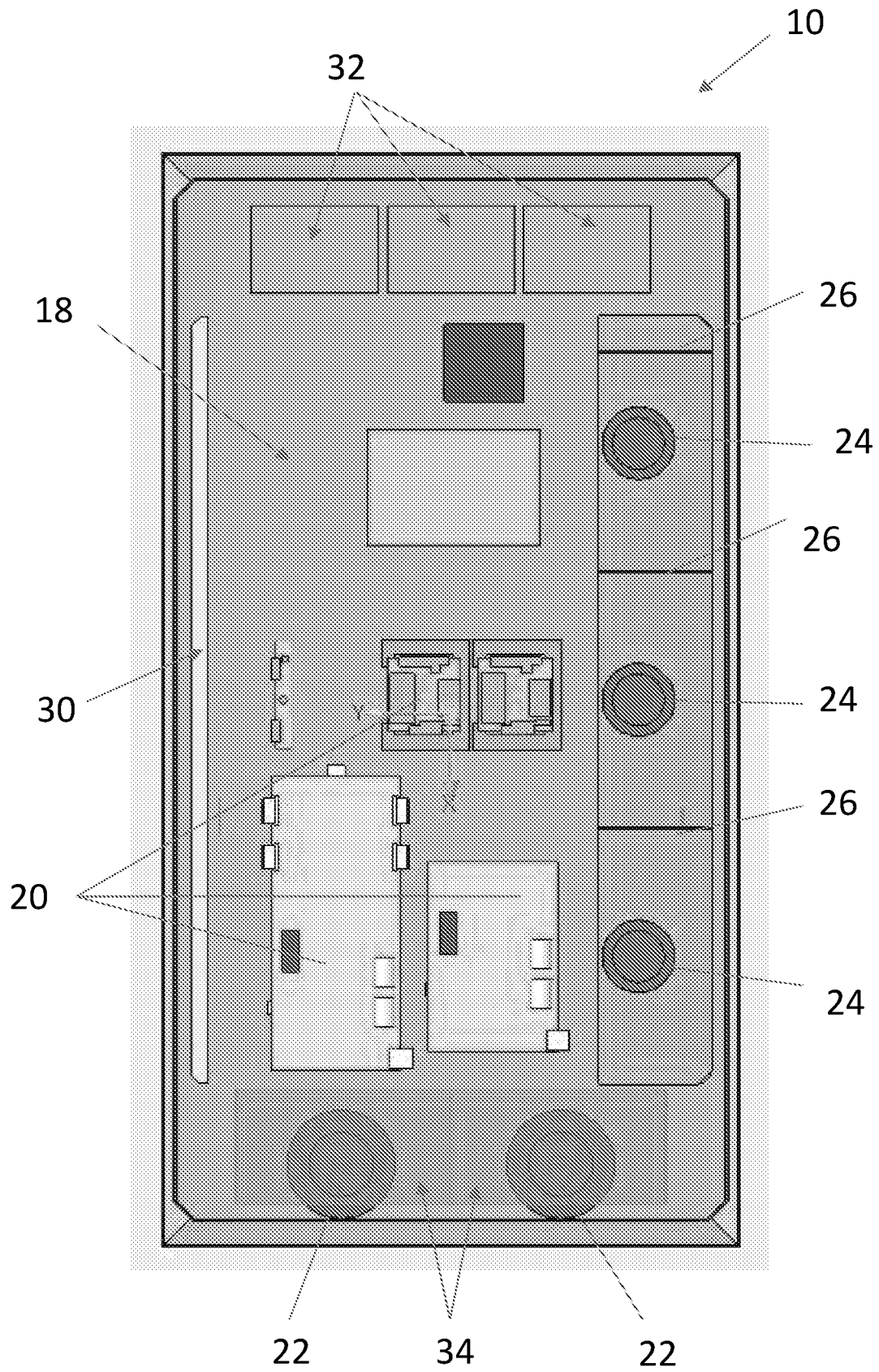

Figure 5

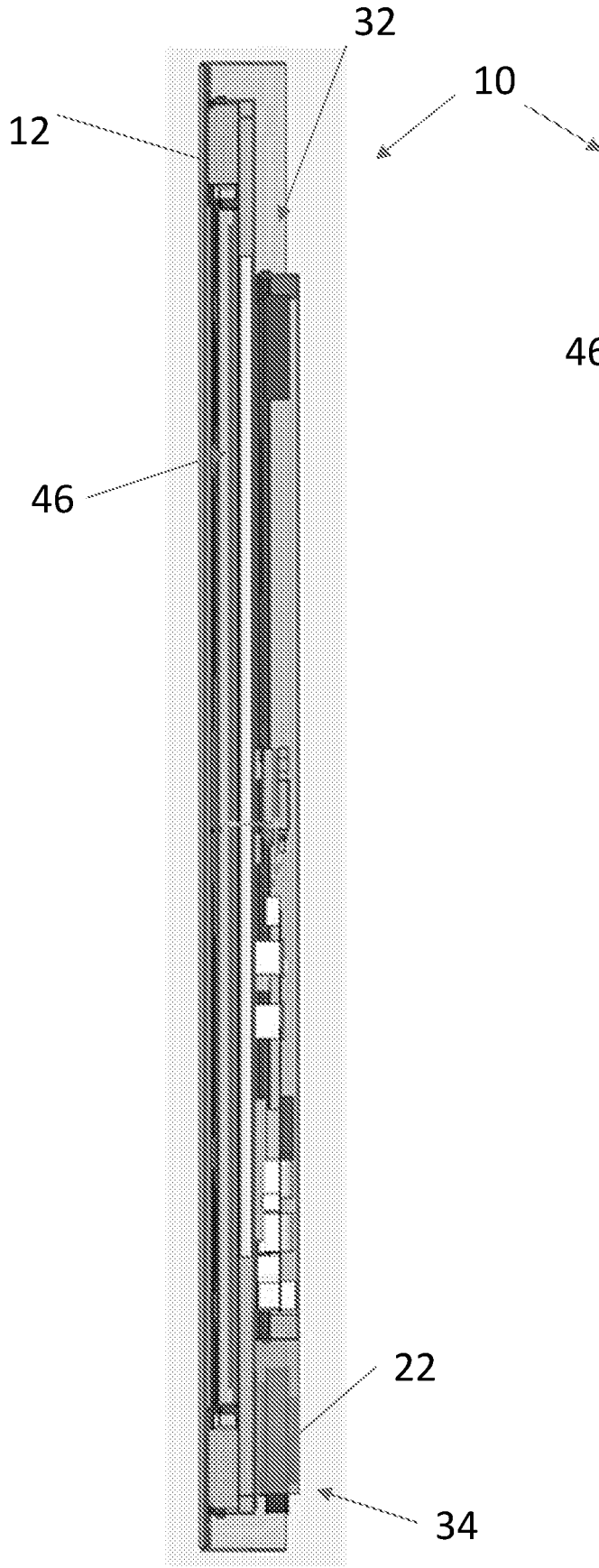

Figure 6A

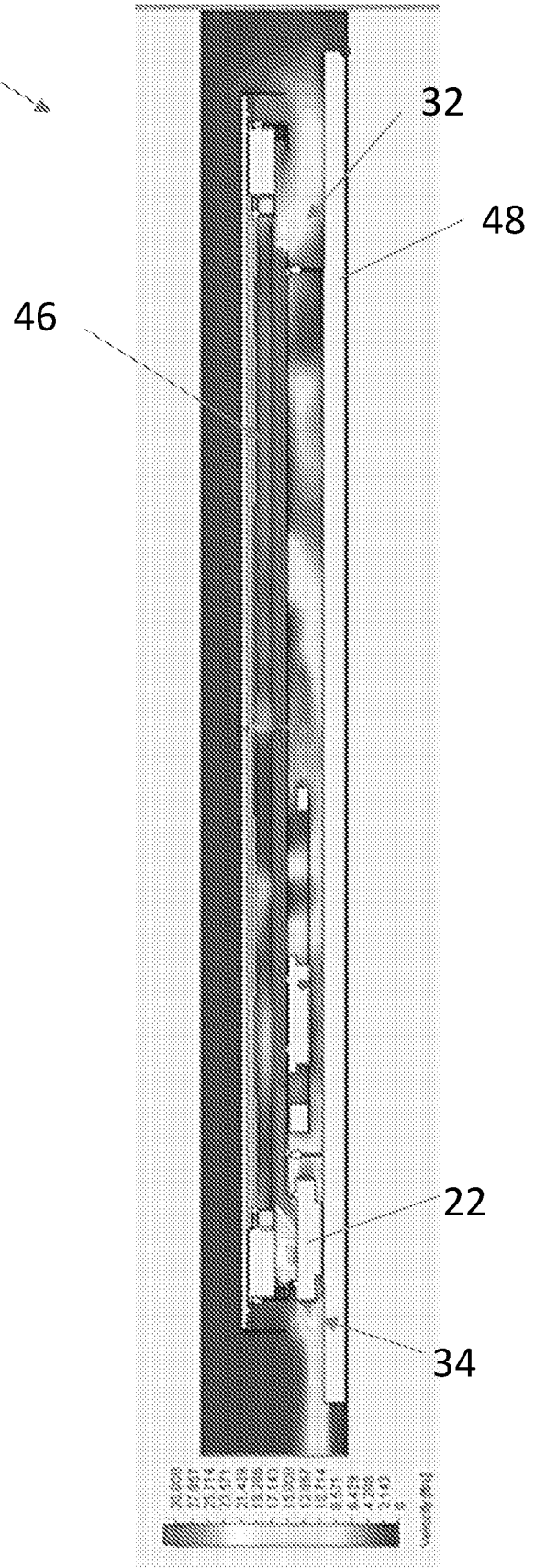

Figure 6B

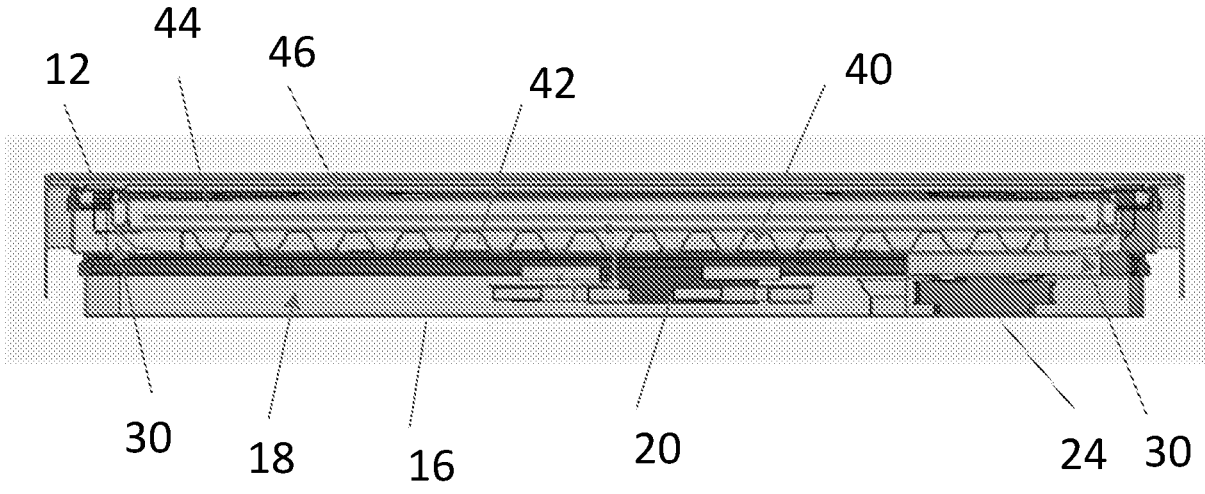

Figure 7A

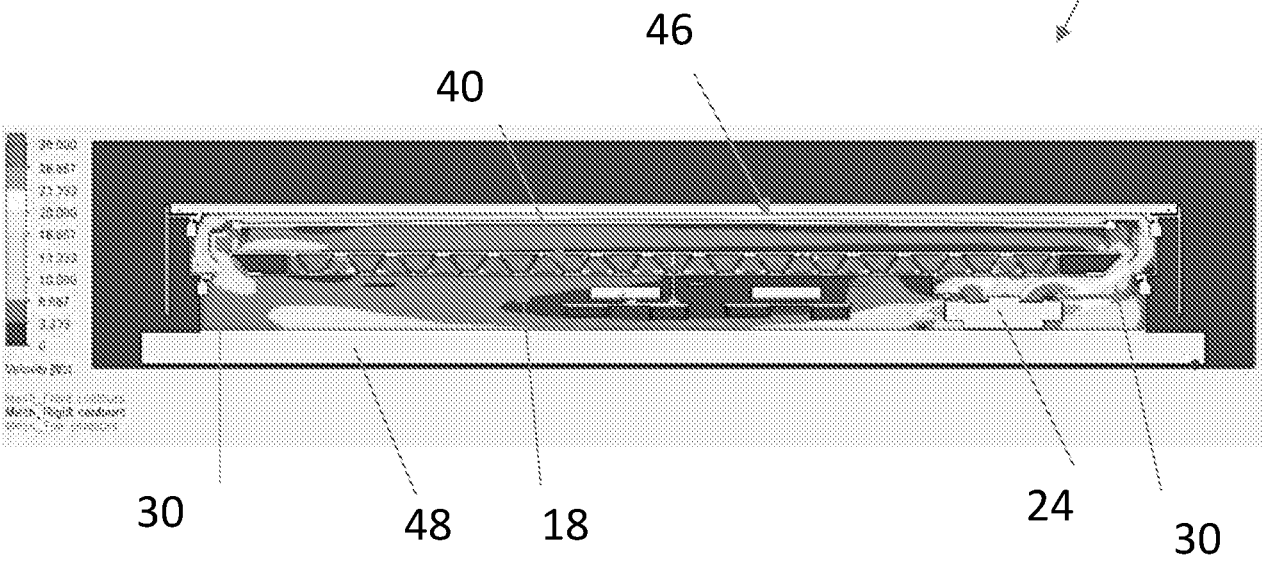
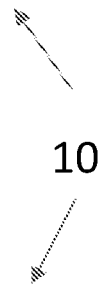

Figure 7B

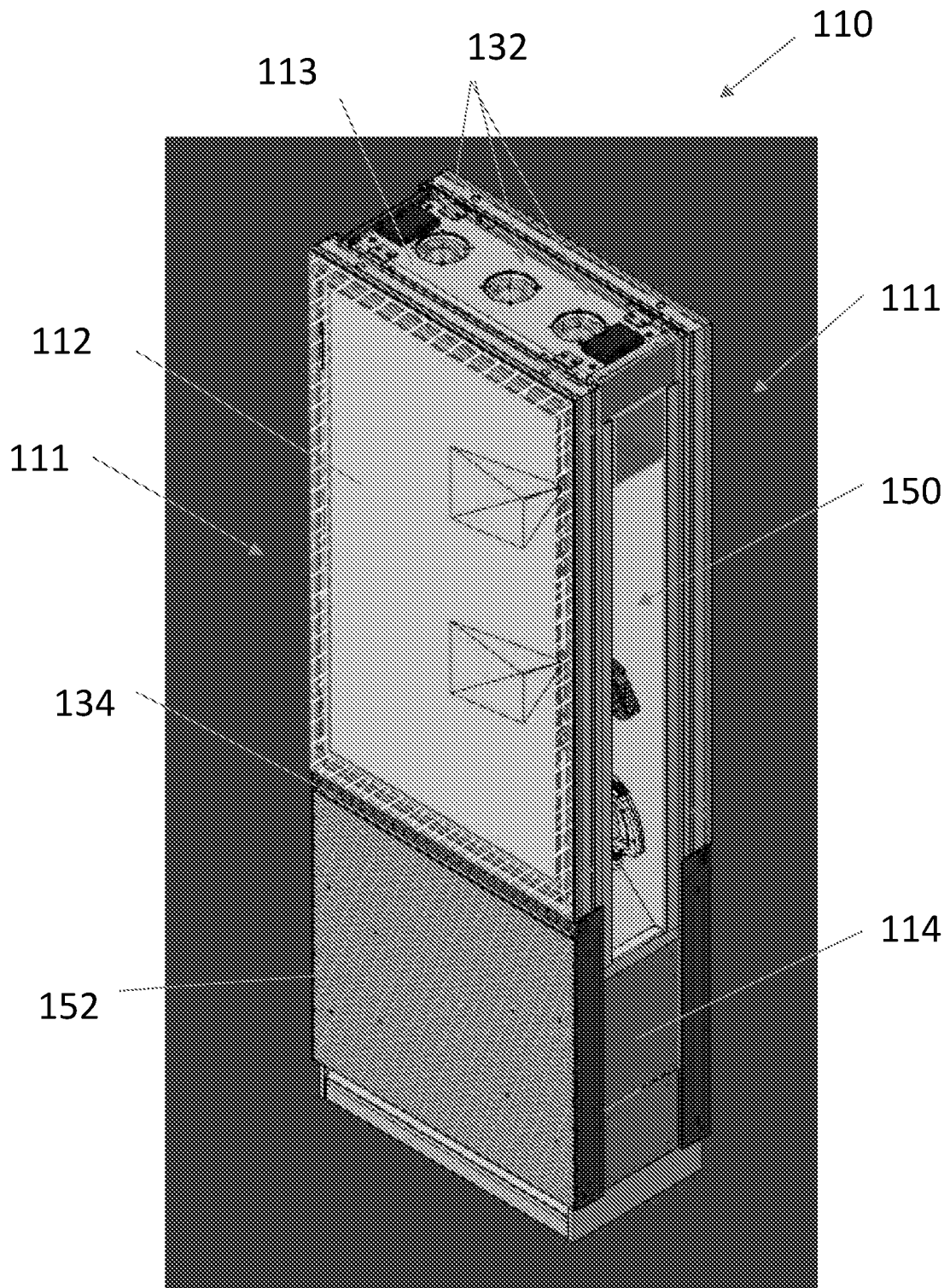

Figure 8

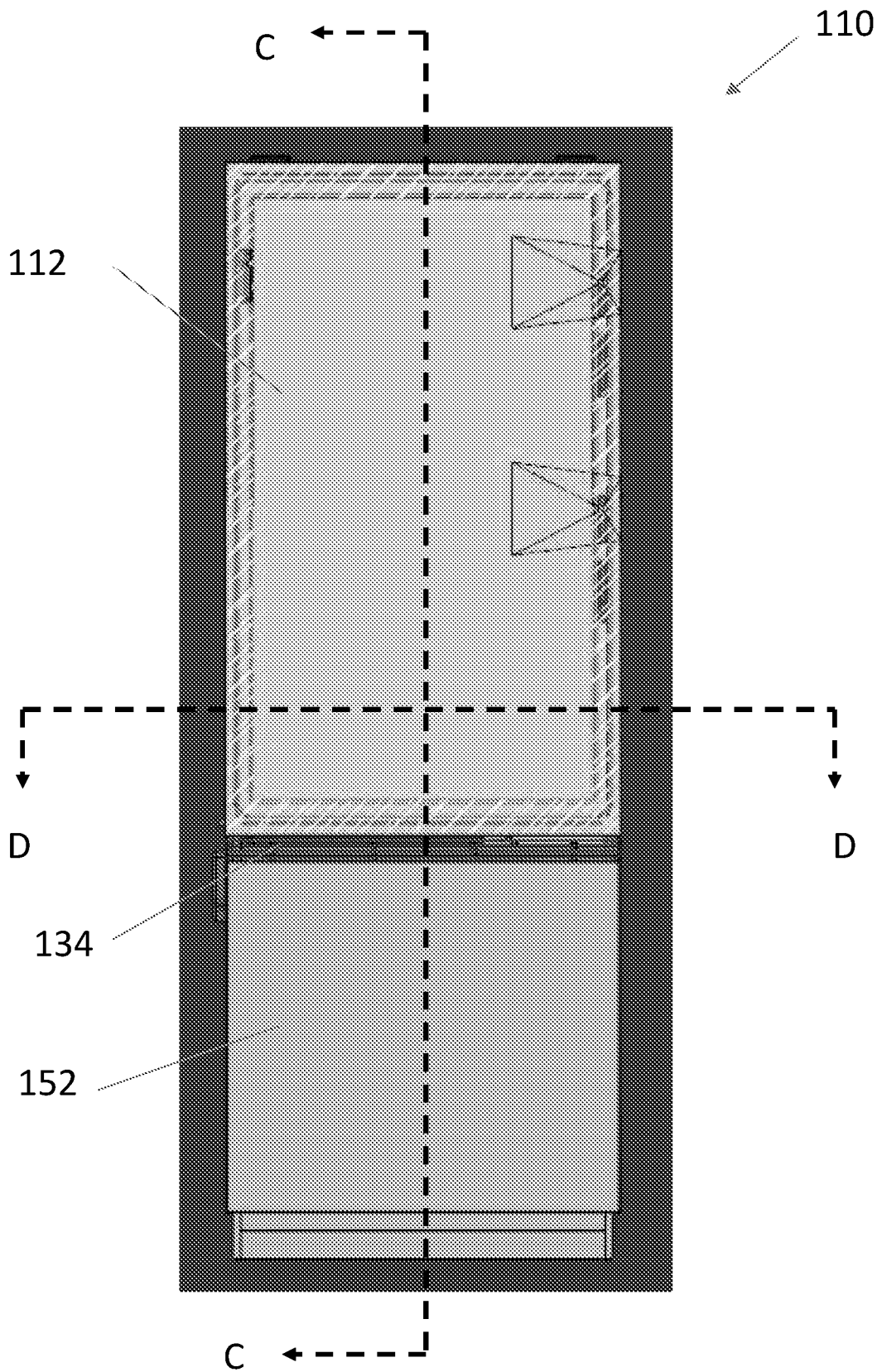

Figure 9

10/18

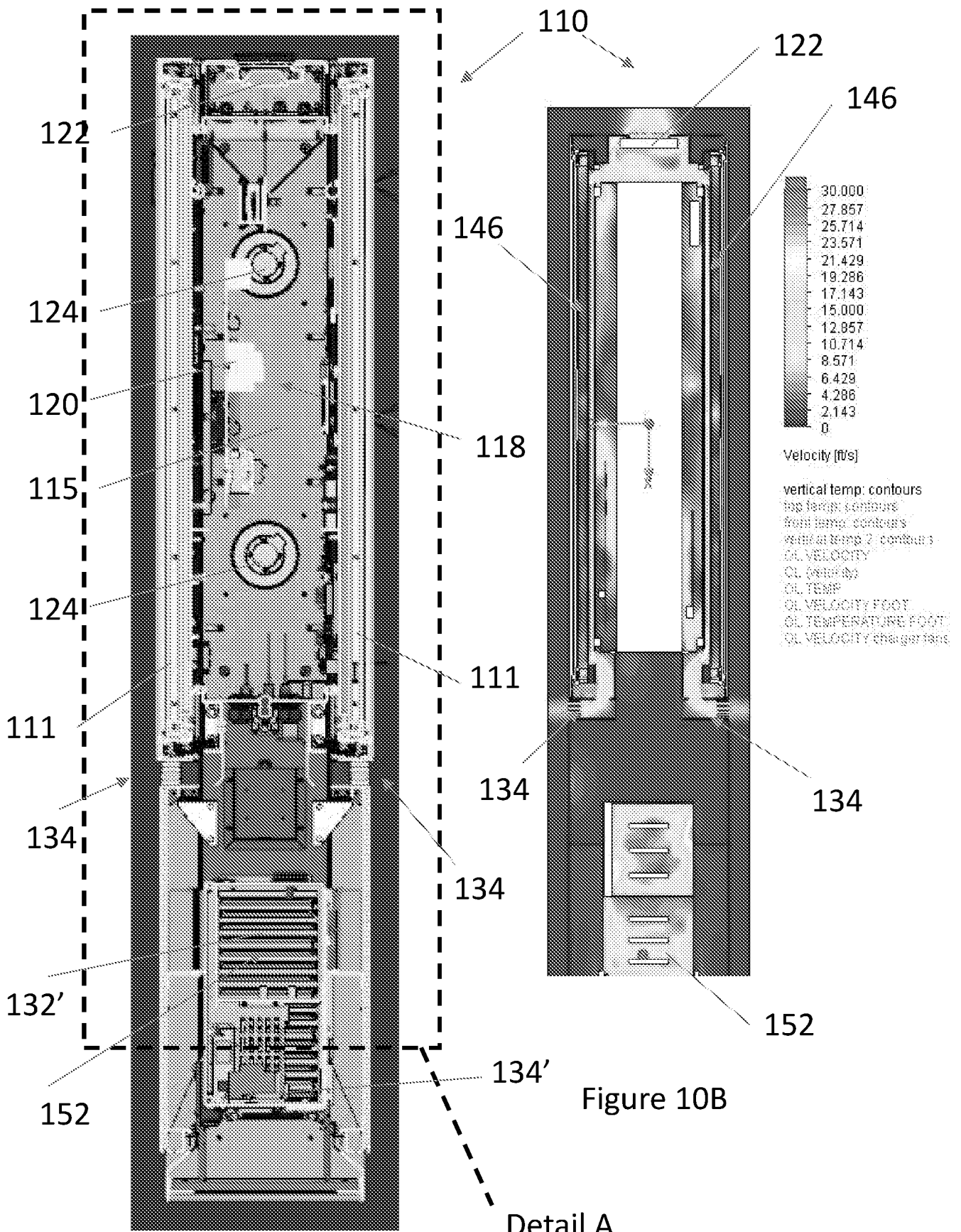

Figure 10A

Figure 10B

Detail A

11/18

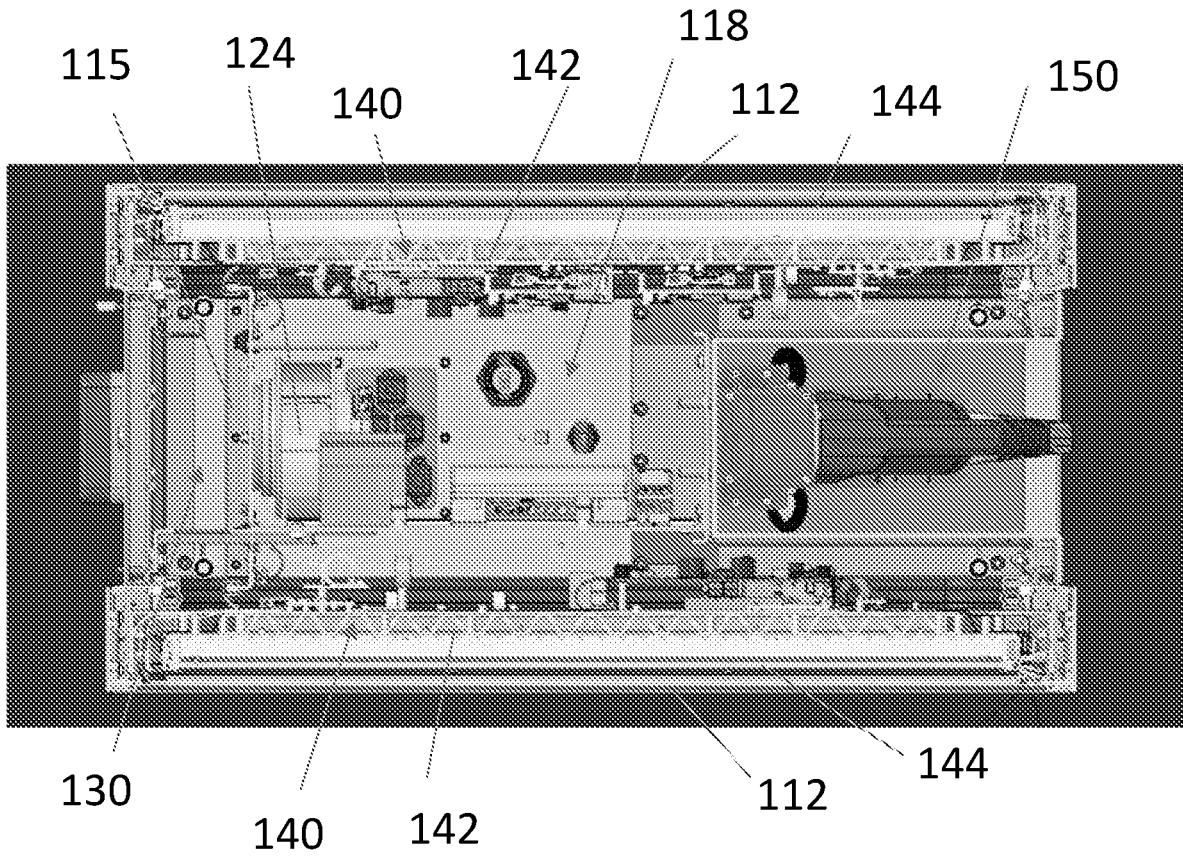

Figure 11A

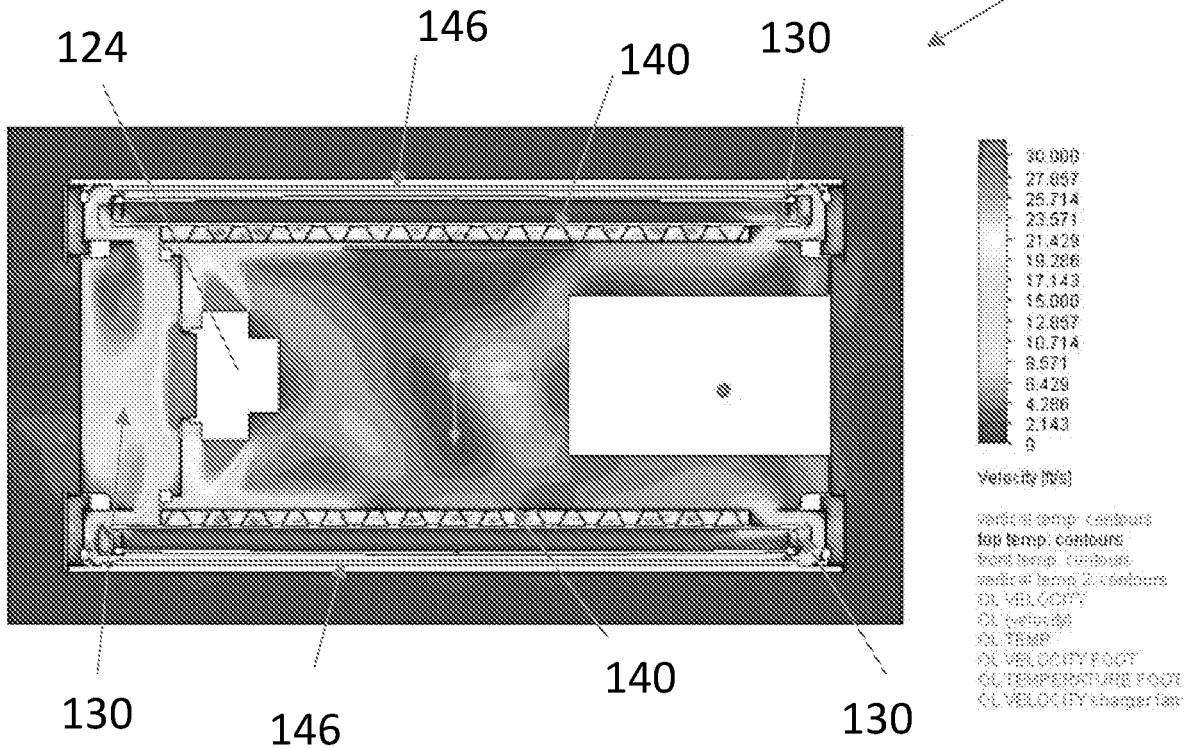

Figure 11B

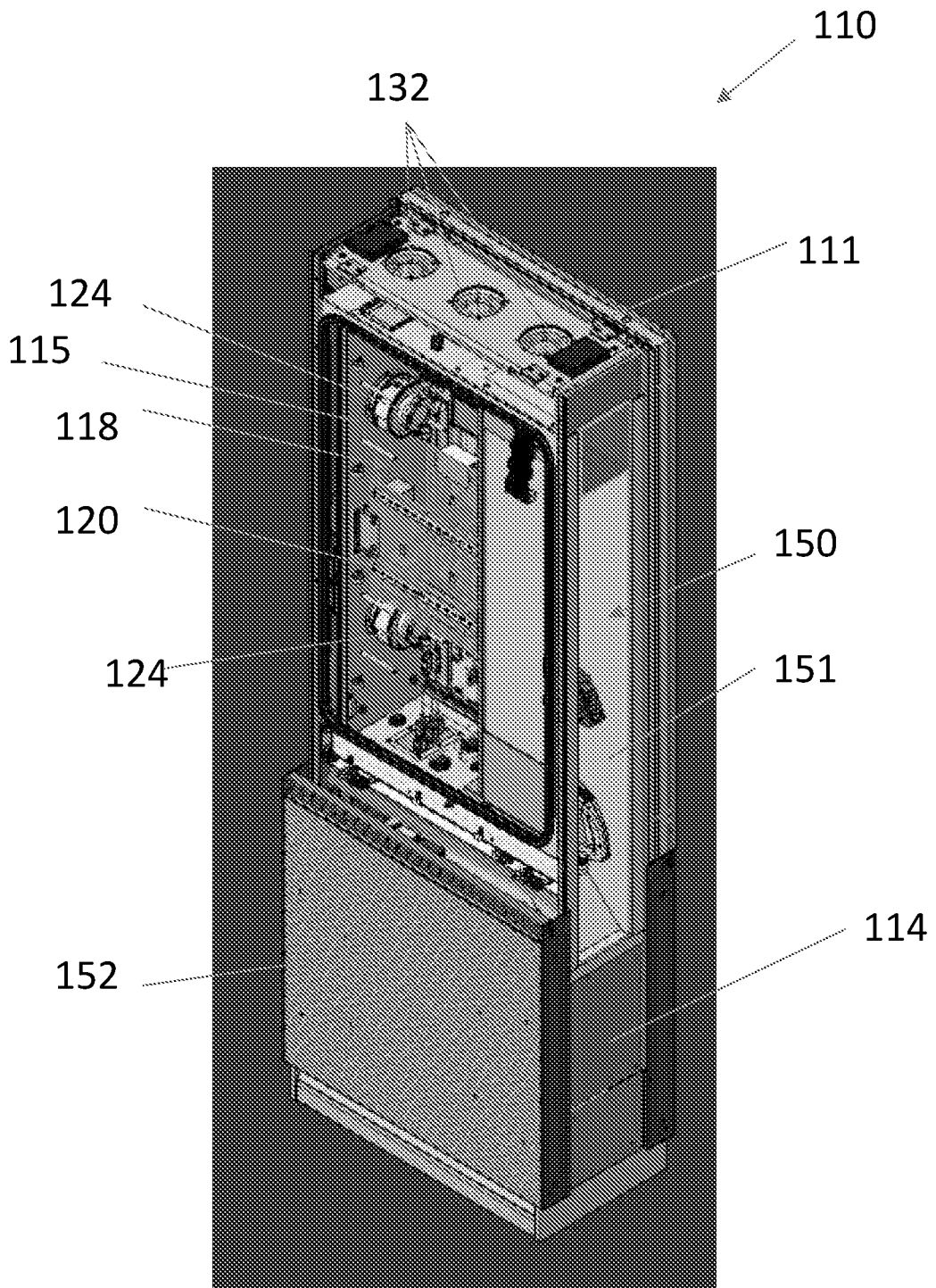

Figure 12

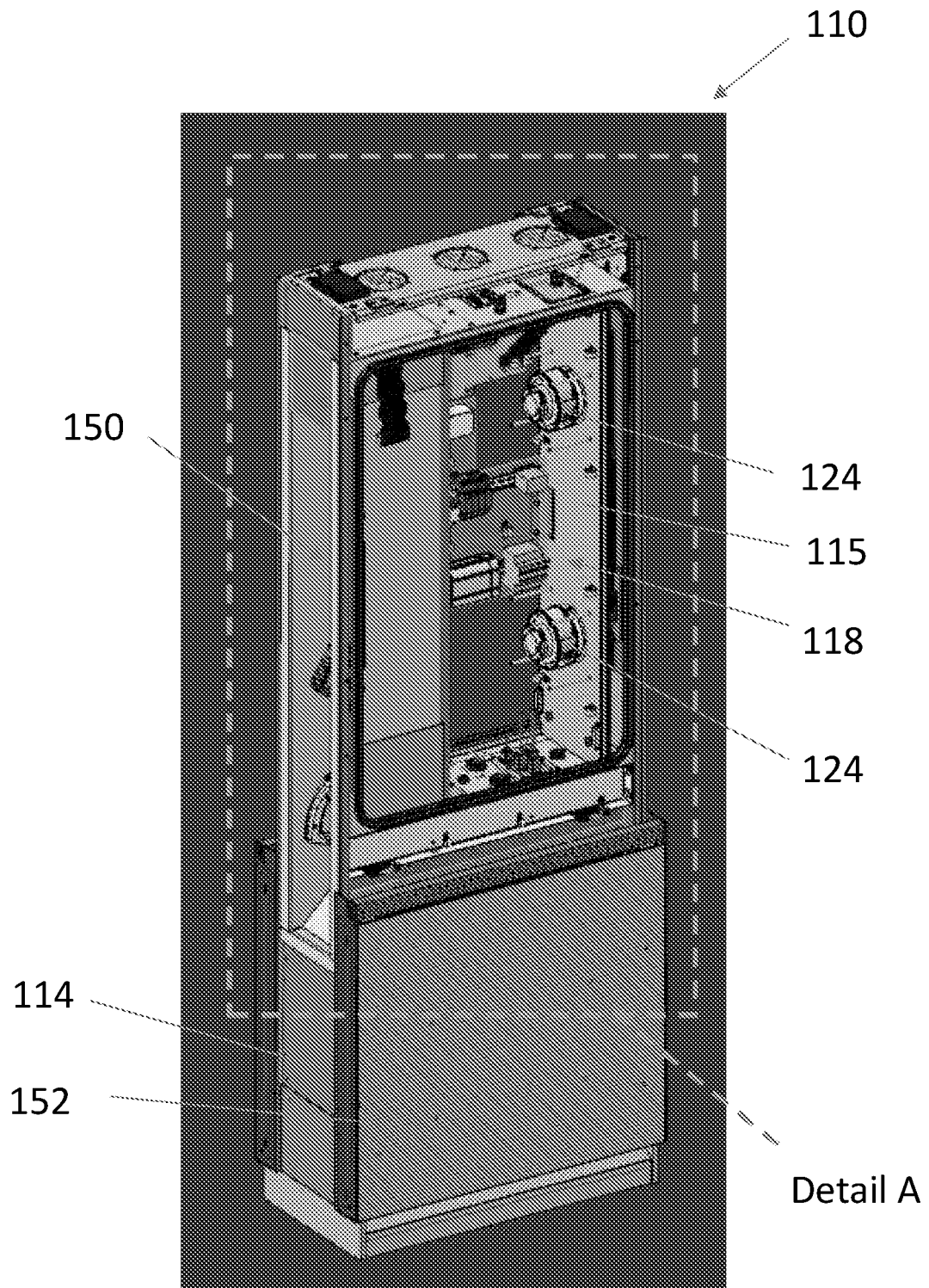

Figure 13

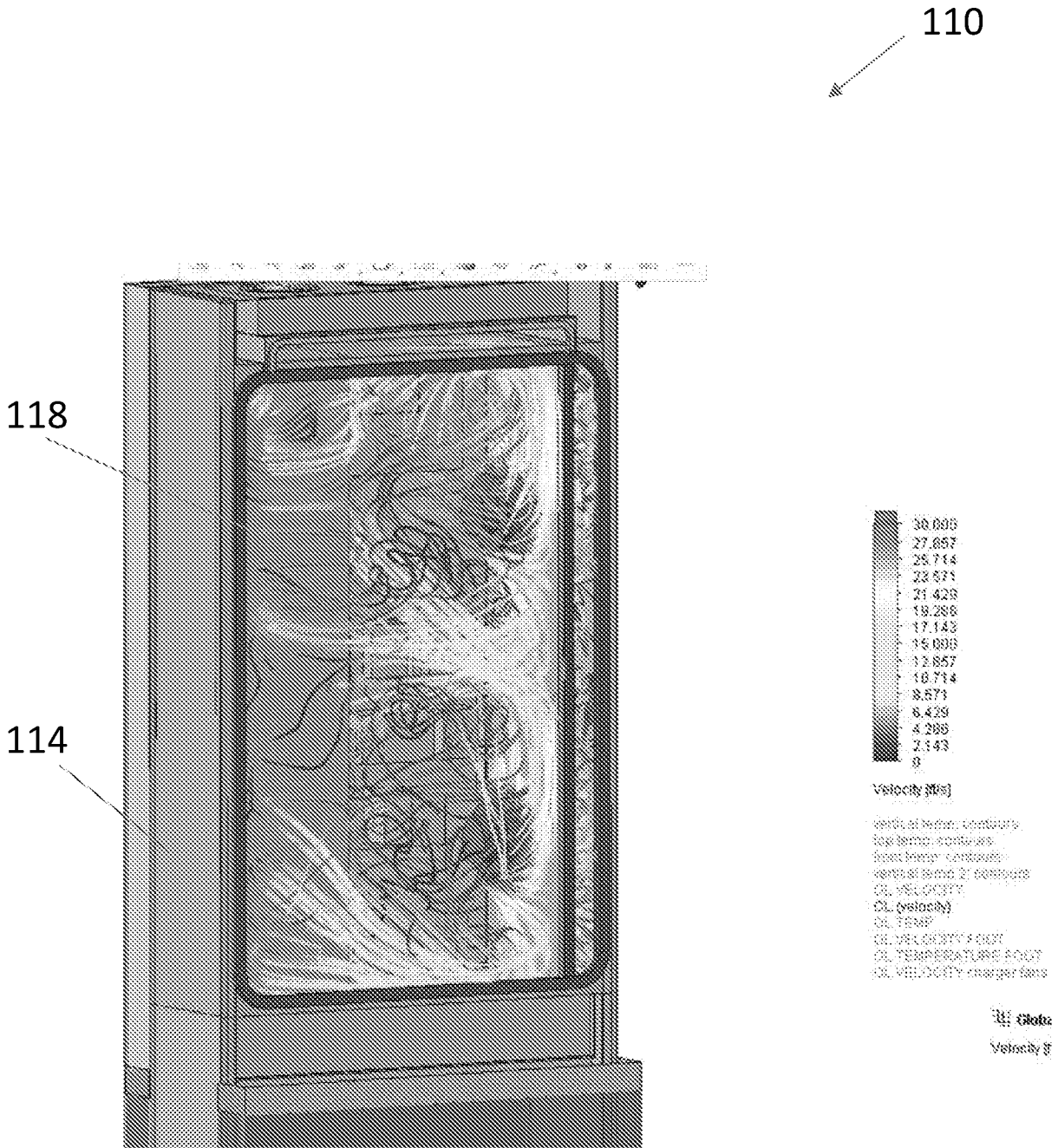

Figure 14

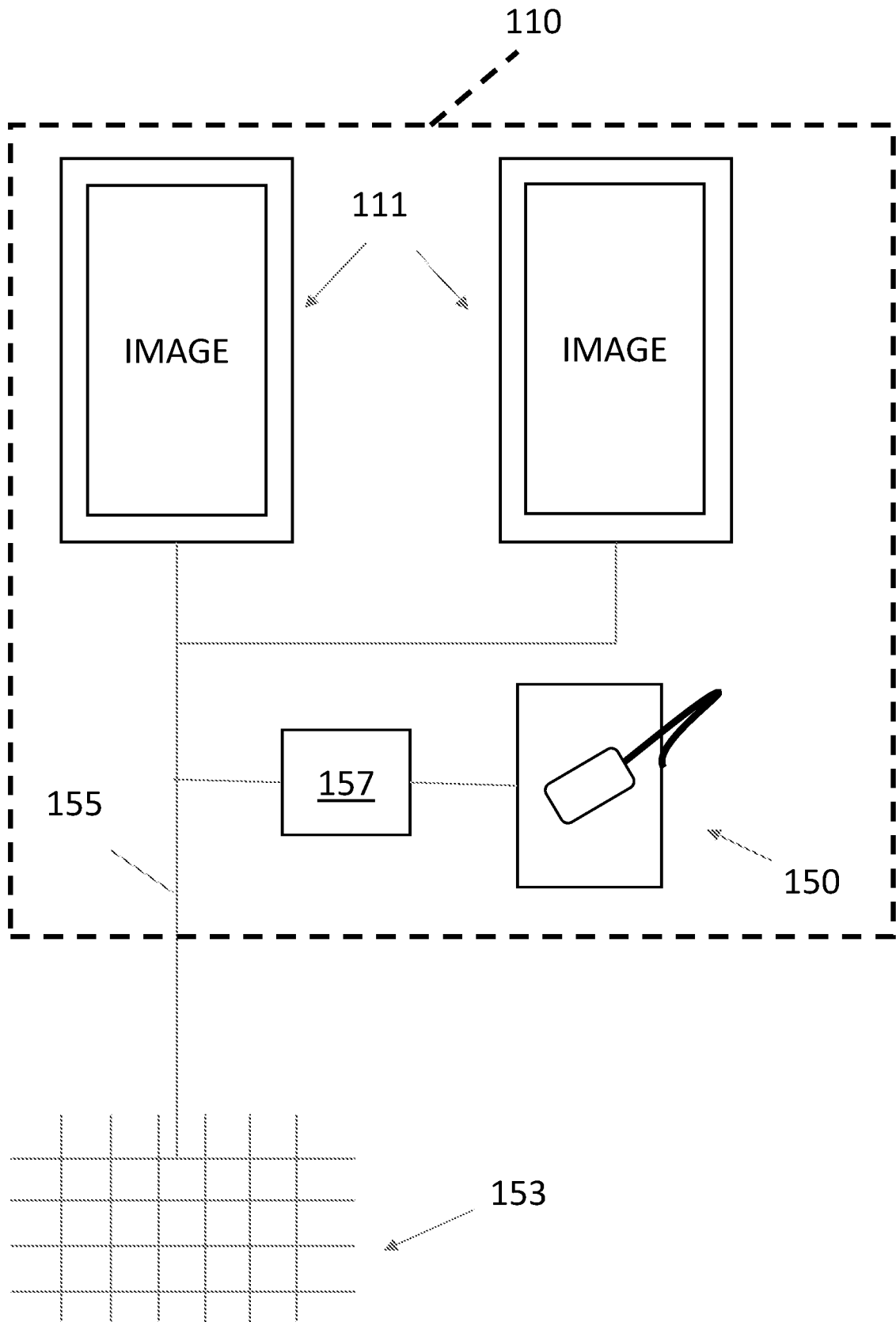

Figure 15A

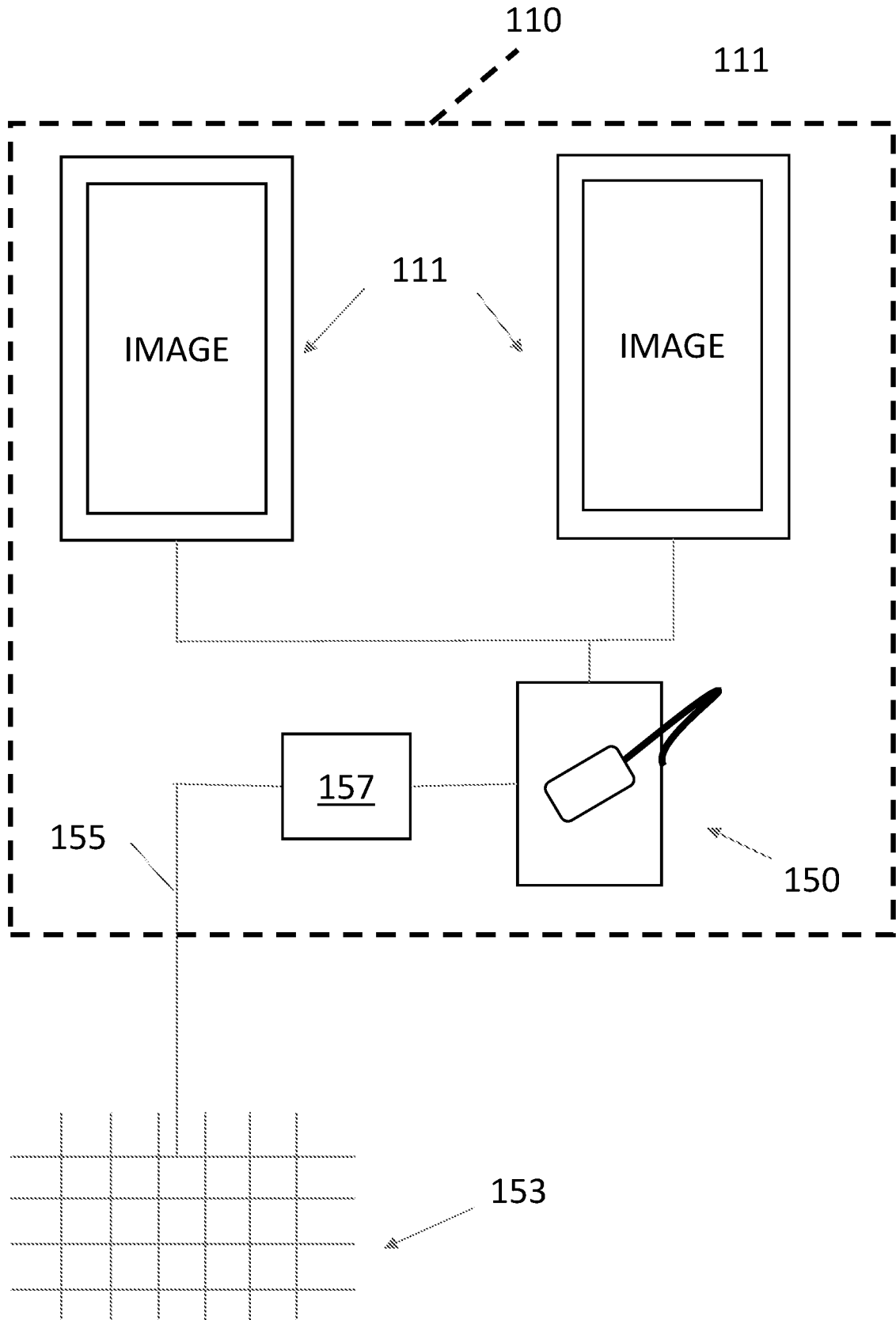

Figure 15B

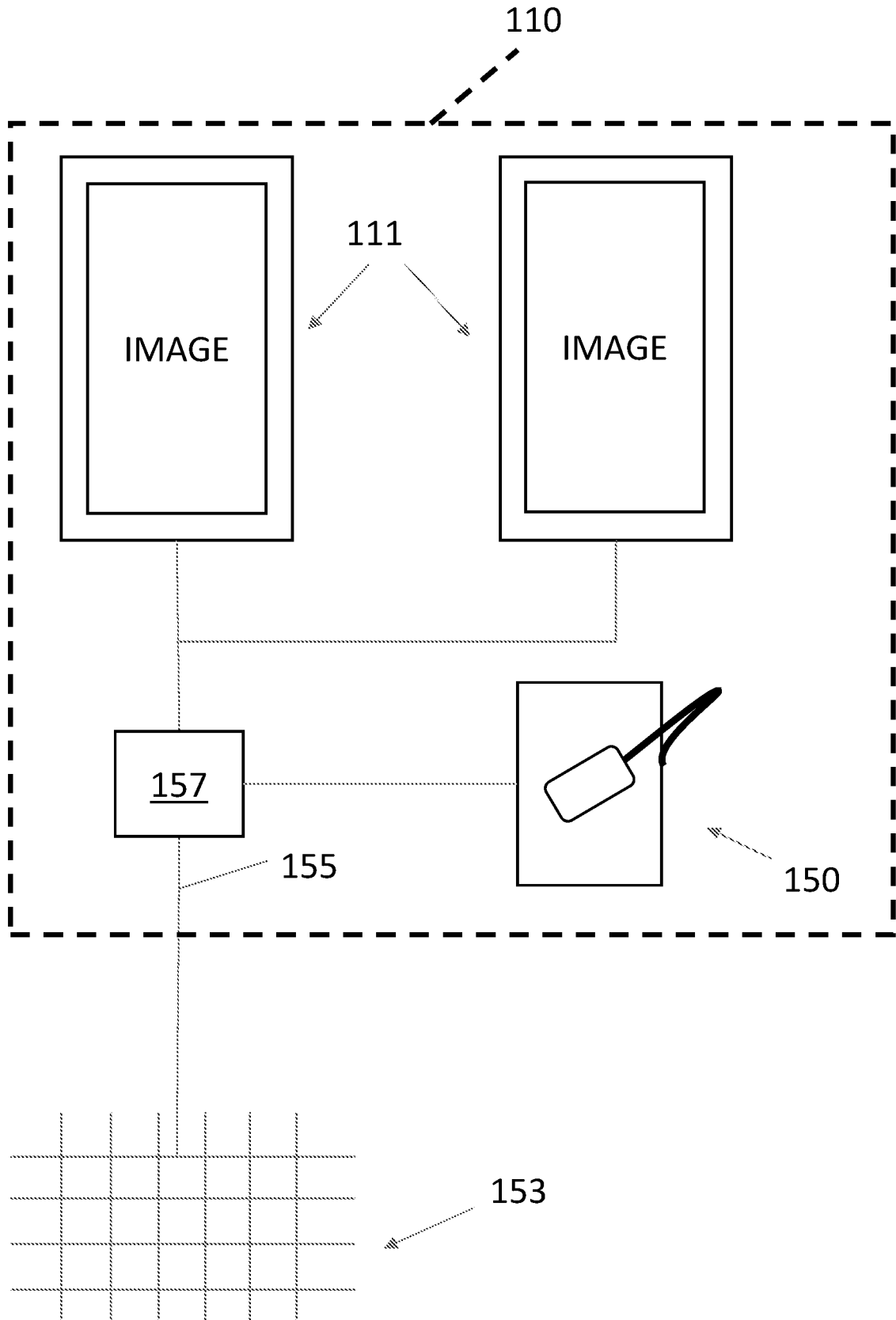

Figure 15C

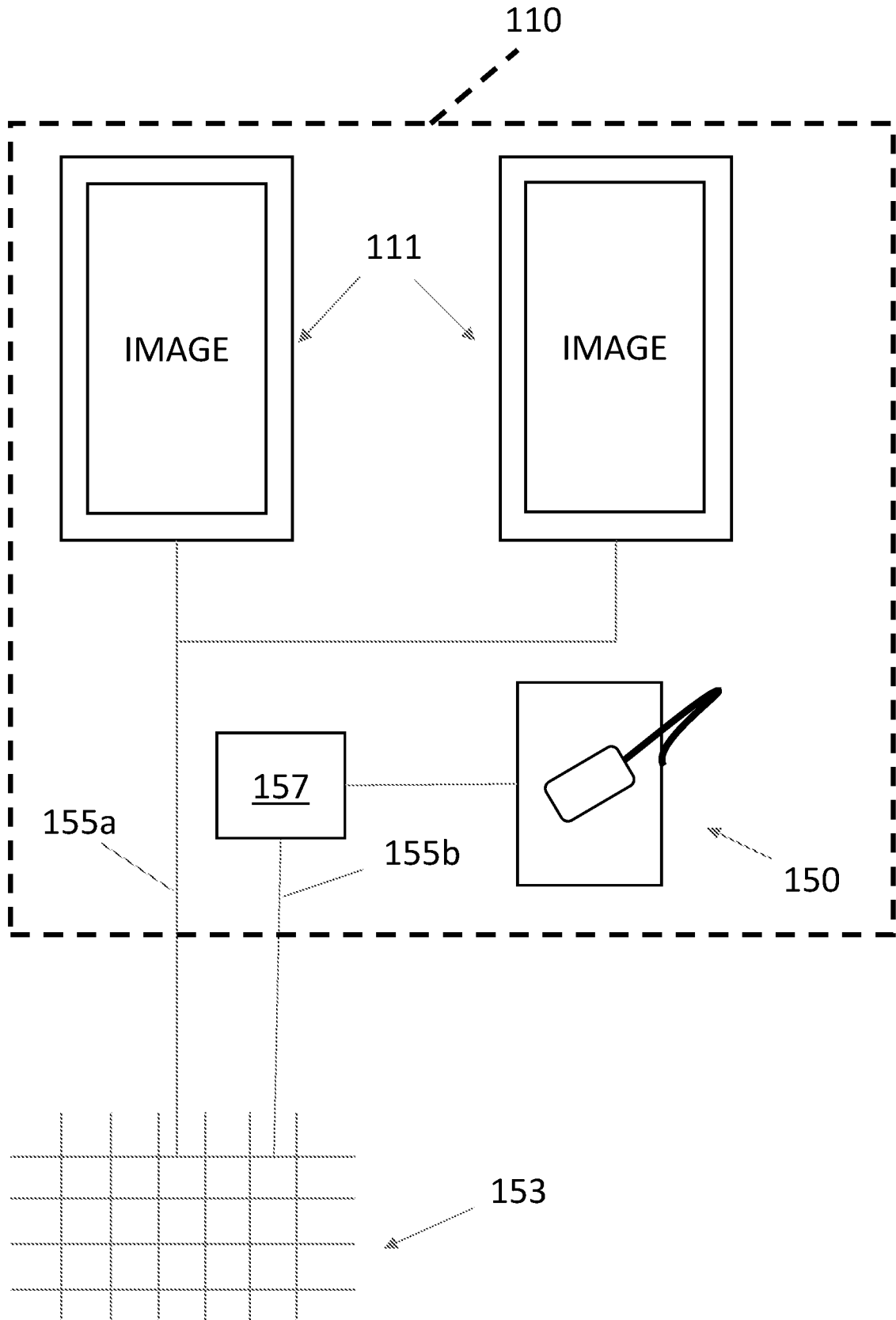

Figure 15D