

O. W. SANFORD.
Dressing Millstones.

No. 17,985.

Patented Aug. 11, 1857.

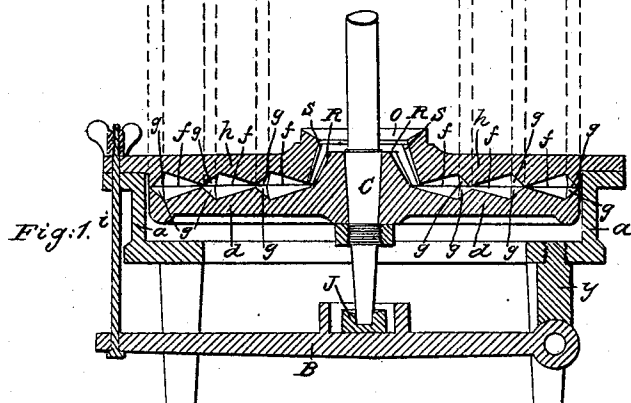
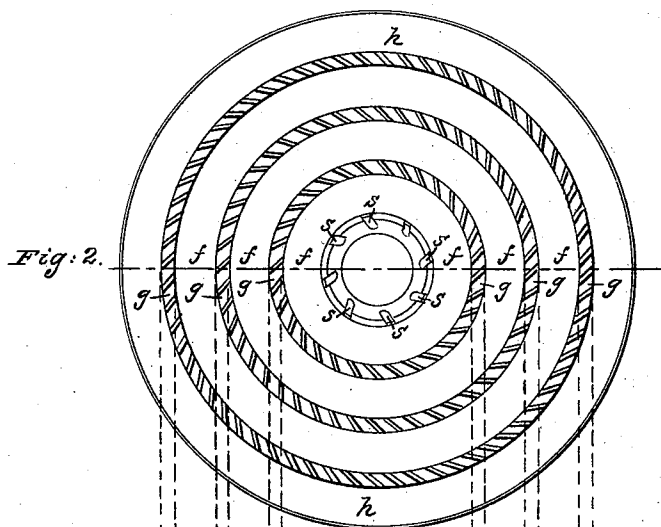
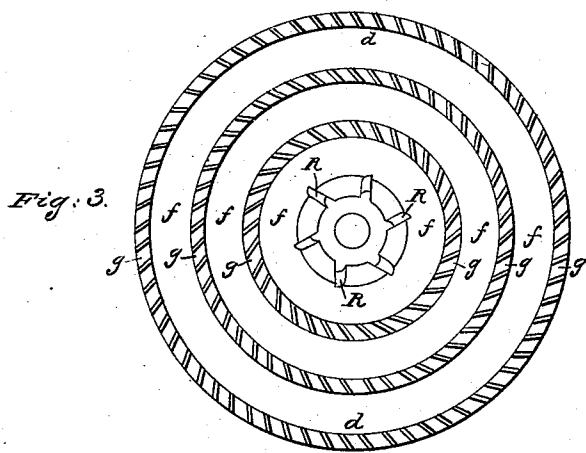

UNITED STATES PATENT OFFICE.

OTIS W. STANFORD, OF CINCINNATI, OHIO.

DRESS OF GRINDING-SURFACES FOR GRAIN-MILLS.

Specification of Letters Patent No. 17,985, dated August 11, 1857.

To all whom it may concern:

Be it known that I, OTIS W. STANFORD, of the city of Cincinnati, county of Hamilton, and State of Ohio, have invented a new and useful Improvement in Mills for Grinding Grain; and I do hereby declare that the following is a full and exact description thereof, reference being had to the accompanying drawings, and made to form part of this specification, and to the letters of reference marked thereon.

Similar letters refer to like parts of the improvement.

The nature of my improvement consists in the mode of constructing the grinding surfaces which are composed of iron or other material and furnished with a series of concentric channels and ridges with the tops or sides of said ridges running together and furnished with suitable teeth or grinding surfaces to perform the grinding required to be done in grinding all or any kind of grains, by which improvement I lessen the power required to grind a given quantity of grain compared with mills where the whole surface of the stone or material is employed for grinding and prevents the heating of the grain in the process of grinding and cheapens the cost of preparing the grinding surface.

To enable others skilled in the art to make and use my improvement, I will proceed to describe its construction and operation by referring direct to the accompanying drawings, of which—

Figure 1 represents a sectional view through the diameter of the mill showing the channels and ridges with the grinding teeth or surfaces. Figs. 2 and 3 are face views of the upper and lower plates employed in the mill and furnished with the concentric channels and ridges as before stated.

The following is a constructive description of the improved mill.

a, a, Fig. 1, represents a cylindrical frame supported on legs or otherwise and furnished with an ordinary bridge-tree *B*, attached to the frame (*a*) at one end of the bridge-tree and the other provided with an adjustable screw *i*, as represented in Fig. 1, for regulating the surfaces of the two plates *d* and *h*, apart for grinding coarse or fine as may be required.

The lower plate *d* is made to revolve by being attached to the shaft (*c*) as represented in Fig. 1, which shaft can receive its

motion by a system of gearing not represented, or its equivalent if desired.

f, f, f, are channels formed as represented or any other shapes that may be desired in the plates *d* and *h*, and *g, g, g*, are a series of teeth cut on the inside of the ridges rising up between the channels. The teeth are cut at a tangent on the plate so that when the two plates are laid together the teeth will cross each other, as is shown by the dotted lines made across the teeth in Figs. 2 and 3, and by this relative position of the teeth on each plate the grain will be reduced more by a cutting than grinding process. And the centrifugal force given to the grain by the motion of the mill will be sufficient to throw the grain across the channels into and between the grinding surfaces and thus from channel to channel and continue to be ground finer and finer by passing between the grinding surfaces *g, g, g*, until it receives its finishing grinding by passing between the outer grinding surface of the two plates which will be adjusted apart to suit the required fineness of grinding that may be wanted from time to time.

R, R, are grinding ribs around the hub of the lower or revolving plate *d, d*, and *S, S*, are similar ribs around the inside of the eye *o*, in the upper or top plate *h, h*, and through which eye the grain passes to be ground from a hopper or other sources if desired.

J, Fig. 1, is a step in a box on the top of the bridge-tree for adjusting the lower part of the spindle (*c*) laterally.

I do not wish to be understood as claiming any particular number of concentric channels *f* and grinding surfaces *g*, nor the shape of said channels and manner of furnishing the grinding surfaces with teeth; but—

What I do claim as my improvement, and desire to secure by Letters Patent, are—

The alternate channels *f* and grinding surfaces (*g*) as represented on the surface of the plates (*d*) and (*h*) when said alternate channels (*f*) and grinding surfaces (*g*) are made concentric with the center of motion given to the plate (*d*) and when arranged with each other and operated in the manner and for the purposes specified in the foregoing specification.

OTIS W. STANFORD.

Witnesses:

BENJAMIN BOFINGER,
P. K. DOMBAUGH,