

C. DANCEL & E. C. SMITH.
 Skiving-Machine.

No. 208,574.

Patented Oct. 1, 1878.

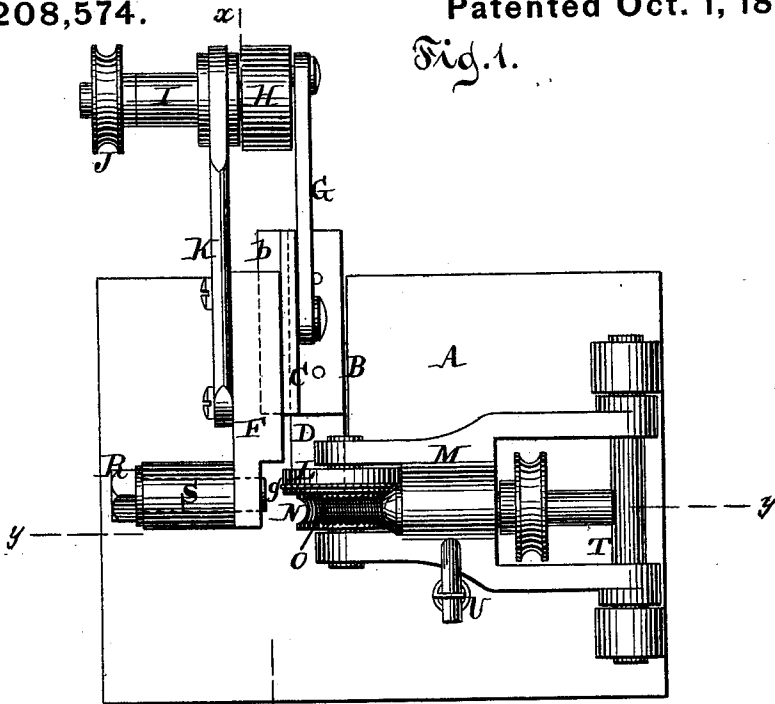

Fig. 1.

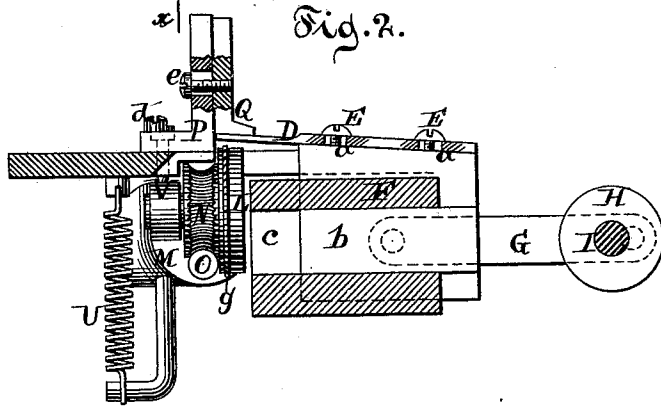

Fig. 2.

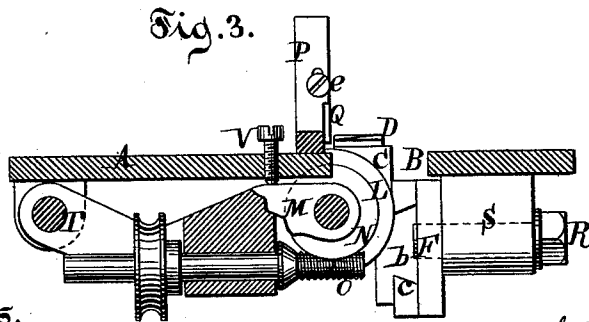

Fig. 3.

Witnesses.
 Chas. Wahlers.

J. H. Wahlers

Inventors.
 Christian Dancel
 Edmond C. Smith.
 by their attys.
 Van Santvoord & Neuff

UNITED STATES PATENT OFFICE

CHRISTIAN DANCEL, OF NEW YORK, AND EDMOND C. SMITH, OF BROOKLYN,
E. D., N. Y.

IMPROVEMENT IN SKIVING-MACHINES.

Specification forming part of Letters Patent No. **208,574**, dated October 1, 1878; application filed
June 20, 1878.

To all whom it may concern:

Be it known that we, CHRISTIAN DANCEL, of the city, county, and State of New York, and EDMOND C. SMITH, of Brooklyn, E. D., in the county of Kings and State of New York, have invented a new and useful Improvement in Skiving-Machines, which improvement is fully set forth in the following specification, reference being had to the accompanying drawing, in which—

Figure 1 represents an inverted plan view of a machine embracing our invention. Fig. 2 is a cross-section thereof in the line *x x*, Fig. 1. Fig. 3 is a longitudinal section of the same in the line *y y*, Fig. 1.

Similar letters indicate corresponding parts.

Our invention relates to machines for skiving leather and like materials; and it consists in certain novel combinations of parts, as hereinafter fully described, and pointed out fully in the claims, a preliminary description being therefore deemed unnecessary.

In the drawing, the letter A designates the bed-plate of our machine, having an opening, B, which extends inward from one of the edges thereof, and in which works the knife-stock C. The top edge of this stock is oblique in the direction of its length, and to such edge is secured the knife D, so that the latter is brought in an oblique position. In the shank of the knife D are formed longitudinal slots *a a*, through which pass set-screws E E, by which the knife is secured to the knife-stock C.

The knife-stock C is provided with a dove-tail, *b*, which is fitted in a groove, *c*, formed in a support, F, so that the knife-stock is adapted to receive a reciprocating motion. This motion is imparted to the knife-stock by means of a pitman, G, which is connected to an eccentric, H, secured on a shaft, I, which is provided with a pulley, J, and mounted in an arm, K, projecting from the knife-stock support F.

The letter L designates a feed-wheel, which is arranged beneath the bed-plate A transversely to the knife D, and in such a manner that it projects slightly above the bed-plate immediately in front of the cutting-edge of the knife. This feed-wheel L is mounted in a yoke, M, and is combined with a worm-wheel, N, and

worm O, from which it receives a revolving motion.

From the bed-plate A rises an edge-gage, P, which is held in position by a screw, *d*, and whose function is to form a guide for the edge of the material to be cut, when the same is fed against the knife D, this edge-gage being so arranged that its face is adjacent to the feed-wheel L.

The edge-gage P carries a top-gage, Q, which is secured thereto by a set-screw, *e*. This top-gage Q is secured to the face of the edge-gage P so that it is brought immediately above the feed-wheel L, and in the proper position to perform its function—namely, to resist the upward pressure of the feed-wheel on the material as it is fed forward. The top-gage Q also prevents the material from being stretched or pulled out of shape.

The feed-wheel L is provided with a single row of teeth, (marked *g*), in contradistinction to being serrated over its whole periphery, so that while the feed-wheel is adapted to move forward the material that may be brought in contact therewith, it allows of moving the material in any direction during the operation of skiving, and consequently our machine is adapted for skiving a piece of leather having a round or curved edge.

The knife-stock support F is mounted on a pivot, R, which extends transversely to the knife D through a hanger, S, fastened to the bed-plate A, and in the example shown this pivot forms also a set-screw, by which the knife-stock support is held in the position to which it may be adjusted. By swinging the knife-stock support F up or down on the pivot R, the knife D can be set to any desired angle.

We arrange the pivot R of the knife-stock support in the plane of the face of the edge-gage P with relation to the direction in which the material moves through the machine, which has the effect of retaining the knife D in one and the same horizontal plane at the face of the edge-gage P when the knife is set to different angles. In other words, the knife D cuts up to the face of the edge-gage in any of its positions.

The yoke M, which supports the feed-wheel,

swings on a pin, T, and it is forced upward by the action of a spring, U, connected to the bottom of the bed-plate A, while its upper position—that is to say, the upper position of the feed-wheel L—is determined by a set-screw, V, passing down through the bed-plate.

What we claim as new, and desire to secure by Letters Patent, is—

1. The combination, in a skiving-machine, of an oblique knife, a reciprocating knife-stock, a feed-wheel arranged transversely to the plane of the knife, an edge-gage situated adjacent to the feed-wheel, for guiding the material against the knife, and a top-gage situated above the feed-wheel, to resist the upward pressure thereof on the material as it is fed forward, substantially as described.

2. The combination, in a skiving-machine, of a feed-wheel having a single row of teeth, to permit of turning the material as it is fed forward, with an oblique knife, a reciprocating knife-stock, an edge-gage, and a top-gage, all adapted to operate substantially as described.

3. The combination, in a skiving-machine, of an oblique knife, a reciprocating knife-stock, and a knife-stock support which is pivoted transversely to the knife, to permit of chang-

ing the angle of the latter, substantially as described.

4. The combination, in a skiving-machine, of an oblique knife, a reciprocating knife-stock, an edge-gage for guiding the material against the knife, and a knife-stock support which is pivoted in a plane corresponding to the face of the edge-gage relatively to the direction in which the material is fed, so that the plane of the knife remains unchanged at the point of the edge-gage when the knife is set to different angles, substantially as described.

5. The combination, in a skiving-machine, of a feed-wheel, a hinged yoke for supporting the feed-wheel, a spring arranged to force said yoke upward, and an adjustable stop for regulating the upper position of the yoke, substantially as described.

In testimony that we claim the foregoing we have hereunto set our hands this 13th day of June, 1878.

CHRISTIAN DANCEL.
EDMOND C. SMITH.

Witnesses:

W. HAUFF,
E. F. KASTENHUBER.