

Nov. 18, 1924.

1,516,214

V. SÉVIAN

MEANS FOR PROTECTING INFLAMMABLE LIQUIDS STORED IN BULK FROM FIRE

Filed July 17, 1922

5 Sheets-Sheet 1

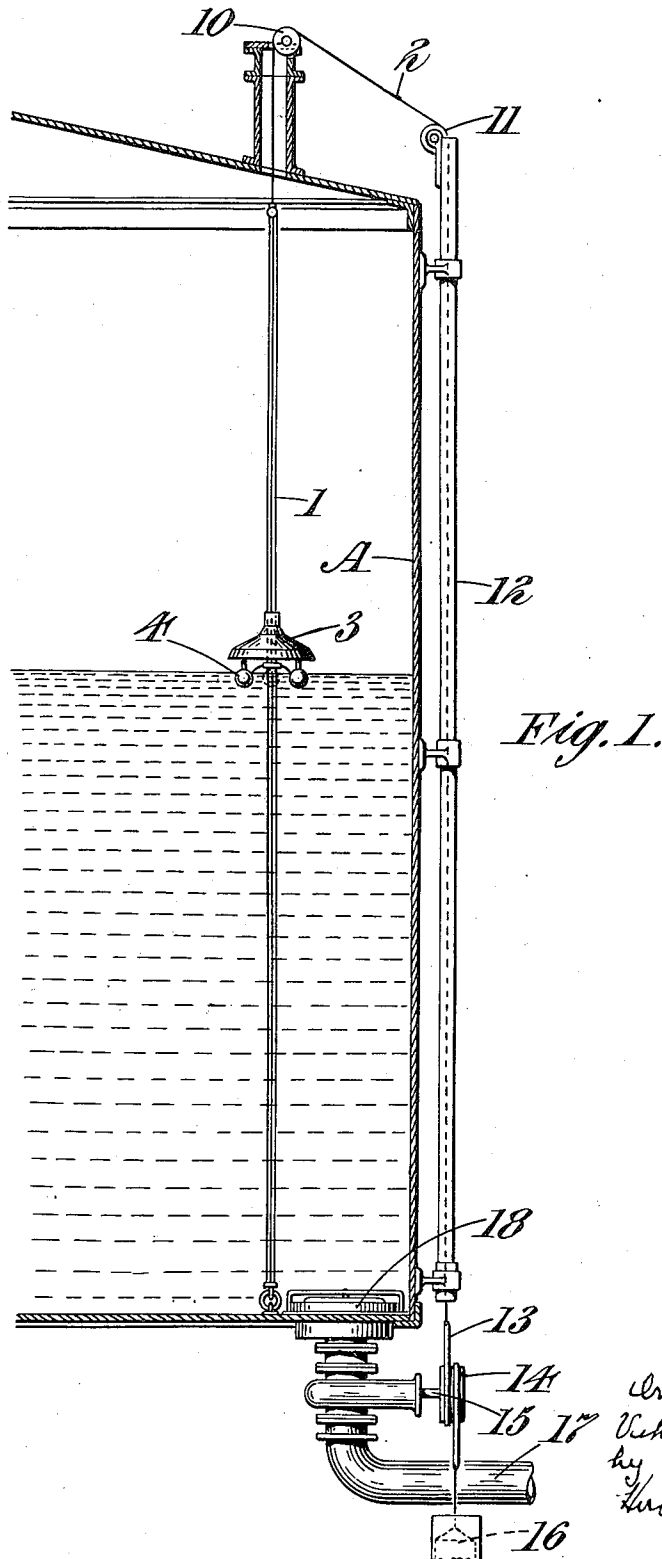

Fig. 1.

Inventor:-  
V. Sévian  
by  
Hubert Pack  
atty

Nov. 18, 1924.

1,516,214

V. SÉVIAN

MEANS FOR PROTECTING INFLAMMABLE LIQUIDS STORED IN BULK FROM FIRE

Filed July 17, 1922

5 Sheets-Sheet 2

Fig. 2.

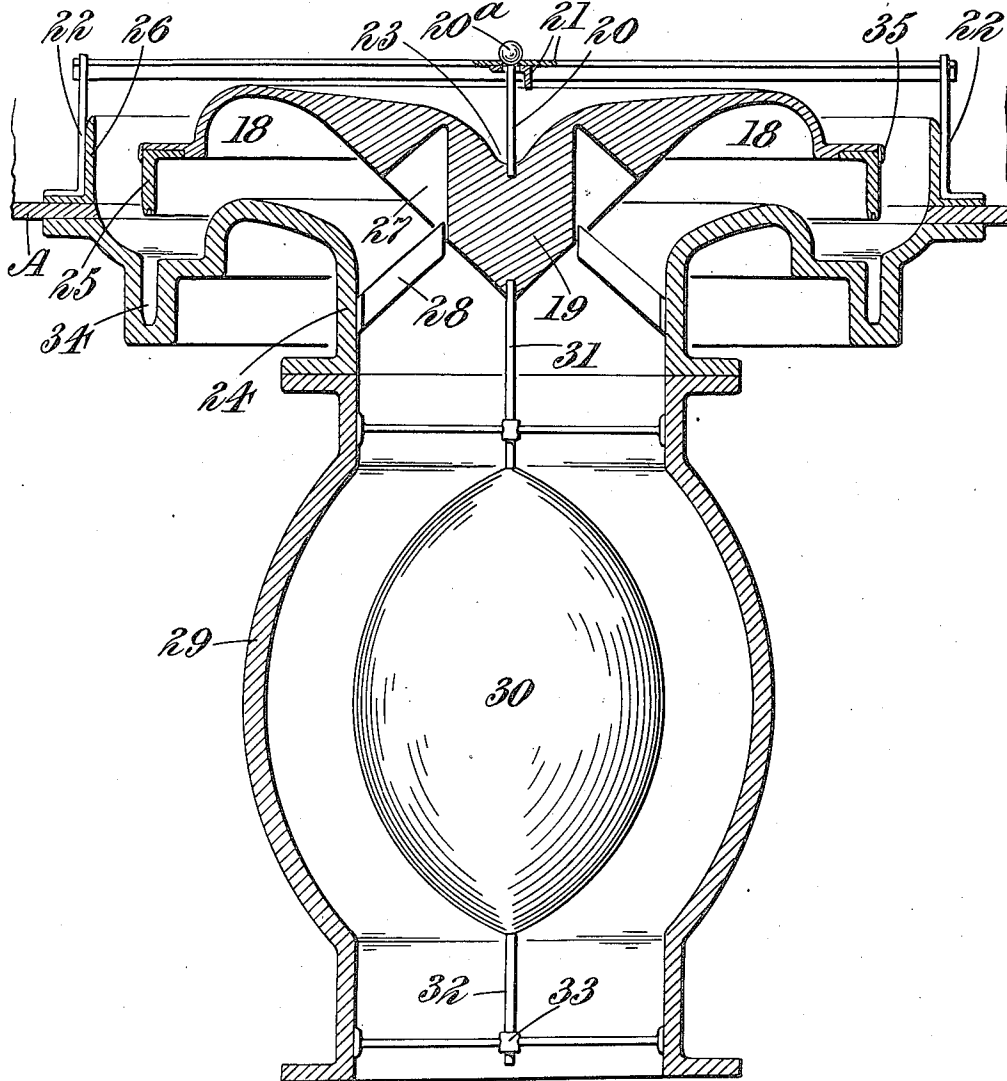

Inventor:-  
Valre Sévian  
by Hubert Peck  
atty

Nov. 18, 1924.

1,516,214

V. SEVIAN

MEANS FOR PROTECTING INFLAMMABLE LIQUIDS STORED IN BULK FROM FIRE

Filed July 17, 1922

5 Sheets-Sheet 3

*Fig. 3.*

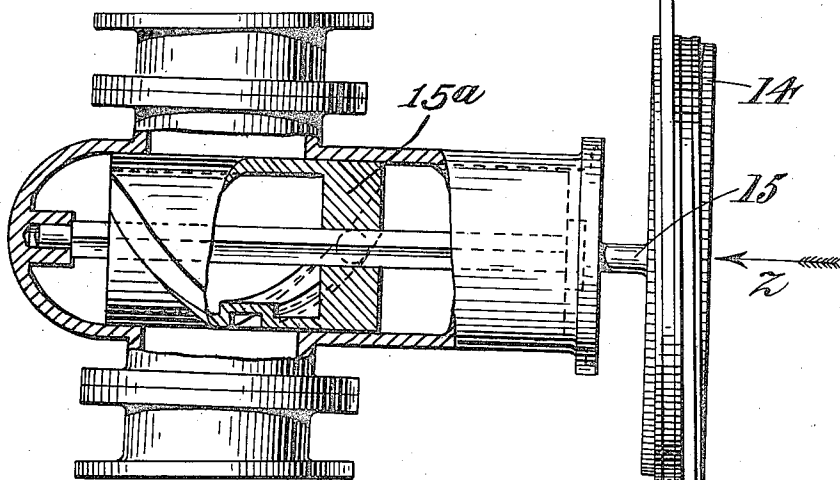

*Fig. 4.*

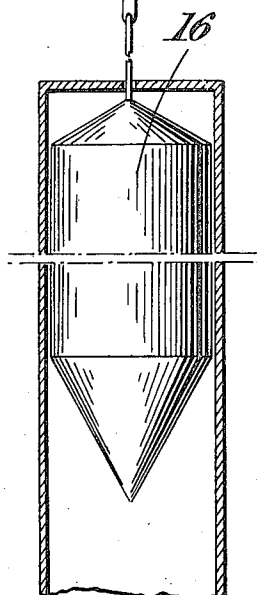
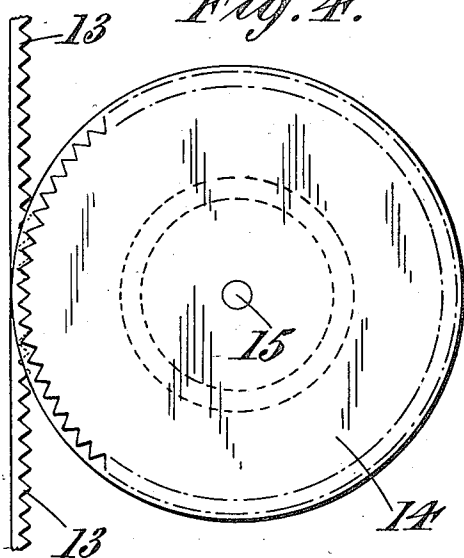

Inventor:-  
Vahé Sévian  
by Hubert Eckally

Nov. 18, 1924.

1,516,214

V. SÉVIAN

MEANS FOR PROTECTING INFLAMMABLE LIQUIDS STORED IN BULK FROM FIRE

Filed July 17, 1922

5 Sheets-Sheet 4

*Fig. 5.*

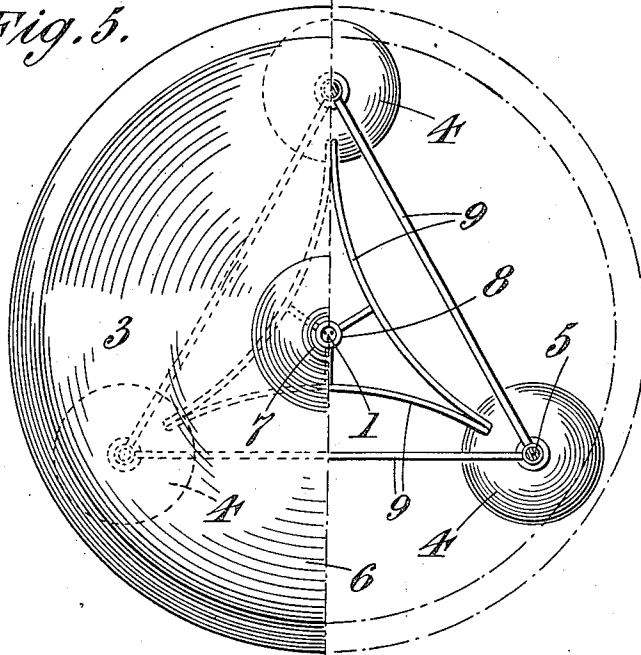

*Fig. 6.*

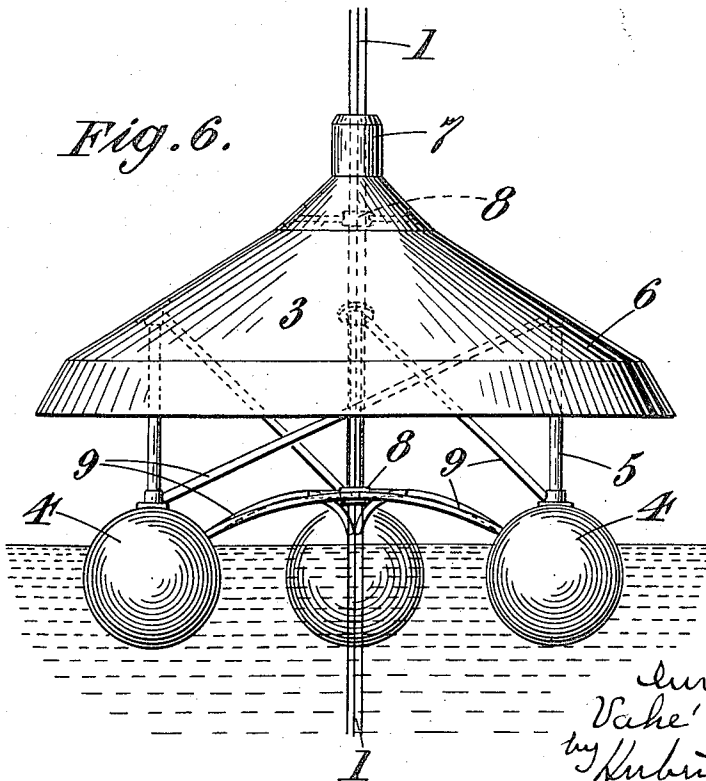

*Inventor -  
Vake' Sevian  
by Hubert P. Beck  
att'y*

Nov. 18, 1924.

1,516,214

V. SÉVIAN

MEANS FOR PROTECTING INFLAMMABLE LIQUIDS STORED IN BULK FROM FIRE

Filed July 17, 1922

5 Sheets-Sheet 5

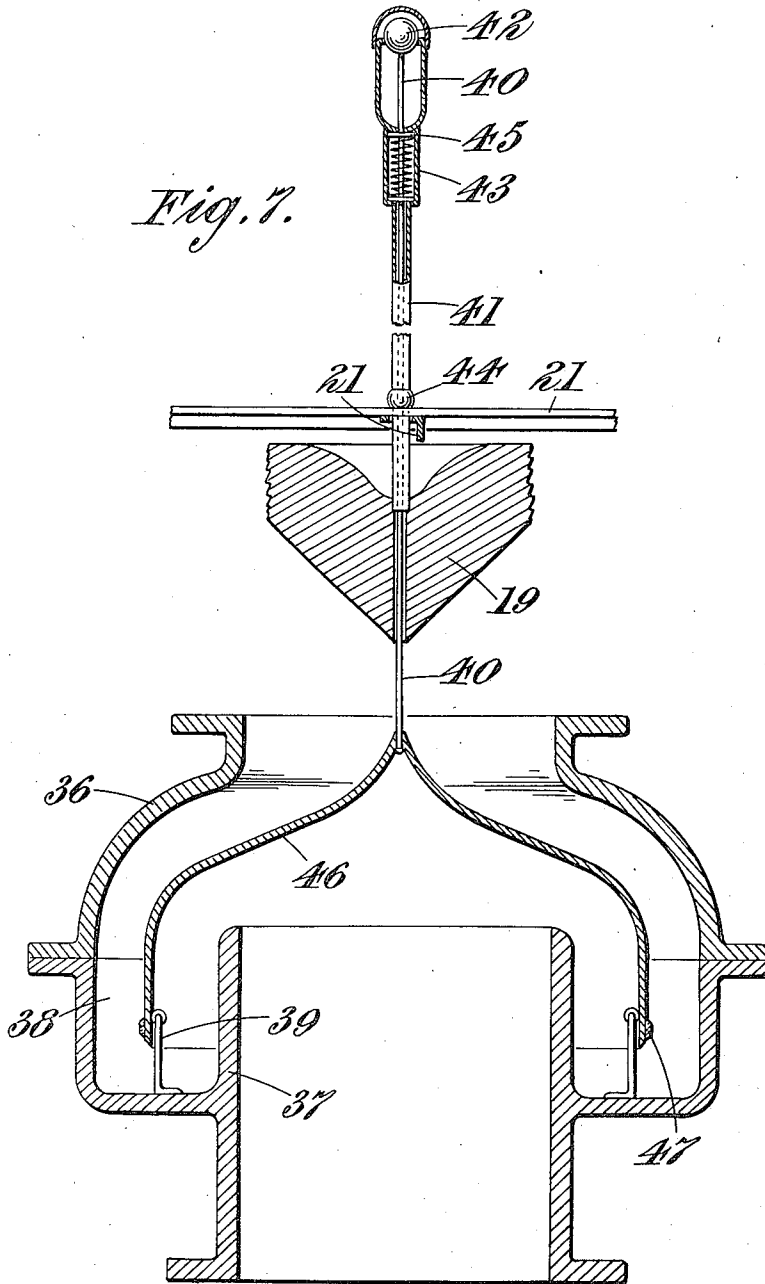

Inventor:-  
Vahé Sévian  
by Herbert Peck  
atty

# UNITED STATES PATENT OFFICE.

VAHÉ SÉVIAN, OF BAGDAD, TURKEY.

MEANS FOR PROTECTING INFLAMMABLE LIQUIDS STORED IN BULK FROM FIRE.

Application filed July 17, 1922. Serial No. 575,734.

*To all whom it may concern:*

Be it known that I, VAHÉ SÉVIAN, Ottoman subject, and resident of Bagdad, Turkey, have invented new and useful Improvements in Means for Protecting Inflammable Liquids Stored in Bulk from Fire, of which the following is a specification.

This invention relates to means for the protection of inflammable liquids, such as petrol, stored in bulk from fire and for the extinguishing of fires in such liquids, and the improvements have for their object means which, on the occurrence of a fire, automatically come into action and place the tank or other receptacle in which the liquid is stored in bulk in connection with a subsidiary reservoir or other receptacle into which the liquid that is not in combustion is run, the flow of the liquid being interrupted by other automatically acting means when the level of the burning liquid approaches the connection between the two receptacles.

Means for the purpose specified, according to this invention, comprises the combination of a main tank or other bulk storage receptacle, a subsidiary reservoir or receptacle, a connection between said tank and reservoir, a valve in said connection and controlling means for the valve comprising means to close the valve and means to hold the valve open against said first mentioned means and comprising a fusible member.

Means for the purpose specified further comprises, according to this invention, the combination with the parts set out in the preceding paragraph, of a secondary and normally open valve in said connection and means to maintain said valve in its open attitude and comprising a fusible member.

In order that the invention, the nature and object of which have been set forth, may be clearly understood and readily be put into practice, reference will now be made to the accompanying drawings on which an embodiment is illustrated.

Fig. 1 being a part sectional view of the storage tank A with protection means;

Fig. 2 a sectional view of the secondary valve;

Fig. 3 a view to a larger scale than Fig. 1 of the main controlling valve;

Fig. 4 a view looking in the direction of the arrow Z, Fig. 3;

Figs. 5 and 6 a plan view and an elevation, respectively, to a larger scale than Fig.

1, of the combined float and flame concentrator; and

Fig. 7 a sectional view of a part which is substituted in certain circumstances for the lower part of the means shown in Fig. 2.

Referring to Fig. 1.

Two or more wires 1 of lead or other metal fusing at a comparatively low temperature and not affected prejudicially by any chemical action of the inflammable liquid stored in the tank A, are arranged parallel to one another a small distance apart and extend from the bottom of the tank A, to which they are fixed, to the upper end thereof where they are connected to the one end of a wire 2 of iron, steel or other metal. Mounted on the wires 1 and freely movable up and down in relation thereto is a float 3 which rises or falls with alteration in the level of the liquid in the tank A. The float 3 is such that in addition to the function indicated by its name it, in cases of fire, directs flames in the vicinity thereof on to the wires 1 and ensures that they shall fuse promptly and release the means they control to permit the discharge of inflammable liquid not in a state of combustion from the tank to the subsidiary reservoir. The float 3 comprises, as shown in Figs. 5 and 6, a plurality of hollow balls, 4, a member 6 of truncated conical shape and rods 5 connecting the balls 4 and member 6 and supporting the latter above the balls. The member 6 is made of asbestos and on its upper part is mounted a tube 7 which acts as a funnel and causes any flames that enter the member 6 to be drawn therethrough and the heat concentrated on the wires 1 which are therefore caused to fuse promptly. The member 6 is maintained in a horizontal attitude and the float 3 guided in its up and down movements by guide rings 8 which are connected by a framework 9 with the parts of the float.

The wire 2 passes out of the tank A as shown in Fig. 1 and when clear thereof is led over a pulley 10 to a pulley 11 from which it passes downward exteriorly of the tank A: the lower end of the wire 2 is connected to a flexible toothed steel band 13 which is wrapped one or more times around a toothed wheel 14 mounted on the end of a valve operating spindle 15 of a rotary valve 15<sup>a</sup>. The other end of the band 13 carries a weight 16. The weight 16 tends to impart rotation

to the valve spindle 15 and therefore to the valve thereon 15<sup>a</sup>, but such rotary motion is prevented so long as the wires 1 are intact. The valve 15<sup>a</sup> on the spindle 15 is in a pipe 5 17 which connects the tank A with the subsidiary reservoir. Severance of the wires 1 thus places the tank A in connection with the subsidiary reservoir.

To reduce the effects of expansion due to 10 changes of temperature on the wires 1, 2, the pulley 11 is mounted on the upper end of a tube 12 which is anchored at its other end. The tube 12 acts also as a guide and protector to the wire 2 which passes there- 15 through. The valve 15<sup>a</sup> in pipe 17 is also so constructed that the first part of its opening movement does not connect the tank A and the subsidiary reservoir: any alteration in 20 length of wires 1 and 2 which is not counteracted by expansion of tube 12 is thus compensated for.

The bottom of the tank A is also provided with a secondary valve 18 by which the tank A is automatically disconnected from 25 the subsidiary reservoir when the level of the liquid approaches the bottom of the tank and there is danger that hot or burning liquid may pass through the pipe 17 and ignite the liquid that has passed to the sub- 30 sidiary reservoir. The valve 18 comprises, as shown in Fig. 2, a weighted valve member 19, and a pipe section 24 which is mounted on the upper end of the pipe 17 either 35 directly or indirectly through another pipe section 29. The valve member 19 at its lower part is formed to co-operate with and to seat on the upper end of the pipe section 24. The valve member 19 is suspended by 40 a fusible wire 20 at the intersection of two bars or angle irons 21 which are carried by standards or uprights 22 mounted on the floor of the tank A. The fusible wire 20 passes through a hole in the bars or angle 45 irons 21 and has at its outer end a fusible knob 20<sup>a</sup> by which it and the valve member 19 are supported. When a fire occurs and the liquid is drawn off through the pipe 17, its level approaches the bars 21 on reaching 50 which the heat fuses the knob 20<sup>a</sup> and wire 20 with the result that the member 19 drops and closes the upper end of the pipe section 24.

The upper face of the valve member 19 is preferably inclined towards the centre to 55 form a cavity or depression 23 to contain a certain quantity of liquid, the flames from which will be concentrated on the wire 20 and ensure its fusion.

Surrounding the opening in the bottom 60 of the tank A in which the pipe section 24 is secured is an upstanding flange 26 which, when the level of the liquid reaches its upper edge, presents an obstruction and prevents the further flow of liquid to the pipe 17 if 65 the valve member 19 has not by that time

closed on its seat. The perimeter of the valve member 19 also has mounted on it a depending flange 25 which when the valve member 19 moves down on to its seat enters 70 a groove 34 in the pipe section 24. The flange 25 is surrounded at its upper part by a fusible metal ring 35 which will fuse and make a joint between the valve member 19 and its seat.

The valve member 19 has on its lower 75 face grooves 27 in which engage plates 28 mounted interiorly of the pipe section 24: the plates 28 act as guides to the valve member 19 during its descent.

When the pipe section 24 is of small di- 80 ameter, the mass of the valve member 19 may not be sufficient to ensure its fall: in such case, a pipe section 29 is inserted between the pipe section 24 and the pipe 17 and this pipe section 29 contains a weight 30 which 85 is suspended by a bar 31 from the valve member 19. To prevent any play of the weight 30 it has an extension 32 at its lower end which passes through a guide ring 33 supported from the wall of the tube section 90 29.

When the means herein described is ap- 95 plied to tanks in which liquid will be stored that possess the property of rapid combustion or generate explosive gases, there are substituted for the pipe section 29 and contained weight 30, the parts illus- 100 trated in Fig. 7. These comprise a bell 46 contained within an appropriately formed member 36 which with a tube 37 constitutes 105 a channel 38. The mouth of the bell 46 is contained in this channel 38 and is guided in its movements by angle irons 39.

The bell 46 is carried by a bar 40 which 110 passes through the valve member 19 and above the said member is contained in a tube 41 which carries the valve member 19 and which passes through the bars 21. The tube 41 is supported by the bars 21 by means 115 of a fusible ring or ball 44. The upper end of the tube 41 is of enlarged diameter and in the open end thereof is seated a fusible metal ball 42 to which the upper end of the rod 40 is connected. The upper part of the tube 41 also contains a spring 43 upon which 120 rests a plate 45 connected with the rod 40.

When on the occurrence of a fire, the heat 125 acts on the ball 42, which fuses and allows the bell to drop. The upper end of the tube 41 is closed by the plate 45 which in its descent compresses the spring 43; the compression of the spring 43 exerts a downward pressure on the valve member 19 130 through the tube 41 and when the flames reach and melt the ring or ball 44 assists the valve member 19 in its downward movement.

All round the mouth of the ball 46 is a fusible metal ring 47 which when melted 135 will ensure the tightness of the joint made

between the bell and the bottom of the channel 38.

What I claim is:—

1. Means for the purpose specified, comprising a bulk storage receptacle having a discharge line therefrom, a valve in the discharge line, operating means for said valve including a weighted connection operatively coupled thereto and adapted to actuate the valve to position opening the discharge line, and means for normally maintaining the valve in position closing the discharge line, comprising a fusible connection anchored at one end to and extending through the receptacle and at the opposite end coupled to the weighted valve operating connection to maintain the valve closed.

2. Means for the purpose specified, comprising a bulk storage receptacle having a discharge therefrom, a valve controlling said discharge, actuating means for said valve normally tending to open the same, and means for maintaining said valve closed, comprising a fusible element anchored at one end to and extending through the receptacle and coupled at the opposite end to the valve actuating means, whereby upon fusion of said element extending through the receptacle the valve actuating means is released to close the valve.

3. Means for the purpose specified, comprising a bulk storage receptacle having a discharge therefrom, a valve controlling said discharge, operating means for said valve normally tending to open the same, means for maintaining said valve closed, comprising a fusible element anchored at one end to and extending in vertically disposed position through the receptacle, and coupled at the opposite end to the valve operating means to maintain the same in position closing the valve, and flame concentrating means mounted and freely movable longitudinally along said fusible element.

4. Means for the purpose specified, comprising a bulk storage receptacle having a discharge therefrom, a valve controlling said discharge, operating means for said valve normally tending to open the same, means for maintaining said valve closed against the action of said operating means, comprising a fusible element anchored at one end to and extending in vertically disposed position through the receptacle, and coupled at the opposite free end to the valve operating means to maintain the same in position closing the valve, and flame concentrating means including a float mounted and freely movable longitudinally along the fusible element by variations in the level of a liquid in the receptacle.

5. Means for the purpose specified, comprising, in combination, a bulk storage receptacle having a discharge therefrom, a

valve controlling said discharge, operating means for said valve normally tending to open the same, means for maintaining said valve closed against the action of said operating means, comprising a fusible element anchored at one end to and extending through said receptacle, and coupled at the opposite free end to the valve operating means to maintain the same in position closing the valve, and a secondary valve controlled discharge separate from and wholly independent of said first mentioned discharge, including a drop valve, and a fusible member normally maintaining the drop valve open, said drop valve so positioned as to function after operation of said first mentioned valve.

6. Means for the purpose specified, comprising in combination, a bulk storage receptacle having a discharge line from the bottom thereof, a valve in said line on the exterior of the receptacle operating means for said valve normally tending to open the same, means for maintaining said valve closed against the action of said operating means, comprising a fusible element anchored at one end to and extending through said receptacle and coupled at the opposite free end to the valve operating means to maintain the same in position closing said valve, a second valve mounted in the discharge line within the receptacle entirely independently of said exterior valve, and a fusible link normally maintaining the second valve open, said second valve adapted to function and close the discharge after operation of said exterior valve to open position.

7. Means for the purpose specified, comprising in combination, a bulk storage receptacle having a discharge line therefrom, a valve in said line on the exterior of the receptacle, operating means for said valve normally tending to open the same, means for maintaining said valve closed against the action of said operating means, comprising a fusible element anchored at one end to and extending through the receptacle, and coupled at the opposite free end to the valve operating means to maintain the same in position closing said valve, a second valve in said discharge line on the interior of said receptacle, a pipe section in the discharge line forming a seat for said valve, a fusible element normally holding said interior valve off the seat therefor, and a weight attached to said valve and contained within said pipe section, said interior valve operable to close the discharge line only after operation of said exterior valve to open said line.

Dated this sixth day of June, 1922.

VAHÉ SÉVIAN.