

Oct. 10, 1961

A. MORENO
ROTARY TYPE WINDOWS

3,003,201

Filed April 14, 1960

2 Sheets-Sheet 1

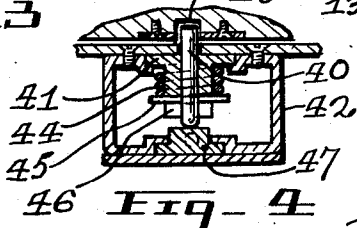
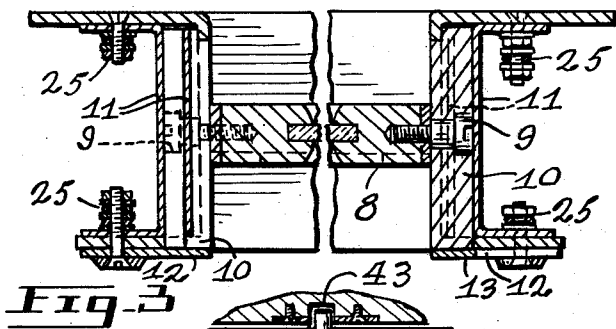
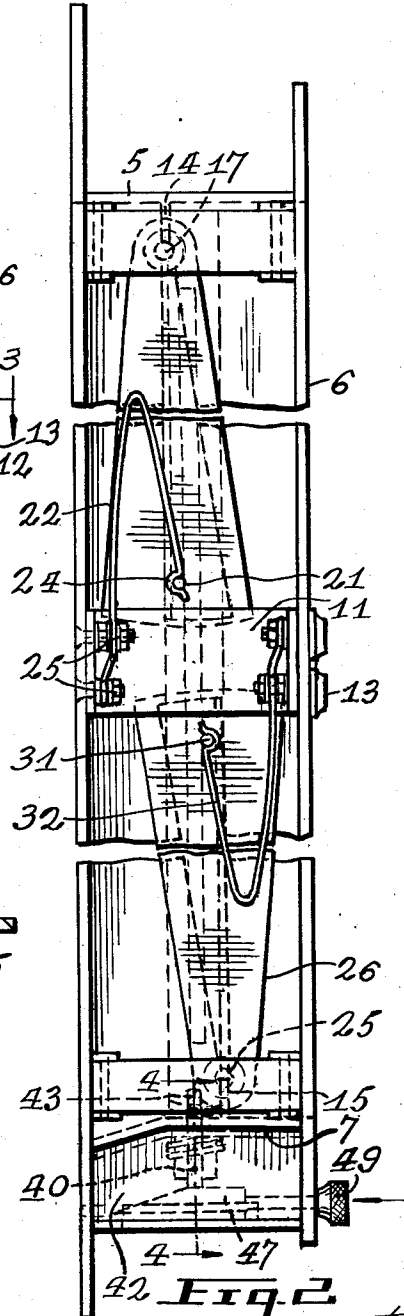
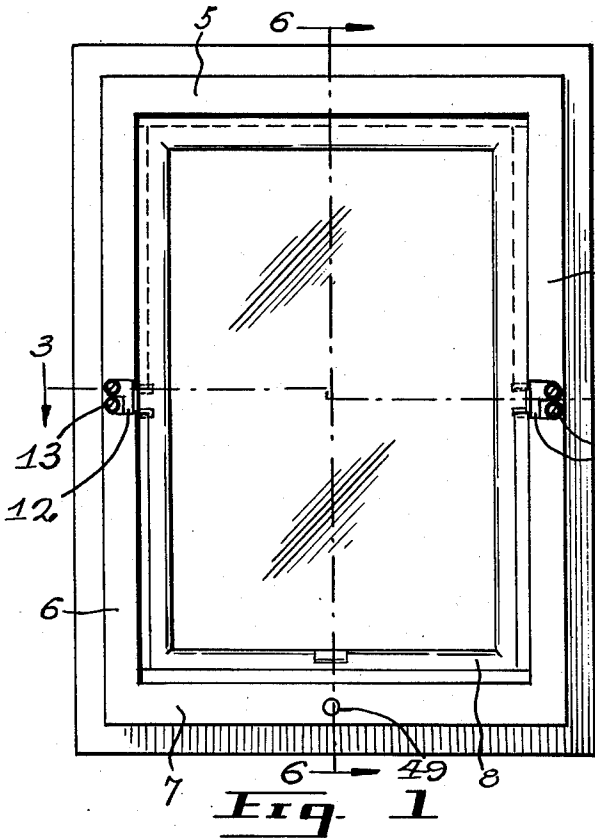

Inventor
Angel MORENO

By *Hetherington & Co.*
Attorneys

Oct. 10, 1961

A. MORENO

3,003,201

ROTARY TYPE WINDOWS

Filed April 14, 1960

2 Sheets-Sheet 2

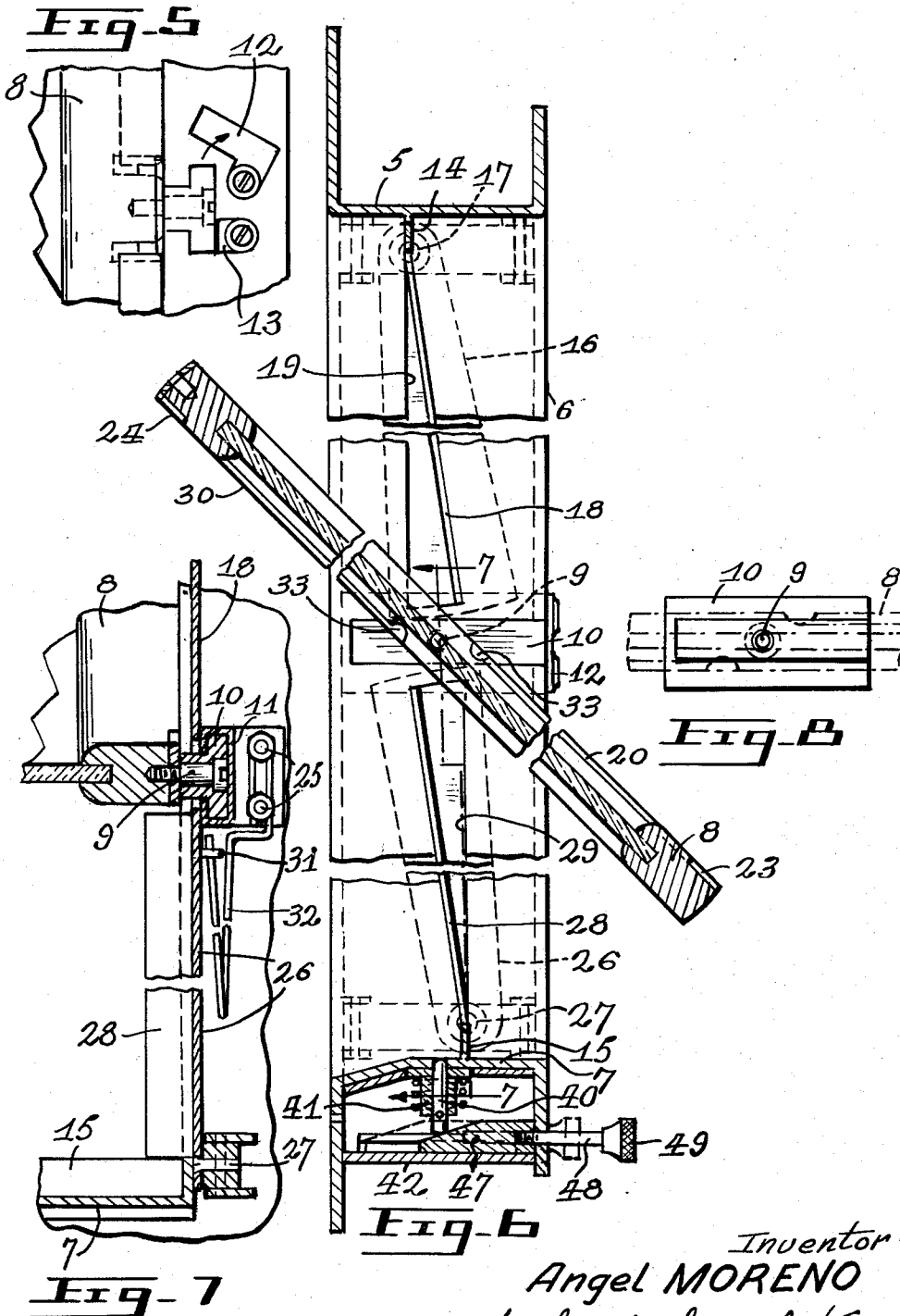

Inventor
Angel MORENO
By Hetherington & Co.
Attorneys

1

3,003,201

ROTARY TYPE WINDOWS

Angel Moreno, 5991 Victoria Ave., Montreal,
Quebec, Canada

Filed Apr. 14, 1960, Ser. No. 22,296

12 Claims. (Cl. 20—53)

This invention relates to improvements in rotary type windows which permit reversal of the sash to facilitate cleaning of the inner and outer surfaces of the glazing.

In countries having cold climates it is necessary to provide properly insulated window structures capable of being sealed or in close fit relation to prevent cold air from penetrating into a house or other building as well as to retain the heat manufactured within the building. One method is to provide double windows and in more modern constructions, aluminum-framed windows and like window sashes have been preferred as a closure means for providing contact or closure with the frames, for the reason that they will not expand and shrink under varying temperature conditions in the manner of wooden sashes.

Nevertheless, until now aluminum type frames and sashes have had the same disadvantage as the wooden ones, with regard to cleaning the outer surfaces thereof. Certain conventional windows are provided with fixed frames and sliding sashes which require cleaning of the exterior face of the glazing from outside. Others provide means for removing the sliding sashes so that they may be taken interiorly for cleaning. While the latter type has an advantage for sashes of comparatively light weight, it is not practical for large and heavy sashes of the type used in commercial establishments since their weight and size makes them too awkward to be manoeuvred.

Another disadvantage of the latter type of sash is that no means can be provided for excluding cold outside temperatures during the cleaning operation.

The present invention proposes to overcome all of the above disadvantages. One object of this invention is to provide a window comprising a fixed main frame structure and a sash structure which is pivoted about a central axis to the opposite sides of the frame whereby the sash may be rotated to present its outer face to the interior of a building in which the frame is mounted to facilitate cleaning of the outer surface of said sash.

Another object is to provide a frame structure of the character described with pivotally mounted shoulder flanges engageable with opposite surfaces of the sash at either side of the rotary axis of said sash and biasing means engaging said flanges so that, during rotation of the sash to its normal closed position, the frame will be compressed along its edges in contact with said flanges against the pressure of said biasing means, and during rotation of the frame in the opposite direction said biasing of the flanges will exert an impelling pressure on the frame to facilitate rotation of the frame.

Proceeding now to a more detailed description, reference will be had to the accompanying drawings, in which:

FIG. 1 is a front view of a window embodying my invention.

FIG. 2 is a side view with the sash in closed position.

FIG. 3 is a fragmentary section taken along line 3—3 of FIG. 1.

FIG. 4 is a fragmentary section taken along line 4—4 of FIG. 2.

FIG. 5 is a fragmentary detail view on the same plane as FIG. 1.

FIG. 6 is a section taken along line 6—6 of FIG. 1, with the sash partly open.

2

FIG. 7 is a fragmentary section taken along line 7—7 of FIG. 6.

FIG. 8 is an elevation in detail of a bearing block on which the window is rotatably mounted.

Referring more particularly to the drawings, numerals 5, 6 and 7 designate top, side and bottom metal frame members in which a sash 8 is pivotally mounted for rotation about a central horizontal axis by means of pins 9 which are carried by bearing blocks 10 slidably mounted on the outside of side frame members 6 in slideways 11 (FIG. 7). The bearing blocks 10 are T-shaped in cross-section, with the web protruding through an opening in said side frame member 6. Stops 12 (FIG. 5) pivotally mounted on the frame and abutted in closed position (FIG. 1) by abutments 13, lock the blocks 10 on the frame.

A sash stop shoulder formed as a flange 14 projects downwardly from the top frame 5 and is offset outwardly of the vertical center plane of the window frame (FIGS. 2 and 6) and a second flange 15 projects upwardly from the bottom frame member or sill 7 and is offset inwardly of the vertical center plane of the window frame; the amount of offset is such that when the sash is in its closed position it will be sealed at the top and bottom by said flanges 14 and 15, engaging recesses 23 and 24 respectively at the inner top and outer bottom of the sash.

A plate 16 is mounted on the outside of each side frame member 6 adjacent the upper end, to pivot about a horizontal axis pin 17 mounted on said frame member with its axis adjacent the lower tip of the flange 14. Plate 16 carries a shoulder flange 18 which projects through a sector-shaped slot 19 into the path of the upper half of the sash and is receivable in a recess 20 along the margin of the sash to provide a seal when the window sash is swung to its closed position. The plate 16 has a projecting pin 21 engaged by a bent wire spring 22 anchored on the side frame 6 which normally biases said plate member 16 to swing inwardly about its pivotal axis. Spring 22 is formed with a bent hook 24 embracing the pin 21, and at its other end it is looped over and fastened by bolts 25 (FIGS. 3 and 7) which also serve to secure the slideways 11 to the frame.

Additionally a second plate 26 is mounted on the outside of side frame 6 adjacent the lower end to pivot about a horizontal axis pin 27 mounted on said frame with its axis adjacent the upper edge of the flange 15 mounted on the sill. Plate 26 carries a shoulder flange 28 which projects through a sector-shaped slot 29 into the path of the lower half of the sash and is receivable in a recess 30 along the inner margin of the sash to provide a seal when the window sash is swung to closed position. Plate 26 also has a projecting pin 31 engaged by a bent wire spring 32 anchored in the side frame 6 to bias the plate 26 to swing outwardly about its pivotal axis. Spring 32 is mounted in a manner similar to spring 22.

The flanges 18 and 28 extend from the pivotal axes of pins 17 and 27 respectively, to points short of the central axis of pins 9 by a distance which is slightly greater than the thickness of the sash, so that when the sash is in a horizontal position it may be removed from the frame by sliding out the bearing blocks 10.

The recesses 20 and 30 on either side of the sash have rounded out depressions 33 at their inner ends which serve to receive initially the central ends of the flanges 18 and 28 when the sash is being rotated towards its normally closed position. As rotation proceeds during the closing of the window, the biasing of the flanges 18 and 28 through springs 22 and 32 respectively, causes the sash to resist closure. Thus when the window is fully

closed the flanges provide an effective seal along the sides of the window.

When the window is being swung to its reversed position for cleaning the said biasing on the flanges facilitates the rotation until contact of the flanges is broken at the depression 33 at the inner end of the recesses 20 and 30.

Each of the sector-shaped slots 19 and 29 has one radial edge vertical and aligned with the corresponding flange 14 or 15 and another radial edge inclined respectively outwardly and inwardly of the window frame. The vertical radial edges are designed to limit the pivotal movement of the plates 16 and 26 by abutting the flanges 18 and 28 as the window is rotated to its normally closed position. The inclined radial edges serve to limit the pivotal movement of the plates 16 and 26 in the opposite direction, by abutting the flanges 18 and 28 when the latter are in parallel planes spaced by a distance corresponding to the thickness of the sash 8. Thus when the sash is in its reversed position it abuts the flanges 18 and 28 to form therewith a seal which is by no means as perfect as the seal in the normal closed position, but which is useful to prevent excessive heat loss while the outer face of the sash glazing is being cleaned.

The plates 16 and 26 are of a size sufficient to cover slots 19 and 29 in all the pivoted positions of the plates, and at the center the plates 16 and 26 overlap the central ends of the flanges 18 and 28 and the circumferential edges of the slots.

Means are also provided to lock the window in its closed position. As shown in FIGS. 4 and 6 a latch pin 40 is slidably mounted in a bearing 41 secured against the lower face of the sill 7 by engagement with a casing 42 which contains the locking mechanism. The latch pin 40 is adapted to project through a bore in the sill 7, into a latch hole 43 to the bottom edge of sash 8. A coil spring 44 bearing against a cross pin 45 passing through the pin 40 and riding in a slot 46 of the bearing 41 urges the latch pin 40 into a retracted position. The lower end of the latch pin rides on a wedge block 47 slidably mounted on the bottom of the casing 42 and controlled through a connecting rod 48 by a knob 49. The wedge block 47 engages the pin 40 and raises it to operative position.

What I claim is:

1. A window comprising a frame having an inward and an outward face, a sash mounted on two opposite sides of said frame for rotation about a central axis, shoulders on the other two opposite sides of said frame offset respectively inwardly and outwardly of a plane of said frame containing said central axis by a distance corresponding substantially to half the thickness of said sash at its margins abutting said shoulders, shoulders on the first mentioned two opposite sides of said frame pivotally mounted about axes adjacent the outer edges of said first mentioned shoulders and extending short of said central axis by distances totalling at least the thickness of said sash at the central axis.

2. A window according to claim 1, further comprising first means to limit the pivotal movement of said pivotable shoulders in planes parallel to said plane of said frame in directions respectively inward and outward as the fixed shoulders corresponding to said pivotable shoulders are disposed inwardly and outwardly of said plane.

3. A window according to claim 2, further comprising second means to limit the pivotal movement of said pivotable shoulders in a direction opposite the direction limited by said first mentioned limiting means to a position wherein said pivotable shoulders lie in parallel

planes spaced by a distance corresponding to the thickness of said sash at its margins abutting said shoulders.

4. A window according to claim 3, further comprising biasing means urging said pivotable shoulders towards said second limiting means.

5. A window comprising a frame having an inward and an outward face, a sash mounted on two opposite sides of said frame for rotation about a central axis, shoulders on the other two opposite sides of said frame offset respectively inwardly and outwardly of a plane of said frame containing said central axis by a distance corresponding substantially to half the thickness of said sash at its margins abutting said shoulders, plates on the outside of the first mentioned two opposite sides of said frame pivotally mounted about axes adjacent the outer edges of said shoulders, generally sector-shaped slots having their centers at said pivotal axes of said plates, shoulder flanges mounted on said plates and projecting through said slots and extending from said pivotal axes of said plates to points short of said central axis by distances totalling slightly more than the thickness of said sash at the central axis.

6. A window according to claim 5, wherein said slots are dimensioned to limit the pivotal movement of said plates by abutting said shoulder flanges on one side in planes parallel to said plane of said frame in directions respectively inward and outward as the fixed shoulders corresponding to said shoulder flanges are disposed inwardly and outwardly of said plane, and on the other side to positions wherein said flanges lie in parallel planes spaced by a distance corresponding to the thickness of said sash at its margins abutting said shoulder flanges.

7. A window according to claim 6, further comprising springs urging said plates towards said other side.

8. A window according to claim 5, comprising bearing blocks mounted on said first mentioned two opposite sides of said frame removably slidable in a plane transverse to said plane of said frame containing said central axis, said sash being rotatably mounted on said blocks, and means to lock said blocks in a position wherein said central axis of rotation of said sash lies in said plane of said frame.

9. A window according to claim 5, wherein said sash has marginal recesses in which fit said shoulders and said shoulder flanges.

10. A window according to claim 9, further comprising rounded depressions of increased depth at the central ends of said marginal recesses receiving said shoulder flanges.

11. A window according to claim 5, further comprising a latch pin mounted on said frame, a latch hole on an edge of said sash adapted to receive said latch pin, and means to push out and retract said latch pin.

12. A window according to claim 5, further comprising a latch pin mounted on said frame, a spring urging said pin into retracted position, a latch hole on an edge of said sash adapted to receive said latch pin, and a slidable wedge block engageable with said latch pin to push out said latch pin.

References Cited in the file of this patent

UNITED STATES PATENTS

1,028,864	Driver	June 11, 1912
2,902,729	Gillespie	Sept. 8, 1959

FOREIGN PATENTS

974,517	France	Sept. 27, 1950
---------	--------	----------------