

(19) World Intellectual Property Organization
International Bureau



(43) International Publication Date
14 December 2006 (14.12.2006)

PCT

(10) International Publication Number
WO 2006/133464 A2

- (51) International Patent Classification:
E21D 21/00 (2006.01) E21D 20/02 (2006.01)
- (21) International Application Number:
PCT/ZA2006/000075
- (22) International Filing Date: 9 June 2006 (09.06.2006)
- (25) Filing Language: English
- (26) Publication Language: English
- (30) Priority Data:
2005/04781 9 June 2005 (09.06.2005) ZA
- (71) Applicant (for all designated States except US): **GRI-NAKER-LTA LIMITED [ZA/ZA]**; Of 12 Jurie Street, Alrode, 1449 Alberton (ZA).
- (72) Inventors; and
- (75) Inventors/Applicants (for US only): **DAWE, Steven, George [ZA/ZA]**; C/O 12 Jurie Street, Alrode, 1449 Alberton (ZA). **SPÄTH, Harald, Helmut, Otmar, Michael [ZA/ZA]**; C/O 12 Jurie Street, Alrode, 1449 Alberton (ZA). **PORTER, Neil, John [ZA/ZA]**; C/O 12 Jurie Street, Alrode, 1449 Alberton (ZA).
- (74) Agent: **McCALLUM, RADEMEYER & FREIMOND**; PO Box 1130, Maclyn House, 7 June Avenue, 2125 Bordeaux, (ZA).
- (81) Designated States (unless otherwise indicated, for every kind of national protection available): AE, AG, AL, AM, AT, AU, AZ, BA, BB, BG, BR, BW, BY, BZ, CA, CH, CN, CO, CR, CU, CZ, DE, DK, DM, DZ, EC, EE, EG, ES, FI, GB, GD, GE, GH, GM, HR, HU, ID, IL, IN, IS, JP, KE, KG, KM, KN, KP, KR, KZ, LC, LK, LR, LS, LT, LU, LV, LY, MA, MD, MG, MK, MN, MW, MX, MZ, NA, NG, NI, NO, NZ, OM, PG, PH, PL, PT, RO, RU, SC, SD, SE, SG, SK, SL, SM, SY, TJ, TM, TN, TR, TT, TZ, UA, UG, US, UZ, VC, VN, YU, ZA, ZM, ZW.
- (84) Designated States (unless otherwise indicated, for every kind of regional protection available): ARIPO (BW, GH, GM, KE, LS, MW, MZ, NA, SD, SL, SZ, TZ, UG, ZM, ZW), Eurasian (AM, AZ, BY, KG, KZ, MD, RU, TJ, TM), European (AT, BE, BG, CH, CY, CZ, DE, DK, EE, ES, FI, FR, GB, GR, HU, IE, IS, IT, LT, LU, LV, MC, NL, PL, PT,

[Continued on next page]

(54) Title: ROCK BOLT AND ROCK BOLT SHANK

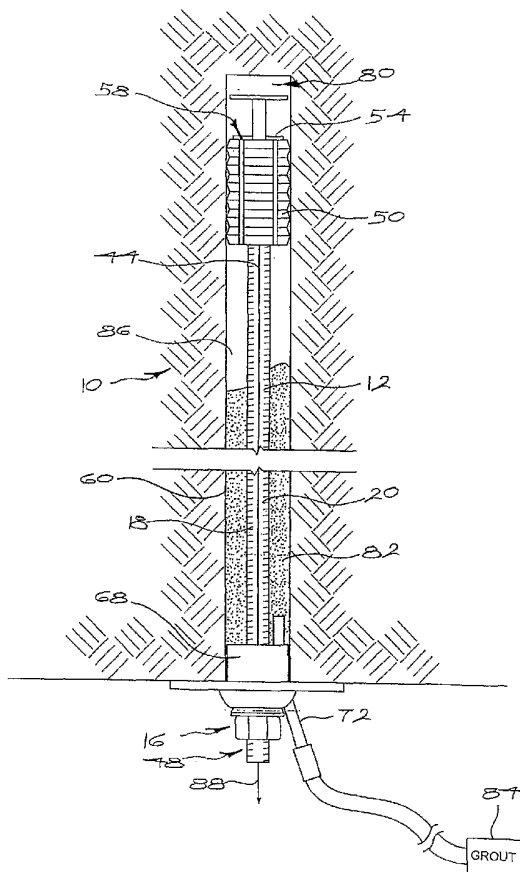

(57) Abstract: A rock bolt which includes an elongate threaded shank with at least one passage which extends longitudinally through the shank, a plurality of air leakage paths which extend between an outer surface of the shank and the passage, and an expansible mechanical anchor which is engaged with one end of the shank.

WO 2006/133464 A2



RO, SE, SI, SK, TR), OAPI (BF, BJ, CF, CG, CI, CM, GA, GN, GQ, GW, ML, MR, NE, SN, TD, TG).

For two-letter codes and other abbreviations, refer to the "Guidance Notes on Codes and Abbreviations" appearing at the beginning of each regular issue of the PCT Gazette.

Published:

— *without international search report and to be republished upon receipt of that report*

ROCK BOLT AND ROCK BOLT SHANKBACKGROUND OF THE INVENTION

[0001] This invention relates to a rock bolt of the kind used for example in an underground situation for the reinforcement of a rock face.

5 [0002] A rock bolt can be mechanically anchored in position, in a hole in a rock face, to provide immediate support or reinforcement. The mechanical anchor generally results in a "point anchor" system wherein a substantial load is imparted to a surrounding body of rock in a relatively small region.

10 [0003] A rock bolt can also be fixed in position using a settable material such as a resin or grout, collectively referred to herein as "grout". When grout is employed a shank of a rock bolt can be adhered to a wall of a hole in which the rock bolt is located, over substantially its entire length. This is advantageous.

15 [0004] Both approaches can be used in order to achieve an immediate load-bearing capability from the mechanical anchor and a distributed load-bearing characteristic which arises once the grout has set.

20 [0005] It is necessary to inject the grout into an annular space between opposing surfaces of the rock bolt shank and the wall of the hole. As the grout is fluent a seal should be employed to prevent the grout from flowing out of a hole into which it is introduced. The seal however also traps air in the annular space and it is therefore necessary to provide a mechanism which allows air to escape, when grout is placed into the annular space, to ensure that the annular space is, as far is practicable, filled completely with grout.

[0006] The invention is concerned with a rock bolt and a rock bolt shank which, at least partly, permit this problem to be addressed.

SUMMARY OF INVENTION

5 [0007] The invention provides, in the first instance, a component for use in a shank of a rock bolt which includes an elongate body, a partial thread formation on a surface of the body and at least one elongate channel which extends longitudinally in the body surface and which is flanked by longitudinally extending sections of the body surface.

10 [0008] In cross section the body may have a substantially convex portion which carries the partial thread formation and a relatively flat portion in which the at least one elongate channel is formed.

[0009] The longitudinally extending sections may be substantially flat with a single elongate channel positioned between them, centrally or off-centre.

15 [0010] The flat longitudinally extending sections may include grooves or shallow recessed formations which extend to the channel, generally in a transverse direction to the longitudinal direction of the channel.

20 [0011] The invention extends, in the second instance, to a rock bolt shank which includes at least two of the aforementioned components positioned side by side and parallel to each other with the respective longitudinally extending sections in contact with one another and with the respective partial thread formations aligned to form a substantially continuous thread with which a nut is threadedly engageable.

[0012] The nut may be threadedly engaged with a first end of the shank and an expansible anchor of any appropriate kind may be engaged with an opposing second end of the shank.

5 **[0013]** A seal may be provided at the first end and a passage for grout flow may extend past the seal. The passage may be formed by a conduit or pipe which extends through the seal.

10 **[0014]** The invention also extends to a rock bolt which includes a shank which is formed from at least two elongate parallel side by side components which, on an outer side, define a thread formation and which have contacting opposed inner surfaces which define between them at least one longitudinally extending passage and a nut which is engaged with the thread at a first end of the shank.

[0015] An expansible mechanical anchor may be engaged with the shank at a second end which is remote from the first end.

15 **[0016]** The contacting opposed inner surfaces may inherently form a plurality of air leakage paths between an outer surface of the shank, and the passage. Alternatively or additionally these paths may be provided by forming grooves or recesses in the inner surfaces, between what in use is the outer surface of the shank, and the passage.

20 **[0017]** Thus, according to a different aspect of the invention, there is provided a rock bolt which includes an elongate threaded shank with at least one passage which extends longitudinally through the shank, a plurality of air leakage paths which extend between an outer surface of the shank and the passage, and an expansible mechanical anchor which is engaged with one end of the shank.

5 [0018] The invention also provides a method of making a rock bolt which includes the steps of forming an elongate section with a substantially convex surface portion which carries a partial thread formation and a relatively flat portion in which is located at least one longitudinally extending channel, parting the section into at least a first component and a second component, positioning the components side by side and parallel to each other with the respective flat portions opposing and contacting each other so that a substantially continuous thread is formed by the respective thread formations, and engaging a nut with the thread at first ends of the components.

10 [0019] An expansible mechanical anchor may be engaged with the components at second ends which are remote from the first ends.

15 [0020] According to another aspect of the invention there is provided a method of installing a rock bolt which includes the steps of locating an elongate shank in a hole in a rock body, expanding a mechanical anchor on the shank into engagement with a wall of the hole, sealing an interface between the shank and the rock body at least at a mouth of the hole, injecting a settable material into the hole around the shank, allowing air in the hole to escape through at least one air flow path in a side of the shank into a passage inside the shank, and from the passage to atmosphere, and allowing the settable material to set in binding contact with the shank and the wall of the hole.

20 BRIEF DESCRIPTION OF THE DRAWINGS

[0021] The invention is further described by way of examples with reference to the accompanying drawings in which:

Figure 1 is an exploded view in perspective of part of a rock bolt according to the invention;

Figure 2 shows two components of the rock bolt, in perspective and displaced from each other;

5 Figure 3 is a side view of a shank of the rock bolt;

Figure 4 is a view in cross section of the shank in Figure 3 on a slightly enlarged scale;

Figure 5 is a perspective view of the rock bolt, fully assembled, placed in a hole in a body of rock;

10 Figure 6 is a side view, in section, showing the rock bolt in the process of being installed; and

Figures 7 and 8 are views which correspond respectively to Figures 3 and 4 and which illustrate variations of the invention.

DESCRIPTION OF PREFERRED EMBODIMENTS

15 **[0022]** Figure 1 of the accompanying drawings illustrates in perspective and in exploded form part of a rock bolt 10 according to the invention.

[0023] The rock bolt includes a shank 12, a mechanical anchor 14 and a nut 16.

20 **[0024]** The shank 12 is formed from two components designed 18 and 20. Figure 2 shows the components 18 and 20 in perspective and slightly displaced from each other, Figure 3 shows the shank from one side while Figure 4 is a cross sectional view of the shank on a slightly enlarged scale.

[0025] The components are identical and are cut, to an appropriate length, according to requirement from an elongate section formed by an appropriate cold

rolling process. In the cold rolling process the section is formed with a partial thread formation 22 over an outer curved or convex surface 24, see Figure 4. To simplify continuous manufacture of the elongate section the thread formation extends over the full length of the section. This however is not essential for the thread can be formed only over these portions of the section which are ultimately to be engaged with a nut or nuts. An opposing surface 26, which nominally is flat, has a centrally positioned channel 30 which extends longitudinally and which is flanked by two relatively flat substantially identical sections 32 and 34 respectively.

[0026] The components 18 and 20 are positioned side by side and parallel to each other with the flat sections 32 and 34 of the respective components in contact with each other. In this way a substantially continuous thread formation 36 is formed on an outer surface of the shank and a central longitudinal extending passage 38, defined by the opposed and mating channels 30 in the two components, is formed in the centre of the shank.

[0027] The thread 36 is interrupted by two relatively smooth surfaces 40 and 42 respectively formed over and adjacent junctions 44 and 46 of the respective mating flat sections 32 and 34. Nonetheless the arrangement is such that the nut 16 of appropriate dimensions, can be threadedly engaged with the thread formation 36 at a first end 48 of the shank. When this occurs the components 18 and 20 are kept together and relative movement of the components is for all practical purposes eliminated while the nut 16 can be threadedly moved along the shank, as required, in either direction.

[0028] The mechanical anchor 14 can be of any appropriate construction. In the illustrated embodiment the anchor includes three substantially identical shells 50

which are attached to a bail 52. A threaded conical member 54 is positioned inside the bail amongst tapered ends of the shells. The thread 36 at a second end 56 of the shank which is inserted into a passage 58 formed by the shells is engageable with the member 54. This aspect, as noted, is substantially conventional.

5 **[0029]** Figure 5 illustrates in perspective an assembled rock bolt placed in a hole 60 which is formed from a rock face 62 into a body of rock 64, in an underground situation.

10 **[0030]** The rock bolt is assembled in the manner which has been described but, prior to engagement of the nut with the shank, a load distributing washer 66 is passed onto the shank from its first end 48. A flexible seal 68 is also passed onto the shank and rests on an inner side 70 of the washer 66. A flexible filler pipe 72 passes through a passage in the seal and through a hole 74 in the washer.

15 **[0031]** Figure 6 illustrates the rock bolt 10 during a process of installation. When the nut 16 is threadedly advanced along the shank the conical member 54 is drawn into the passage 58 and the shells are forced radially apart. The mechanical anchor is thereby expanded into frictional contact with a wall 80 of the hole and the rock bolt is firmly mechanically anchored in position providing immediate support for the rock face.

20 **[0032]** Grout 82 from a suitable source 84 is then pumped via the pipe 72 into an annular space 86 formed between opposing surfaces of the wall 80 and the shank 12. Depending at least on the orientation of the hole 60 the annular space is filled in a particular manner e.g. from one end towards the other, at a central region or the like. In order for the annular space to be completely filled with grout it is necessary

for the air in the annular space to be able to escape to atmosphere. As the grout pressurises the annular space air is expelled through small gaps which exist, inherently, at the junctions 44 and 46 i.e. at the interfaces between the components 18 and 20. On the other hand these gaps are sufficiently small to prevent any meaningful escape of grout from the hole. Air flows into the central passage 38 and, as is indicated by an arrow 88 in Figure 6, can escape from the mouth of the channel at the first end 48 of the shank.

[0033] The seal 68 fits neatly into the hole 60 and seals the interface between the shank and the surrounding wall 80 at the mouth of the hole. This means that the grout can more readily fill the annular space and consequently the effectiveness of the bond between the shank and the body of rock is enhanced.

[0034] The air can enter the passage 38 anywhere along its length. Air pockets or bubbles which could become trapped in the grout this have the capability to escape to atmosphere anywhere along the length of the rock bolt. This benefit is not possible, for example, if reliance is placed only on air being able to escape from the hole through the mouth of the passage 38 at the second end 56 of the shank.

[0035] Figures 7 and 8 are views which correspond substantially to Figures 3 and 4 respectively and illustrate modifications which can be made to the rock bolt.

[0036] Figure 7 shows a modified shank 12A formed from two sections 18A and 20A respectively which generally are similar to the components 18 and 20. However the surfaces of the sections 32 and 34 which, otherwise are flat, are formed during the cold rolling process with small transversely extending grooves or depressions 90. Once the components are assembled to form the shank these formations provide a

plurality of definite air flow paths to the central passage. The cross sectional dimensions of these flow paths should however not be so large that they allow for the escape of any meaningful quantity of grout from the hole 60 into the passage.

5 **[0037]** Figure 8 illustrates a construction wherein the channel 30 is not centrally positioned, as is shown in Figure 4 but instead, the channel, designed 30A, is offset. The resulting components 18B and 20B are, as before, identical but when they are engaged with each other from two relatively small passages 38A and 38B as opposed to the single passage 38 shown in Figure 4.

CLAIMS

1. A component for use in a shank of a rock bolt which includes an elongate body, a partial thread formation on a surface of the body and at least one elongate channel which extends longitudinally in the body surface and which is flanked by longitudinally extending sections of the body surface.
2. A component according to claim 1 wherein the body has a substantially convex portion which carries the partial thread formation and a relatively flat portion in which the at least one elongate channel is formed.
3. A component according to claim 1 or 2 wherein the longitudinally extending sections are substantially flat with a single elongate channel positioned between them, centrally or off-centre.
4. A component according to any one of claims 1 to 3 which is formed with grooves or shallow recessed formations, in the longitudinally extending sections, which extend to the channel, in a transverse direction to the longitudinal direction of the channel.
5. A rock bolt shank which includes at least two components, each component being according to any one of claims 1 to 4, wherein the components are positioned side by side and parallel to each other with the respective longitudinally extending sections in contact with one another and with the respective partial thread formations aligned to form a substantially continuous thread with which a nut is threadedly engageable.

6. A rock bolt shank according to claim 5 wherein a nut is threadedly engaged with a first end of the shank and an expansible anchor is engaged with an opposing second end of the shank.
7. A rock bolt shank according to claim 6 which includes a seal at the first end and a passage for grout flow which extends past the seal.
8. A rock bolt which includes a shank which is formed from at least two elongate parallel side by side components which, on an outer side, define a thread formation and which have contacting opposed inner surfaces which define between them at least one longitudinally extending passage and a nut which is engaged with the thread at a first end of the shank.
9. A rock bolt according to claim 8 which includes an expansible mechanical anchor which is engaged with the shank at a second end which is remote from the first end.
10. A rock bolt which includes an elongate threaded shank with at least one passage which extends longitudinally through the shank, a plurality of air leakage paths which extend between an outer surface of the shank and the passage, and an expansible mechanical anchor which is engaged with one end of the shank.
11. A method of making a rock bolt which includes the steps of forming an elongate section with a substantially convex surface portion which carries a partial thread formation and a relatively flat portion in which is located at least one longitudinally extending channel, parting the section into at least a first component and a second component, positioning the components side by side

and parallel to each other with the respective flat portions opposing and contacting each other so that a substantially continuous thread is formed by the respective thread formations, and engaging a nut with the thread at first ends of the components and engaging an expansible mechanical anchor with the components at second ends which are remote from the first ends.

5

12. A method of installing a rock bolt which includes the steps of locating an elongate shank in a hole in a rock body, expanding a mechanical anchor on the shank into engagement with a wall of the hole, sealing an interface between the shank and the rock body at least at a mouth of the hole, injecting a settable material into the hole around the shank, allowing air in the hole to escape through at least one air flow path in a side of the shank into a passage inside the shank, and from the passage to atmosphere, and allowing the settable material to set in binding contact with the shank and the wall of the hole.

10

