

(19) World Intellectual Property
Organization
International Bureau



(43) International Publication Date
8 December 2005 (08.12.2005)

PCT

(10) International Publication Number
WO 2005/115853 A1

- (51) International Patent Classification⁷: **B65D 19/42**
- (21) International Application Number:
PCT/EP2005/052380
- (22) International Filing Date: 24 May 2005 (24.05.2005)
- (25) Filing Language: English
- (26) Publication Language: English
- (30) Priority Data:
04425376.3 25 May 2004 (25.05.2004) EP
- (71) Applicant (for all designated States except US): **ITALFIL SNC DI GUERRA WALTER & C.** [IT/IT]; Via dell'Artigianato, 45, I-25039 Travagliato (IT).
- (72) Inventor; and
- (75) Inventor/Applicant (for US only): **GUERRA, Mauro Roberto** [IT/IT]; c/o Italfil Snc di Guerra Walter, & C., Via dell'Artigianato, 45, I-25039 Travagliato (IT).
- (74) Agents: **SINISCALCO, Fabio** et al.; Jacobacci & Partners S.p.A., Foreign Patents, Via delle Quattro Fontane, 15, I-00184 Rome (IT).
- (81) Designated States (unless otherwise indicated, for every kind of national protection available): AE, AG, AL, AM, AT, AU, AZ, BA, BB, BG, BR, BW, BY, BZ, CA, CH, CN, CO, CR, CU, CZ, DE, DK, DM, DZ, EC, EE, EG, ES, FI, GB, GD, GE, GH, GM, HR, HU, ID, IL, IN, IS, JP, KE, KG, KM, KP, KR, KZ, LC, LK, LR, LS, LT, LU, LV, MA, MD, MG, MK, MN, MW, MX, MZ, NA, NG, NI, NO, NZ, OM, PG, PH, PL, PT, RO, RU, SC, SD, SE, SG, SK, SL, SM, SY, TJ, TM, TN, TR, TT, TZ, UA, UG, US, UZ, VC, VN, YU, ZA, ZM, ZW.
- (84) Designated States (unless otherwise indicated, for every kind of regional protection available): ARIPO (BW, GH, GM, KE, LS, MW, MZ, NA, SD, SL, SZ, TZ, UG, ZM, ZW), Eurasian (AM, AZ, BY, KG, KZ, MD, RU, TJ, TM), European (AT, BE, BG, CH, CY, CZ, DE, DK, EE, ES, FI,

[Continued on next page]

(54) Title: TROLLEY BASE AND TROLLEY WITH THIS BASE

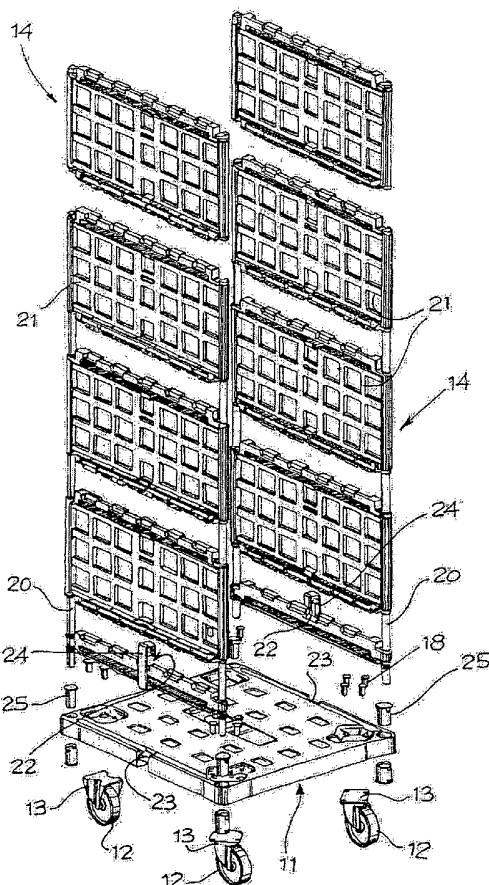

(57) Abstract: Described is a base for a trolley for storing and transporting merchandise, the trolley being substantially constituted by a hollow body (11) in plastic material obtained by means of an extrusion and blowing process. The resulting base has a structure that is both light and rigid and does not call for particular surface treatments. Also described is a trolley that utilizes this base.

WO 2005/115853 A1



FR, GB, GR, HU, IE, IS, IT, LT, LU, MC, NL, PL, PT, RO,
SE, SI, SK, TR), OAPI (BF, BJ, CF, CG, CI, CM, GA, GN,
GQ, GW, ML, MR, NE, SN, TD, TG).

— *before the expiration of the time limit for amending the
claims and to be republished in the event of receipt of
amendments*

Published:

— *with international search report*

*For two-letter codes and other abbreviations, refer to the "Guid-
ance Notes on Codes and Abbreviations" appearing at the begin-
ning of each regular issue of the PCT Gazette.*

- 1 -

TROLLEY BASE AND TROLLEY WITH THIS BASE**DESCRIPTION**

[0001] The present invention relates to trolleys for storing merchandise and, more particularly, to a
5 base for such trolleys.

[0002] Various types of trolleys are known for use in warehouses, supermarkets, airports, etc., substantially constituted by a base provided with wheels, with at least two side pieces that extend
10 perpendicularly from the base and possibly with planes parallel to the base fixed to the side pieces. Some known trolleys are wholly realized in electrically welded steel wire, others are wholly realized in wood or rigid plastic material and yet others are realized with
15 the use of said materials in different combinations, for example, the base may be of wood and the side pieces and the possible planes may be made of steel wire.

[0003] The known trolleys are associated with various drawbacks that are more or less grave according
20 to the specific use that is made of the trolleys. In particular, especially when they are intended to be used in the open, they call for accurate finishing treatments to avoid their surfaces becoming deteriorated due to the effect of the exposure to atmospheric agents. These
25 treatments are relatively demanding in terms of cost and

- 2 -

maintenance. In any case, the known trolleys are rather heavy on account of the characteristics of the employed materials and the quantity of materials necessary for assuring the robustness and rigidity of the structure.

5 **[0004]** The principal object of the present invention is to make available a base for a trolley and a trolley for the storage and transport of merchandise that will make it possible to avoid the drawbacks of the prior art, in particular trolleys that have a light
10 structure and are yet rigid and do not call for particular surface treatments.

[0005] This and other objects are attained by realizing the base and the trolley defined in general terms in, respectively, Claim 1 and Claim 13 and, in
15 particular embodiments, in the dependent claims.

[0006] The invention will be more readily understood from the following detailed description, which is given by way of example and is not to be considered limitative in any way, the description making
20 reference to the attached drawings, of which:

- Figure 1 shows the trolley in accordance with the invention as a perspective exploded view,

- Figures 2 and 3 show perspective views, respectively from above and below, of a base in

- 3 -

accordance with the invention with four wheels already mounted,

- Figure 4 is a plan view from above of the base in accordance with Figures 2 and 3,

5 - Figure 5 is a section view along the line V-V of the base shown in Figure 4,

- Figure 6 is a view of a detail of the base in accordance with Figures 2 to 5 with one wheel mounted, and

10 - Figure 7 is a section view along the line VII-VII of the detail of Figure 6 with the mounted wheel.

[0007] As can be seen in Figure 1, a trolley in accordance with the invention comprises a base 11 of a substantially quadrangular shape, four wheels 11 fixed to the base by means of respective stirrups 13 and two flanks 14 united with the base 11 along two opposite base sides.

[0008] The base 11 is substantially constituted by a flattened hollow body of plastic material, high-density polyethylene for example, formed by means of a hot extrusion and blowing process. The blowing is performed in a mould shaped in such a manner as to form two thin principal walls that face each other and have reliefs facing towards the interior of the hollow body, as is shown in particular in Figures 2 to 5. In this

- 4 -

example the reliefs are substantially of a boxlike shape with a flat end surface very close to the opposite wall. According to a variant, the mould may be configured in such a manner that the flat end surfaces arrive to touch
5 the opposite wall and to become welded to it when the plastic material is still in the thermoplastic state.

[0009] The reliefs, indicated by 15 in Figures 3 and 5, formed on the lower wall of the base, i.e. the face to which there will be fixed the stirrups with the
10 wheels, are regularly arranged in such a manner as to constitute uniformly distributed support points for a load placed on the base. In this way one obtains a base that, thanks to the numerous reliefs that jointly and severally constitute a supporting surface, is rigid and,
15 thanks to the small quantity of material utilized, is also light.

[0010] On the upper wall of the base in this example there are formed four reliefs, indicated by 16 in Figures 2 and 4 and likewise of boxlike shape, in
20 proximity of the four corners of the base. These reliefs extend as far as the opposite wall in the positions of the mounting surfaces for the stirrups 13 of the wheels. The stirrups 13 are fixed to the base 11 by means of four self-threading screws 17 that pass through the two
25 walls of the base and become engaged with corresponding

- 5 -

cylindrical elements 18 arranged on the opposite wall, as is shown particularly in Figures 6 and 7.

[0011] Further reliefs are formed on one or the other of the two walls, or on both, in proximity of the corners of the base in such a manner as to form pairs of adjacent cup-like structures having the bases in common. The bases are at least partially removed after the blowing, thereby obtaining four through holes 19. In a particularly preferred embodiment, the trough holes are directly formed in the mould and have substantially cylindrical internal walls that define respective channels extending between the upper wall and the lower wall of the base 11.

[0012] In the shown example the side pieces 14 of the trolley are constituted by four rod-shaped uprights 20 inserted in the through holes 19 of the base and by panels 21, once again preferably formed by means of extrusion and blowing, each of which has two through holes that extend parallel to two opposite sides and are crossed by the uprights, as is shown by Figure 1. A trolley with side pieces formed in this manner is described in detail in the international application PCT/IT03/00800 filed on 5 December 2003 and entitled "Trolley panel".

- 6 -

[0013] The panels 21 are united with each other by means of joints provided on their edges perpendicular to the uprights. The lowest panel on each side piece in this particular example has a limited vertical extension
5 and is shaped in such a manner as to provide a seating 22 that, together with a corresponding seating 23 provided on the base 11, serves to fix the side piece 14 to the base. For this purpose there are provided two elastic elements 24 that are shaped in such a manner as
10 to be capable of being inserted by means of a snap fit into the above-described seatings and thus keeping the two side pieces attached to the base.

[0014] As is shown in Figure 1, in a non-limitative embodiment, collars 25, made of nylon for example, are
15 fitted into the respective through holes 19 of the base 11. These collars serve to reduce the diameter of the holes in the cases in which, as in the illustrated example, the uprights have a section smaller than the section of the holes. This measure enhances the use
20 versatility of the base. In a different and particularly preferred embodiment, in which the trough holes 19 are directly formed in the mould and have substantially cylindrical internal walls that define respective channels extending between the upper wall and the lower
25 wall of the base 11, the uprights 20 are suitable to be

- 7 -

inserted in respective holes 19 without the use of collars 25. More preferably, in this case two of four channels have a substantially circular section while the other two channels advantageously have a substantially slot-shaped section. The slot-shaped section channels are each provided on a respective side of the base in such a way that of the two uprights 20 supporting the same panel 21 one of said upright 20 is received in a circular section channel while the other one 20 is received in a slot-shaped section channel.

[0015] According to embodiments of the invention to be used in case merchandise sensitive to temperature leaps has to be stored and transported, the hollow body of the base is filled with a heat insulation material or with a eutectic solution of the same type as is usually utilized in the so-called eutectic plates.

[0016] According to another embodiment that can be used with advantage in case urgent or valuable merchandise has to be stored and transported, in the hollow body of the base there may be accommodated a satellite transmission system to ascertain the position of the trolley.

In a particularly advantageous embodiment, four regions of the hollow body 11 substantially corresponding to the four corners of the base are filled

- 8 -

with a resin having the purpose of strengthening such corners. Preferably, such resin is injected in the base 11 after the blowing phase into respective cavities provided in the mould. More preferably such resin is a
5 bicomponent resin. In a particularly preferred embodiment, such resin is an unsaturated polyester resin having a percentage of styrene comprised in the range 15% - 35% and more preferably comprised in the range 20% - 30%.

10 [0017] What has been said above makes it clear that the objects of the invention are fully attained. In fact, the trolley base in accordance with the invention is a light and at the same time robust structure that can be realized in an economic manner with automatic
15 equipment and in a brief space of time. Furthermore, the hollow body of the base can be realized by utilizing plastic material, possibly capable of being recycled, that can readily be coloured with the desired shades and does not call for surface finishing and maintenance
20 treatments.

[0018] Lastly, even though only one embodiment of the invention has been shown and described in detail, it is clear that many variants are possible within the ambit of the same inventive concept. For example, the
25 reliefs formed on the walls of the base may also be very

- 9 -

different in shape and number from the ones shown in order to satisfy particular functional and/or structural requirements, the surfaces of the base intended for the mounting of the wheel stirrups could be more or less
5 than four and the means for fixing the side pieces to the base could be different from the ones shown and described. The trolley in accordance with the invention could likewise be different from the one described, always provided that it employs a base in accordance
10 with the invention: the two side pieces, for example, could be realized by means of hot-welded steel wire or some other material and could also be more than two.

- 10 -

CLAIMS

1. A base of a trolley for the storage and transport of merchandise, characterized in that it comprises a hollow body (11) in plastic material
5 obtained by means of an extrusion and blowing process.

2. A base in accordance with Claim 1, wherein the hollow body (11) comprises two walls that face each other with reliefs (15, 16) towards the inside of the body.

10 3. A base in accordance with Claim 2, in which said base is of substantially quadrangular shape having a mounting surface for a stirrup (13) as support for a wheel in proximity of each of its four corners.

4. A base in accordance with Claim 3, having four
15 through holes (19), each of said through hole (19) being located in proximity of a respective corner of the base.

5. A base according to claim 3, in which said four holes (14) have substantially cylindrical internal walls that define respective channels, two said channels
20 having a substantially circular section while the other two of said channels having a substantially slot-shaped section.

6. A base in accordance with Claim 4, comprising a collar (25) fitted into each of the through holes (19).

- 11 -

7. A base in accordance with any one of the preceding claims, wherein the hollow body (11) is filled with a heat insulation material.

8. A base in accordance with any one of Claims 1
5 to 5, wherein the hollow body (11) is filled with a eutectic solution.

9. A base according to any of the preceding claims, in which said base is of substantially quadrangular shape and in which four regions of the
10 hollow body (11) substantially corresponding to the four corners of the base are filled with a resin having the purpose of strengthening such corners.

10 A base according to claim 8, wherein said resin is an unsaturated polyester resin.

15 11. A base in accordance to claim 10, wherein said resin has a percentage of styrene comprised in the range 15% - 35%.

12. A base in accordance to claim 11, wherein said resin has a percentage of styrene comprised in the range
20 20% - 30%.

13. A trolley for the storage and the transport of merchandise comprising a base (11) in accordance with any one of the preceding claims.

14. A trolley for the storage and the transport of
25 merchandise comprising a base (11) in accordance with

- 12 -

any one of Claims 4 to 12, four rod-shaped uprights (20) inserted in the through holes (19) of the base and at least two side pieces (14) supported by the four uprights (20).

5 15. A trolley in accordance with Claim 14, wherein the side pieces (14) are formed by panels (21), each of which has two through holes that extend parallel to its two opposite sides for the passage of the respective uprights.

10 16. A trolley in accordance with Claim 14 or Claim 15, comprising coupling means (22, 23, 24) between the base and the side pieces (14).

 17. A trolley in accordance with Claim 16, wherein the coupling means comprise an elastic element (24)
15 associated with each side piece and shaped in such a manner as to become hooked onto the base (11) and the side piece (14) by means of a snap fit.

 18. A trolley in accordance with any one of Claims
14 to 17, wherein the panels (21) comprise a hollow body
20 in plastic material obtained by means of extrusion and blowing.

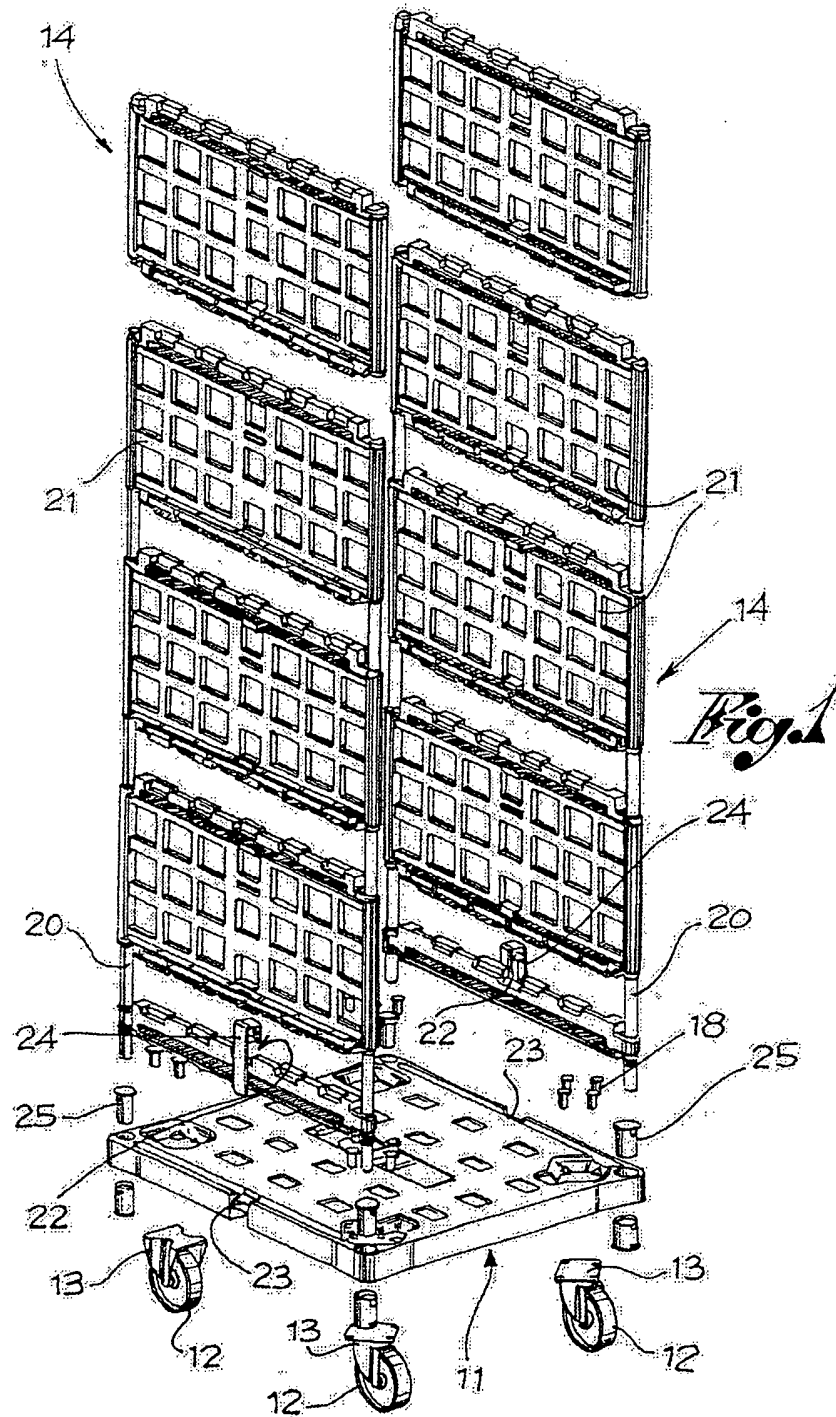

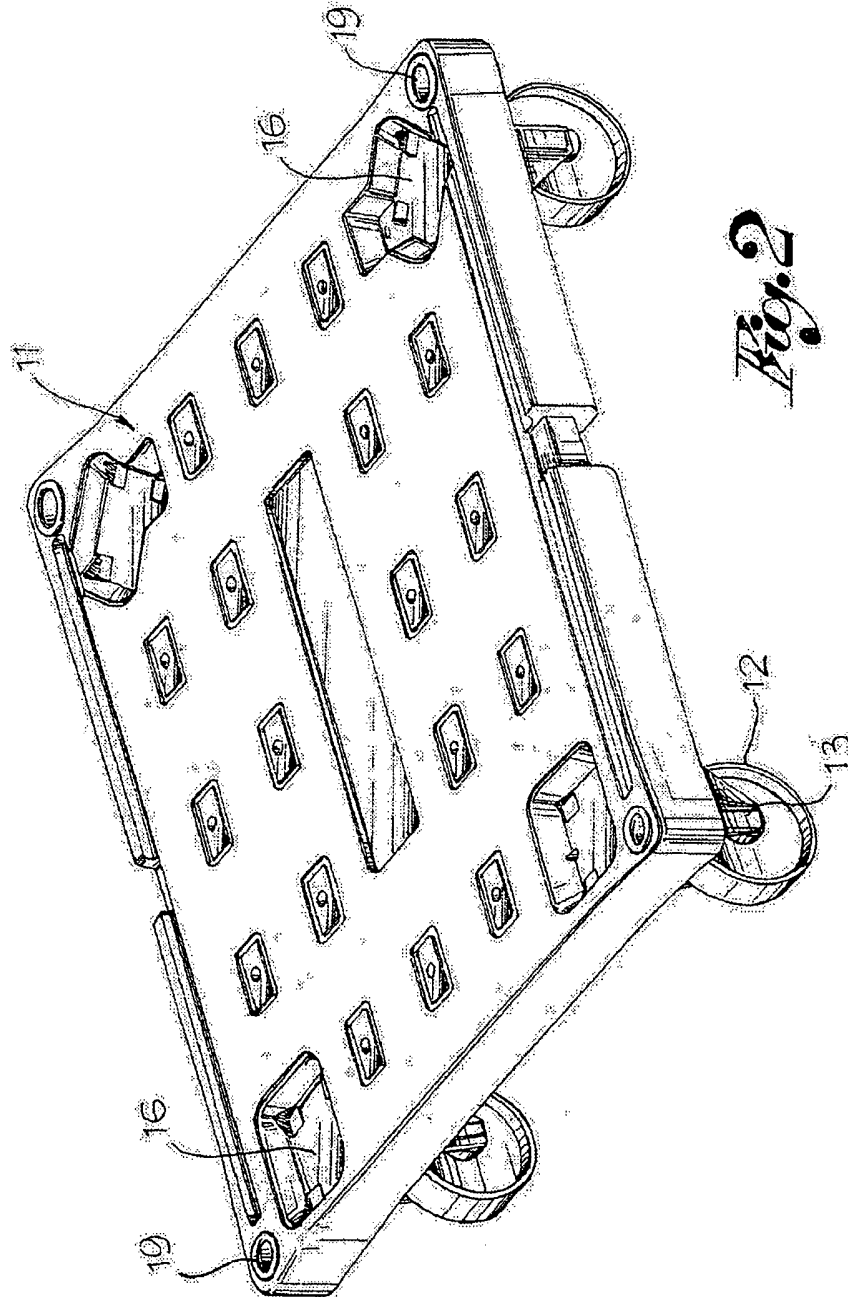

Fig. 2

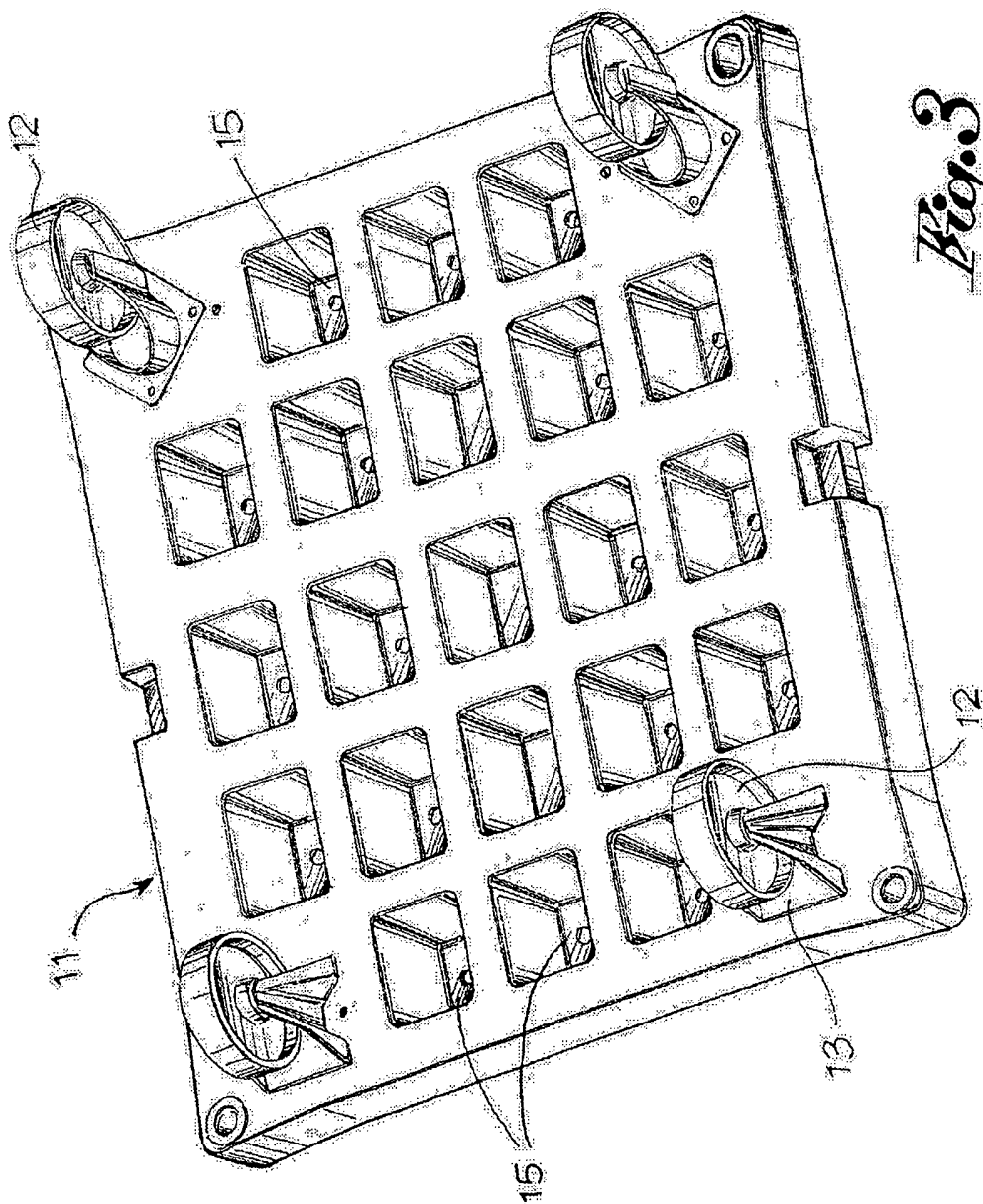

Fig. 3

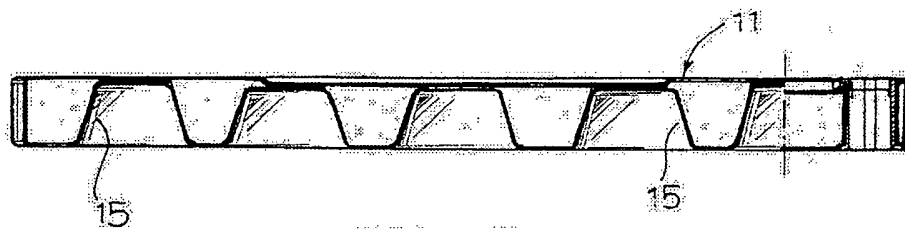

Fig. 5

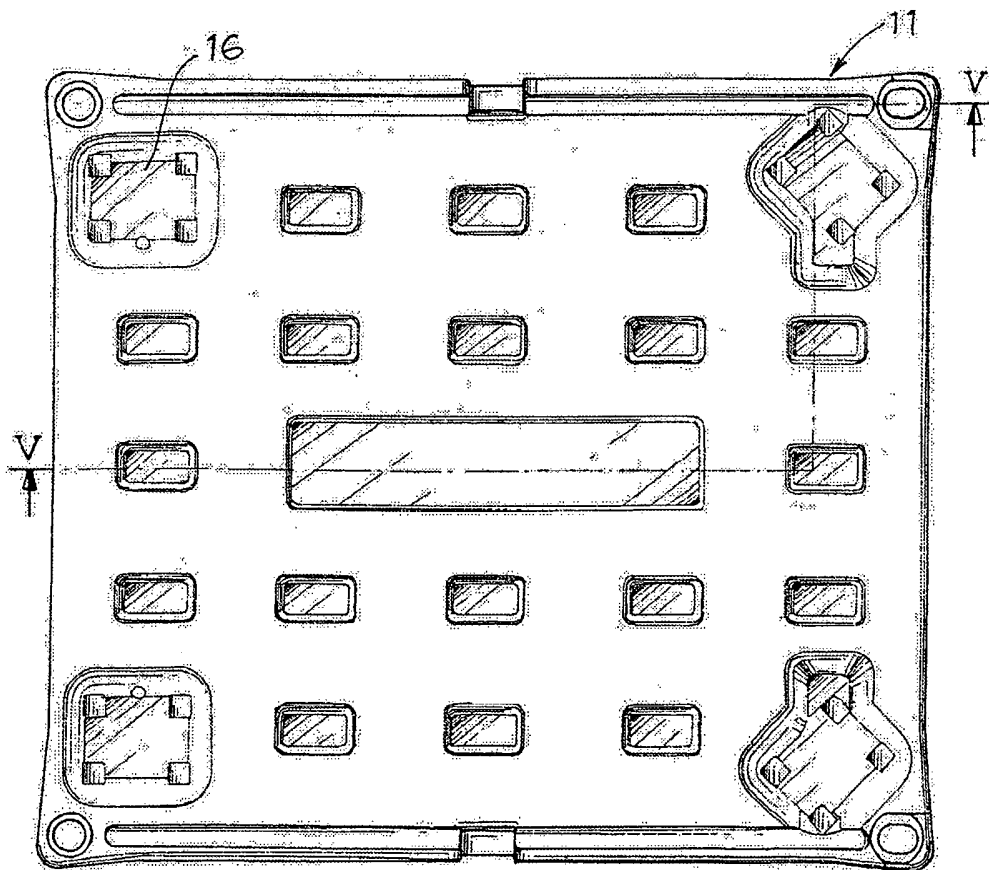

Fig. 4

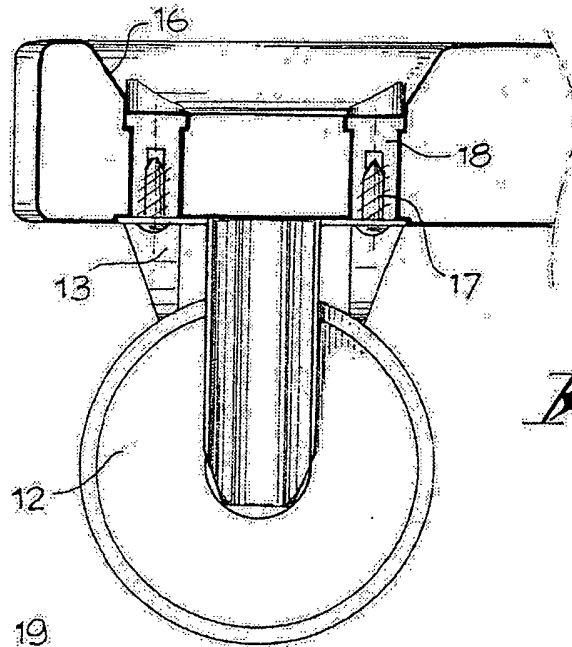

Fig. 7

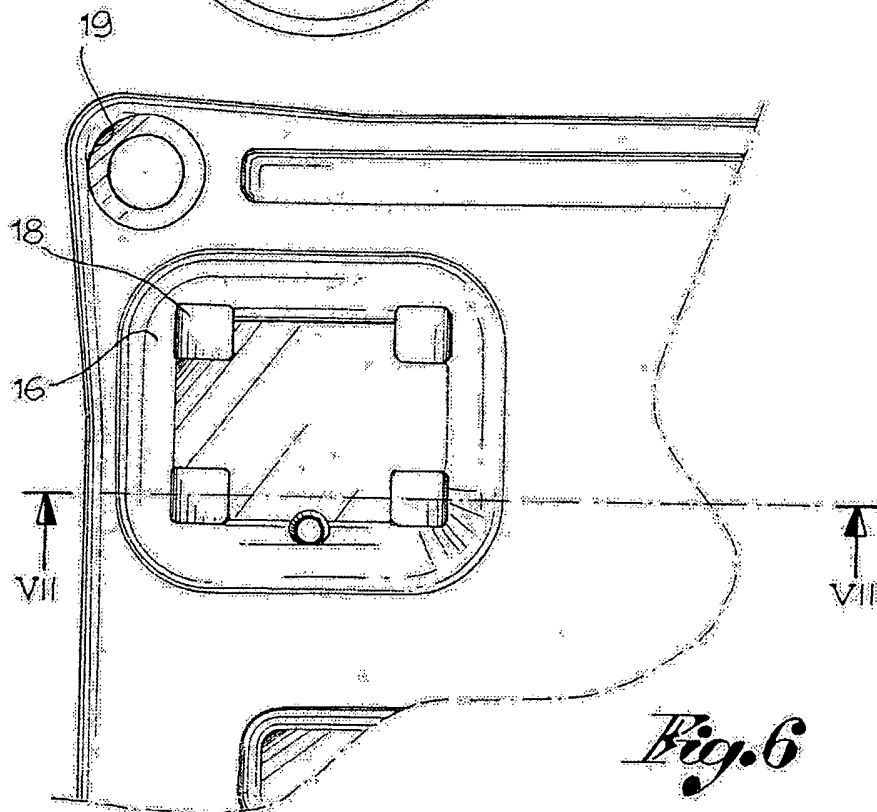

Fig. 6

INTERNATIONAL SEARCH REPORT

 Internat application No
 PCT/EP05/052380

 A. CLASSIFICATION OF SUBJECT MATTER
 IPC 7 B65D19/42

According to International Patent Classification (IPC) or to both national classification and IPC

B. FIELDS SEARCHED

 Minimum documentation searched (classification system followed by classification symbols)
 IPC 7 B65D

Documentation searched other than minimum documentation to the extent that such documents are included in the fields searched

Electronic data base consulted during the international search (name of data base and, where practical, search terms used)

EPO-Internal

C. DOCUMENTS CONSIDERED TO BE RELEVANT

Category *	Citation of document, with indication, where appropriate, of the relevant passages	Relevant to claim No.
X A	EP 0 487 147 A (CURTEC NEDERLAND BV) 27 May 1992 (1992-05-27) column 2, line 24 - column 3, line 51; figures 1,2	1-4, 13, 14, 16 5-12, 15, 17, 18
X A	GB 2 280 166 A (LIN PAC MOULDINGS) 25 January 1995 (1995-01-25) page 4, line 9 - page 5, line 29; figures 1,2	1-4, 13 5-12, 14-18
X A	DE 200 01 147 U (FEIL GMBH W) 7 June 2001 (2001-06-07) page 5, line 7 - page 7, line 16; figure 1	1-3, 13 4-12, 14-18
	----- -/--	

 Further documents are listed in the continuation of box C.

 Patent family members are listed in annex.

* Special categories of cited documents:

- *A* document defining the general state of the art which is not considered to be of particular relevance
- *E* earlier document but published on or after the international filing date
- *L* document which may throw doubts on priority claim(s) or which is cited to establish the publication date of another citation or other special reason (as specified)
- *O* document referring to an oral disclosure, use, exhibition or other means
- *P* document published prior to the international filing date but later than the priority date claimed

- *T* later document published after the international filing date or priority date and not in conflict with the application but cited to understand the principle or theory underlying the invention
- *X* document of particular relevance; the claimed invention cannot be considered novel or cannot be considered to involve an inventive step when the document is taken alone
- *Y* document of particular relevance; the claimed invention cannot be considered to involve an inventive step when the document is combined with one or more other such documents, such combination being obvious to a person skilled in the art.
- * & * document member of the same patent family

Date of the actual completion of the international search

23 September 2005

Date of mailing of the international search report

10/10/2005

Name and mailing address of the ISA

 European Patent Office, P.B. 5818 Patentlaan 2
 NL - 2280 HV Rijswijk
 Tel. (+31-70) 340-2040, Tx. 31 651 epo nl,
 Fax: (+31-70) 340-3016

Authorized officer

Lendfers, P

INTERNATIONAL SEARCH REPORT

Internal Application No
PCT/EP/2005/052380

C.(Continuation) DOCUMENTS CONSIDERED TO BE RELEVANT		
Category °	Citation of document, with indication, where appropriate, of the relevant passages	Relevant to claim No.
A	US 4 822 066 A (REHRIG HOUSTON) 18 April 1989 (1989-04-18) column 3, line 21 - column 3, line 45; figures 1,2 -----	1-18
A	GB 1 583 763 A (GPG INT LTD) 4 February 1981 (1981-02-04) page 1, line 75 - page 2, line 21; figure 1 -----	1-18

INTERNATIONAL SEARCH REPORT

Internal Application No
PCT/EP2005/052380

Patent document cited in search report		Publication date		Patent family member(s)	Publication date
EP 0487147	A	27-05-1992	NL	9002523 A	16-06-1992
GB 2280166	A	25-01-1995	NONE		
DE 20001147	U	07-06-2001	NONE		
US 4822066	A	18-04-1989	NONE		
GB 1583763	A	04-02-1981	NONE		