

[54] COMPOSITE SLIDEABLE DISPENSING CARTON

[75] Inventor: **Floyd L. Phillips, Jr.**,
Winston-Salem, N.C.

[73] Assignee: **R.J. Reynolds Tobacco Company**,
Winston-Salem, N.C.

[22] Filed: Dec. 7, 1972

[21] Appl. No.: 312,822

[52] U.S. Cl..... 206/254, 206/273, 229/20

[51] Int. Cl..... B65d 5/38, B65d 85/10

[58] Field of Search.... 206/41 R, 41 C, 41 D, 41 H,
206/41.2 R, 41.2 B, 45.11, 45.12, 45.15;
229/7 R, 11, 17 R, 20, 44 CB; 312/12

[56] **References Cited**
UNITED STATES PATENTS

381,889	4/1888	Scott	206/41.2 B
1,123,057	12/1914	Yardusky	229/20
1,791,340	2/1931	Bailey	206/41.2 B

1,928,889 10/1933 Guyer 229/20 UX

FOREIGN PATENTS OR APPLICATIONS

120,997 2/1948 Sweden..... 206/41 H

Primary Examiner—William I. Price
Assistant Examiner—Steven E. Lipman

[57] **ABSTRACT**

A composite dispensing carton is provided which includes an outer member closed at the bottom and open at the top, and an inner member mounted within the outer member for movement between extended and retracted positions relative to the outer member. The inner member is affixed to the outer member so as to restrict movement of the inner member to a predetermined extended position. The inner member is provided with a cover for closing the top of the outer member when said inner member is in said retracted position.

10 Claims, 7 Drawing Figures

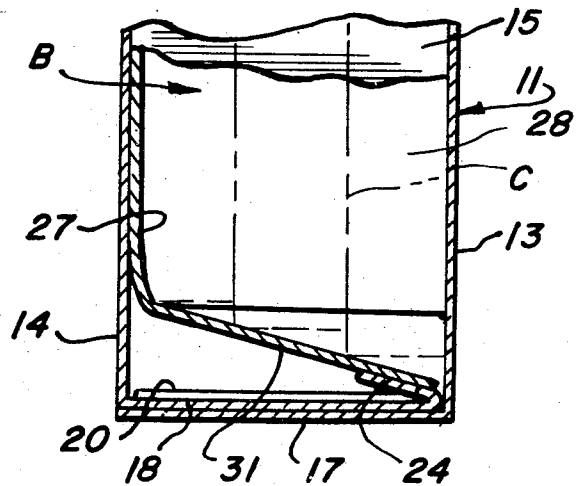
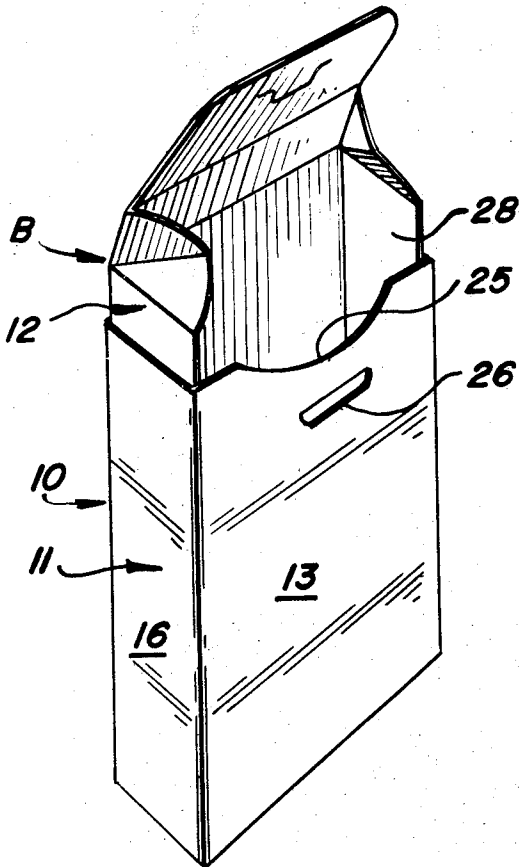

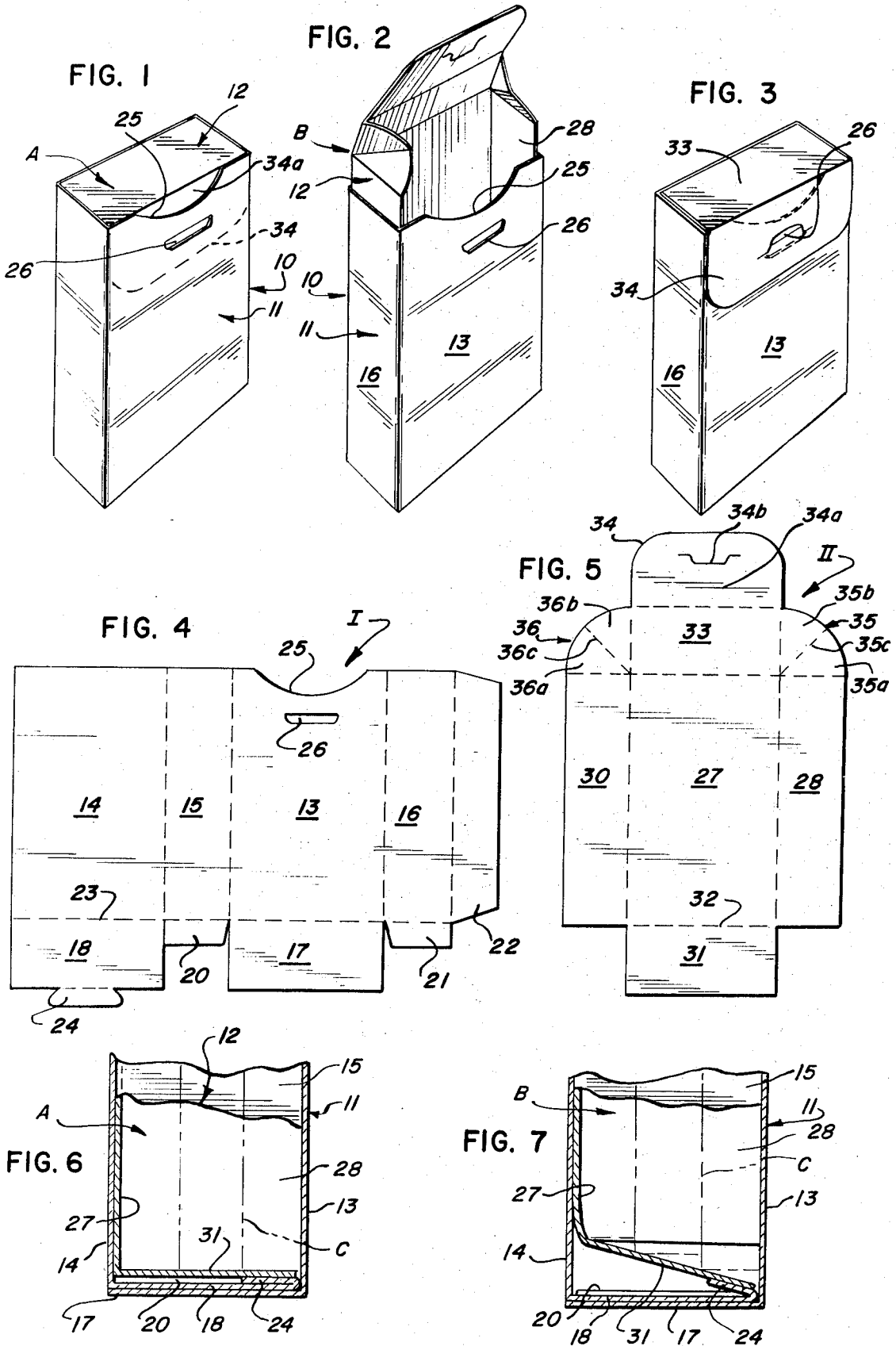

COMPOSITE SLIDEABLE DISPENSING CARTON

BACKGROUND OF THE INVENTION

Various composite dispensing cartons for cigarettes or the like have heretofore been provided; however, because of certain structural features they are beset with one or more of the following shortcomings: (a) the carton was of complex and costly construction; (b) the carton was not suitable for high speed filling; (c) the carton was awkward to manually open and could not be readily reclosed; (d) the carton did not provide adequate protection for the accommodated product; and (e) the carton was of bulky and fragile design.

SUMMARY OF THE INVENTION

Thus, it is an object of this invention to provide a composite dispensing carton which avoids the aforementioned shortcomings of the prior constructions.

It is a further object of the invention to provide a simple, compact and inexpensive carton which is attractive in appearance and may be readily manually opened and reclosed.

Further and additional objects will appear from the description, accompanying drawing and appended claims.

In accordance with one embodiment of the invention, a composite dispensing carton is provided which includes an outer sleeve member having a closed bottom and an open top, and an inner member mounted within said outer sleeve member for movement between extended and retracted positions. The lower end wall of the inner member is fixedly secured to a foldable tab carried by a lower end closure flap of the outer member, and thus, limits the extent to which the inner member can be extended relative to the outer member. The upper end of the inner member is provided with cover means which effects closing of the inner and outer members when the inner member is in a retracted position.

DESCRIPTION

For a more complete understanding of the invention, reference should be made to the drawing wherein:

FIG. 1 is a perspective top view of one form of the improved carton shown in its initial closed condition.

FIG. 2 is similar to FIG. 1, but showing the carton in open condition and the inner member fully extended relative to the outer member.

FIG. 3 is similar to FIG. 1, but showing the carton in a reclosed condition.

FIG. 4 is a top plan view of the blank for forming the outer member of the carton of FIG. 1.

FIG. 5 is a top plan view of the blank for forming the inner member of the carton of FIG. 1.

FIG. 6 is an enlarged, fragmentary vertical sectional view of the lower portion of the carton of FIG. 1 and showing the inner member in the retracted position and the contents of the carton in phantom lines.

FIG. 7 is similar to FIG. 6, but showing the inner member in the extended position.

Referring now to the drawing and more particularly to FIGS. 1 and 2, one form of the improved dispensing carton 10 is shown which is particularly suitable for accommodating cigarettes, cigars or the like. The carton 10 is of composite construction and includes an outer

sleeve member 11 and an inner tray member 12 which is mounted within member 11 for manual movement between retracted and extended positions A and B, respectively, see FIGS. 1 and 2. Outer member 11 is preferably formed from a blank I of foldable sheet material (e.g., paperboard), see FIG. 4 and inner member 12 is likewise formed from a blank II of similar foldable sheet material, see FIG. 5.

Outer member 11 is of sleeve-like configuration and includes a front panel 13, back panel 14, side panels 15 and 16, and closure flaps 17, 18, 20 and 21, the latter cooperating to form a closed bottom when the outer member is set up. As seen in FIG. 4, a glue flap 22 may be provided which will adhere to the interior surface of back panel 14 in conventional manner so as to retain the sleeve member in set up condition. The closure flaps are connected to the lower edges of the front, back, and side panels by segments of a foldline 23, see FIG. 4. Closure flaps 17 and 18 which are connected respectively to the front and back panels 13 and 14 of the illustrated carton are hereinafter sometimes referred to as major flaps, and the remaining closure flaps 20 and 21 connected respectively to the side panels 15 and 16 are sometimes referred to as minor flaps. Whether there are major and minor closure flaps will depend upon the configuration of the outer sleeve member. It will be noted in FIG. 4, that major flap 18 has foldably connected to the outer edge thereof a tab 24, the function of which will be described more fully hereinafter.

In setting up sleeve member 11, it is important that the closure flap 18, to which the tab 24 is connected, be the innermost of the overlapping flaps so that tab 24 will extend into the interior of the sleeve member, see FIGS. 6 and 7. Minor flaps 20 and 21 in the illustrated embodiment function as dust flaps and are subtended by the major flaps which are adhesively secured to one another, so as to form a sealed end closure.

The upper edge of the front panel 13 is recessed at 25 so as to facilitate initial opening of the carton. In addition to the recessed edge portion, a transversely extending slot 26 is formed in the front panel 13 adjacent to, but beneath the upper edge thereof.

The exposed surface of the outer member 11 may, if desired, be pre-printed and treated so as to become moisture-resistant. The blank I may be readily formed on conventional high speed scoring, slotting and slitting equipment, and may be set up by automatic means.

The inner member 12, in the illustrated carton, is of tray-like configuration and includes a base panel 27 which closely simulates the configuration of the back panel 14. The base panel 27 is in sliding engagement with the interior surface of back panel 14 and glue flap 22. Foldably connected to opposite elongated edges of base panel 27 are side flanges 28 and 30 which are in sliding engagement with the interior surfaces of the side panels 15 and 16, respectively, of the outer member. An end flange 31 is connected by foldline 32 to the lower edge of the base panel 27 of member 12. When the members 11 and 12 are assembled, the underside of flange 31, adjacent the outer edge thereof, is adhesively secured to the tab 24 carried by the major closure flap 18, see FIGS. 6 and 7.

When inner member 12 is in its retracted position A, end flange 31 is disposed substantially transversely of the base panel 27 and the side flanges 28 and 30. As seen in FIG. 6, when member 12 is in its retracted posi-

tion, the tab 24 is sandwiched between the end flange 31 of the inner member and the major closure flap 18 of the outer member.

Foldably connected to the upper edge of base panel 27 is a cover panel 33, the configuration of which closely simulates that of end flange 31. Foldably connected to the outer edge of the cover panel is a tuck flap 34. When the cover panel is in its initial closed position, as seen in FIG. 1, the tuck flap 34 is disposed behind the front panel 13 of the outer member and may be lightly secured thereto by adhesive, if desired. When the carton is to be initially opened, a slight amount of inwardly directed manual force is applied to the portion 34a of the tuck flap, which is exposed within the recessed upper edge portion 25 of the front panel 13, see FIG. 1, thereby causing the flap 34 to be freed from the front panel interior surface.

Tuck flap 34 is provided with a struckout tongue 34b which is adapted to interlock with slot 26 when the cover panel and tuck flap are in a reclosed position, as seen in FIG. 3. To lock or unlock the tongue from the slot 26 requires the tongue and the lower portion of the flap beneath the tongue to be manually folded outwardly.

The opposite lateral ends of cover panel 33 are connected to the adjacent ends of the side flanges 28 and 30 by a pair of foldable gusset flaps 35 and 36, respectively. Each flap is of like configuration and includes a pair of substantially circular sector shaped sections 35a and b and 36a and b. The sections comprising each pair are connected by a common foldline 35c or 36c. The inner end of each foldline terminates at an upper corner of the base panel, see FIG. 5. The opposite sides of sections 35a and 36a are foldably connected to the upper edges of side flanges 28 and 30, respectively. The remaining sections 35b and 36b, in turn, are foldably connected to opposite lateral ends of cover panel 33. The arrangement of the foldlines connecting the pairs of sections to the cover panel and side flanges is such that when the cover panel 33 is moved to its closed position, see FIG. 1, the sections of each pair will fold inwardly and subtend the undersurface of the cover panel. Thus, each folded gusset flap 35 and 36 functions as a dust flap when the carton is initially closed or reclosed. Because of the inherent fight-back of the blank material to folding, the folded gusset flaps urge the cover panel to assume an open position, and thus, a positive interlocking between the struckout tongue 34b and the slot 26 is maintained.

While the inner member 12 is shown and described as a tray-like member, it is not intended to limit the claimed invention thereto. Rather than having an open side opposite the base panel, said side could be closed so as to form a sleeve-like unit.

In FIGS. 6 and 7 the illustrated carton is shown accommodating a plurality of cigarettes C, indicated by phantom lines. The cigarettes are fully enclosed within the carton when the inner member assumes the retracted position A and the cover panel 33 is in its initial closed or reclosed position. When, however, the inner member assumes its extended position B, causing the end flange 31 to be obliquely disposed, the accommodated cigarettes will be raised a graduated amount so that the upper ends thereof will project upwardly beyond the open top of the outer member 11. While the cigarettes are in their upwardly projecting positions, individual cigarettes may be readily removed manually

from the carton without disturbing those remaining in the carton.

In filling the improved carton, one suggested procedure may be as follows: (a) a predetermined number of cigarettes arranged in stacked relation are positioned on the base panel 27; (b) the side and end flanges and the cover panel are folded upright so as to retain the stack of cigarettes in registration on the base panel; (c) the tuck flap 34 is folded over the top of the stack; (d) the outer member with both ends open is set up to form a sleeve; (e) the folded cover panel, gusset flaps and tuck flap of the loaded tray member are inserted into the sleeve member through the open bottom end thereof until the exposed surface of the cover panel is flush with the open top of the outer member; and (f) adhesive is applied to tab 24 and the underside of major flap 18 and then the closure flaps and tab are folded relative to one so as to close the bottom of the outer sleeve and at the same time have the tab 24 become adhesively affixed to the underside of end flange 31. The foregoing procedural steps may be accomplished by conventional high speed automatic packaging equipment. Other procedures, however, may obviously be employed, if desired, in filling and setting up the improved carton.

Thus, it will be seen that an improved dispensing carton has been provided which is highly suitable for accommodating cigarettes or the like, and is of simple, compact, sturdy and inexpensive construction. The improved carton may be readily formed, set up and loaded by conventional high speed equipment. The improved carton permits one or more cigarettes to be readily removed at one time without requiring abrupt manual manipulation of the package.

I claim:

1. A composite dispensing carton comprising an outer sleeve member and an inner member mounted within said outer member for sliding movement between extended and retracted positions; said outer member including front and back panels, side panels interconnecting same, and closure flaps foldably connected to said panels, said closure flaps overlapping one another to form a bottom for said outer member, one of said closure flaps being exposed to the interior of said outer member and being provided with an inwardly extending foldable tab; said inner member including a base panel engaging the interior surface of said outer member back panel, side flanges connected to opposite sides of said base panel and engaging the interior surfaces of said outer member side panels, an end flange disposed intermediate of and separated from said side flanges and foldably connected to said base panel, said end flange being connected to the tab of said outer member whereby the extended position of said inner member relative to said outer member is limited by the connection between said end flange and said tab; and cover means connected to said base panel and disposed opposite said end flange for closing the end of said inner member and the upper end of the outer member when said inner member is in the retracted position.

2. The composite dispensing carton of claim 1 wherein the tab is sandwiched between the closure flap to which it is foldably connected and the end flange when said inner member is in said retracted position.

3. The composite dispensing carton of claim 2 wherein said end flange assumes a substantially trans-

5

verse position relative to said base panel when said inner member is in said retracted position, and said end flange assumes an oblique position relative to said base panel when said inner member is in said extended position.

4. The composite dispensing carton of claim 3 wherein said outer sleeve member is formed from a first blank of foldable sheet material, and said inner member is formed from a second blank of foldable sheet material.

5. The composite dispensing carton of claim 1 wherein said cover means includes a cover panel foldably connected to said base panel and foldable gusset flaps interconnecting peripheral portions of said cover panel with adjacent peripheral portions of said side flanges; each gusset flap being foldable inwardly and subtending said cover panel when the latter is closing the end of said inner member.

6. The composite dispensing carton of claim 1 wherein said cover means includes a cover panel having a first edge foldably connected to said base panel and a tuck flap foldably connected to a second edge of said cover panel, said first and second edges being opposite one another, said tuck flap engaging the interior surface of said outer member front panel when said cover means is in initial closing relation with respect to the upper end of said outer sleeve member.

6

7. The composite dispensing carton of claim 6 wherein said tuck flap is provided with a struckout tongue, and said outer member front panel is provided with a slot, said tongue interlockingly engaging said slot when said cover means is in a reclosing relation with respect to the upper end of said outer member.

8. The composite dispensing carton of claim 1 wherein the base panel of said inner member is in substantially coincident relation with the back panel of said outer member when said inner member is in said retracted position.

9. The composite dispensing carton of claim 1 wherein the closure flaps of said outer member include major flaps foldably connected to the lower edges of said front and back panels, and minor flaps foldably connected to the lower edges of the side panels; said major flaps being secured in overlapping relation and said foldable tab being connected to the innermost of the overlapping major flaps.

10. The composite dispensing carton of claim 9 wherein the innermost major flap has one side thereof foldably connected to the lower edge of the back panel of said outer member and the foldable tab is connected to the opposite side of said innermost major flap, said tab being disposed adjacent the interior surface of the front panel of said outer member.

* * * * *

30

35

40

45

50

55

60

65

UNITED STATES PATENT OFFICE
CERTIFICATE OF CORRECTION

Patent No. 3,828,923

Dated August 13, 1974

Inventor(s) Floyd L. Phillips, Jr.

It is certified that error appears in the above-identified patent and that said Letters Patent are hereby corrected as shown below:

Column 2, line 35, "Figs. 6 and 7" should be --Figs. 6 or 7--

Column 3, " 27, "quset" should be --gusset--

Column 3, " 43, "flap 35 and 36" should be --flap 35 or
36--

Signed and sealed this 5th day of November 1974.

(SEAL)
Attest:

McCOY M. GIBSON, JR.
Attesting Officer

C. MARSHALL DANN
Commissioner of Patents