



(51) International Patent Classification:

F21V 21/06 (2006.01) F21V 21/26 (2006.01)
F21V 21/22 (2006.01)

(21) International Application Number:

PCT/US2018/054658

(22) International Filing Date:

05 October 2018 (05.10.2018)

(25) Filing Language:

English

(26) Publication Language:

English

(30) Priority Data:

62/569,317 06 October 2017 (06.10.2017) US

(71) Applicant: **MILWAUKEE ELECTRIC TOOL CORPORATION** [US/US]; 13135 West Lisbon Road, Brookfield, WI 53005 (US).

(72) Inventors: **ADAMS, Josh**; 2929 N. 89th Street, Milwaukee, WI 53222 (US). **DOBERSTEIN, Emily, C.**; 13127 Kellam Court, #31, San Diego, CA 92130 (US). **MCINTYRE, Ross**; 1626 N. Prospect Avenue, Apt. 706, Milwaukee, WI 53202 (US). **PROEBER, David**; 2766 N. 88th Street, Milwaukee, WI 53222 (US). **WENZEL, Duane, W.**; 422 S. Hine Avenue, Waukesha, WI 53188 (US).

(74) Agent: **TRAUTSCHOLD, David, J.** et al.; Michael Best & Friedrich LLP, 100 East Wisconsin Avenue, Suite 3300, Milwaukee, WI 53202-4108 (US).

(81) Designated States (unless otherwise indicated, for every kind of national protection available): AE, AG, AL, AM, AO, AT, AU, AZ, BA, BB, BG, BH, BN, BR, BW, BY, BZ, CA, CH, CL, CN, CO, CR, CU, CZ, DE, DJ, DK, DM, DO, DZ, EC, EE, EG, ES, FI, GB, GD, GE, GH, GM, GT, HN, HR, HU, ID, IL, IN, IR, IS, JO, JP, KE, KG, KH, KN, KP, KR, KW, KZ, LA, LC, LK, LR, LS, LU, LY, MA, MD, ME, MG, MK, MN, MW, MX, MY, MZ, NA, NG, NI, NO, NZ, OM, PA, PE, PG, PH, PL, PT, QA, RO, RS, RU, RW, SA, SC, SD, SE, SG, SK, SL, SM, ST, SV, SY, TH, TJ, TM, TN, TR, TT, TZ, UA, UG, US, UZ, VC, VN, ZA, ZM, ZW.

(84) Designated States (unless otherwise indicated, for every kind of regional protection available): ARIPO (BW, GH, GM, KE, LR, LS, MW, MZ, NA, RW, SD, SL, ST, SZ, TZ, UG, ZM, ZW), Eurasian (AM, AZ, BY, KG, KZ, RU, TJ, TM), European (AL, AT, BE, BG, CH, CY, CZ, DE, DK, EE, ES, FI, FR, GB, GR, HR, HU, IE, IS, IT, LT, LU, LV, MC, MK, MT, NL, NO, PL, PT, RO, RS, SE, SI, SK, SM, TR), OAPI (BF, BJ, CF, CG, CI, CM, GA, GN, GQ, GW, KM, ML, MR, NE, SN, TD, TG).

(54) Title: STAND LIGHT

(57) Abstract: A stand light includes a telescoping body having a main center shaft, an extension pole extendable out of the main center shaft, and a sleeve movably supported on the main center shaft. A head assembly is supported by the extension pole and includes a light source. A plurality of legs is pivotally coupled to the body and is movable with the sleeve from a collapsed position to an extended position, in which distal ends of the plurality of legs are moved away from the body. When the plurality of legs is in the collapsed position, side portions of the plurality of legs come together to form a handle configured to be grasped by a user.

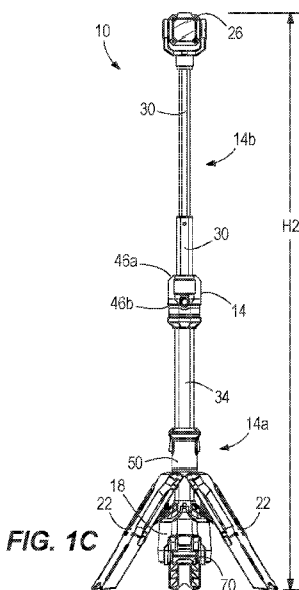

WO 2019/071159 A1

Published:

- *with international search report (Art. 21(3))*
- *before the expiration of the time limit for amending the claims and to be republished in the event of receipt of amendments (Rule 48.2(h))*

STAND LIGHT

CROSS-REFERENCE TO RELATED APPLICATIONS

[0001] This application claims priority to U.S. Provisional Patent Application No. 62/569,317, filed October 6, 2017, the entire contents of which are incorporated by reference herein.

FIELD OF THE INVENTION

[0002] The present invention relates to work lights and, more particularly, to work lights including foldable stands.

SUMMARY

[0003] In one aspect, the invention provides a stand light including a telescoping body having a main center shaft, an extension pole extendable out of the main center shaft, and a sleeve movably supported on the main center shaft. The stand light also includes a head assembly supported by the extension pole. The head assembly includes a light source. The stand light further includes a plurality of legs pivotally coupled to the body. The plurality of legs is movable with the sleeve from a collapsed position to an extended position, in which distal ends of the plurality of legs are moved away from the body. A first of the plurality of legs includes a main portion and an aperture extending through the main portion to form a side portion. A second of the plurality of legs includes a main portion and an aperture extending through the main portion to form a side portion. When the plurality of legs is in the collapsed position, the side portion of the first of the plurality of legs and the side portion of the second of the plurality of legs come together to form a handle configured to be grasped by a user.

[0004] In another aspect, the invention provides a stand light including a telescoping body having a main center shaft, an extension pole extendable out of the main center shaft, and a sleeve movably supported on the main center shaft. The stand light also includes a head assembly supported by the extension pole. The head assembly includes a support arm, a light head coupled to the support arm, and a light source coupled to the light head. The stand light further includes a plurality of legs pivotally coupled to the body. The plurality of legs is movable with the sleeve from a collapsed position to an extended position, in which distal ends of the plurality of legs are moved away from the body. The stand light also includes a

light shroud coupled to an end of the main center shaft. The light shroud includes notches formed on inner surfaces of sidewalls of the light shroud. The notches receive portions of the support arm when the head assembly is in a lowest resting position, in which the light head rests on top of the light shroud.

[0005] In yet another aspect, the invention provides a stand light including a telescoping body having a main center shaft, an extension pole extendable out of the main center shaft, and a sleeve movably supported on the main center shaft. The stand light also includes a head assembly supported by the extension pole. The head assembly includes a support arm, a light head coupled to the support arm, and a light source coupled to the light head. The stand light further includes a plurality of legs pivotally coupled to the body. The plurality of legs is movable with the sleeve from a collapsed position to an extended position, in which distal ends of the plurality of legs are moved away from the body. The body also includes a detent mechanism having a first detent member coupled to an upper end of the main center shaft and a second detent member coupled to a lower end of the extension pole. The first detent member engages the second detent member to releasably secure the extension pole in a maximum extended position.

[0006] Other aspects of the invention will become apparent by consideration of the detailed description and accompanying drawings.

BRIEF DESCRIPTION OF THE DRAWINGS

[0007] Figs. 1A is a side view of a stand light in a collapsed position, the stand light including legs and a head assembly.

[0008] Fig. 1B is a side view of the stand light with the legs in an extended position.

[0009] Fig. 1C is a side view of the stand light with the legs in the extended position and the head assembly in an extended position.

[0010] Figs. 2A-2D are side views of the stand light of Figs. 1A-1C in the collapsed position.

[0011] Fig. 3 is a side view of the stand light of Figs. 1A-1D in an extended position.

[0012] Fig. 4 is a cross-sectional view of the stand light in the collapsed position.

- [0013] Fig. 5 is a cross-sectional view of a portion of the stand light.
- [0014] Fig. 6 is a side view of a shroud and the head assembly of the stand light.
- [0015] Fig. 7 is an enlarged view of a main housing of the stand light, illustrating a power outlet port.
- [0016] Fig. 8 is a perspective view of a lower portion of the stand light, illustrating the legs in the extended position and an extension cord connected to the power port.
- [0017] Fig. 9 is a side view of the lower portion of the stand light, illustrating a battery pack connected to the main housing.
- [0018] Fig. 10 is a perspective view of the lower portion of the stand light, illustrating the battery pack removed from the main housing.
- [0019] Fig. 11 is a perspective view of the lower portion of the stand light, illustrating the legs forming a handle.
- [0020] Fig. 12A is a front view of the head assembly of the stand light.
- [0021] Fig. 12B is a rear view of the head assembly of the stand light.
- [0022] Fig. 12C is a side view of the head assembly of the stand light.
- [0023] Fig. 13 is a top perspective view of the head assembly and the shroud of the stand light.
- [0024] Fig. 14 is a side view of the head assembly and the shroud of the stand light, with the head assembly in a lowest resting position.
- [0025] Fig. 15 is a cross-sectional view of the head assembly and the shroud.
- [0026] Fig. 16 is an exploded view of extension poles and a main center shaft of the stand light.
- [0027] Fig. 17 is a front perspective view of one of the legs of the stand light.
- [0028] Fig. 18 is a rear perspective view of one of the legs of the stand light.

[0029] Fig. 19 is a top perspective view of the shroud and the head assembly with a light head removed.

[0030] Fig. 20 is a cross-sectional view of the shroud and the head assembly with the light head removed.

DETAILED DESCRIPTION

[0031] Before any embodiments of the invention are explained in detail, it is to be understood that the invention is not limited in its application to the details of construction and the arrangement of components set forth in the following description or illustrated in the following drawings. The invention is capable of other embodiments and of being practiced or of being carried out in various ways.

[0032] Figs. 1A-3 illustrate a stand light 10 according to one embodiment of the invention. The illustrated stand light 10 includes a body 14, a main housing 18, legs 22, and a head assembly 26. The stand light 10 is movable between a collapsed position (Figs. 1A and 2A-2D) and multiple extended positions (Figs. 1B, 1C, and 3). When in the collapsed position, the stand light 10 is relatively compact for storage and transport. When in one of the extended positions, the legs 22 of the stand light 10 are expanded so that the light 10 is self-supporting on a surface and the head assembly 26 may be extended away from the body 14.

[0033] The illustrated body 14 is a telescoping body that includes extension poles 30 and a main center shaft 34 that allow the body 14 to extend in length. In the illustrated embodiment, the body 14 includes two extension poles 30 that slide into and out of the center shaft 34 and relative to each other to extend the length of the body 14. In other embodiments, the body 14 may include more than two extension poles 30. As shown in Figs. 1A and 1C, the body 14 extends from a first, minimum height H1 (i.e., a collapsed position, Fig. 1A) to a second, maximum height H2 (i.e., an extended position, Fig. 1C). While in the collapsed position, the first height H1 is the most compact at approximately 30 inches, and while in the extended position, the second height H2 is approximately 60 inches. When in the collapsed position, the extension poles 30 are disposed in the main center shaft 34. The main center shaft 34 has the same cross-sectional shape as the extension poles 30 with a larger diameter, and allows the extension poles 30 to nest therein. In the illustrated embodiment, the main

center shaft 34 and the extension poles 30 have generally hexagonal-shaped cross-sections. In other embodiments, the main center shaft 34 and the extension poles 30 may have other suitable cross-sectional shapes to inhibit relative rotation between the main center shaft 34 and the extension poles 30 (e.g., square, D-shaped, oblong, etc.), or the main center shaft 34 and the extension poles 30 may have generally circular cross-sections with anti-rotation features (e.g., ribs and grooves).

[0034] As shown in Fig. 16, the body 14 includes a detent mechanism to releasably secure the extension poles 30 in a maximum extended position. The illustrated detent mechanism includes a first detent member 200 coupled to an upper end of the main center shaft 34, a second detent member 204 coupled to a lower end of the middle extension pole 30, a third detent member 208 coupled to an upper end of the middle extension pole 30, and a fourth detent member 212 coupled to a lower end of the inner extension pole 30. The detent mechanism may include fewer or more detent members, depending on the number of extension poles 30. The first detent member 200 is secured to an inner surface of the main center shaft 34 and includes fingers 216 having enlarged heads. The second detent member 204 is secured to an outer surface of the middle extension pole 30 and defines recesses 220 configured to receive the enlarged heads of the fingers 216. The third detent member 208 is secured to an inner surface of the middle extension pole 30 and includes fingers 224 having enlarged heads. The fourth detent member 212 is secured to an outer surface of the inner extension pole 30 and defines recesses 228 configured to receive the enlarged heads of the fingers 224.

[0035] In operation, as the middle extension pole 30 is slid relative to the main center shaft 34 to move the lower end of the middle extension pole 30 adjacent the upper end of the main center shaft 34, the fingers 216 of the first detent member 200 contact the second detent member 204. The shape of the second detent member 204 causes the fingers 216 to deflect until the fingers 216 snap into the recesses 220 of the second detent member 204. In this position, the middle extension pole 30 is releasably secured in the extended position relative to the main center shaft 34. The fingers 216 can be released from the recesses 220 by exerting sufficient force to collapse the middle extension pole 30.

[0036] Similarly, as the inner extension pole 30 is slid relative to the middle extension pole 30 to move the lower end of the inner extension pole 30 adjacent the upper end of the middle extension pole 30, the fingers 224 of the third detent member 208 contact the fourth

detent member 212. The shape of the fourth detent member 212 causes the fingers 224 to deflect until the fingers 224 snap into the recesses 228 of the fourth detent member 212. In this position, the inner extension pole 30 is releasably secured in the extended position relative to the middle extension pole 30. The fingers 224 can be release from the recesses 228 by exerting sufficient force to collapse the inner extension pole 30. With such an arrangement, the body 14 does not include manual actuators (e.g., cam locks) to release and secure the extensions poles 30 for sliding movement.

[0037] The body 14 can also extend to and be retained at any height (i.e., an intermediate position) between the first height (i.e., the collapsed position) and the second height (i.e., the maximum extended position). The extension poles 30 are maintained in position relative to each and to the main center shaft 34 by friction. In particular, the illustrated second detent member 204 and fourth detent member 212 include outwardly-projecting surfaces 232, 236 that engage inner surfaces of the main center shaft 34 and the middle extension pole 30 as the extension poles 30 are extended and collapsed. The outwardly-projecting surfaces 232, 236 create sufficient force to maintain the extension poles 30 in intermediate positions against the force of gravity. The first detent member 200 and the second detent member 208 may also or alternatively include inwardly-projecting surfaces that engage outer surfaces of the extensions poles 30 to maintain the extension poles in intermediate positions. In other embodiments, the body 14 may include additional detent members to releasably secure the extension poles 30 in discrete intermediate positions.

[0038] Alternative mechanisms may additionally be implemented in order to hold the extension poles 30 in place. For example, the poles 30 may include friction plates to inhibit the poles 30 from falling due to gravity, but that could be overcome with sufficient force by a user. In further embodiments, the extension poles 30 may include a cam adjustment mechanism to selectively tension and release two or more poles 30 of the body 14 to allow adjustment of height. In some embodiments, plastic spacers may be positioned between the extension poles 30 to create friction so the extension poles 30 will not automatically retract when the cam adjustment is opened.

[0039] In alternative embodiments, one extension pole 30 may include an actuator (e.g., button), and another extension pole 30 of a larger diameter may include a recess. When the extension poles 30 are extended to a desired length, the actuator may engage the recess, locking the poles 30 in place. In order to collapse the poles 30, a user may depress the

actuator, thereby releasing the actuator from engagement with the recess and collapsing the light assembly 10. In still another embodiment, the extension poles 30 may include only a friction plate to maintain the poles 30 position with infinite adjustment.

[0040] As shown in Fig. 4, an electrical cord 32 is positioned within and extends through the extension poles 30. The electrical cord 32 connects the head assembly 26 to the main housing 18 to provide power to the head assembly 26. More specifically, the electrical cord 32 extends between the light head assembly 26 and a circuit board 40 of the light 10. In the illustrated embodiment, the electrical cord 32 includes a coiled portion 36. The coiled portion 36 wraps a rigid guide tube 44 extending throughout the extension poles 30 and allows the cord 32 to expand and contract during extension and collapsing of the light stand 10. For example, when the light 10 is moved into one of the extended positions, the coiled portion 36 of the electrical cord 32 may expand, and when the light 10 is moved into the collapsed position, the coiled portion 36 of the electrical cord 32 may retract. The rigid guide tube 44 provides support for the coiled portion 36 so the coiled portion 36 does not bend out of alignment or kink during extension and retraction. Additionally, the coiled portion 36 allows for the light head assembly 26 to be rotated without causing substantial damage to the cord 32.

[0041] As shown in Figs. 2A-2D and 6, the body 14 includes a light shroud 46 secured to the main center shaft 34 at a fixed distance from the main housing 18. The extension poles 30 extend from a first end 46a of the light shroud 46 and the main center shaft 34 extends from a second end 46b of the light shroud 46. The first end 46a of the light shroud 46 defines an area for supporting the head assembly 26. More specifically, the first end 46a of the light shroud 46 includes cutouts 48, or apertures, positioned on opposite sides of the shroud 46. The cutouts 48 extend through the first end 46a of the shroud 46 and are shaped to receive and provide clearance for arms 102 of the light head assembly 26 when the light 10 is in the collapsed position. As such, when the light 10 is collapsed, the light head assembly 26 is seated within and partially surrounded by the shroud 46. In alternative embodiments, the shroud 46 may fully surround the arms 102 of the light head assembly 26 rather than providing cutouts 48. In still further embodiments, the first end 46a of the light shroud 46 may include mechanisms (e.g., latches, detents, notches, etc.) for releasably securing the head assembly 26 within the shroud 46 when the stand light 10 is fully collapsed. In some embodiments, the head assembly 26 and the shroud 46 may be keyed to one another to

position the head assembly 26 relative to the shroud 46 and to inhibit the head assembly 26 from rotating relative to the shroud 46.

[0042] As shown in Figs. 2A-2D and 3, the body 14 further includes a sleeve 50. The sleeve 50 surrounds a portion of the main center shaft 34 and is movable relative to the main center shaft 34. In the illustrated embodiment, the sleeve 50 is slidable along the main center shaft 34 toward and away from the light shroud 46. Ends of the legs 22 are coupled to the sleeve 50 for movement with the sleeve 50 between extended and collapsed positions. When the stand light 10 moves to the extended position, the sleeve 50 moves axially away from the light shroud 46, causing the legs 22 to move away from the main housing 18. When the stand light 10 moves to the collapsed position, the sleeve 50 moves axially toward the light shroud 46, causing the legs 22 to move toward the main housing 18.

[0043] As shown in Fig. 5, the sleeve 50 includes one or more actuators 54. In the illustrated embodiment, the sleeve 50 includes two actuators 54 positioned on opposite sides of the sleeve 50. The illustrated actuators 54 are buttons that are movably coupled to the sleeve 50, but may alternatively be other types of suitable actuators. The actuators 54 are pivotable relative to the sleeve 50 about pivot axes defined by corresponding pivot pins 60. The actuators 54 are operable to hold the stand light 10 in either the collapsed position or one of the extended positions. Each actuator 54 includes a projection 52. The projections 52 are configured to engage apertures 56 formed in the main center shaft 34. The illustrated actuators 54 are biased into engaged positions so the projections 52 are received in the apertures 56, but are manually actuatable (e.g., depressible) to move the projections 52 out of the apertures 56. In the illustrated embodiment, the actuators 54 are biased by leaf springs 57. In other embodiments, the actuators 54 may be biased by other suitable springs, such as torsion springs, compressions springs, and the like.

[0044] When the light 10 is in the collapsed position so the sleeve 50 is adjacent the light shroud 46 (Fig. 1A), the projections 52 extend into apertures 56 formed in the main center shaft 34 near the light shroud 46 to lock the sleeve 50 in the collapsed position. The actuators 54 may be actuated to disengage the projections 52 from the apertures 56, allowing the sleeve 50 to slide along the main center shaft 34 away from the light shroud 46 and causing the legs 22 to move toward the extended position. When the light 10 is in the extended position so the sleeve 50 is adjacent the main housing 18 (Fig. 1B), the projections 52 extend into apertures 56 formed in the main center shaft 34 near the main housing 18 to lock the sleeve

50 in the extended position. The actuators 54 may again be actuated to disengage the projections 52 from the apertures 56, allowing the sleeve 50 to slide along the main center shaft 34 toward the light shroud 46 and causing the legs 22 to move toward the collapsed position.

[0045] To disengage the projections 52 from the apertures 56 and move the sleeve 50, both actuators 54 need to be actuated at the same time. In the illustrated embodiment, the actuators 54 are positioned on diametrically opposite sides of the sleeve 50, but are designed so a user can engage and actuate both actuators 54 simultaneously with a single hand. For example, the actuators 54 have relatively large engagement areas that can be depressed by a user's thumb, a user's fingers, and/or a user's palm to actuate the actuators 54. With such an arrangement, a user can grasp the sleeve 50 and actuate the actuators 54 with one hand, while grasping the light shroud 46 (or other suitable structure of the light 10) with the other hand, to move the sleeve 50 along the main center shaft 34, thereby extending or collapsing the legs 22.

[0046] As illustrated in Fig. 6, the light 10 further includes a fuel gauge 58 and a power button 62. The illustrated fuel gauge 58 and power button 62 are supported on the light shroud 46. In other embodiments, the fuel gauge 58 and the power button 62 may alternatively be positioned elsewhere on the light 10.

[0047] The fuel gauge 58 includes lights or LEDs 66 to display an amount of charge remaining in a battery pack 70 (Figs. 1A-1C) connected to the light 10. In the illustrated embodiment, the fuel gauge 58 includes four LEDs 66 to indicate four different charge levels of the battery pack 70. For example, four illuminated LEDs 66 may indicate a battery charge status of 100%, three illuminated LEDs 66 may indicate a battery charge status of 75%, two illuminated LEDs 66 may indicate a battery charge status of 50%, one illuminated LED 66 may indicate a battery charge status of 25%, and zero illuminated LEDs 66 may indicate a battery charge status of 0%.

[0048] The power button 62 is operable to change the light 10 between various states, such as high power, low power, and off. In the illustrated embodiment, depressing the power button 62 for a predetermined, extended period of time will turn off the stand light 10, no matter which state is activated as the power button 62 is depressed. In further embodiments, the light 10 may include more or less than two additional states. For example, the light 10

may include a separate actuator to change the light between various intensity states. In further alternative embodiments, the light 10 may include an intensity indicator to display which the intensity state of the light 10.

[0049] As shown in Figs. 3 and 7-10, the main housing 18 is supported at a first end 14a of the body. The main housing 18 is configured to support the battery pack 70 to power the light 10. More specifically, the main housing 18 includes a battery receptacle 78 for receiving the battery pack 70. In the illustrated embodiment, the battery pack 70 is a rechargeable power tool battery pack, such as a 12V Li-ion battery pack.

[0050] As shown in Figs. 7 and 8, the main housing 18 further includes a power port 74. The illustrated power port 74 is an input port, such as an AC power input port. The power port 74 can connect to, for example, an extension cord 76 for powering the light 10 via an AC power source. In some embodiments, the main housing 18 may also or alternatively include a power output port. The output port allows another device (e.g., a light, a power tool, etc.) to be plugged into the light 10 to power the another device. In such embodiments, multiple devices can be daisy-chained together.

[0051] As shown in Fig. 10, the illustrated main housing 18 also supports a charging circuit 80. The charging circuit 80 electrically couples the power inlet port 74 to the battery pack 70 to charge the battery pack 70. If both the battery pack 70 and an AC power source are connected to the light, the AC power source will charge the battery pack 70 and power the light 10. When the AC power source is disconnected from the light 10, the battery pack 70, if sufficiently charged, will automatically begin powering the light 10.

[0052] Referring back to Figs. 1A-1C, the legs 22 are pivotally coupled to the body 14 for movement between the collapsed position (Fig. 1A) and the extended position (Figs. 1B and 1C). More particularly, a first or proximal end of each leg 22 is pivotally coupled to the sleeve 50, and a second or distal end of each leg 22 is configured to contact the ground or other surface supporting the light 10. As the legs 22 move from the collapsed position to the extended position, the distal ends of the legs 22 move away from the body 14. In the illustrated embodiment, the stand light 10 includes three legs 22. In other embodiments, the stand light 10 may include fewer or more legs 22. In some embodiments, the legs 22 can telescope to lengthen or shorten independently of one another. For example, when the light

10 is placed on an uneven surface, each leg 22 can adjust to a different length in order to support the light 10.

[0053] As shown in Figs. 8 and 10, a leg link 82 extends between each of the legs 22 and the body 14 to limit the movement of the legs 22. In the illustrated embodiment, the leg links 82 are wireforms. The leg links 82 extend from the backside of the legs 22 to a flange 84 protruding from the main body 18. Each of the legs 22 includes two leg links 82 such that each leg link 82 extends from either side of the flange 84. In some embodiments, each set of two leg links 82 may be integrally formed as a U-shaped leg link.

[0054] At least one of the legs 22 includes a recess 92, or cutout, formed in the distal end of the leg 22. The recess 92 provides clearance for the extend cord 76 (Fig 8) to pass under the leg 22 and connect to the power inlet port 74. Specifically, at least the leg 22 aligned on the same side of the light 10 as the power inlet port 74 includes the recess 92. In the illustrated embodiment, all three legs 22 include recesses 92. In other embodiments, only one or some of the legs 22 may include the recess 92.

[0055] As shown in Fig. 11, each of the legs 22 includes a central portion 96 extending down the center of the leg 22 and two apertures 90 spaced on either side of the central portion 96. The apertures 90 extend through the leg 22 and form side portions 100 extending away from the body 14. More specifically, the central portion 96 and side portions 100 are angled, or curved, away from the main body 14, such that the apertures 90 are large enough to receive a user's hand. When in the collapsed position, the side portions 100 of two adjacent legs 22 are brought next to each other to form one, continuous leg handle 94. A user may slide her hand through one of the apertures 90 of each adjacent leg 22 and grasp the handle 94 in order to carry the light 10. Because the handle 94 is formed from two separate legs 22, the user holding the handle 94 causes the legs 22 to remain in the collapsed position. In other words, the two adjacent legs 22 cannot move apart from each and toward the extended position.

[0056] In the illustrated embodiment, each of the legs 22 includes a main portion 96, two apertures 90, and two side portions 100. Therefore, when the light 10 is in the collapsed position, the light 10 includes three separate handles 94 formed by pairs of adjacent legs 22. The handles 94 are spaced apart circumferentially around the body 14. However, in alternative embodiments, only two of the legs 22 may include a main portion 96, apertures

90, and two side portions 100, therefore creating only one handle 94. In alternative embodiments, the legs 22 may additionally or alternatively include a handle formed only on one of the legs 22.

[0057] Figs. 17 and 18 illustrate one of the legs 22 in more detail. Each side portion 100 includes a grip surface having features (e.g., ribs) configured to facilitate grasping and carrying the light 10 by the handles 94. In addition, the main portion 96 includes apertures 101 that receive ends of the corresponding leg link 82. A projection 103 is formed on the inner surface of the main portion 96, between the apertures 101. The projection 103 helps maintain the leg link 82 within the apertures 101 when, for example, the legs 22 are in the collapsed position for storage or transport. In particular, the projection 103 blocks the leg link 82 from bending or deflecting inward and popping out of the apertures 101. In the illustrated embodiment, the projection 103 is integrally formed as a single piece (e.g., molded) on the inner surface of the leg 22. In other embodiments, the projection 103 may be a separately piece that is permanently coupled to the inner surface of the leg 22.

[0058] In alternative embodiments, the legs 22 of the light 10 may automatically deploy by a release mechanism triggered when the main housing 18 is set on a support surface. Using the release mechanism or an alternate adjustment mechanism, a user may manually adjust the height and position of the legs 22 relative to the main housing 18. In some embodiments, when the user lifts up on the main housing 18, a handle mechanism (e.g., used to transport the area light and stand light), or the release mechanism, the legs 22 automatically expand into the extended position. Upon deployment of the release mechanism, the legs 22 will not deploy into a locked position until the head assembly 26 is moved away from the light shroud 46. For example, a user sets the light 10 on a support surface and depresses the automatic release mechanism. Then, the legs 22 will extend, and the user will have to manually slide the extension poles 30 to the desired position.

[0059] Fig. 12A-12C illustrate the head assembly 26 of the stand light 10. The head assembly 26 is supported on a second end 14b of the body opposite the main housing 18. The head assembly 26 includes a main light head 98, a support arm 102, a lens 106, and a light source 110. In the illustrated embodiment, the light source 110 includes a plurality of light emitting diodes 112 (LEDs) arranged in a grid. The light emitting diodes 112 are coupled to a heat sink 113 (Fig. 15) positioned within the light head 98. In other

embodiments, the light source 110 may include other suitable types of light sources, such as incandescent bulbs, halogen bulbs, and the like.

[0060] The light head 98 is semi-circularly shaped, such that the portion of the light head 98 including the lens 106 is substantially flat. Additionally, the lens 106 is substantially rectangular with beveled edges. However, in alternative embodiments, the light head 98 and the lens 106 may include other shapes (e.g., circular, square, etc.).

[0061] The support arm 102 is coupled to an end of the uppermost extension pole 30 opposite the light shroud 46. The support arm 102 surrounds and supports the light head 98 and forms a generally U-shaped bracket. In the illustrated embodiment, the support arm 102 surrounds the bottom and sides of the light head 98. However, in alternative embodiments, the support arm 102 may cover more or less of the light head 98.

[0062] The light head 98 is rotatable relative to the support arm 102 about a first axis 114 (which is generally horizontal when the light 10 is supported on a surface). The first axis 114 intersects the light head 98 where the support arm 102 couples to the light head 98. The light head 98 may rotate, for example, up to 180 degrees about the first axis 114. In other embodiments, the light head 98 may rotate through a larger or smaller range about the first axis 114. As shown in Fig. 15, the light head 98 includes two bosses 116 that are coaxial with the first axis 114 and coupled to the support arm 102 for rotation about the two bosses 116. A gasket 117 is positioned around each boss 116 between the bosses 116 and the support arm 102. The gaskets 117 create friction between the light head 98 and the support arm 102 to help maintain the light head 98 in any rotational position relative to the support arm 102 without requiring a positive locking engagement. In addition, a center of mass of the light head 98 (particularly the heat sink 113, the LEDs 112, and the lens 106) is designed to be on or near the first axis 114, reducing the moment about the first axis 114. In the illustrated embodiment, the gaskets 117 are O-rings. The gaskets 117 reduce the number of components (e.g., washers, springs, nuts, etc.) used to maintain the position of the light 98 compared to conventional light heads, which reduces the complexity and assembly time of the light 10. In other embodiments, the gaskets 117 may be other suitable members to create sufficient friction between the light head 98 and the support arm 102. In some embodiments, the head assembly 24 and/or the support arm 102 may include a series of detents that releasably hold the light head 98 in a finite number of positions.

[0063] Referring back to Figs. 12A-12C, the support arm 102 may also rotate relative to the uppermost extension pole 30 about a second axis 118 (which is generally vertical when the light 10 is supported on a surface). The second axis 118 is perpendicular to the first axis 114 and is collinear with a central longitudinal axis of the extension poles 30. In some embodiments, the light 10 may include a slip ring between the support arm 102 and the uppermost extension pole 30 to maintain an electrical connection to the light head 98 as the support arm 102 rotates relative to the extension pole 30. In such embodiments, the support arm 102 (and thereby the light head 98) may continuously rotate over 360 degrees relative to the extension pole 30. In other embodiments, rotation of the support arm 102 relative to the extension pole 30 may be limited to less than 360 degrees.

[0064] When in the collapsed position, the head assembly 26 is at least partially received in the light shroud 46. In this position, the support arm 102 is received in the cutouts 48 (Figs. 2B and 2D) of the light shroud 46. The support arm 102 and the cutouts 48 ensure the head assembly 26 is properly aligned when lowered into the light shroud 46. The light shroud 26 also inhibits the light assembly 26 from rotating about either axis 114, 118 while in the collapsed position. As shown in Fig. 13, the head assembly 26 also faces downward (e.g., toward the body 14 and the main housing 18) when received in the light shroud 46. That is, the lens 106 and the light source 110 face a bottom of the light shroud 46 to help further protect the lens 106 and the light source 110. In alternative embodiments, more or less of the light head assembly 26 may be received in the light shroud 46. For example, in some alternative embodiments, the light head assembly 26 may engage a top portion of the light shroud 46 rather than being received within the light shroud 46.

[0065] With continued reference to Fig. 13, the light shroud 46 further includes notches 122 formed on inner surfaces of sidewalls 126 of the light shroud 26 between the cutouts 48. The notches 122 are shaped and sized to receive portions of the support arm 102. Particularly, the notches 122 receive portions of the support arm 102 when the head assembly 26 is in a lowest resting position, as shown in Fig. 14. In this position, the extension poles 30 are almost fully retracted into the main center shaft 34, but the light head 98 is not received in the light shroud 46. Instead, the support arm 102 is rotated 90 degrees relative to the light shroud 46 so the light head 98 rests on top of the light shroud 46. The notches 122 provide a key-in feature that helps maintain the head assembly 26 in this position and inhibits the head assembly 26 from rotating relative to the light shroud 46.

[0066] As shown in Figs. 19 and 20, the light shroud 46 also includes a detent mechanism to releasably hold the light head 98 in the collapsed position. The illustrated detent mechanism includes two detent arms 300 positioned on opposite sides of the support arm 102. Each arm 300 includes an enlarged lip 304 that engages the support arm 102 when the light head 98 is fully received in the light shroud 46. A user can move the light head 98 out of the shroud 46 by lifting (e.g., pulling) the light head 98 with sufficient force to temporarily deflect the detent arms 300 away from the support arm 102. Conversely, a user can move the light head 98 into the shroud 46 by lowering (e.g., pushing) the light head 98 with sufficient force to temporarily deflect the detent arms 300 away from the support arm 102 until the support arm 102 clears the enlarged lips 304 and snaps into place.

[0067] Although the invention has been described in detail with reference to certain preferred embodiments, variations and modifications exist within the scope and spirit of one or more independent aspects of the invention as described. Various features and advantage of the invention are set forth in the following claims.

CLAIMS

What is claimed is:

1. A stand light comprising:
 - a telescoping body including a main center shaft, an extension pole extendable out of the main center shaft, and a sleeve movably supported on the main center shaft;
 - a head assembly supported by the extension pole, the head assembly including a light source; and
 - a plurality of legs pivotally coupled to the body, the plurality of legs movable with the sleeve from a collapsed position to an extended position, in which distal ends of the plurality of legs are moved away from the body;wherein a first of the plurality of legs includes a main portion and an aperture extending through the main portion to form a side portion, wherein a second of the plurality of legs includes a main portion and an aperture extending through the main portion to form a side portion, and wherein when the plurality of legs is in the collapsed position, the side portion of the first of the plurality of legs and the side portion of the second of the plurality of legs come together to form a handle configured to be grasped by a user.
2. The stand light of claim 1, wherein each of the plurality of legs includes a main portion and an aperture extending through the main portion to form a side portion, and wherein when the plurality of legs is in the collapsed position, the side portions of adjacent legs come together to form handles configured to be grasped by a user.
3. The stand light of claim 1, wherein the first of the plurality of legs includes a second aperture extending through the main portion to form a second side portion, and wherein the second of the plurality of legs includes a second aperture extending through the main portion to form a second side portion.
4. The stand light of claim 1, further comprising a plurality of leg links extending between the plurality of legs and the body.

5. The stand light of claim 4, wherein each leg includes a projection formed on an inner surface of the leg, and wherein the projection inhibits the corresponding leg link from decoupling from the leg.
6. The stand light of claim 1, further comprising a main housing coupled to an end of the body opposite from the head assembly, wherein the main housing includes a power port.
7. The stand light of claim 6, wherein at least one of the plurality of legs includes a recess formed in a distal end of the at least one of the plurality of legs, and wherein the recess provides clearance for an extension cord connected to the power port.
8. The stand light of claim 1, further comprising:
 - a main housing coupled to an end of the body opposite from the head assembly, the main housing including a battery receptacle; and
 - a battery pack removably coupled to the battery receptacle.
9. The stand light of claim 1, wherein the body also includes a light shroud coupled to an end of the main center shaft, and wherein the light shroud at least partially receives the head assembly when the extension pole is retracted into the main center shaft.
10. The stand light of claim 9, wherein the head assembly includes a support arm and a light head pivotably coupled to the support arm, wherein the light shroud includes cutouts formed in opposite sides of the light shroud, and wherein the cutouts receive the support arm when the extension pole is retracted into the main center shaft.
11. The stand light of claim 10, wherein the light shroud also includes notches formed on inner surfaces of sidewalls between the cutouts, and wherein the notches receive portions of the support arm when the head assembly is in a lowest resting position, in which the light head rests on top of the light shroud.
12. The stand light of claim 10, wherein the light shroud further includes a detent mechanism to releasably hold the support arm when the extension pole is retracted into the main center shaft.

13. The stand light of claim 1, wherein the sleeve includes an actuator operable to lock the sleeve relative to the main center shaft in a first position, where the plurality of legs is in the collapsed position, and in a second position, where the plurality of legs is in the extended position.

14. The stand light of claim 13, wherein the actuator is a first actuator, wherein the sleeve includes a second actuator positioned on an opposite side of the sleeve from the first actuator, and wherein the first and second actuators are configured to be actuated at the same time by a single hand of a user.

15. The stand light of claim 1, wherein the body also includes a detent mechanism having a first detent member coupled to an upper end of the main center shaft and a second detent member coupled to a lower end of the extension pole, and wherein the first detent member engages the second detent member to releasably secure the extension pole in a maximum extended position.

16. The stand light of claim 15, wherein the extension pole is maintained at any height between a collapsed position and the maximum extended position by friction between the second detent member and the main center shaft.

17. A stand light comprising:

a telescoping body including a main center shaft, an extension pole extendable out of the main center shaft, and a sleeve movably supported on the main center shaft;

a head assembly supported by the extension pole, the head assembly including a support arm, a light head coupled to the support arm, and a light source coupled to the light head;

a plurality of legs pivotally coupled to the body, the plurality of legs movable with the sleeve from a collapsed position to an extended position, in which distal ends of the plurality of legs are moved away from the body; and

a light shroud coupled to an end of the main center shaft, the light shroud including notches formed on inner surfaces of sidewalls of the light shroud, the notches receiving

portions of the support arm when the head assembly is in a lowest resting position, in which the light head rests on top of the light shroud.

18. The stand light of claim 17, wherein the light head is rotatable relative to the support arm about a first axis.

19. The stand light of claim 18, wherein the light head includes a boss coupled to the support arm and a gasket positioned between the boss and the support arm, and wherein the gasket maintains the light head in any rotational position relative to the support arm.

20. The stand light of claim 18, wherein the support arm is rotatable relative to the extension pole about a second axis that is perpendicular to the first axis.

21. The stand light of claim 17, wherein the light shroud at least partially receives the head assembly when the extension pole is retracted into the main center shaft, wherein the light shroud includes cutouts formed in opposite sides of the light shroud between the sidewalls, and wherein the cutouts receive the support arm when the extension pole is retracted into the main center shaft

22. The stand light of claim 21, wherein the light source faces downward when the head assembly is received in the light shroud.

23. The stand light of claim 21, wherein the light shroud includes a detent mechanism having a detent arm that engages the support arm when the head assembly is received in the light shroud.

24. A stand light comprising:
a telescoping body including a main center shaft, an extension pole extendable out of the main center shaft, and a sleeve movably supported on the main center shaft;
a head assembly supported by the extension pole, the head assembly including a light source; and

a plurality of legs pivotally coupled to the body, the plurality of legs movable with the sleeve from a collapsed position to an extended position, in which distal ends of the plurality of legs are moved away from the body;

wherein the body also includes a detent mechanism having a first detent member coupled to an upper end of the main center shaft and a second detent member coupled to a lower end of the extension pole, and wherein the first detent member engages the second detent member to releasably secure the extension pole in a maximum extended position.

25. The stand light of claim 24, wherein the extension pole is maintained at any height between a collapsed position and the maximum extended position by friction between the second detent member and the main center shaft.

26. The stand light of claim 24, wherein the extension pole is a first extension pole, and further comprising a second extension pole extendable out of the first extension pole, wherein the detent mechanism also has a third detent member coupled to an upper end of the first extension pole and a fourth detent member coupled to a lower end of the second extension pole, and wherein the third detent member engages the fourth detent member to releasably secure the second extension pole in a maximum extended position.

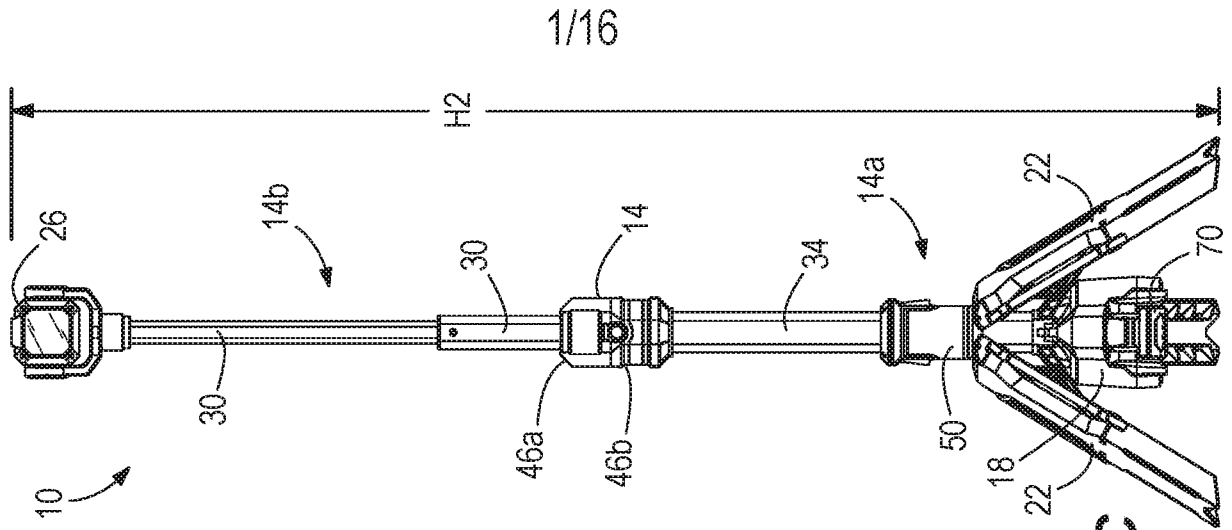

FIG. 1A

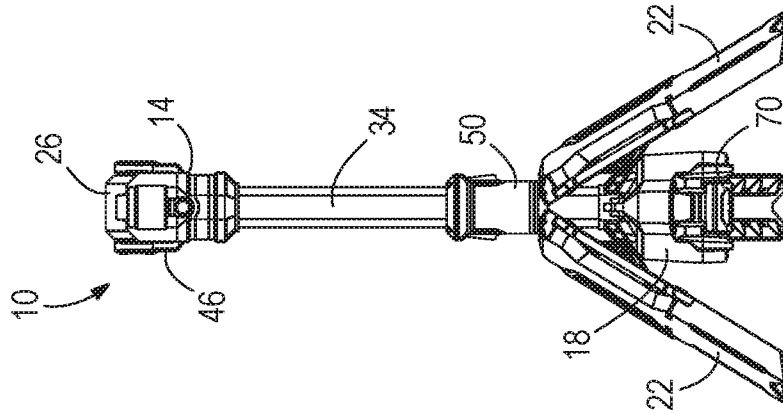

FIG. 1B

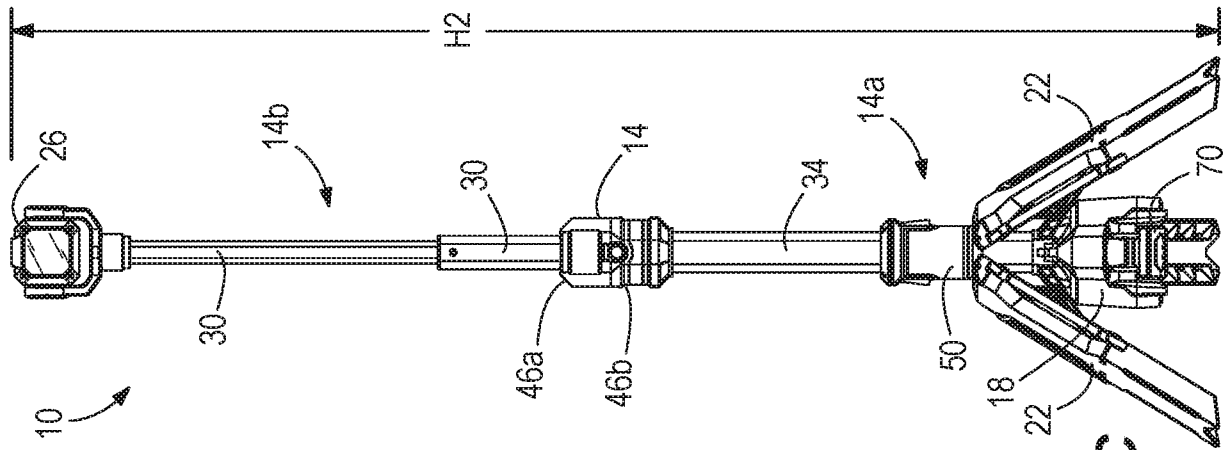

FIG. 1C

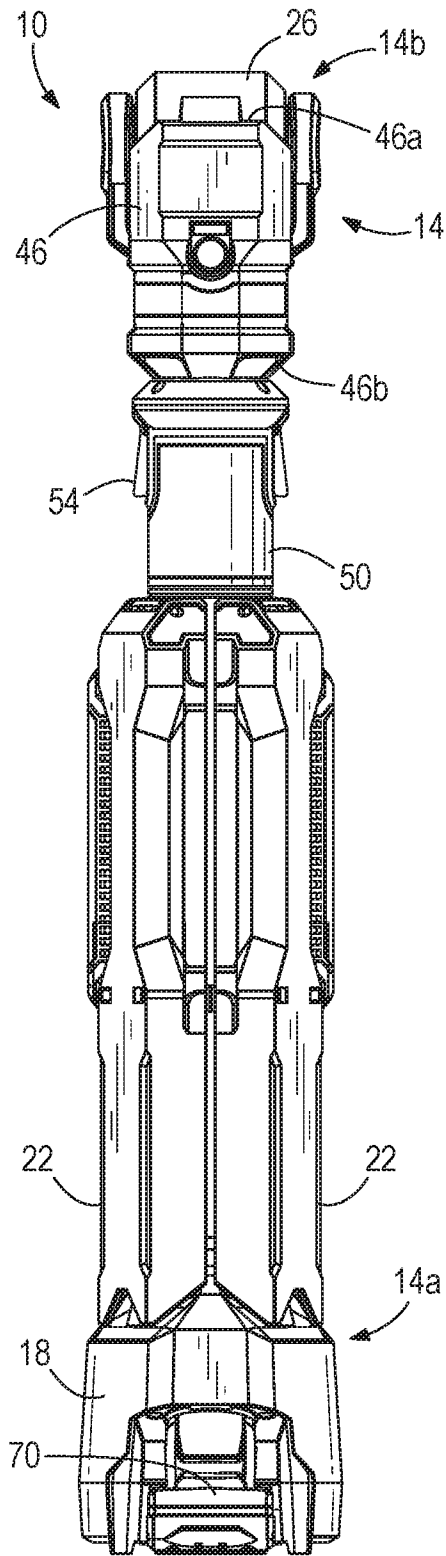

FIG. 2A

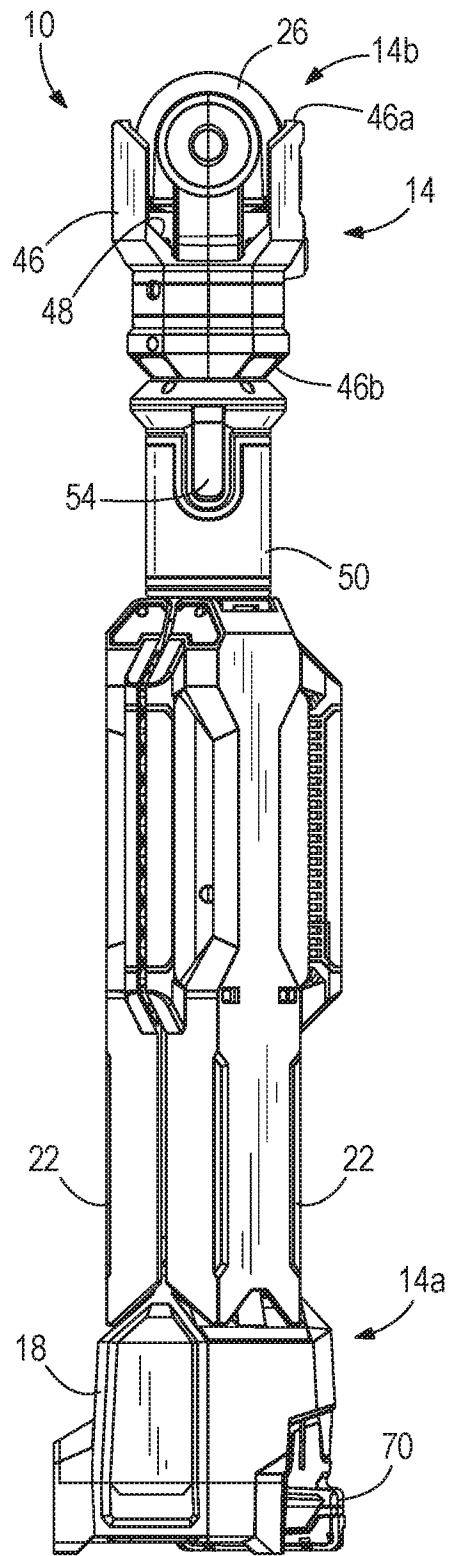

FIG. 2B

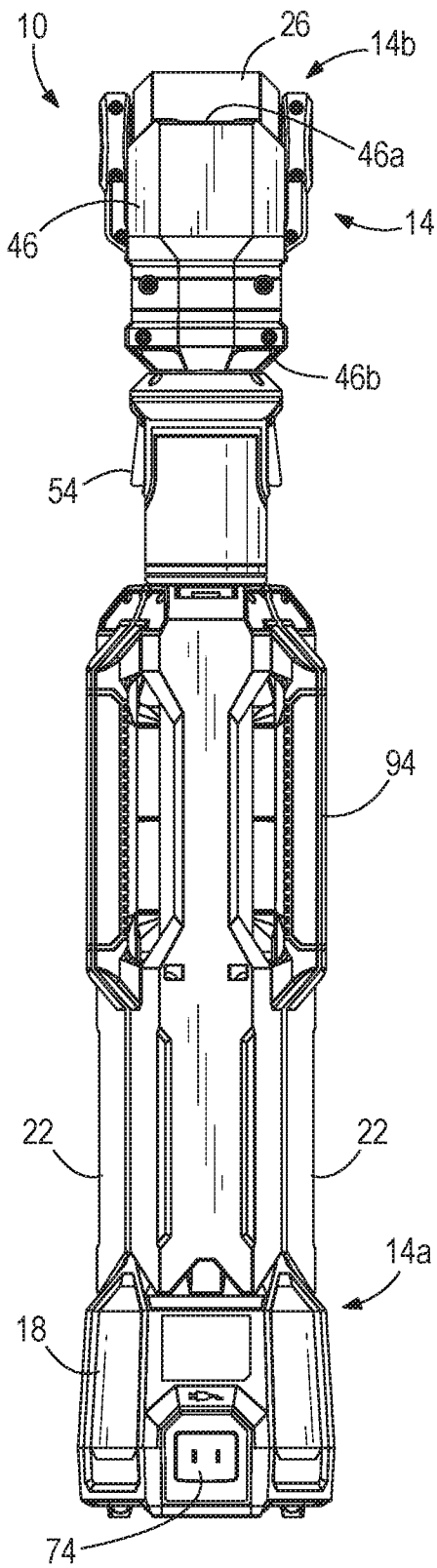

FIG. 2C

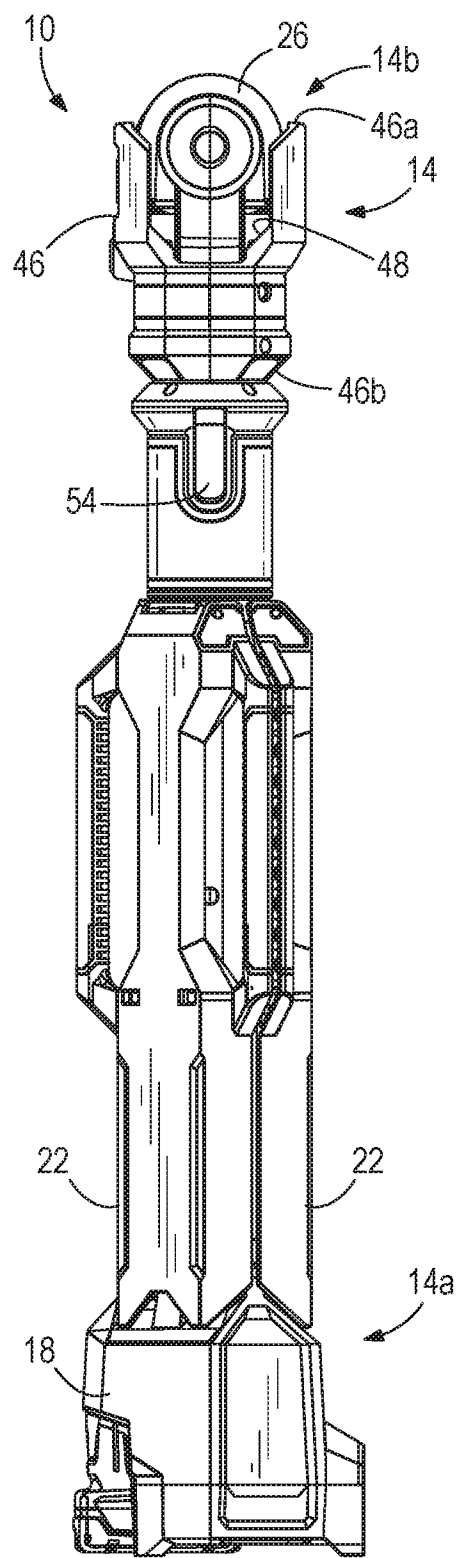
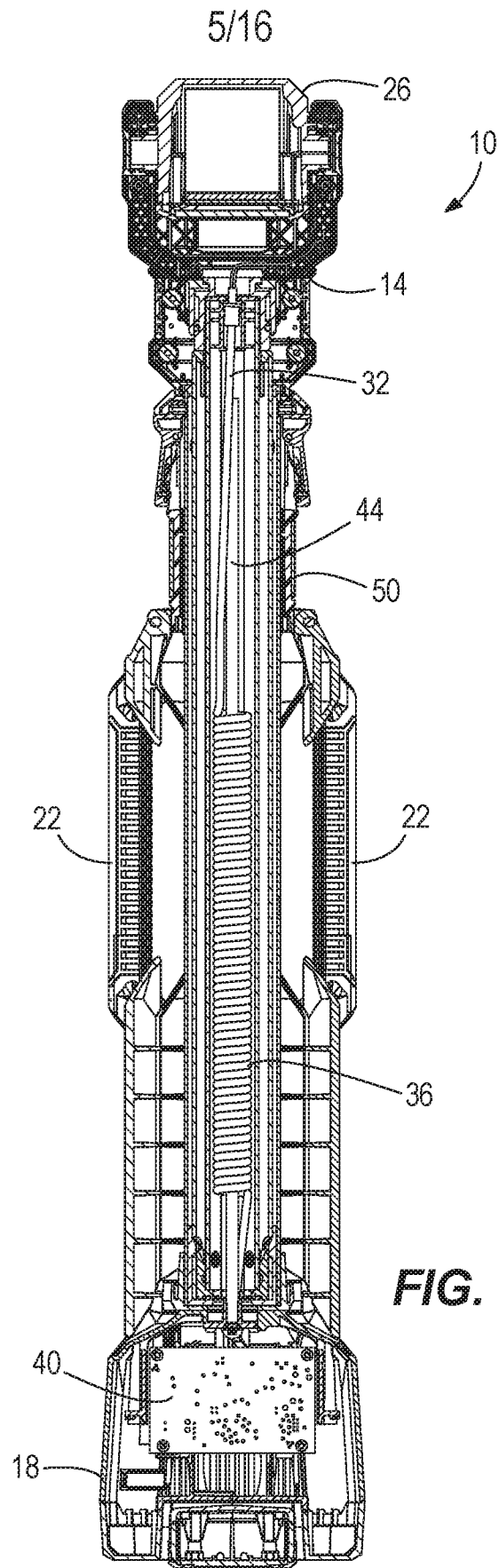

FIG. 2D



6/16

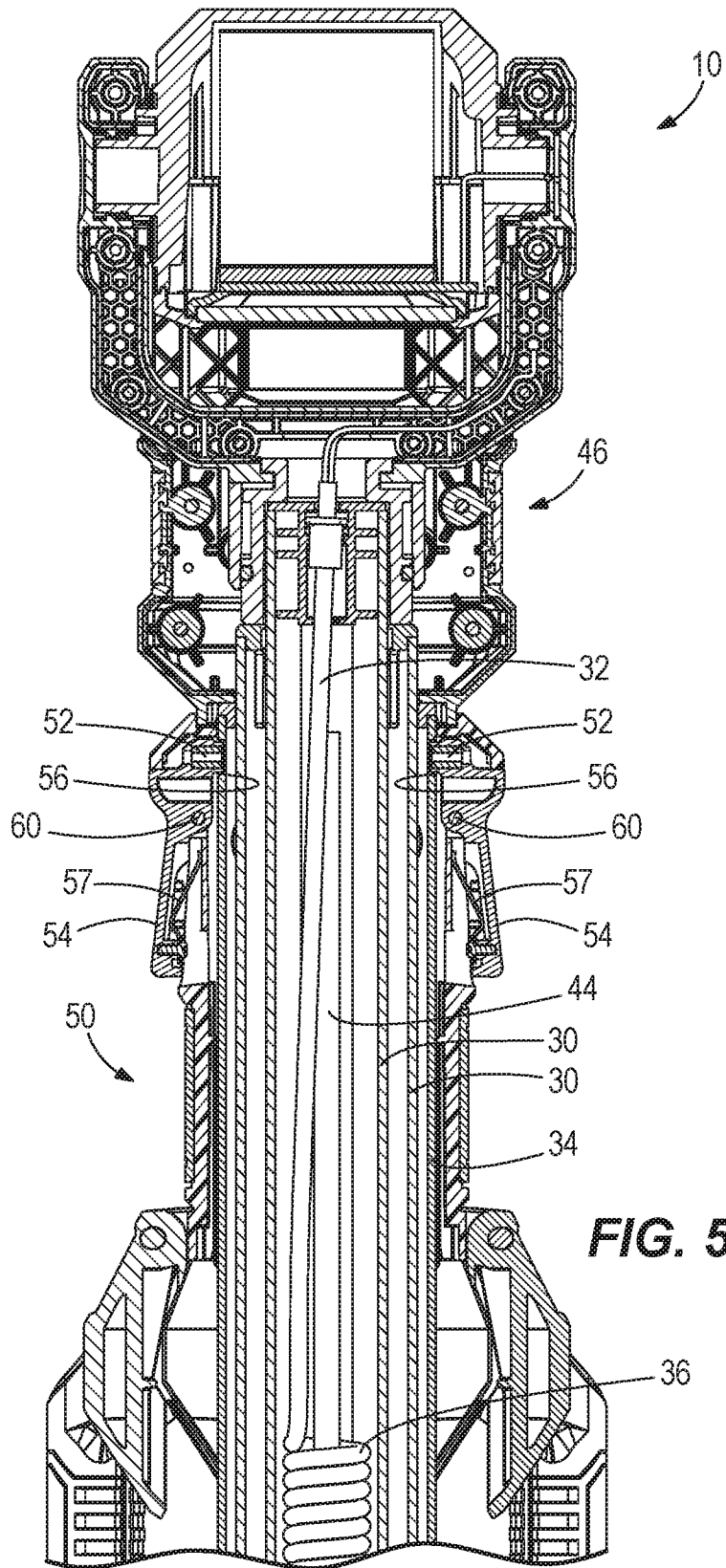

FIG. 5

7/16

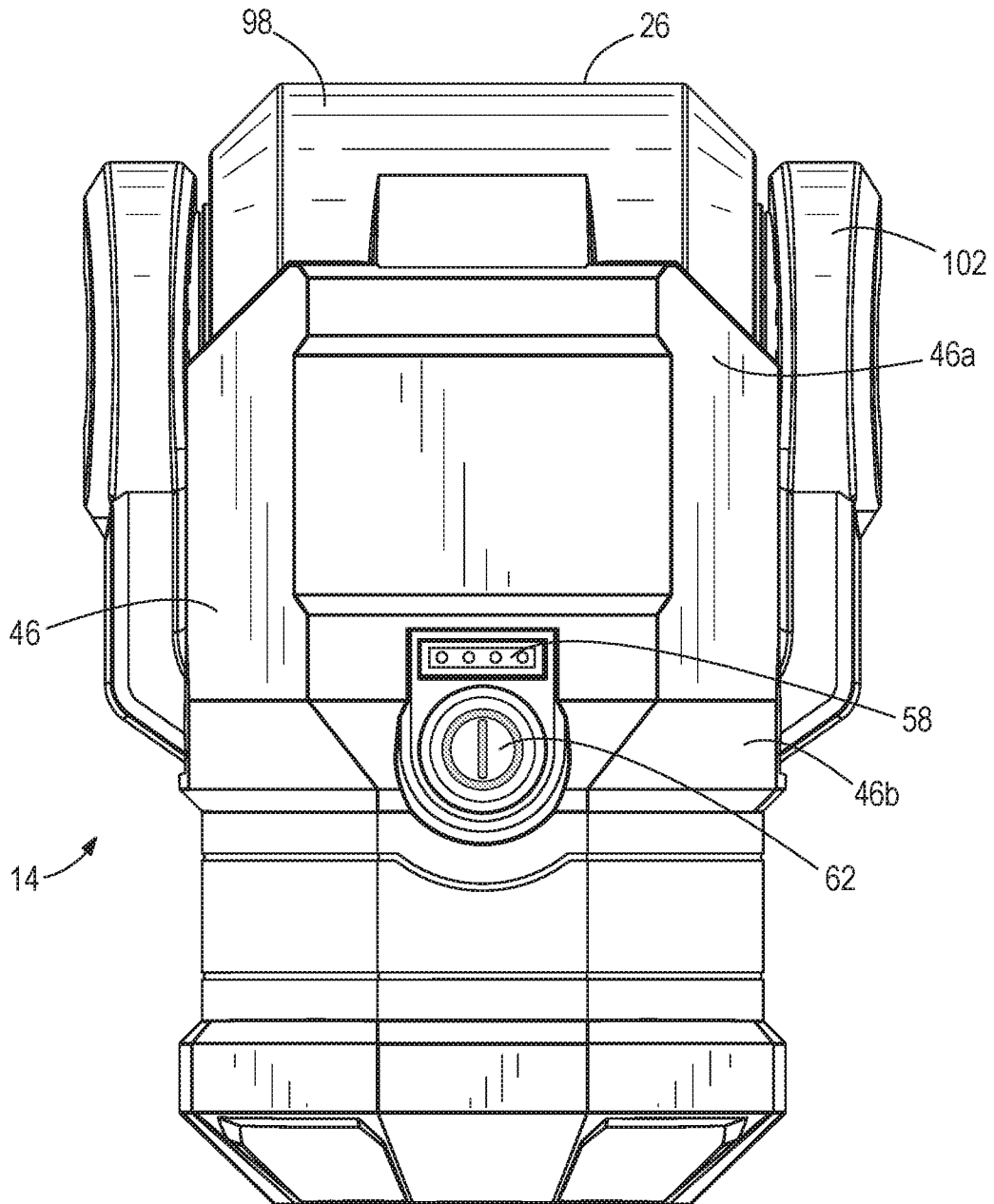

FIG. 6

8/16

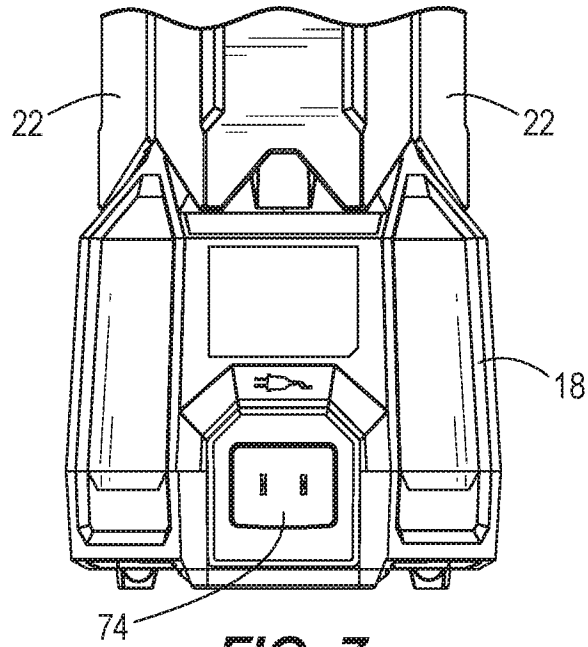

FIG. 7

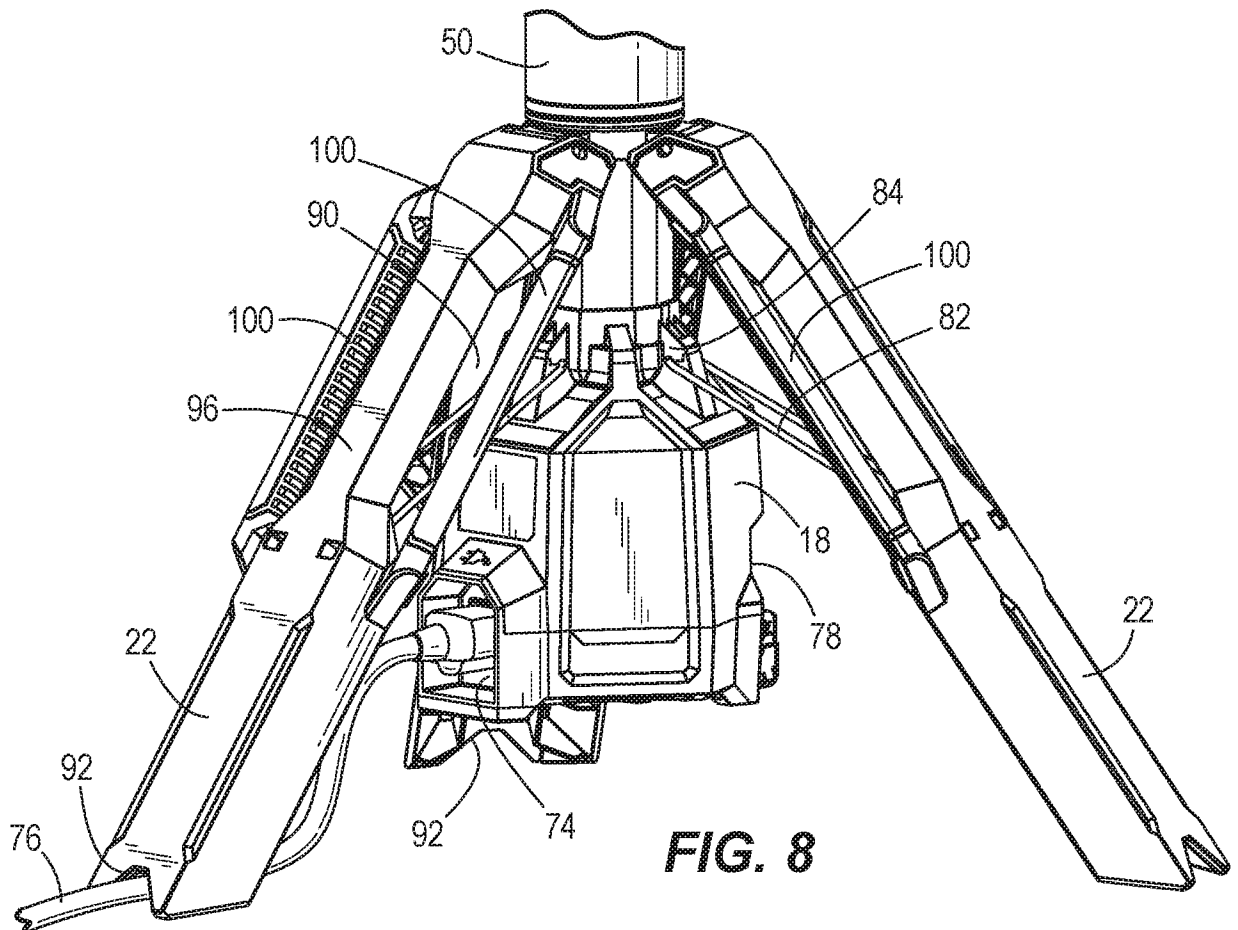

FIG. 8

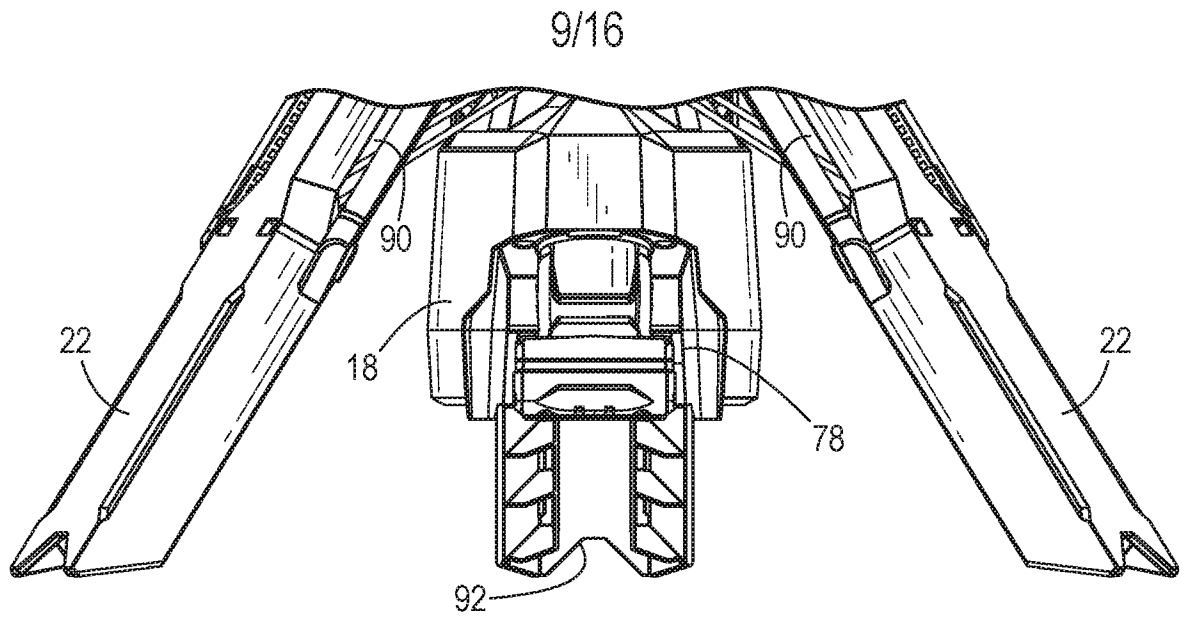

FIG. 9

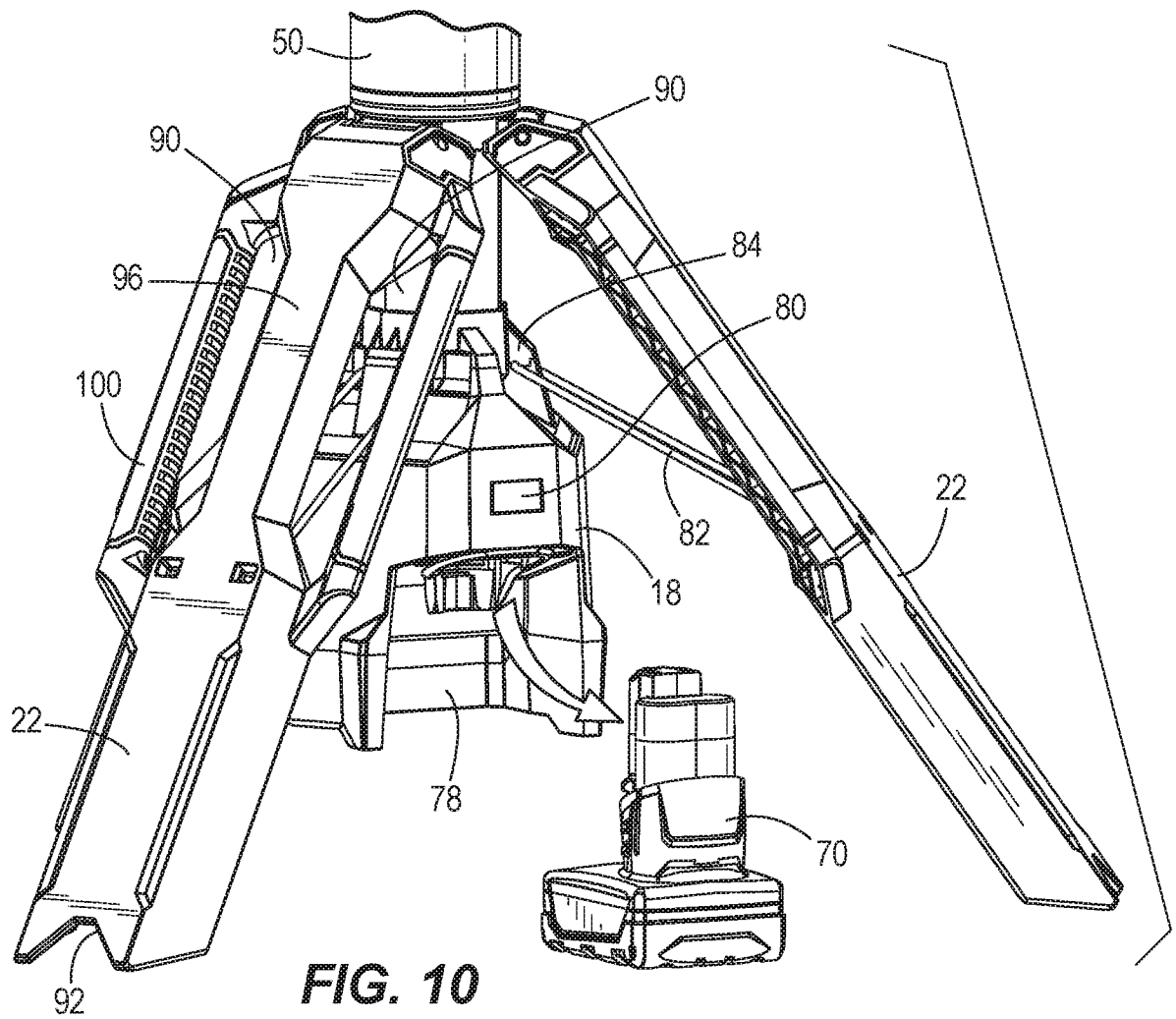

FIG. 10

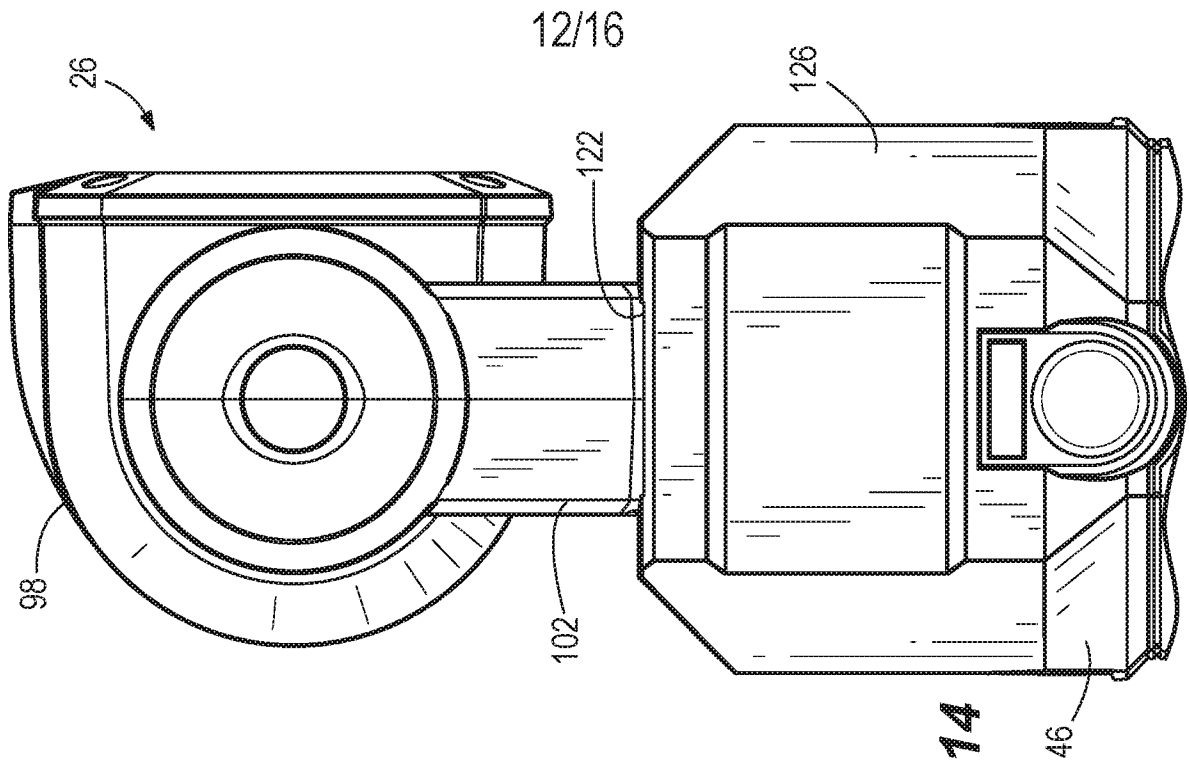

FIG. 14

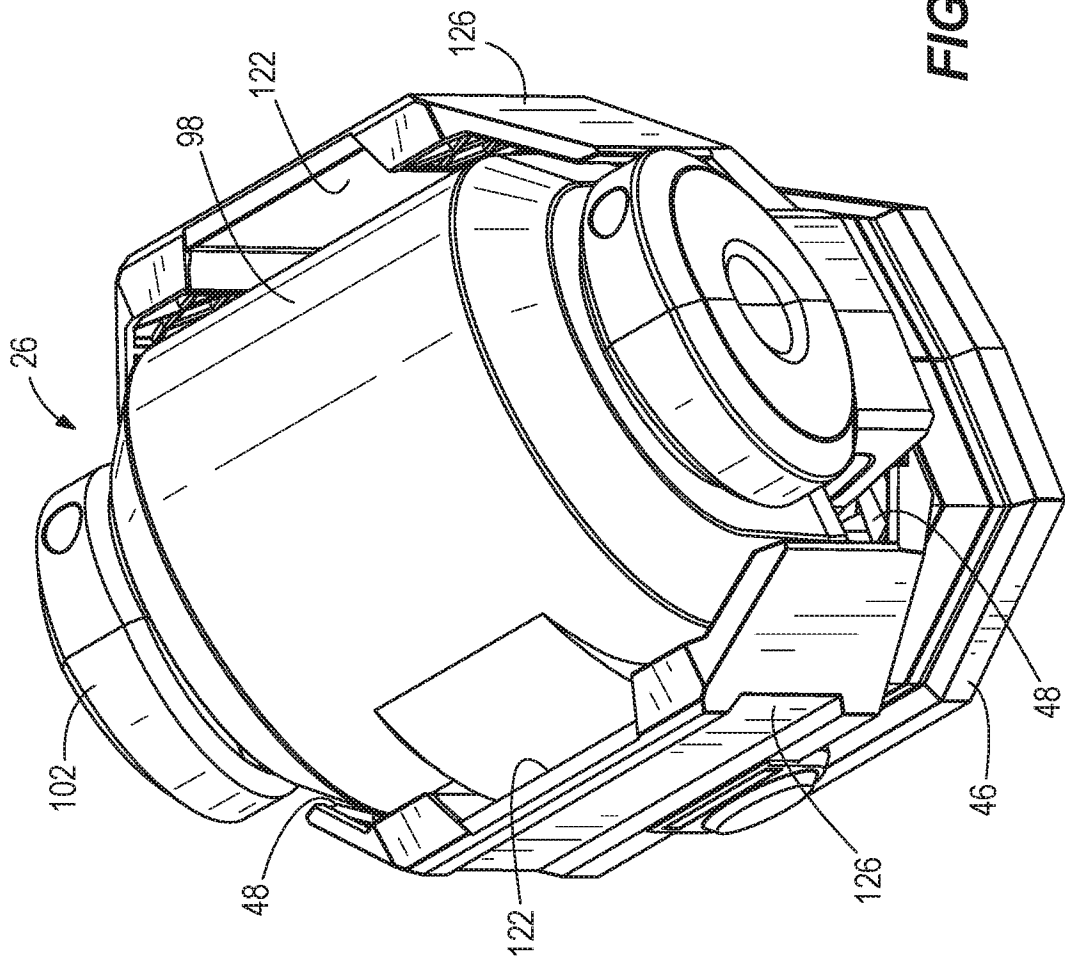

FIG. 13

13/16

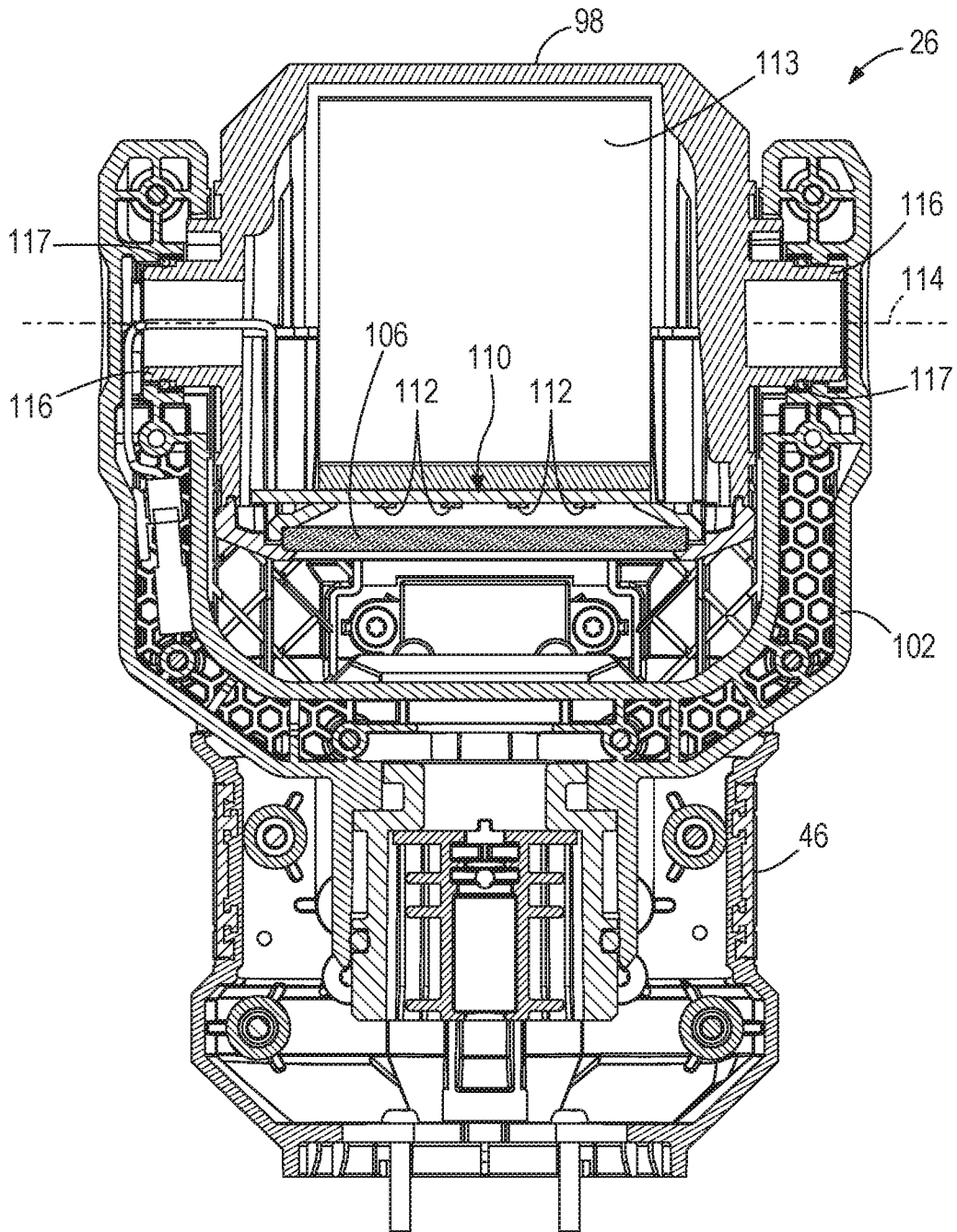

FIG. 15

14/16

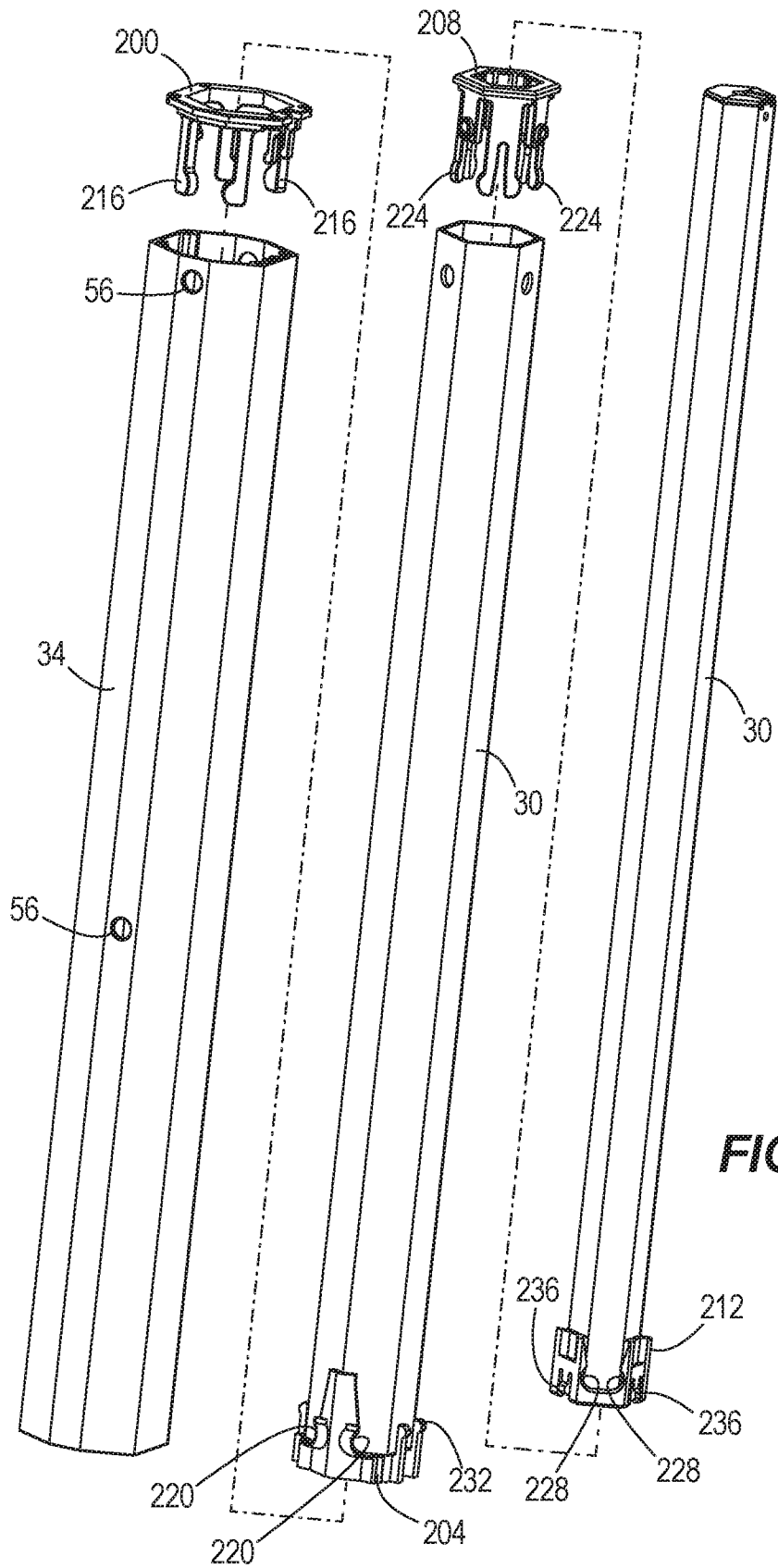

FIG. 16

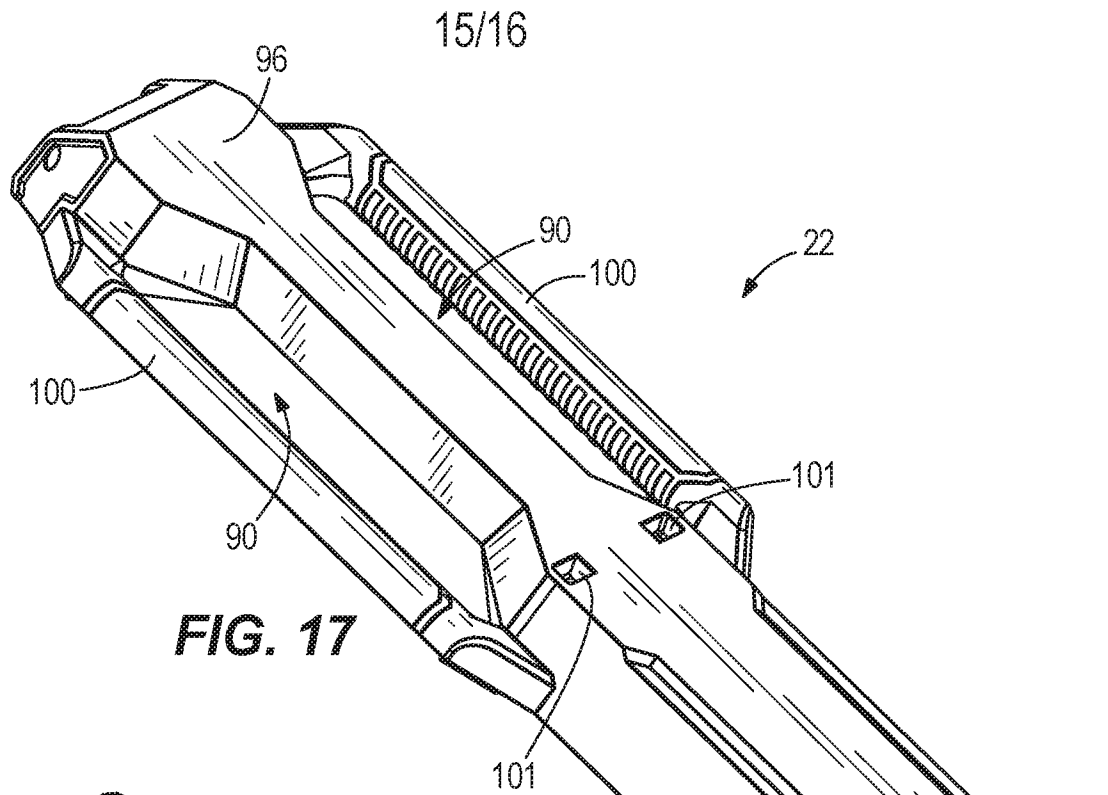

FIG. 17

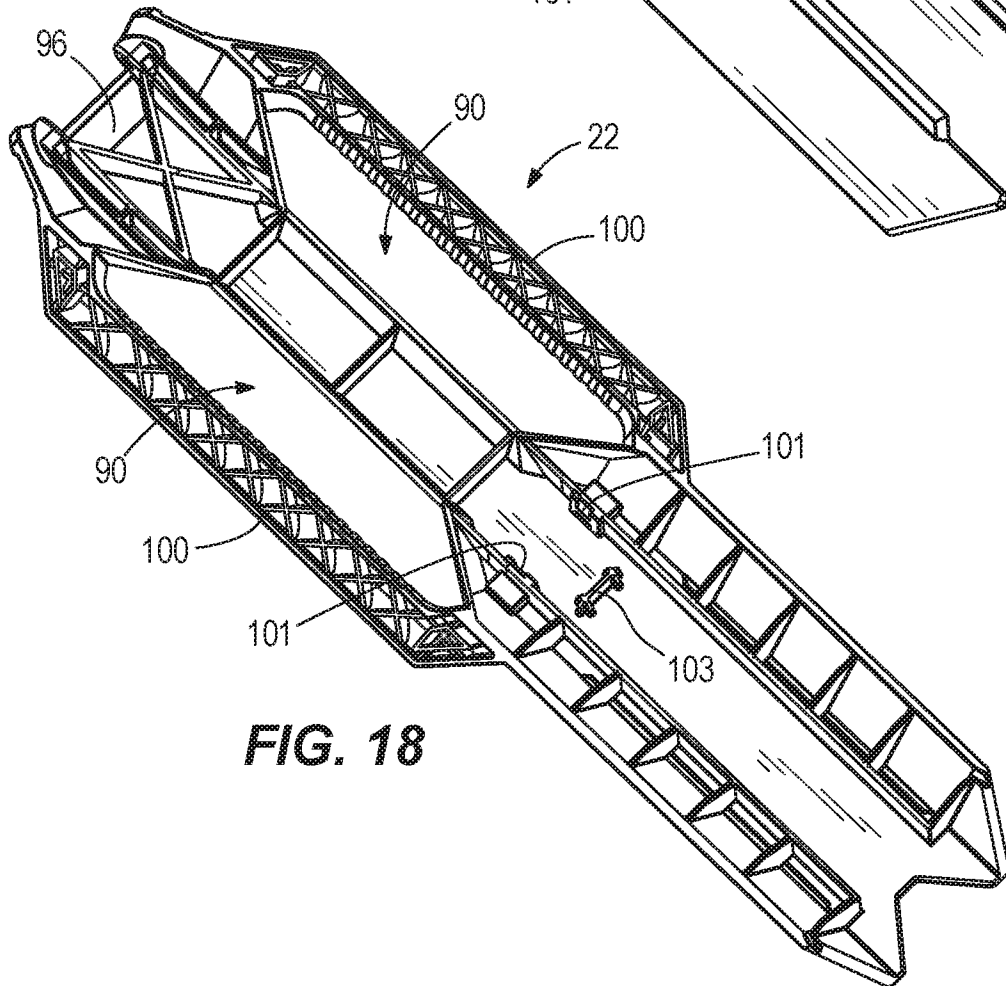

FIG. 18

16/16

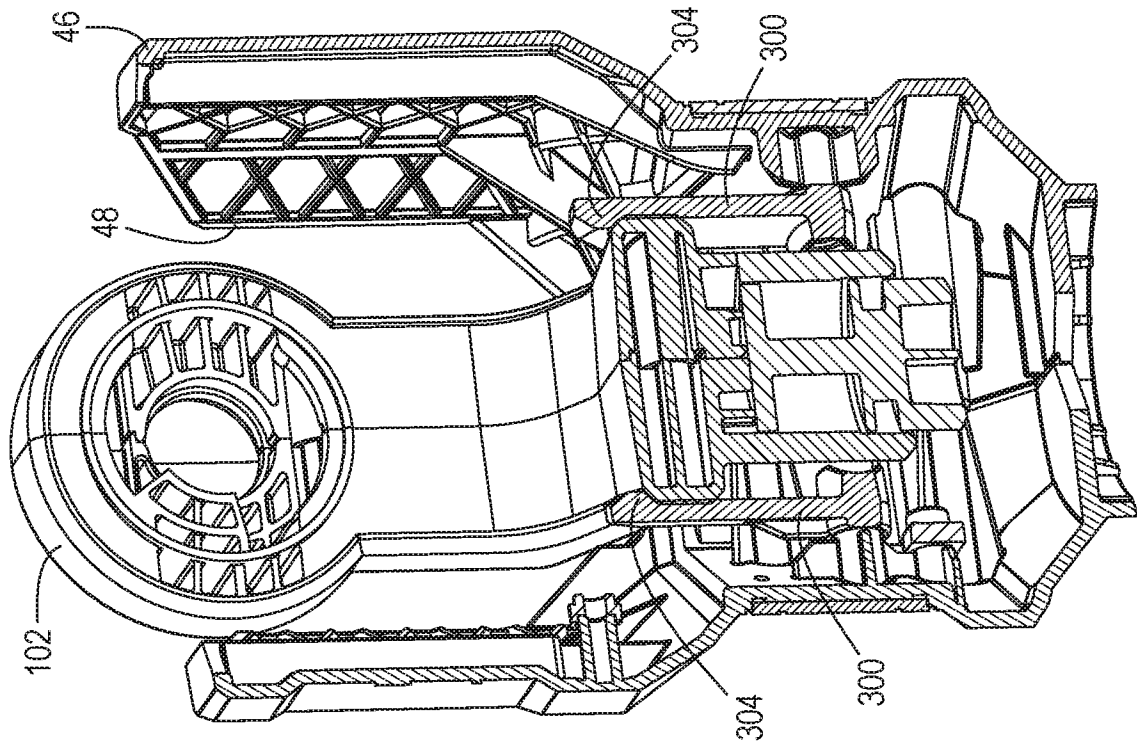

FIG. 20

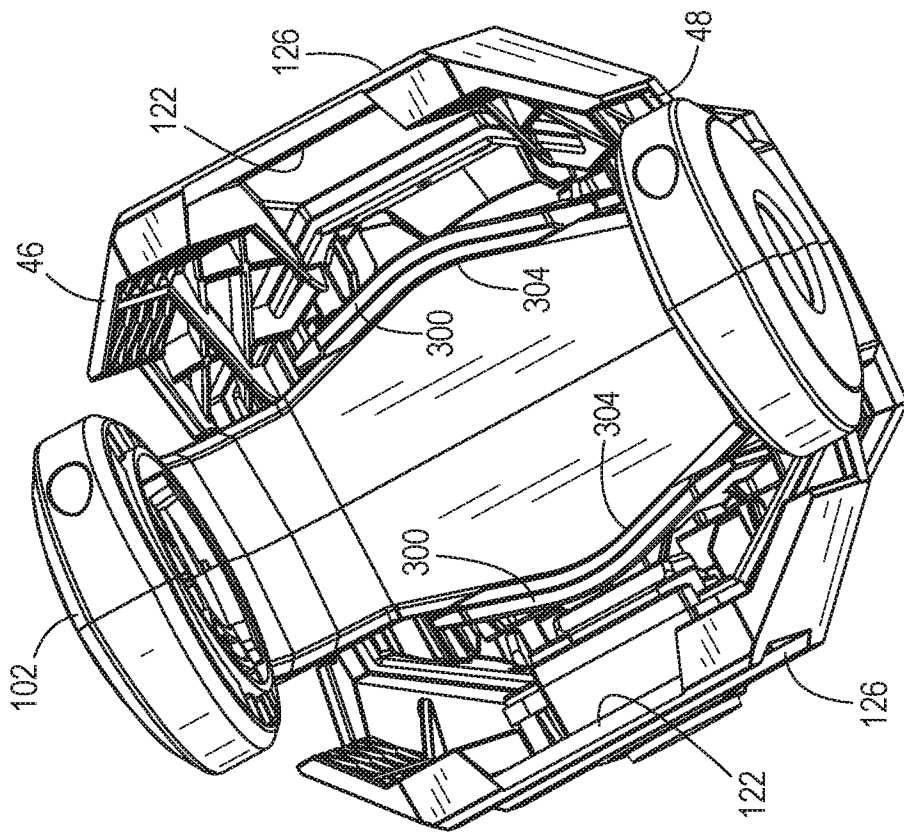

FIG. 19

INTERNATIONAL SEARCH REPORT

International application No.
PCT/US2018/054658**A. CLASSIFICATION OF SUBJECT MATTER****F21V 21/06(2006.01)i, F21V 21/22(2006.01)i, F21V 21/26(2006.01)i**

According to International Patent Classification (IPC) or to both national classification and IPC

B. FIELDS SEARCHED

Minimum documentation searched (classification system followed by classification symbols)

F21V 21/06; F16M 11/28; F16M 11/38; F21L 4/04; F21S 6/00; F21S 9/02; F21V 21/22; F21V 21/26

Documentation searched other than minimum documentation to the extent that such documents are included in the fields searched

Korean utility models and applications for utility models

Japanese utility models and applications for utility models

Electronic data base consulted during the international search (name of data base and, where practicable, search terms used)

eKOMPASS(KIPO internal) & keywords: light, leg, head, stand, pivot, collapse, shroud, detent, handle

C. DOCUMENTS CONSIDERED TO BE RELEVANT

Category*	Citation of document, with indication, where appropriate, of the relevant passages	Relevant to claim No.
X	US 2016-0312967 A1 (MILWAUKEE ELECTRIC TOOL CORPORATION) 27 October 2016 See paragraphs 30-49, claim 1, and figures 1-6, 8, 10, 14.	17-26
Y		1-16
Y	US 2016-0298831 A1 (NINGBO UTEC ELECTRIC CO. LTD.) 13 October 2016 See paragraph 39, and figure 2.	1-16
A	WO 2015-080767 A1 (MATTHEW INSKEEP) 04 June 2015 See paragraphs 30-42, and figures 1-5.	1-26
A	JP 2011-108647 A (PELICAN PRODUCTS INC.) 02 June 2011 See paragraphs 5-10, and figure 3.	1-26
A	US 2015-0192243 A1 (STREAMLIGHT, INC.) 09 July 2015 See paragraphs 40-44, and figures 2D-2F.	1-26

 Further documents are listed in the continuation of Box C. See patent family annex.

* Special categories of cited documents:

"A" document defining the general state of the art which is not considered to be of particular relevance

"E" earlier application or patent but published on or after the international filing date

"L" document which may throw doubts on priority claim(s) or which is cited to establish the publication date of another citation or other special reason (as specified)

"O" document referring to an oral disclosure, use, exhibition or other means

"P" document published prior to the international filing date but later than the priority date claimed

"T" later document published after the international filing date or priority date and not in conflict with the application but cited to understand the principle or theory underlying the invention

"X" document of particular relevance; the claimed invention cannot be considered novel or cannot be considered to involve an inventive step when the document is taken alone

"Y" document of particular relevance; the claimed invention cannot be considered to involve an inventive step when the document is combined with one or more other such documents, such combination being obvious to a person skilled in the art

"&" document member of the same patent family

Date of the actual completion of the international search

29 January 2019 (29.01.2019)

Date of mailing of the international search report

29 January 2019 (29.01.2019)

Name and mailing address of the ISA/KR

International Application Division

Korean Intellectual Property Office

189 Cheongsa-ro, Seo-gu, Daejeon, 35208, Republic of Korea

Facsimile No. +82-42-481-8578

Authorized officer

PARK, Hye Lyun

Telephone No. +82-42-481-3463

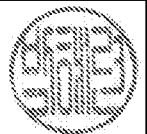

INTERNATIONAL SEARCH REPORT

Information on patent family members

International application No.

PCT/US2018/054658

Patent document cited in search report	Publication date	Patent family member(s)	Publication date
US 2016-0312967 A1	27/10/2016	CN 205782178 U US 2017-0350577 A1	07/12/2016 07/12/2017
US 2016-0298831 A1	13/10/2016	US 9810408 B2	07/11/2017
WO 2015-080767 A1	04/06/2015	US 2014-0301066 A1 US 9222633 B2	09/10/2014 29/12/2015
JP 2011-108647 A	02/06/2011	AU 2010-246335 A1 AU 2010-246335 B2 CA 2719151 A1 CA 2719151 C CN 102072411 A CN 102072411 B CN 104132255 A CN 104132255 B EP 2325552 A1 EP 2325552 B1 ES 2632176 T3 JP 5707104 B2 US 2011-0122605 A1 US 2012-0261530 A1 US 2014-0192543 A1 US 8201979 B2 US 8651438 B2 US 9303853 B2	09/06/2011 26/07/2012 20/05/2011 21/10/2014 25/05/2011 20/08/2014 05/11/2014 06/06/2017 25/05/2011 05/04/2017 11/09/2017 22/04/2015 26/05/2011 18/10/2012 10/07/2014 19/06/2012 18/02/2014 05/04/2016
US 2015-0192243 A1	09/07/2015	CA 2933894 A1 CL 2016001757 A1 EP 3092435 A1 EP 3092435 A4 EP 3092435 B1 PL 3092435 T3 US 2018-0051848 A1 US 9816661 B2 WO 2015-105983 A1	16/07/2015 23/12/2016 16/11/2016 23/08/2017 01/08/2018 30/11/2018 22/02/2018 14/11/2017 16/07/2015