

(19) World Intellectual Property Organization
International Bureau



(43) International Publication Date
23 May 2002 (23.05.2002)

PCT

(10) International Publication Number
WO 02/40769 A2

- (51) International Patent Classification⁷: D21F Village Drive, Neenah, WI 54956-5121 (US). **LIN, Philip, Sim**; 2543 Village Lane, Oshkosh, WI 54904 (US). **LARSON, Kenneth, Curtis**; 1500 S. Weimar Street, Appleton, WI 54915 (US).
- (21) International Application Number: PCT/US01/46263
- (22) International Filing Date: 1 November 2001 (01.11.2001) (74) Agents: **PUGLIESE, Sebastian, C., III** et al.; Kimberly-Clark Worldwide, Inc., 401 N. Lake Street, Neenah, WI 54956 (US).
- (25) Filing Language: English
- (26) Publication Language: English (81) Designated States (*national*): AE, AG, AL, AM, AT, AU, AZ, BA, BB, BG, BR, BY, BZ, CA, CH, CN, CO, CR, CU, CZ, DE, DK, DM, DZ, EC, EE, ES, FI, GB, GD, GE, GH, GM, HR, HU, ID, IL, IN, IS, JP, KE, KG, KP, KR, KZ, LC, LK, LR, LS, LT, LU, LV, MA, MD, MG, MK, MN, MW, MX, MZ, NO, NZ, OM, PH, PL, PT, RO, RU, SD, SE, SG, SI, SK, SL, TJ, TM, TR, TT, TZ, UA, UG, UZ, VN, YU, ZA, ZW.
- (30) Priority Data: 09/706,149 3 November 2000 (03.11.2000) US
- (71) Applicant: **KIMBERLY-CLARK WORLDWIDE, INC.** [US/US]; 401 N. Lake Street, Neenah, WI 54956 (US).
- (72) Inventors: **LINDSAY, Jeffrey, Dean**; 20 Diane Lane, Appleton, WI 54915 (US). **BURAZIN, Mark, Alan**; 35 East County Road Y, Apt 3, Oshkosh, WI 54901 (US). **CHEN, Fung-Jou**; 3216 White Birch Lane, Appleton, WI 54915 (US). **HERMANS, Michael, Alan**; 1154 Park
- (84) Designated States (*regional*): ARIPO patent (GH, GM, KE, LS, MW, MZ, SD, SL, SZ, TZ, UG, ZW), Eurasian patent (AM, AZ, BY, KG, KZ, MD, RU, TJ, TM), European patent (AT, BE, CH, CY, DE, DK, ES, FI, FR, GB, GR, IE, IT, LU, MC, NL, PT, SE, TR), OAPI patent (BF, BJ, CF,

[Continued on next page]

(54) Title: THREE-DIMENSIONAL TISSUE AND METHODS FOR MAKING THE SAME

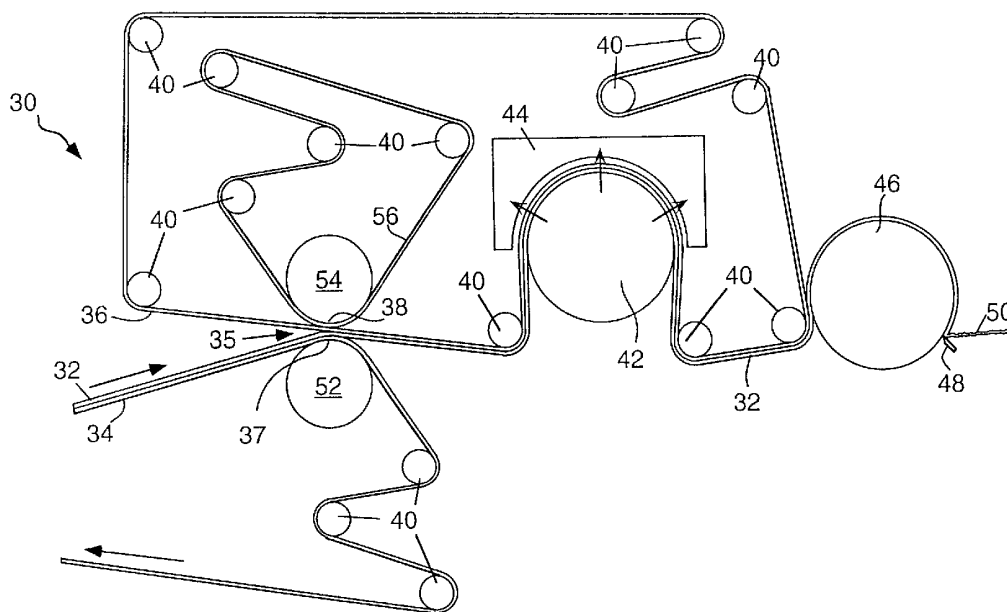

(57) Abstract: An improved method for imprinting a paper web during a wet pressing event is disclosed which results in asymmetrical protrusions corresponding to the deflection conduits of a deflection member. In one embodiment, differential velocity transfer during a pressing event serves to improve the molding and imprinting of a web with a deflection member. Improved deflection members are also disclosed. Improved tissue webs produced are also disclosed having useful sets of physical and geometrical properties, such as a pattern densified network and a repeating pattern of protrusions having asymmetrical structures.



WO 02/40769 A2



CG, CI, CM, GA, GN, GQ, GW, ML, MR, NE, SN, TD, TG).

KG, KZ, MD, RU, TJ, TM), European patent (AT, BE, CH, CY, DE, DK, ES, FI, FR, GB, GR, IE, IT, LU, MC, NL, PT, SE, TR), OAPI patent (BF, BJ, CF, CG, CI, CM, GA, GN, GQ, GW, ML, MR, NE, SN, TD, TG)

Declarations under Rule 4.17:

— as to applicant's entitlement to apply for and be granted a patent (Rule 4.17(ii)) for the following designations AE, AG, AL, AM, AT, AU, AZ, BA, BB, BG, BR, BY, BZ, CA, CH, CN, CO, CR, CU, CZ, DE, DK, DM, DZ, EC, EE, ES, FI, GB, GD, GE, GH, GM, HR, HU, ID, IL, IN, IS, JP, KE, KG, KP, KR, KZ, LC, LK, LR, LS, LT, LU, LV, MA, MD, MG, MK, MN, MW, MX, MZ, NO, NZ, OM, PH, PL, PT, RO, RU, SD, SE, SG, SI, SK, SL, TJ, TM, TR, TT, TZ, UA, UG, UZ, VN, YU, ZA, ZW, ARIPO patent (GH, GM, KE, LS, MW, MZ, SD, SL, SZ, TZ, UG, ZW), Eurasian patent (AM, AZ, BY,

— as to the applicant's entitlement to claim the priority of the earlier application (Rule 4.17(iii)) for all designations

Published:

— without international search report and to be republished upon receipt of that report

For two-letter codes and other abbreviations, refer to the "Guidance Notes on Codes and Abbreviations" appearing at the beginning of each regular issue of the PCT Gazette.

THREE-DIMENSIONAL TISSUE AND METHODS FOR MAKING THE SAME

Background of the Invention

In the art of tissue making, a deflection member may be used to imprint a tissue web against a Yankee dryer or other drying surface. Known deflection members include macroscopically monoplanar fabrics such as a through-drying fabric having a woven substrate and UV-cured resin elements above the substrate. The cured resin elements define deflection conduits into which a moist tissue web can be deflected during a through drying operation to create bulky domes offering softness and absorbency, while the portions of the web residing on the surface of the resin elements are pressed against the dryer surface to create a network of pattern densified areas offering strength.

In the scope of imprinting technology, it is also known to use a press nip for increased deformation of the web into an imprinting fabric, as disclosed by Ampulski et al. in US Pat. No. 5,855,739, "Pressed Paper Web and Method of Making the Same," issued Jan. 5, 1999, and US Pat. No. 5,897,745, "Method of Wet Pressing Tissue Paper," issued April 27, 1999, both of which are herein incorporated by reference in a manner consistent herewith. A related concept is the use of a low permeability flexible film or web placed over a paper web as it resides on an imprinting or molding fabric, wherein the film helps in molding of the paper web when differential air pressure is applied, for the film reduces air flow through the web and increases the pressure differential experienced by the web, as disclosed in US Pat. No. 5,893,965, "Method of Making Paper Web Using Flexible Sheet of Material," issued to P.D. Trokhan and V. Vitenberg, April 13, 1999, herein incorporated by reference in a manner consistent herewith. The flexible film or web has the potential to increase water removal from the web as well as increase the degree of molding against a textured fabric. It is likewise said that a compression nip in which moist tissue is pressed between an imprinting fabric and a press felt can cause enhanced deformation and molding of a tissue web. This technology is said to allow a tissue web to be created with multiple zones having different elevations and thicknesses or densities. Also related is US Pat. No. 5,972,813 issued to O. Polat et al. issued Oct. 26, 1999, which discloses an impervious texturing web.

Summary of the Invention

The technology for producing textured webs as described in the above-referenced Ampulski patents and other related references can be improved by shearing the web as it

is also being compressed to create a variety of benefits such as but not limited to any one of: better molding of the web, enhanced mechanical and absorbency properties, and textures or geometries of the web not easily achieved heretofore, particularly structures comprising asymmetrical protrusions in a tissue web. Further improvements, alone or in
5 combination with the application of shear, are possible through the use of novel deflection members, such as those capable of creating asymmetrical protrusions in a web when the deflection member is pressed against the web.

Useful deflection members can include conventional deflection members known in the art of imprinting, as well as novel fabrics formed with elastomeric components, those
10 comprising asymmetrical geometries in the raised elements, those comprising two or more subsets of raised elements having different material properties or geometries, and other fabrics with novel construction and materials as described hereafter. The application of such deflection members of the present invention can, in some embodiments, further be improved through the addition of shear onto the paper web for better molding against
15 the fabric, or through use of an impervious, flexible film on the side of the paper web not in contact with the deflection member to increase the molding due to air pressure differentials applied across the web. In the latter case, the flexible film may be smooth or comprise a texture, and optionally may comprise apertures to decrease the molding in selected regions or to provide pinholes for producing a selectively apertured tissue web.

Webs with asymmetrical domes can offer a variety of potential advantages. For
20 example, an asymmetrical dome can offer unique tactile properties. In some embodiments, the dome may be more flexible or deformable for a soft feel. In other embodiments, tissue comprising asymmetrical domes can have bi-directional frictional properties, meaning that the frictional properties along a pathway (e.g., the machine
25 direction or cross-direction) depend on the direction of travel (forwards or backwards along that path). Thus, a tissue may feel smooth when it brushes against the skin in one direction, but offer higher friction for cleaning when the direction is reversed. When measured with standard dynamic methods for coefficient of friction, frictional properties of the tissue in any one direction can be substantially greater than the coefficient in the
30 opposite direction.

As used herein, the term "deflection member" refers to a textured fabric having a web contacting surface comprising raised elements and having deflection conduits, such that the fabric is capable of imparting texture to a web when the web is pressed or urged against the deflection member, particularly when the web is moist (e.g., having a moisture
35 content of 30% or above, more specifically about 60% or above, more specifically still

about 70% or above, and most specifically from about 75% to about 90%, with an exemplary range of from about 30% to about 55%). The deflection member can impart texture to a web by serving as:

- 5 • an imprinting fabric, wherein the fabric presses the web against a solid surface such as a Yankee dryer, to which the web typically remains attached until creped off by a doctor blade;
- a textured press fabric, wherein the fabric is pressed against the web in a compressive nip, typically with one or more additional fabrics or deformable belts present in the nip;
- 10 • a through drying fabric, wherein differential air pressure forces the web to deform against the texture the of fabric;
- a transfer fabric, in which the web is transferred to the fabric over a vacuum shoe to cause the web to deform against the fabric, including conditions of differential velocity transfer in which the web travels to the fabric at a higher
- 15 speed than the fabric; or
- by serving in any combination of the above roles; or in other embodiments in which a force urges a fibrous web against the fabric under conditions capable of imparting texture to the web.

Brief Description of the Drawings

20 FIG. 1 depicts a paper machine according to the present invention.

 FIGS. 2A and 2B depict a press nip in which a web of moist tissue is transferred from a carrier fabric to a deflection member.

 FIGS. 3A and 3B depict profiles of imprinted domes that can be generated according to the present invention.

25 FIGS. 4A-4C depict embodiments of the deflection member having variable thickness in the raised elements from the base to the top of the element.

 FIGS. 5A-5H depict embodiments of the deflection member having raised elements comprising two zones of differing materials.

 FIGS. 6A-6C show machine-direction cross-sections of deflection members

30 comprising raised elements having a plurality of differing subsets.

 FIG. 7 depicts a deflection member that is impervious.

 FIG. 8 depicts a deflection member having two subsets of raised elements differing in height.

FIGS. 9A and 9B depict a top view and cross-sectional view of a deflection member having a continuous pattern of raised elements attached to a woven base fabric.

FIG. 10 is a perspective view of a portion of a deflection member comprising raised elements in the form of parallel bars attached to a woven substrate.

5 FIG. 11 is a perspective view of a portion of a deflection member showing part of a raised element attached to a woven substrate.

FIG. 12 is a cross-sectional view of a nip in a long shoe press wherein a moist paper web is transferred to a deflection member and molded thereon.

Detailed Description

10 FIG. 1 depicts a portion of a paper machine 30 for production of molded, through-dried, creped tissue 50. A wet paper web 32 produced by a gap former (not shown), crescent former, Fourdrinier, or other formation method known in the art is provided on a deformable carrier fabric 34, which, by way of example, may be a conventional papermaking felt capable of dewatering a moist web in a press nip 35; or may be a felt
15 having a three-dimensional structure for water removal and application of texture, such as the Spectra™ fabrics of Voith Fabrics (Raleigh, North Carolina, formerly produced by the Scapa Group North America, Shreveport, LA), which employ polyurethane components or other polymer networks in the felt in the form of a porous membrane (see G. Rodden, "Nonwovens and Laminates Make their Way into Press Felts," *Pulp and Paper Canada*,
20 vol. 101, no. 3, pp. 19-23, March 2000); or may be the nonwoven molding substrates of Lindsay and Burazin in US Patent No. 6,080,691, "Process for Producing High-Bulk Tissue Webs Using Nonwoven Substrates," issued June 27, 2000, herein incorporated by reference; or may be the marking felts of Voith Fabrics (Raleigh, North Carolina, formerly produced by the Scapa Group Ltd.) disclosed by P. Sudre, "Papermakers Marking Felt,"
25 European Patent Application 0 672 784-A1, published Sept. 20, 1995; or can be the drilled nonwoven webs of Hans Albert disclosed in US Pat. No. 4,541,895, issued Sept. 17, 1985, herein incorporated by reference, and the like. In one embodiment, the deformable carrier fabric 34 is an apertured polymeric press fabric comprising a woven textile base, an apertured polymeric layer, and batt fibers, such as the fabrics described by J. Hawes,
30 "Apertured Structures: A New Class of Porous Polymeric Press Fabrics," *Pulp and Paper Canada*, Vol. 100, No. 2, Dec. 1999, pp. T375-377, with specific examples manufactured by Albany International Corp., Albany, NY. In related embodiments, the woven textile base in the deformable carrier fabric 34 can be replaced with a nonwoven spiral fabric, which is formed by assembly of monofilament helical coils joined by pintles. Spiral fabrics are

described by M. Di Ruscio in "Spiral Fabrics as Dryer Fabrics," *PaperAge*, Jan. 2000, pp. 20-23, and are available from Albany Corp. (Albany, NY).

Prior to being disposed on the deformable carrier fabric 34 or while thereon, the web 32 may be dewatered by any means known in the art, including foils, vacuum boxes, capillary dewatering devices, infrared or microwave drying, pneumatic dewatering, including the displacement dewatering devices as described by J.D. Lindsay, "Displacement Dewatering To Maintain Bulk," *Paperi Ja Puu*, vol. 74, No. 3, 1992, pp. 232-242, or the air press disclosed in WO 99/23296 by D.V. Lange, published May 14, 1999, or in US Patent Nos. 6,080,279, issued June 27, 2000 to Hada et al.; 6,083,346, issued July 4, 2000 to Hermans et al.; 6,096,169, issued Aug. 1, 2000 to Hermans et al.; and 6,093,284, issued July 25, 2000 to Hada et al., all of which are herein incorporated by reference; and the like.

As the web 32 is carried by the underlying deformable carrier fabric 34, it passes through the press nip 35 between two opposing press surfaces 37, 38 capable of applying suitable pressure to partially dewater the moist web 32. The web contacts a deflection member 36 in the nip. The deflection member 36 can be a substantially macroplanar fabric having deflection conduits and elevated regions, and can correspond to any of the fabrics disclosed in US Patent No. 5,679,222, issued Oct. 21, 1997 to Rasch et al.; US Patent No. 4,514,345, issued Apr. 30, 1985 to Johnson et al.; US Patent No. 5,334,289, issued Aug. 2, 1994 to Trokhan et al.; US Patent No. 4,528,239, issued July 9, 1985 to Trokhan; and US Patent No. 4,637,859, issued Jan. 20, 1987 to Trokhan, all of which are herein incorporated by reference.

The interaction of the deflection member 36 with the web 32 and the deformable carrier fabric 34 in the nip 35 results in a texture imparted to the web 32, as described below. The nip 35 can have a machine direction length of at least about 2 inches, more specifically 3 inches, and most specifically from about 4 inches to about 15 inches, and can comprise opposed convex and concave compression surfaces. Here the opposing press surfaces 37, 38 are depicted as simple press rolls 52, 54, though press surfaces 37, 38 could be provided by a variety of devices known in the art, including long nip presses with hydraulic shoes in either open or closed form, such as the high intensity nips disclosed by M.A. Hermans et al. in WO 97/43483, published Nov. 20, 1997, the shoe nips disclosed in US Patent No. 5,897,745, issued Apr. 27, 1999 to Ampulski et al., herein incorporated by reference, or the nips and press equipment disclosed in US Pat. No. 6,036,820, issued March 14, 2000 to C. Schiel et al.; US Pat. No. 5,650,049, issued July 22, 1997 to Kivimaa et al., US Pat. No. 5,662,777, issued Sept. 2, 1997 to Schiel et al., or

Patent Application WO 95/16821, published June 21, 1995 in the name of C.J. Mentele; crown compensated rolls with internal hydraulics for controlling applied pressure; one or more soft rolls with deformable covers; a hard roll in opposition to a suction roll in which vacuum dewatering occurs through drilled holes in the suction roll's surface; and opposing

5 steel bands urged together by applied pressure behind at least one band, such as the CONDEBELT™ drying system of Valmet Corp. (Finland). Condebelt™ technology is disclosed in US Pat. No. 4,112, 586 issued Sep. 12, 1978; US Pat. Nos. 4,506,456 and 4,506,457 both issued Mar. 26, 1985; US Pat. No. 4,899,461 issued Feb. 13, 1990; US Pat. No. 4,932,139 issued Jun. 12, 1990; and US Pat. No. 5,594,997 issued Jan. 21,

10 1997, all foregoing patents issued to Lehtinen; US Pat. No. 4,622,758 issued Nov. 18, 1986 to Lehtinen et al.; and US Pat. No. 4,958,444 issued Sep. 25, 1990 to Rautakorpi et al., all of which are herein incorporated by reference. In a further embodiment, one of the opposing press surfaces 37, 38 can be a capillary dewatering device according to US Patent No. 4,556,450, issued Dec. 3, 1985 to Chuang et al.; US Patent No. 5,701,682,

15 issued Dec. 30, 1997 to Chuang et al.; or US Patent No. 5,699,626, issued Dec. 23, 1997 to Chuang et al., all of which are herein incorporated by reference. In a related embodiment (not shown), the deformable backing fabric 56 is removed and the upper press surface 38 is a capillary dewatering roll which removes water from the web 32 through openings in the deflection member 36 and which assists in web transfer to the

20 deflection member 36 from the deformable carrier fabric 34.

Shoe presses or long nip presses, if used, can modify the performance of pressing systems by providing prolonged, controlled pressure pulses for good sheet molding at lower peak pressures. Commercially available examples of such presses include the ENP (Extended Nip Press) of Beloit Corp. (Beloit, Wisconsin), such as the ENP-C which can

25 operate as a single-felted or double-felted press, or the Tandem NipcoFlex press of Voith (Appleton, Wisconsin), and the OptiPress of Valmet Corp. (Helsinki, Finland). Deformable felts and belts are also helpful in molding a web 32 and dewatering the web 32 against the deflection member 36 in an extended nip press, such as a press having a shoe that provides compression times of over 5 ms and more specifically over 15 ms, with peak

30 loads that can be less than 1500 psi, more specifically less than 800 psi and more specifically still less than 500 psi. In one embodiment when a shoe press or long nip press is used, the web 32 can comprise resilient fibers such as mercerized fibers or chemically stiffened or crosslinked fibers can be used to resist compression of the compression nip and maintain a high bulk product, as further described in WO 97/43483, published Nov.

35 20, 1997 by M.A. Hermans and C.E. Friedbauer.

In the press nip 35, a first surface of the paper web 32 resides on the deformable carrier fabric 34, and the opposing surface contacts an deflection member 36 which can be further supported by a deformable backing fabric 56. The deformable backing fabric 56 can be a conventional papermaking felt or any of the other deformable fabrics disclosed
5 herein or known in the art suitable for use as the deformable carrier fabric 34. However, in one embodiment, no deformable backing fabric 56 is used, and in a related embodiment, the deflection member 36 has deformable properties such as sponge-like elements or elastomeric support elements that at least partially eliminate the motivation to employ a deformable backing fabric 56 in order to get good press performance and web molding in
10 the nip 35.

The deformable backing fabric 56 has an overall permeability which may be the same as, greater than, or less than the permeability of the deformable carrier fabric 34. In one embodiment, the permeability of the deformable carrier fabric 34 is less than the permeability of the deformable backing fabric 56, following the teachings of Ampulski et
15 al. in US Patent No. 5,776,307, "Method of Making Wet Pressed Tissue Paper with Felts Having Selected Permeabilities," issued July 7, 1998, herein incorporated by reference, wherein the deformable carrier fabric 34 of the present invention corresponds to the first felt of Ampulski et al. and the deformable backing fabric 56 herein corresponds to the second felt therein. In this embodiment, the deformable backing fabric 56 can have an air
20 permeability which is greater than the air permeability of the deformable carrier fabric 34. The deformable backing fabric 56 can have an air permeability which is at least about 1.5 times greater than the air permeability of the deformable carrier fabric 34 and more specifically at least 2.0 times greater than the air permeability of the deformable carrier fabric 34. The relatively high permeability of the deformable backing fabric 56 in such
25 embodiments allows water to be easily removed from the deformable backing fabric 56 both upstream and downstream of the compression nip, such as with one or more vacuum devices.

In general, the deformable backing fabric 56 can have an air permeability of about
20 cubic feet per minute per square foot or greater, specifically about 30 cubic feet per
30 minute per square foot or greater, and more specifically about 40 cubic feet per minute per square foot or greater. In one embodiment, the deformable backing fabric 56 has an air permeability which is between about 50 and about 150 cubic feet per minute per square foot.

Likewise, the deformable carrier fabric 34 can have an air permeability of about 10
35 cubic feet per minute per square foot or greater, specifically about 20 cubic feet per

minute per square foot or greater, and more specifically about 30 cubic feet per minute per square foot or greater. In one embodiment, the deformable carrier fabric 34 has an air permeability which is between about 40 and about 120 cubic feet per minute per square foot.

5 The deformable carrier fabric 34, the deformable backing fabric 56 and the deflection member 36 are all guided and controlled in their motion by a series of rolls 40 known in the papermaking arts.

 In one embodiment, a degree of shear is imposed on the web 32 as it contacts and is transferred to the deflection member 36. Shear can be provided by several means,
10 such as differential velocity between the two deformable fabrics 34, 36; or by using of a soft, deformable roll cover on one or more rolls 52, 54 in the nip 35 such that deformation of the roll surface(s) 37 and/or 38 causes in-plane (machine direction) shear of the web (e.g., momentary deceleration coming into the nip and momentary acceleration after the midpoint of the nip); or by in-plane flexure of the deflection member 36 as it is
15 compressed, such that the distance between any two points in the machine direction of the web is not rigidly fixed as the deflection member 36 is compressed, but that there is a degree of local in-plane deformation in the machine direction in response to z-direction mechanical pressure by the nip 35; or the like. Alternatively, the shear can be due to nonuniform deformation of the deflection member 36 in the nip 35, as described in more
20 detail below.

 In one embodiment for creating shear, differential velocity exists in the press nip 35. In this embodiment, the deformable carrier fabric 34 and the wet web 32 move at a first velocity, while the deflection member 36 and the deformable backing fabric 56 move at a second velocity. The first velocity can be substantially the same as the second
25 velocity, but in one embodiment a difference exists of from about 1% or more, such as from about 2% to 40%, or from about 3% to 30%, or about 5% or more. In terms of absolute velocity differences, the velocity difference between the two fabrics can about 0.2 m/s or greater, about 0.5 m/s or greater, 1 m/s or greater, or from about 0.1 m/s to about 2.5 m/s. When the second velocity is less than the first velocity, a phenomenon
30 known as rush transfer occurs, in which the web 32 is foreshortened as the faster moving deformable carrier fabric 34 rushes the web 32 against the slower moving deflection member 36, which can improve the degree of molding provided by the deflection member 36 and can increase the machine direction stretch of the web 32. For rush transfer to be effective, conditions in the nip 35 can be optimized to cause good transfer of the web 32,
35 good foreshortening, and little damage to the web 32. Pressures in the nip 35 may need

to be reduced or optimized to prevent damage to the web 32 and the fabrics 34, 36, 56. For example, nip pressure may be set to less than 1000 pounds per linear inch (pli), or less than 600 pli, or from about 50 to 500 pli, or to less than 200 pli. A steam shower (not shown) can also be installed before the nip 35 to soften the web and improve both water
5 removal and deformability for good molding.

A variety of effects can be achieved with differential velocity between the web 32 and a deformable surface contacting the web 32 (or a flexible but incompressible material backed with a deformable material, permitting deformation during compression). For example, momentary contact with a press felt 34, 56 in a nip 35 moving at a different
10 velocity than the web 32 itself can cause added deformation of the web 32, wherein fibers on the macroplanar surface of the deflection member 36 tend to be moved in one direction while the fibers in the deflection conduits 62 are fixed. The result can be shear thinning of some regions and shear thickening of others. For example, the region between two nearby deflection conduits 62 spaced apart in the machine direction will be thickened
15 near one conduit and thinned near the other. Alternatively, some regions on the macroplanar surface will be densified relative to others due to the shearing effect of differential velocity contact. The resulting web 32 can have 1) a first relatively high density region optionally having a random or periodic variation in the machine direction in thickness and/or density and having a first range of elevation, 2) a second relatively low
20 density region having a second thickness, which is a local maximum generally corresponding to the central regions of domes formed in the deflection conduits, and 3) a third region extending intermediate the first and second regions having a third thickness, which is a local minimum generally corresponding to the sides or bases of the domes formed in the deflection conduits 62.

As the web 32 is pressed against the deflection member 36, water will generally be
25 expelled and either pass through the deflection member 36 into the deformable backing fabric 56 or pass into the deformable carrier fabric 34 or both, depending on the permeability of the deflection member 36 and the permeability and moisture content of the deformable fabrics 34, 36, and the presence of suction, drilled holes or grooves in one or
30 more of the opposing press surfaces 37, 38, and other conditions of the nip 35. In one embodiment, the deflection member 36 has deflection conduits in fluid communication with the deformable backing fabric 56 such that water can pass from the web 32 in the nip 35 toward the deformable backing fabric 56. In another embodiment, the deflection member 36 is substantially impervious, with water removal directed primarily toward the
35 deformable carrier fabric 34.

After transfer to the deflection member 36, the web 32 can be further molded against the deflection member 36 by one or more of:

- through drying with differential air pressure pressing the web 32 against the deflection member 36, as in the through dryer 42 shown in FIG. 1;
- 5 • dewatering and deforming the web with an air press;
- using the deflection member 36 to press the web 32 against a solid surface such as a drum dryer or Yankee cylinder 46 also shown in FIG. 1, from which a dried web 50 may then be creped with a crepe blade 48, as shown in FIG. 1, or removed without creping (not shown), with methods such as those
- 10 disclosed in commonly owned US application Ser. No. 09/961773, "Method of Producing Low Density Resilient Webs," filed Oct. 31, 1997; and the like.

Principles of molding a web 32 on a drum dryer or Yankee dryer 46 without creping are disclosed by F. Druecke et al. in commonly owned US application Ser. No. 09/961773, "Method of Producing Low Density Resilient Webs," filed Oct. 31, 1997, herein

15 incorporated by reference, which discloses combinations of adhesive and release agent which can permit the web 32 to adhere to the drum dryer or Yankee 46 for effective heat transfer but also can permit the dried web 50 to be pulled off the dryer 46 without the need for creping. Other relevant teachings are found in commonly owned US application Ser. No. 09/961913, filed Oct. 31, 1997, by S.L. Chen et al. (see also WO 99/23299 and WO

20 99/23298, both of which were published May 14, 1999); US Patent No. 6,080,279, issued June 27, 2000 to Hada et al.; US Patent No. 6,083,346, issued July 4, 2000 to Hermans et al.; and in US Patent No. 5,336,373, issued Aug. 9, 1994 to Scattolino et al., all of which are herein incorporated by reference. Relevant information on dewatering and pressing of a fabric against a Yankee is also disclosed in US Patent No. 6,096,169,

25 issued Aug. 1, 2000 to Hermans et al. and US Patent No. 6,093,284, issued July 25, 2000 to Hada et al., previously incorporated by reference.

The use of through dryer 42 as shown in FIG. 1 is not essential, but is intended to show one of many means available for further molding a web 32 against a deflection member 36 and/or for further dewatering or drying a web 32. Uncreped tissue webs and

30 through-dried uncreped tissue webs in particular are within the scope of the present invention. US Patent No. 5,932,068, issued Aug. 3, 1999 to Farrington, Jr. et al., herein incorporated by reference, discloses one of many known means for producing soft, uncreped tissue webs. The principles therein can be adapted for use in the present invention, such as layering of the web 32, differential velocity transfer, noncompressive

drying of the web 32 (which can be applied after pressing in the present invention), and chemical or mechanical modification of the fibers.

When throughdrying is used, many different configurations and systems can be used. For example, heated air may pass from a hood 44 into the throughdrying cylinder 5 42, or from the throughdrying cylinder 42 into the hood 44 as depicted in FIG. 1, or from a flat hood (not shown) into a flat vacuum box (not shown). Throughdrying may be performed in a series of steps with air flow alternating in direction or consistently in one direction. For example, there may be a first cylindrical through dryer 42 followed by a flat through dryer (not shown).

10 In one embodiment, the web is further molded against the deflection member 36 by pressing the web 32 and the deflection member 36 against the throughdryer 42 with a press roll (not shown), which can be positioned near the point where the web first comes into proximity with the throughdryer 42.

The dryer drum 46 need not be a steam-filled roll but may be any heated drying 15 surface known in the art, such as an internally heated gas-fired roll (ABB Flakt's Gas Heated Paper Dryer), an inductively heated drying roll, an impulse drying roll such as those disclosed in US Patent No. 5,353,521, issued Oct. 11, 1994 to Orloff; and US Patent No. 5,598,642, issued Feb. 4, 1997 to Orloff et al., other drying technologies described by R. James in "Squeezing More out of Pressing and Drying," *Pulp and Paper* 20 *International*, Vol. 41, No. 12 (Dec. 1999), pp. 13-17, and the like. The dryer drum can also be a Hot Roll Press (HRP), as described by M. Foulger and J. Parisian in "New Developments in Hot Pressing," *Pulp and Paper Canada*, 101(2): 47-49 (Feb. 2000). The HRP comprises a thermal fluid heated Tri-Pass II press roll, supplied by SHW, Inc. (Germany), with a ceramic or fluoropolymer coating for good web release. A paper web is 25 pressed onto the heated HRP roll, which rides on the roll until it is removed from the drum by contact with another fabric in a nip against another roll.

Many other embodiments are within the scope of the present invention. For example, an additional foraminous backing member (not shown) can be disposed between one of the deformable fabrics 34, 56 and the respective pressing surface 37, 38 30 to provide additional void volume for receiving water when one or more of the compressed deformable fabrics 34, 56 in the nip 35 is near its saturation point. The foraminous backing member (not shown) can be an additional endless web that can have a void volume capable of receiving about 100 grams or more of water per square meter or about 200 grams per square meter, or between about 300 and about 600 grams per square 35 meter. The foraminous backing member can also have a compressibility of less than

about 50 percent so that the void volume of the foraminous backing member remains open while the foraminous backing member is passing through the nip. The foraminous backing member can be formed from woven filaments or can be a spiral fabric, and can be in the form a continuous belt. In another embodiment, the foraminous backing member
5 can comprise a patterned resin layer. In one embodiment, the foraminous backing member comprises a patterned resin layer joined to a dewatering felt layer. For instance, the patterned resin layer can be joined to the deformable carrier fabric 34.

In another embodiment, a plurality of texture-generating surfaces are present in the nip 35, such that there is an interaction between the texture of the deflection member
10 36 and the texture of other surfaces. For example, the other texture-generating surfaces can be one or more of the deformable fabrics 34, 56, and/or one or both of the press surfaces 37, 38. Thus, there is an interaction between the plurality of texture-generating surfaces in the nip 35 which in turn provide a texture to the web 32 that would not be achieved by the use of a single deflection member 36 as the sole texture-generating
15 surface.

In another embodiment, before, during, or after the pressing invention, the paper web 32 may also be contacted with a flexible web (not shown) having an air permeability less than the air permeability of the underlying fabric 34 or 36 on which the paper web is disposed. The paper web 32 is overlaid with the flexible web and exposed to an air
20 pressure gradient such that the flexible web deflects toward the underlying fabric 34 or 36 and further promotes at least one of water removal from the paper web and molding of the paper web. The flexible web can have a degree of surface texture which can be imparted to the upper surface of the paper web during pressing or application of air pressure differentials. Principles for the use of a flexible sheet against a paper surface on a
25 papermaking belt are disclosed by P.D. Trokhan and V. Vitenberg, US Pat. No. 5,893,965, issued April 13, 1999, previously incorporated by reference.

In an alternative embodiment (not shown) to that of FIG. 1, the web 32 can reside on the deflection member 36 as it approaches the nip 35, rather than residing on the deformable carrier fabric 34. In such an alternative embodiment, the web 32 would
30 generally remain on the deflection member 36 as it passes though the nip 35, rather than being transferred from one fabric to another in the proximity of the nip 35, though a transfer could be established, if desired, followed by another transfer to the deflection member 36 or to another textured fabric for further molding or drying. The embodiment depicted in FIG. 1 permits a differential velocity transfer to occur from the deformable

carrier fabric 34 to the deflection member 36, which would not be possible if the web is on the deflection member 36 before the nip 35 and remains thereon until well after the nip 35.

Additional differential velocity transfers may occur outside of the nip, wherein the paper web 32 is transferred from one fabric to a second fabric moving at a different
5 speed. Differential velocity transfer from one fabric to another can follow the principles taught in any one of the following patents: US Patent No. 5,667,636, "Method for Making Smooth Uncreped Throughdried Sheets," issued Sep. 16, 1997 to Engel et al., herein incorporated by reference; US Patent No. 5,830,321, "Method for Improved Rush Transfer to Produce High Bulk Without Macrofolds," issued Nov. 3, 1998 to Lindsay and Chen,
10 herein incorporated by reference; US Patent No. 4,440,597, "Wet-Microcontracted Paper and Concomitant Process," issued Apr. 3, 1984 to Wells and Hensler; US Patent No. 4,551,199, "Apparatus and Process for Treating Web Material," issued Nov. 5, 1985 to Weldon; and US Patent No. 4,849,054, "High Bulk, Embossed Fiber Sheet Material and Apparatus and Method of Manufacturing the Same," issued July 18, 1989 to Klowak.
15 Thus, by way of example, differential velocity transfer may be used to transfer an embryonic paper web 32 from a forming fabric onto the deformable carrier fabric 34, or from the deflection member 36 onto a separate through drying fabric. When rush transfer is used, the degree of rush transfer may be about 5% or more, more specifically about 15% or more, and most specifically about 30% or more, to impart improved machine
20 direction stretch (e.g., levels of about 10% or greater) to the dried web 32 and/or to improve the degree of molding or to modify the texture of the web 32.

To assist in removal of the web 32 from the deflection member 36 when the web 32 is pressed against the drying drum 46, the deflection member 36 can be sprayed or coated with release agents prior to contact with the web 32. Such release agents can
25 include fluoropolymers, silicone compounds, or oil-water emulsions, and specifically can include an emulsion comprising about 90 percent by weight water, about 8 percent petroleum oil, about 1 percent cetyl alcohol, and about 1 percent of a surfactant such as Adogen TA-100.

FIGS. 2A and 2B show the action of a compression nip 35 on a paper web 32 in
30 contact with a deflection member 36, with the direction of the web 32 being from left to right. In FIG. 2A, the deflection member 36 has a geometry similar to those known in the prior art, while a more complex deflection member 36 is depicted in FIG. 2B. Both FIGS. 2A and 2B depict the deformation in the web 32 and deformable carrier fabric 34 that can occur in the nip 35. The deflection member 36 comprises at least one pattern of raised
35 elements 60 forming a web densifying surface 61 (in the sense that a web 32 would be

selectively densified by the web densifying surface 61 if pressed against the raised elements 60) and defining a pattern of deflection conduits 62 between the raised elements 60. The web densifying surface 61 occupies a fraction of the entire web contacting surface of the deflection member 36. The web 32 can deform under pressure into the deflection 62 conduits and water can pass therethrough to the deformable backing fabric 56 if the deflection member 36 is sufficiently permeable and if the hydraulic driving force for water transport is sufficient.

In FIG. 2B, the raised elements 60 have a base 81 which is attached to a base fabric 64 (a foraminous element), and have an upper portion 83, which is wider than the base portion 81, depicted as a mushroom shape in the embodiment of FIG. 2B, in contrast to FIG. 2A. The raised elements 60 are also depicted as being adequately deformable to deform during compression, and to be skewed in the machine direction when the deformable carrier fabric 34 is moving faster than the deflection member 36. The skewing of the resilient raised elements 60 in a nip with rush transfer present further contributes to the asymmetry of the protrusions 68 formed in the paper web 32.

In both FIGS. 2A and 2B, the deformable carrier fabric 34 can deflect into the deflection conduits 62 to form a local mound 66 of the deformable carrier fabric 34 and also a protrusion 68 in the web 32. The protrusion 68 of this embodiment can be generally asymmetrical when viewed along a machine-direction cross-section, or particularly in the machine direction cross-section that passes through the longest span in the machine direction of the structure under scrutiny. (For example, with diamond-shaped deflection conduits aligned with the machine direction, the longest span in the machine direction for assessing symmetry of the walls of the deflection conduit would be a line from one vertex to the opposing vertex.) Without wishing to be bound by theory, the asymmetry of the protrusion 68 can be caused or enhanced by differential velocity transfer, in which the higher speed of the deformable carrier fabric 34 rushes some of the paper web toward the raised elements 60 of the deflection member 36, causing fibers to accumulate toward the trailing side of the raised elements 60. The shape of the raised elements 60 and their deformation in the compression nip 35 can also contribute to asymmetry of the protrusions 68 of the web 32, even when no differential velocity is present in the nip, if the element is asymmetrical and/or if the raised elements 60 become asymmetrical during compression as can be the case when the raised elements 60 are heterogeneous structures comprising two or more materials having different elastic properties, and/or if the raised elements 60 comprise an elastomeric material permitting temporary distortion

of the raised elements 60 in the direction of shear within in the compressive nip, as is depicted in FIG. 2B.

The molded web 32 will tend to have a pattern of protrusions 68. The web 32 will tend to have a first relatively high density region 80 where the web has been pressed with the raised elements 60, and a relatively low density region 76 generally corresponding
5 with the protrusions 68.

Though the simple base fabric 64 shown in FIGS. 2A and 2B is relatively flat, three-dimensional base fabrics can be used, including both woven and nonwoven structures, and double layer and triple layer fabrics, including those with ovate or flat
10 yarns, such as the fabrics disclosed in US Pat. No. US Patent No. 5,379,808, issued Jan. 10, 1995 to Chiu. Examples of three-dimensional woven base fabrics include the sculpted fabrics disclosed in US Patent No. 5,429,686, issued July 4, 1995 to Chiu et al., herein incorporated by reference. The sculpted fabrics disclosed therein (not shown) have
15 strands that rise above the plane of the fabric to create an enhanced three-dimensional structure. For purposes of the present invention, such fabrics could be modified by adding resin to form a deflection member having raised elements formed from the resin in a repeating pattern, superposed on the existing three-dimensional woven structure, such that the added raised elements are suitable for densifying the portions of a paper web in contact with the resin in an imprinting operation or a wet pressing event or other operation
20 in which the web is pressed against the deflection member. Thus, the web would receive a primary texture due to the presence of raised elements in a repeating pattern and a secondary texture imparted to the web in the deflection conduits by the three-dimensional woven structure of the base fabric.

In a related embodiment that is not shown, the woven base fabric 64 of the
25 deflection member 36 can be replaced with a nonwoven spiral fabric or other suitable nonwoven, foraminous structures, including the nonwoven apertured fabrics of Albert in US Pat. No. 4,541,895, issued Sept. 17, 1985, previously incorporated by reference.

To improve the transfer of the web 32 from the deformable carrier fabric 34 to the deflection member 36, transfer aids may be useful, including the use of differential air
30 pressure (not shown) to urge the web 32 from the deformable carrier fabric 34 to the deflection member 32. Differential air pressure can be provided if the upper press roll 54 is a suction roll, in which vacuum pressure helps pull the web 32 against the deflection member 36, or if the lower press roll 52 is porous and provides elevated air pressure, or if the upper roll 52 is a suction roll in conjunction with a porous lower roll 54 providing
35 positive air pressure. Release agents may also be applied to the interface between the

web 32 and the deformable carrier fabric 34, and attachment aids such as adhesive or tacky polymers (e.g., polyvinyl alcohol) may be applied to the upper surface of the web 32 or the web densifying surface 61 of the deflection member 36 to promote effective transfer.

5 In some cases, there may be some difficulty in removing a molded web 32 from the deflection member 36 when the web 32 becomes deeply molded into a deflection member 36 with mushroom-shaped raised elements 60 or other raised elements 60 having a cross-sectional shape with a top portion 83 wider than the base portion 81. This difficulty can be overcome by bending the deflection member 36 away from the paper
10 contacting side thereof such that the distance between adjacent raised elements 60 widens, and then removing the web 32. Passing the deflection member 36 over a narrow turning bar (e.g., diameter less than 12 inches, more specifically less than about 8 inches) can be a helpful tool.

FIGS. 3A and 3B depict schematic examples of two profiles 70 in the web 32
15 achievable by the present invention. The profile 70 of FIG. 3A is drawn substantially according to FIG. 8 of Ampulski et al. in US Patent No. 5,904,811, issued May. 18, 1999, herein incorporated by reference. In FIGS. 3A and 3B, each profile 70 represents a two-dimensional unit cell extending from the midpoints 69 of the web 32 above the center of the raised elements 60 of the deflection member 36. Each profile 70 has a point of
20 maximum height, the local maximum 72 on the dome 74, and generally has a local minimum that can correspond with the midpoints 69 of the portion of the web 32 above the center of the raised elements 60 during pressing. In FIG. 3A, the profile 70 is substantially symmetrical about the local maximum 72, representing either a textured web 32 made according to US Patent No. 5,904,811 of Ampulski or according to some
25 embodiments of the present invention with substantially no shear during pressing against the deflection member 36. The molded web 32 has a relatively low density zone 76 around the local maximum with a local thickness P, a high density zone 80 with a relatively lower local thickness K, and an intermediate zone 78 with an intermediate local thickness T. If substantial shear is applied, say, by differential velocity transfer, the relative
30 motion of the deflection member 36 versus the web 32 results in a "snowplow" effect in which moist fibers are sheared and piled up toward one side of the profile 70, resulting in an asymmetrical profile 70 such as that shown in FIG. 3B. The profile 70 of FIG. 3B has a local maximum 72 with a local thickness P and a relatively low density zone 76, and two transition zones 78', 78" at the base of the dome 74 with local thicknesses T1 and T2,
35 respectively. The shearing of the fibers may also result in nonuniform thickness in the high

density zone 80 near the midpoints 69, such that measurement of the thickness halfway from each side of the base of the dome 74 and the midpoints 69 can yield a first local thickness K_1 and a second local thickness K_2 which need not be the same due to the asymmetry caused by shearing. Further, the local maximum 72 need not be along the midpoint line MP (the vertical line which passes through the center of the base below the dome 74, being equidistant from the inner surfaces of the dome 74 at the base of the dome 74), but may be horizontally displaced from the midpoint line MP by a fraction of the width of the dome 74, such as about 6% or more, or about 10% or more, about 15% or more, or from about 10% to about 25% of the width W of the dome 74 measured as the maximum horizontal distance between the outer surfaces at the base of the dome 74. Thus, displacement of the local maximum 72 from the midpoint line MP is evidence of asymmetry in the shape of the dome 74 and in the profile 70 more generally. The profile 70 can also be taken as asymmetrical when the transition ratio, $T_1:T_2$ or $T_2:T_1$, whichever gives a value of 1 or more, is about 1.2 or greater, more specifically about 1.3 or greater, more specifically still from about 1.3 to about 3.0, most specifically about 1.5 or greater, with an exemplary range of from about 1.5 to about 3.5. Another measure of asymmetry is the high density ratio, defined as $K_1:K_2$ or $K_2:K_1$, whichever gives a value of 1 or more, which, for asymmetrical profiles can be 1.1 or greater, more specifically about 1.3 or greater, and more specifically about 1.5 or greater, with an exemplary range of from about 1.4 to about 2.0. Alternatively, the cross-sectional profile 70 of a unit cell can be divided by the midpoint line MP and the total area of the two sides compared using standard image analysis methods. When the area ratio, which is the ratio of the first area (being greater than that of the second area) to the second area, is about 1.2 or greater, such as from about 1.3 to about 2.5, the profile can be taken as asymmetrical. Of course, an asymmetrical profile can have two or more of the above measures (displacement of the local maximum 72 from the midpoint line, the transition ratio, the high density ratio, and the area ratio) giving values within the stated ranges for asymmetry. It is recognized that any one dome 74 may have aberrations in shape or size, so tests for symmetry should be based on a statistical average of 100 randomly selected domes, with profiles taken in a consistent direction and passing through the center of the dome 74, when applicable. The webs 32 of the present invention can have about 40% or greater of the domes 74 exhibiting asymmetry in a cross-sectional profile such as a machine direction profile or cross-direction profile; more specifically about 50% or greater of the domes 74 exhibiting asymmetry in terms of at least one of the measures discussed above and optionally in terms of two or more of the measures discussed above; more specifically still

about 60% or greater of the domes 74 exhibiting asymmetry; and most specifically about 80% or greater of the domes 74 exhibiting asymmetry. In one embodiment, substantially all of the domes will have one or more measure of asymmetry indicating an asymmetrical structure. Asymmetry of the domes 74 for webs 32 of the present invention will generally
5 be present prior to creping and will frequently persist after creping as well, for webs that are creped.

Even though the profile 70 of FIG. 3B has two local thicknesses K1 and K2 depicted in the high density region, a single local thickness K can be ascribed to the region which is the average of K1 and K2, which also can be used to define an average
10 density there. Likewise, a single transition local thickness T can be reported as the average of T1 and T2.

The molded web 32 formed by the process shown in FIG. 1 can have relatively high tensile strength and flexibility for a given level of web basis weight and web caliper H (FIGS. 3A and 3B). This relatively high tensile strength and flexibility is believed to be due,
15 at least in part, to the difference in density between the relatively high density region 80 and the relatively low density region 76. Web strength is enhanced by pressing a portion of the intermediate web 36 between the deformable carrier fabric 34 and the deflection member 36 to form the relatively high density region 80. Simultaneously compacting and dewatering a portion of the web provides fiber to fiber bonds in the relatively high density
20 region 80 for carrying loads. Pressing also can help form the transition region 78, which can provide web flexibility. The relatively low density region 76 deflected into the deflection conduit portions of the deflection member 36 provides bulk for enhancing absorbency. In addition, pressing the web 36 draws papermaking fibers into the deflection conduits to form the intermediate density region 78, thereby increasing the web macro-caliper H
25 (FIGS. 3A and 3B). Increased web caliper H decreases the web's apparent density (web basis weight divided by web caliper H). Web flexibility increases as web stiffness decreases.

The total tensile strength of the web made according to the present invention can be at least about 300 meters. Paper webs made according to the present invention can
30 have a macro-caliper H of at least about 0.10 mm. In one embodiment, paper webs made according to the present invention have a macro-caliper of at least about 0.20 mm, and more specifically at least about 0.30 mm. The procedure for measuring the macro-caliper H are described below.

The paper web made according to the present invention can have densified
35 "knuckles" occupying from about 8% to about 60% of the surface area of the web,

wherein the densified knuckle regions have a relative density of at least 125% of the density of the high bulk region of the web. The knuckles may be relatively rich or deficient in a chemical additive deposited heterogeneously in or on the web 32.

The web 32 need not have a uniform basis weight, but can be formed in such a weight that a pattern of high and low basis weight regions exists in the web 32, or that a pattern is created having three or more basis weight regions. By way of example, Trokhan and Phan in US Pat. No. 5,503,715, issued April 2, 1996, herein incorporated by reference, disclose patterned forming fabrics that are used to create a basis weight pattern in a web having a high basis weight network, and discrete low basis weight regions that circumscribe regions of intermediate basis weight. A web having a patterned basis weight distributed in a first pattern can then be transferred onto a deflection member according to the present invention, wherein the deflection member has second pattern. The second pattern is imparted to the topography of the web 32, which has a first pattern in its basis weight and opacity. The interaction of the two patterns can yield new physical, tactile, and visual properties. For example, referring again to FIG. 3A, when the two patterns are registered, the most elevated regions of the domes 74 (the region containing the local maximum 72) can have an intermediate basis weight, while the depressed regions corresponding to the relatively high density region 80 can also have a relatively high basis weight, while the intermediate zone 78 can have a low basis weight. Other embodiments can be produced, including examples wherein the highest basis weight corresponds to the intermediate zone 78.

When pains are not taken to register the patterns of the forming fabric and the deflection member 36 or when the two patterns have differing frequencies, the basis weight pattern may not be directly correlated with the topographical pattern imparted to the web 32 by the deflection member 36. Thus, in one embodiment, the first pattern of the forming fabric (not shown) and the second pattern of the deflection member 36 of FIG. 1 are not registered, such that the tissue web will comprise two or more subsets of domes 74, with the domes 74 of one subset being characterized by having a relatively high basis weight region associated with the local maximum 72, while the domes of another subset are characterized by having a relatively low basis weight region associated with the local maximum 72. Likewise, the intermediate zone 78 or high density zone 80 can, in any single dome 74, be associated with high, low, or intermediate basis weight zones.

FIGS. 4A-4C depict additional embodiments of the deflection member 36. FIG. 4A depicts the machine direction cross-section of a deflection member 36 wherein the raised elements 60 have a mushroom shape, as in FIG. 2. FIG. 4B depicts elements similar to

those of FIG. 4A, except the central portion of the raised elements 60 comprises an indentation 92, yielding a raised element 60 with an elevation (relative to the base fabric 64) at the upper periphery 94 being greater than the elevation at the upper central portion 96 of the raised element 60. FIG. 4C depicts asymmetrical raised elements 60 having a height maximum at or near a first side 98 of the raised elements 60. The first side 98 corresponding to or closest to the height maximum can be a trailing edge or leading edge of the raised elements 60. When an indentation 92 is present in the raised elements 60, it can have a depth relative to the thickness of the raised element (from the backside to the top side of the raised element 60) of about 40% or less, more specifically about 25% or less, most specifically about 15% or less, with exemplary ranges of from 5% to about 20%, or from about 10% to about 40%.

Numerous other shapes can be depicted having either a top portion wider than the base portion of the raised elements 60, and being either symmetrical or asymmetrical, and having a web densifying surface 61 that can be convex (as FIG. 4A), concave, or both convex and concave, such as a saddle-shape profile (as FIG. 4B). The web densifying surface 61 can be nonlinear (curved) or linear, with linear surfaces being either horizontal or positively or negatively sloped in the machine direction or in the cross-direction.

Asymmetrical raised elements 60 such as those of FIG. 4C can be especially helpful in creating asymmetrical shaped protrusions in the paper web, with or without differential velocity transfer of the paper web to the deflection member 36.

FIGS. 5A-5H depict raised elements 60 comprising two discrete zones of different materials that differ in mechanical or elastic properties to further enhance the asymmetry or other properties of the protrusions created by pressing the deflection member 36 against a paper web (not shown). FIG. 5A depicts a simple symmetrical raised element 60 having a first material 100 and a second material 102 separated by a vertical interface 104. In one embodiment, the first material 102 differs substantially from the second material 104 in material properties such as elastic modulus, Poisson ratio, or storage modulus, such that in a press nip, the raised element 60 will not form a symmetrical structure during compression but will be asymmetrical, such as a skewed structure or one that bulges more in one direction (e.g., the forward or reverse machine directions). Alternatively or simultaneously, the two material zones 100, 102 optionally coupled with an asymmetrical shape of the raised elements 60 yield a web that is densified more in the portions contacting one of the two materials 100, 102 than in the portions contacting the other of the two materials 100, 102.

FIG. 5B depicts a layered raised element 60 wherein the interface 104 dividing the first material 100 from the second material 102 is substantially horizontal. The interface 104 in FIG. 5C is at an angle relative to the horizon (for a base fabric 64 lying in the horizontal plane), such as from about 20 to 70 degrees, with about 45 degrees being depicted. FIG. 5D shows that the interface 104 can be defined by more than one line, here having both horizontal and vertical components. FIGS. 5E to 5H show that other shapes can be employed. FIG. 5E depicts a mushroom-shaped raised element 60 having an interface 104 with a minimum elevation relative to the base fabric near the center of the raised element 60. FIG. 5F depicts another mushroom-shaped raised element 60 with a vertical interface 104. FIG. 5G depicts an asymmetrical raised element 60 with side having a portion that extends over the base of the raised element 60, wherein the upper portion of the raised element 60 comprises a first material 100 and a lower portion comprises a second material 102. FIG. 5H depicts a vertical interface 104 between two materials 100, 102 in an asymmetrical raised element 60 wherein one side (e.g., the trailing side) is more elevated and wider than the other side (e.g., the leading side).

FIGS. 5A--5D show raised elements 60 having straight sides ascending from the base fabric 64 in a straight line, whereas the sides of the raised elements 60 in FIGS. 5E-5H include nonlinear (including curved) sections. In general, the sides or walls of raised elements 60 and deflection conduits 62 of the imprinting fabric 36 can be linear or nonlinear. In nonlinear embodiments, one or both sides of the raised element 60 when viewed in a two-dimensional cross-section (e.g., CD or MD cross-section) can exhibit a profile with one or two nonlinear sides. The use of nonlinear sides is expected to provide texture and tactile properties beyond what can be achieved with linear raised elements. For example, domes in the finished paper web 32 may be more rounded or visually appealing than those produced with typical imprinting fabrics, though tactile results will depend upon a myriad of other factors as well.

FIGS. 6A-6C show machine-direction cross-sections of deflection members 36 comprising raised elements 60 having a plurality of subsets differing in shape, material properties, and/or height. FIG. 6A, for example, depicts a deflection member 36 having a first subset 108 of raised elements 60 having a saddle shape, and having a second subset 110 of raised elements 60 having a mushroom shape. Though only two subsets have been depicted, any number of subsets could be employed, such as 3, 4, 5, or 6 subsets, with the raised elements 60 of each subset arrayed in repeating patterns or in non-repeating patterns, including random patterns or non-repeating tilings such as a Penrose pattern or the amorphous patterns of US Patent No. 5,965,235, "Three-

Dimensional, Amorphous-patterned, Nesting-resistant Sheet Materials and Method and Apparatus for Making Same," issued Oct. 12, 1999 to McGuire et al.

The first subset 108 may be continuous, forming, for example, a grid or network such as a rectilinear grid, while the second subset 110 (or other subsets) may comprise discrete islands of raised elements 60 surrounded by the network of the first subset 108. Any number of such patterns can be contemplated within the scope of the present invention.

FIG. 6B is similar to FIG. 6A except that the second subset 110 has a rounded dome shape and has a lower elevation than the first subset 108 of raised elements 60. In FIG. 6C, the raised elements 60 of both the first subset 108 and the second subset 110 have similar asymmetrical shapes and elevations, but the first subset 108 is reversed relative to the second subset 110, meaning in this case that the side closest to the maximum in elevation is the trailing edge for one subset and the leading edge for the other (i.e., the first subset 108 is a mirror image of the second subset 110). The raised elements 60 of FIG. 6C have a top portion dominated with a sloped surface having a slope of up to about 45° from horizontal. Raised elements 60 in general need not be substantially flat but can have a dominant sloped portion having a departure from the horizontal of about 10 degrees or more, more specifically about 20 degree or more, and more specifically about 30 degrees or more, such as from about 15 degrees to about 50 degrees.

The first and second subsets 108, 100, respectively, may also comprise different materials having different elastic and mechanical properties such that one subset behaves differently in compression than the other subset. Differences in compression will also arise even with the same material being used in both subsets (or in all subsets, when more than two subsets of raised elements 60 are used).

When a deflection member 36 having two or more subsets of raised elements 60 is pressed against a paper web in a compression nip, wherein one subset deforms substantially more than another subset or exhibits different compressive behavior, the result can be nonuniform deformation of the web 32. Without wishing to be bound by theory, it is believed that such nonuniform deformation can yield local regions of shear where the web 32 is relatively more elongated in the plane of the web 32 than neighboring portions of the web 32. Such a mechanism can modify the way in which the web is texturized by the deflection member 36, resulting in properties and structures not heretofore achievable with conventional imprinting technology.

FIG. 7 shows another embodiment of the deflection member 36, wherein the deflection member 36 is substantially impervious, and can be made according to the teachings of US Patent No. 5,972,813, issued Oct. 26, 1999 to Polat et al., herein incorporated by reference. The deflection member 36 of FIG. 7 is based on the fabric of Polat et al., and comprises two primary components: a framework 86 and a reinforcing structure 84, which, as depicted here, comprises a woven base fabric 64. The framework 86 is disposed on the sheet side of the deflection member 36 and defines the texture. The framework 86 comprises two subsets of raised elements, 60' and 60", with the first subset 60' having a greater height than the second subset 60". Either the first or second subsets, 60' and 60", may be continuous, thereby surrounding discrete islands of the other subset, respectively. The framework 86 can comprise a cured polymeric photosensitive resin or other curable resins.

The texture of the framework 86 defines a predetermined pattern, which imparts a like pattern onto the paper web 32 of the present invention. The pattern for the framework 86 can be an essentially continuous network, a semi-continuous network, or can comprise discrete islands of raised elements 60. By way of example only, continuous patterns are provided in US Patent No. 4,528,239, issued July 9, 1985 to Trokhan; separate examples of both continuous and discrete patterns for imprinting fabrics (believed to be applicable to deflection members in general) are found in US Pat. No. 4,514,345, issued Apr. 30, 1985 to Johnson et al.; and examples of semi-continuous patterns are provided in US Patent No. 5,714,041, issued Feb. 3, 1998 to Ayers et al.

If an essentially continuous network pattern is selected for the framework 86, the deflection conduits 62 will be discrete blind holes extending partway between the first surface 130 and the second surface 132 of the deflection member 36. The essentially continuous network 86 surrounds and defines deflection conduits 62.

The second surface of the deflection member 36 is the machine contacting surface, which may be made with a backside network having passageways therein which are distinct from the deflection conduits 62. The passageways provide irregularities in the texture of the backside of the second surface of the deflection member 36. The passageways allow for air leakage in the X-Y plane of the deflection member 36, which leakage does not necessarily flow in the z-direction through the deflection conduits 62.

The second primary component of the deflection member 36 according to the present invention is the reinforcing structure 84. The reinforcing structure 84, like the framework 86, has a first or paper facing side and a second or machine facing surface opposite the paper 32 facing surface. The reinforcing structure 84 is primarily disposed

between the opposed surfaces of the deflection member 36 and may have a surface coincident the backside of the deflection member 36. The reinforcing structure 84 provides support for the framework 86. If one does not wish to use a woven fabric 64 for the reinforcing structure 84, a nonwoven element, screen, net, or a plate having a plurality
5 of holes therethrough may provide adequate strength and support for the framework 86.

FIG. 8 depicts a cross-section of a deflection member 36 similar to that of FIG. 7 but rendered liquid-pervious with openings 96 in the framework 86 and particularly in the lower, second subset of raised elements 60". The shape of the openings 96 may be cylindrical, or may taper to be narrower toward the web contacting side (as shown) or
10 away therefrom. The openings 96 may be uniform throughout the deflection member 36 or may have a variety of sizes and shapes. The openings may be discrete or continuous.

In FIG. 8, the deflection conduit 62 is primarily defined by the sides of the first subset of raised elements 60' and the upper surface of the second subset of raised elements 60" (depicted facing toward the bottom of the diagram in FIG. 8), though the
15 aperture 96 is also part of the deflection conduit 62. Thus, the deflection conduit 62 comprises an upper portion 65 with outwardly slanted walls and a narrower lower portion 67 with inwardly slanted walls (the nature of the slant is considered while traversing from the top, web-contacting side of the raised elements toward the base fabric). The deflection conduit 62 can also be characterized by having an upper portion 65 with a first
20 width (e.g., a mean width) and a lower portion 67 having a second width, with a step change in width occurring between the two portions 65, 67. The deflection conduit 62 can also be characterized by having an upper portion 65 with a first width (e.g., a mean width) and a lower portion 67 having a second width, the first width being greater than the
25 second width by about 30% or greater, more specifically about 50% or greater, more specifically still about 100% or greater, and most specifically about 200% or greater, with exemplary ranges including from about 80% to about 200%, or from about 150% to about 300%, or from about 250% to about 400%.

FIGS. 9A and 9B depict a top view and a cross-sectional view, respectively, of a liquid pervious deflection member 36 substantially similar in geometry to that disclosed in
30 US Patent No. 5,935,381, "Differential Density Cellulosic Structure and Process for Making Same," issued Aug. 10, 1999 to Trokhan et al., herein incorporated by reference (see FIG. 2 and FIG. 2A therein). Though similar in geometry to the aforementioned structure of Trokahn et al., the deflection member 36 of FIGS. 9A and 9B can comprise novel materials and construction methods as described herein, including elastomeric

components, a heterogeneous assembly of two or more materials of differing properties in the raised elements, and resins cured without actinic radiation.

The deflection member 36 depicted here comprises a continuous network of raised elements 60 forming a web densifying surface 61, and comprises a repeating pattern of discrete deflection conduits 62. (Alternatively, the raised elements 60 could be discrete elements surrounded by a continuous grid of deflection conduits 62, or could comprise both a continuous pattern and discrete elements, such as a first pattern resembling an interconnected rectilinear grid and a second pattern of isolated geometric shapes, such as a flower or star, disposed within the parallelograms formed by the rectilinear grid.) The network of raised elements 60 comprises a cured resin which is held in place by a woven reinforcing structure 84.

FIG. 9B depicts a cross-section of the deflection member 36 of FIG. 9A taken along the line 9B -- 9B, shown here in association with a paper web 32. The web 32 is pressed between opposing press surfaces 37, 38, which can be provided by opposing rolls, pressurized metal bands, flat platens which compress and retract to process successive segments of the web 36 in a batch-like manner, and so forth, with the presence of compressive pressure applied in the z-direction shown by the arrows P. While being pressed, the web 32 is in contact with a deformable carrier fabric 34 and the deflection member 36, which in turn is backed by the deformable backing fabric 56. The web 32 as it is pressed comprises a relatively high density region 80 associated with the web densifying surface 61 of the deflection member 36, and a relatively low density region 76 corresponding to the dome-like protrusions 68 formed in the deflection conduits 62. Depending on whether the raised elements 60 are part of a continuous grid or are discrete elements, the protrusions 68 can be discrete domes or an interconnected network of low density regions 76. One skilled in the art will understand that any given fiber may (and in many cases will) be partly in both the high density region 80 and the low density region 76. Portions of the deformable carrier fabric 34 are shown in FIG. 9B deforming as local mounds 66 into a portion of the deflection conduits 62, helping to deform the web 34 to impart a more three-dimensional topography.

FIG. 10 depicts a perspective view of a portion of a deflection member 36 comprising a base fabric 64 joined to raised elements 60 having an asymmetrical shape. Here the raised elements 60 are depicted as repeating parallel bands or ribs, a semicontinuous embodiment, which may be oriented in either the machine or cross directions. Deflection members 36 comprising a woven base fabric 64 having raised elements 60 in the form of polymeric ribs of one or more heights in a pattern such as

parallel bands or an interconnected grid are within the scope of the present invention. The ribs can be asymmetrical and/or composed of one or more dissimilar materials and/or comprise an elastomer.

FIG. 11 depicts a perspective view of a portion of a deflection member 36 in which the raised element 60 as depicted can be a repeating unit cell or a portion of a repeating unit cell, in which the profile viewed in either the machine direction or cross direction will tend to be asymmetrical. The raised element 60 in FIG. 11 could be one half of the repeating unit cell of the deflection member 36 of FIG. 9A, modified to have cross-sectional asymmetry. Such asymmetry can be produced by asymmetrical application of light in a photocuring step, or by asymmetrical application of other means such as mechanical tooling, rapid prototyping, stereolithography and the like.

FIG. 12 depicts an embodiment in which the web 32 traveling in the machine direction 19 is pressed against the deflection member 36 between a deformable carrier fabric 34 and a deformable backing fabric 56 in a compression nip 35 formed by a shoe press 120 having an upper press roll 54 and a shoe 122. A belt 124 rides over the shoe 122 with a layer of lubricant (not shown) at the interface 126 between the belt 124 and the shoe 122 to reduce friction. The belt 124 is guided by rolls 132. A hydraulic pressure source 136 applied pressure to bias the shoe 122 toward the upper press roll 54. The hydraulic pressure source 136 can provide a varying force in the cross-direction to compensate for variability in the crown of the upper press roll 54 or in the other components of the nip 35. The web 32 resides on the deformable carrier fabric 34 prior to entering the nip 35, whereafter it resides on the deflection member 36. The upper press roll 54 may be a suction roll to enhance transfer to the deflection member 36. The belt 124 may be textured and/or deformable to further enhance the texture provided to the web in the nip 35. Texturing may be provided by laser engraving, ablation, abrasion, stamping, thermal molding, and the like. The belt 134 may be provided with blind holes or grooves. It may comprise one or more layers of elastomeric materials capable of deforming when pressed. It may further comprise reinforcement fabrics, fibers, or wires.

The shoe 122 may be configured to provide a nip having a length of 10 cm or greater (i.e, the machine-direction extent of the zone in which pressure is applied to the web by the shoe press 120 is at least 10 cm in length), more specifically 20 cm or greater, and most specifically 30 cm or greater. The pressure profile in the machine direction may be any profile known in the art, such as one of:

- a rapid ascent to a peak pressure, followed by a gradual decline in pressure, such that the maximum pressure occurs before the middle of the nip 35;

- a gradual ascent to a peak pressure, followed by a rapid decline in pressure, such that the maximum pressure occurs after the middle of the nip 35;
- a substantially symmetrical profile having a maximum pressure at the middle of the nip 35;
- 5 • a profile having a first local maximum before the middle of the nip and a second local maximum before or after the middle of the nip 35;
- a substantially linear profile apart from a rapid rise and rapid descent at the beginning and end of the nip 35, respectively;
- a profile represented by a quadratic equation;
- 10 • and the like.

The Deflection Member: Production and Photocuring

The deflection member comprises raised elements having a web densifying surface (also known as the web imprinting surface for use in imprinting operations) and a deflection conduit portion into which a wet web can be deformed to form structures such as domes dispersed between high density regions of a web that were pressed against the raised elements. Deflection members can be any one of several classes, including fabrics primarily comprising woven webs; fabrics comprising a woven or nonwoven foraminous base with resin elements added to the base; materials with elevated structures such as nonwoven webs, sintered materials, films, or foam elements, the elevated structures residing on a base such as a woven fabric; and fabrics comprised of one of more layers of porous film or sheets that have not been woven but have been provided with holes or apertures.

Deflection members can be formed from a variety of techniques known in the art, including patterned photocuring or radiation curing of polymer resins after application of the resin to a base fabric, laser drilling of a material to form a stand-alone fabric or a layer for a fabric having a reinforcing base fabric, rapid prototyping methods (including selective laser sintering, stereolithography, and room temperature vulcanization molding) with or without a reinforcing base fabric in place, molding, and so forth.

The texture of the web-contacting side of the deflection member can be imparted to a paper web by imprinting, pressing, or by other means of applying a force to the paper web as it is in contact with the deflection member. When the sheet is pressed against the deflection member with a sufficiently high force, the web will receive a texture from the interaction of the web with the raised elements and the deflection conduits, and will have differential density imparted to it. The raised elements can have a depth in the z-direction

relative to the upper surface of the base fabric of at least about 30 micrometers, more specifically at least about 100 micrometers, more specifically still at least about 200 micrometers, and still more specifically at least about 500 micrometers. A suitable range for producing an absorbent, thick, soft, aesthetically pleasing tissue paper is from about
5 300 to 1000 micrometers (0.3 mm to 1 mm), or, for more highly texture webs, from about 600 to 3000 micrometers (0.6 mm to 3 mm).

The deflection member can be made according to any of the following: US Pat. No. 4,529,480, issued July 16, 1985 to Trokhan; US Pat. No. 4,514,345, issued Apr. 30, 1985 to Johnson et al.; US Pat. No. 4,528,239, issued Jul. 9, 1985 to Trokhan; US Pat.
10 No. 5,098,522, issued Mar. 24, 1992; US Pat. No. 5,260,171, issued Nov. 9, 1993 to Smurkoski et al.; US Pat. No. 5,275,700, issued Jan. 4, 1994 to Trokhan; US Pat. No. 5,328,565, issued Jul. 12, 1994 to Rasch et al.; US Pat. No. 5,334,289, issued Aug. 2, 1994 to Trokhan et al. ; US Pat. No. 5,431,786, issued July 11, 1995 to Rasch et al.; US Pat. No. 5,496,624, issued Mar. 5, 1996 to Stelljes, Jr. et al.; US Pat. No. 5,500,277,
15 issued Mar. 19, 1996 to Trokhan et al.; US Pat. No. 5,514,523, issued May 7, 1996 to Trokhan et al.; US Pat. No. 5,554,467, issued Sep. 10, 1996, to Trokhan et al.; US Pat. No. 5,566,724, issued Oct. 22, 1996 to Trokhan et al.; US Pat. No. 5,624,790, issued Apr. 29, 1997 to Trokhan et al.; US Patent Nos. 6,010,598, issued Jan. 4, 2000 to Boutilier et al.; and US Pat. No. 5,628,876, issued May 13, 1997 to Ayers et al., the disclosures of
20 which are incorporated herein by reference.

The raised elements can be applied to a reinforcing structure as taught by US Pat. No. 5,556,509, issued Sep. 17, 1996 to Trokhan et al.; US Pat. No. 5,580,423, issued Dec. 3, 1996 to Ampulski et al.; US Pat. No. 5,609,725, issued Mar. 11, 1997 to Phan; US Pat. No. 5,629,052 issued May 13, 1997 to Trokhan et al.; US Pat. No. 5,637,194, issued
25 Jun. 10, 1997 to Ampulski et al. and US Pat. No. 5,674,663, issued Oct. 7, 1997 to McFarland et al., the disclosures of which are incorporated herein by reference.

A suitable deflection member according to present invention may be made by utilizing a photosensitive resin as described in the above-referenced patents. However, for one useful embodiment described below, several deviations from the prior art
30 manufacturing processes are set forth below.

In one embodiment, liquid photosensitive resin is provided. Any suitable resin can be used, including acrylates, which historically have been widely accepted in photocuring systems, primarily because of the wide range of suitable initiators that can be successfully applied. One example of a liquid photosensitive resin is Merigraph L055 available from
35 MacDermid Imaging Technology, Inc. of Wilmington, Del. Antioxidant compounds may be

present, as described in US Patent Nos. 6,010,598, issued to Boutilier et al. on Jan. 4, 2000; 5,059,283 issued to Hood et al. on Oct. 22, 1991 and 5,0573,235 issued to Trokhan on Dec. 17, 1991, all of which in pertinent part are incorporated herein by reference.

Suitable liquid photosensitive resins can further include polyimides capable of final
5 curing at room temperature. *NASA Tech Briefs*, March 1999, p. 52-53 describes room-temperature UV curing of polyimides with a new Diels-Alder route involving photoenolization of methylphenyl ketones. Prior art methods for curing polyimides required temperatures above 200°C. Such polyimides can also be adapted for UV-cured fabrics for use in the present invention.

10 In one embodiment, the resin is disposed on a backing surface such as a large roll. A mask having transparent and opaque regions is juxtaposed with the photosensitive resin. Actinic radiation such as ultraviolet light is passed through the transparent regions of the mask. Alternatively, visible light is passed through the mask if visible light photoinitiators are used, or an electron beam can be passed through the mask for
15 electron beam curing of the resin, or other radiation sources suited for curing the resin are passed through the mask. The radiation passing through the transparent regions of the mask cures the resin therebeneath to yield an impermeable region in the deflection member. After curing, described more fully below, uncured resin is removed by washing, solvent extraction, or other means, leaving a cured web with a three-dimensional
20 structure. UV photocuring techniques and equipment therefore are well known and principles therefor are taught in previously cited patents. By way of specific equipment, UV curing can be achieved using devices such as those produced by UV Process Supply, Inc., Chicago, IL, as described in their 1998 catalog (UVPS-CA98). General principles of radiation curing of polymers are discussed in *Radiation Curing in Polymer Science and*
25 *Technology: Fundamentals and Methods*, ed. by J.P. Fouassier and J.F. Rabek, Vol. 1, Elsevier Applied Science, 1993 (ISBN: 1851669299), and *Radiation Curing in Polymer Science and Technology: Photoinitiating Systems*, ed. by J.P. Fouassier and J.F. Rabek, Vol. 2, Elsevier Applied Science, 1993 (ISBN: 1851669337).

Fabrics formed by adding resin elements to a woven base can be formed in a
30 variety of ways (most of which can also be applied to the addition of resin elements to a nonwoven base), including application of a resin over much or all of a woven base followed by selective curing of particular regions, such as UV curing through a stencil or mask to selected portions of the resin only, followed by removal of uncured resin through application of a solvent or other means. Alternatively, resins can be added directly in a
35 pattern without the need for photocuring if the resin is self-curing (i.e., an epoxy resin after

mixing with an initiator) or is cured or solidified by other means, such as thermal curing or cooling of a molten thermoplastic. For example, a woven base fabric could be held against a mold for receiving a resin in liquid state which hardens in contact with the base fabric, with a texture imparted by the substrate which held the resin against the fabric.

5 For photocuring of resin, radiation can be bombarded on the deflection member both in the direction perpendicular to the plane of the deflection member and in off-axis, i.e., non-perpendicular directions. By providing off-axis radiation, a portion of the resin registered with, but beneath, the opaque regions of the mask is cured, along with the resin registered with the transparent regions of the mask. However, such curing beneath
10 the opaque regions occurs at a finite depth below the mask. The regions of the resin immediately beneath the opaque regions of the mask may not cure, due to the incident angle of the radiation. The off-axis, i.e., non-perpendicular, radiation should be sufficient to cure the resin throughout the X-Y plane of the deflection member. For one embodiment for producing a fabric with an asymmetrical profile in the raised elements, actinic radiation
15 is applied from only one direction varying from the perpendicular at an angle of 10 degrees or more; more specifically 14 degrees or more; more specifically still about 20 degrees or more; and most specifically still from about 25 degrees to about 45 degrees.

In the manufacture of deflection members having asymmetrical structures or other structures within the scope of the present invention, radiation can also be applied from
20 two or more angles to photocure or radiatively cure a resin, as well as to produce complex structures with laser drilling or radiation-based rapid-prototyping methods.

To achieve some aspects of the present invention, it can be desirable to impart certain mechanical and geometrical properties to the deflection member. Many such properties can be obtained with known UV-cured imprinting fabrics and other fabrics
25 known in the art, but suitable fabrics can also be obtained through the application of technologies other than UV-curing such as visible light photocuring, including, for example, three-component photoinitiator systems suitable for use with visible laser light optical systems. Visible light photocuring eliminates some of the safety concerns associated with ultraviolet processing and also has the potential to offer reduced cost.

30 In another embodiment, a fabric is prepared with a first resin and a second resin, separately curable by visible and UV light, respectively, wherein curing can be performed in successive steps or simultaneously to provide two or more patterns of cured materials having different material properties. For example, treatment with visible light could be conducted first, followed by further treatment with UV light. In general, photocured
35 deflection members need not be produced with actinic radiation or ultraviolet light in

particular, but can also be produced with non-actinic visible or infrared light, or by radiation from non-UV sources as electron beams or gamma rays applied through a suitable mask to shield the curing radiation from regions of the resin that are to remain uncured and readily removable.

5 Curing via a photobleaching process can also be useful for production of relatively thick cured resin elements. In photobleaching, the upper layers of a resin system become more transparent or translucent after being cured, allowing the light to penetrate further into uncured resin, which then bleaches as it is cured and allows light to penetrate still deeper until the full thickness of the resin has been cured.

10 Visible light photocuring can be achieved with the three component photoinitiator systems described by Kathryn Sirovatka Padon and Alec B. Scranton of Michigan State University in "Recent Advances in Three Component Photoinitiator Systems," *Recent Research Development in Polymer Science*, Vol. 3, pp. 369-385, 1999.

According to Padon and Scranton, typical UV photocuring methods rely on
15 photoscission excited by the absorption of ultraviolet light, which brings the photoinitiator into a triplet state wherein the bond alpha to the carbonyl group is cleaved, yielding a benzoyl radical and a second fragment. Examples of such photoinitiators include benzoin ethers, dialkoxyacetophenones, hydroxy alkyl ketones, benzoyl oxime esters, amino ketones, and morpholino ketones, all of which absorb via the benzoyl chromophore in the
20 spectrum range of about 150 to 400 nm. Gamma cleavage may also occur for some alpha-cleavable photoinitiators.

The use of more than one component is required for some photoinitiators. Bimolecular reactions involving hydrogen abstraction are involved in one class of known photoinitiators, for example, including the benzophenone and thioxanthone families.
25 Bimolecular reactions involving electron transfer is somewhat more common. In this system, a photoinitiator in a triplet state forms an exciplex with an electron donor, typically an amine, according to Padon and Scranton. When the electron is transferred, followed by proton transfer from the amine to the photoinitiator, neutral amine and ketyl radicals are formed. The electron transfer mechanism can occur for benzophenones,
30 thioxanthenes, benzil derivatives, ketocoumarins, xanthenes, and camphorquinone.

For visible light photoinitiation, many dyes and other compounds are known for which bimolecular mechanisms occur involving electron transfer initiators. Iron-arene complexes and titanocene derivatives are also known for visible light systems, and even some alpha-cleavable systems are known with absorption maxima beyond 300 nm.

A recent development has been three-component systems for visible light photoinitiation. These systems comprise a dye or other light absorbing compound, an electron donor which can be an amine, and third component that is typically an iodonium salt which can accept an electron. Typical electron donors include N-

5 methyl-diethanolamine, N-phenylglycine, sodium toluene sulfinate, N,N-dimethylacetamide, 4,4-dimethoxybiphenyl, N,N-dimethylurea, triethylamine, and ferrocene. Diphenyliodonium chloride is the most commonly used third component, but other iodonium salts can be used, including those with less nucleophilic counterions such as AsF_6^- , PF_6^- , SbF_6^- , BF_4^- , Br^- , I^- , $\text{C}_6\text{H}_5\text{SO}_3^-$, and SbF_5OH^- . Substituted iodonium cations can also be used. Other

10 specific known third components listed by Padon and Scranton include 2,2,2-tribromoacetophenone, and iron arene complexes such as that described by Fouassier et al, *Polymer*, Vol. 38, 1997, p. 1415. Such three-component systems require less energy to be activated than typical two-component systems. In many three-component systems, the dye undergoes photobleaching, allowing light to pass deeper into the resin as curing

15 occurs, enabling the curing of relatively thick resin deposits. See, for example, V. Narayanan and A.B. Scranton, *Trends in Polymer Science*, Vol. 5, 1997, p. 415. One useful system is disclosed in US Pat. No. 5,229,253, issued March 8, 1991 to R. Zertani, herein incorporated by reference. Zertani discloses a photopolymerizable mixture comprising a polymeric binder, a compound which is polymerizable by free radicals and at

20 least one polymerizable group and a photoreducible dye plus a dicyclopentadienyl bis(2,4,6-trifluorophenyl)-titanium or -zirconium as the photoinitiator. The mixture is said to be suitable for producing printing plates and photoresists and is distinguished by particularly high photosensitivity in the visible region of the spectrum. It can be imaged, for example, with laser radiation in the visible region. Another three-component system is

25 disclosed in US Pat. No. 4,735,632, issued to J.D. Oxman et al., April 5, 1988, herein incorporated by reference. Photopolymerization of an acrylic monomer (phenoxy diethyleneglycol acrylate) using an argon ion laser (visible light with a wavelength of 488 nm) was made possible with Kodak Reagent 14875, a ketocoumarin compound (3,3'-carbonyl-bis-7-diethylaminocoumarin) in the presence of an amine (e.g., N-phenylglycine)

30 and an onium salt (e.g., diphenyl iodonium chloride), according to J.P. Fouassier et al., "A New Three-component System in Visible Light Photo-induced Polymerization," *J. Imaging Science and Technology*, Vol. 37, No. 2, March/April 1993, pp. 208-210.

M. Kawabata and Y. Takimoto disclose the use of an argon ion laser beam to cure a three-component system with visible light in "Photoinitiation Systems Comprises of Dyes and Radical Precursors," *Journal of Photopolymer Science and Technology*, Vol. 1, No. 2,

35

1988, pp. 222-227. The system comprises a dye, diphenyliodonium chloride, and N-phenylglycine. The photoinitiators were dissolved in a solvent and mixed with a solution of an acrylic polymer and a polyfunctional acrylic monomer. The weight ratio of the polymer, monomer, and dye was 100:100:6. An argon ion laser scanning system was used for
5 image formation. The wavelength was 488 nm, the beam diameter 25 micrometers, and the laser power was 0.1 W, 0.2 W, or 0.3 W. Application of the laser light was found to cause the polymer solution to gel. By extension, a similar system could be used to cure a resin on a reinforcement member such as a woven fabric. Application of laser light in specific patterns, as is well known in the art, could be used to provide patterns and
10 textures in a papermaking fabric that were previously unknown or difficult to achieve.

Textured polymeric fabrics can also be formed by a variety of methods for assembling three-dimensional structures in the art of rapid prototyping, including selective laser sintering, stereolithography, and RTV (room temperature vulcanization) molding, all of which are services available from Accelerated Technologies, Inc. (Austin, Texas). A
15 related method is Fuse Deposition Modeling, in which a molten stream of a polymer is selectively laid down in thin layers according to a predetermined pattern to build a complex three-dimensional structure. Fuse Deposition Modeling is offered by Conceptual Reality L.L.C. (Walled Lake, Michigan). The material made in this manner may be used as is, or after joining to a reinforcing base layer. Rapid prototyping may be done with a
20 reinforcing fabric or mesh already present, as well.

The deflection member need not be made by photocuring or by patterned curing of resin, but can be made in a wide variety of methods known in the art. Machine tooling of polymer belts can be applied to engrave specific patterns into a belt to create a deflection member or a textured shoe belt. Thus, metal or hardened polymeric tools can act directly
25 on an initially flat surface to impart engraving marks. Likewise, an initially flat polymeric belt can be rendered textured by thermal molding against a textured surface, embossing between one or more textured surfaces, laser engraving, ablation, ultrasonic drilling or molding, and the like. The deflection member can also be a drilled nonwoven web such as the web of Hans Albert disclosed in US Pat. No. 4,541,895, issued Sept. 17, 1985
30 previously incorporated by reference. One source for laser drilling to provide textured deflection members is Laserworks, a division of Stencil Aire, Inc., (Green Lake, Wisconsin). A deflection member can also be formed by molding or casting to have a texture, which may subsequently be modified by tooling, engraving, or other methods to further enhance the texture.

Other Embodiments of the Deflection Member

The deflection member may be made in several other embodiments. For example, it is not necessary that the deflection member utilize a reinforcing structure. If desired, the deflection member may be made of the photosensitive resin, described above, cast on a surface not having a reinforcing structure. Thus, a deflection member can comprise a single material cast to form a network of raised elements with deflection conduits therebetween, such as apertures that render the deflection member liquid permeable, or sealed depressed regions that provide deflection conduits in an impermeable deflection member.

10 The deflection members described herein can be substantially impermeable to water. By "substantially impermeable," it is meant that the deflection member transmits no water through capillaries having any one dimension of 50 microns or greater. In one embodiment, the deflection member is substantially impervious to liquid flow but pervious to gas flow. For example, a hydrophobic web with sufficiently small pores can substantially hinder the flow of water through the web while permitting gas transport. Thus, the web can have less than 5% open area and can have an average pore size less than 20 microns, more specifically less than 10 microns, and most specifically from about 1 to 30 microns.

Polyurethane resins and foams have also successfully been used to render belts impermeable, as illustrated by the commercially available Trans-belt, an impermeable belt manufactured by Albany International of Albany, N.Y. Alternatively, rubber and silicone coatings may be utilized to render the belt impervious. The material which renders the belt impervious may be applied by any known means such as printing, spraying, blade coating, other coating technologies, or impregnating. Impregnating can be done by immersing the belt in a bath of the substance or by forcing the substance into the voids of the belt at an elevated hydraulic pressure (i.e., a pressure gradient drives the substance into the belt).

Suitably, the deflection member according to the present invention may be made with a texture comprising semi-continuous, continuous or discrete patterns or combinations thereof in the X-Y plane of the belt. In producing an impermeable deflection member, a permeable papermaking belt having outwardly extending raised elements and openings therebetween can be rendered impermeable. For example, a permeable deflection member according to other embodiments of the present invention can be used, as well as the belt disclosed in US Pat. No. 4,239,065, issued to Trokhan, or a Spectra Membrane® fabric sold by Voith Fabrics (Raleigh, NC). The belt is immersed in liquid resin to a depth which does not immerse the outwardly extending raised elements of the

belt. The resin is cured as described above rendering the belt impermeable, but leaving the pattern of raised elements so that the impermeable deflection member retains its original texture. More generally, the openings between the raised elements are sealed with cured resin, a film, or other materials while preserving at least a portion of the texture
5 of the web contacting surface of the fabric, such that deflection conduits are defined between the raised elements.

In another embodiment, after a belt has been rendered impermeable by any means or material, additional texture may be imparted to form a deflection member by casting photosensitive resin thereon, as described above. Alternatively, the texture may
10 be provided by stitching, or selectively removing material from the belt. The texture, without regard to how it is imparted or the belt is made, may comprise any desired X-Y pattern. The texture may be discontinuous, semi-continuous, or continuous.

One embodiment utilizes an impermeable conventional felt. The impermeable felt has material applied to the back side which renders the felt impermeable. Then, the top
15 side of the felt is provided with knuckles by stitching the knuckles into the sheet side thereof. In this manner, an impermeable felt having knuckles which imparts texture and also absorbs water from the paper is provided. As used herein, knuckles refer to a pattern raised above the plane of the sheet side of the deflection member and extending outwardly therefrom.

In one embodiment, the deflection member comprises two or more sets of
20 deformation elements (e.g., the UV-cured resin elements on a woven base fabric) residing in a common plane or multiple planes wherein the elastic properties of the deformation elements differ substantially. The domes formed by deformation of a web into the deflection conduits between or in the deformation elements will therefore differ in
25 properties (height, thickness, strength, etc.) because of the differing mechanical response of the deformation elements. For example, two UV-curable resins could be applied in discrete zones on a fabric, such as in two separate steps, with one resin curing to be substantially rigid and the other curing to a substantially elastomeric state or substantially deformable state. Alternatively, a visible-light resin could be cured in a pattern applied by
30 a computer-controlled laser source, while a second UV-curable resin was cured by traditional methods, producing a fabric with two patterns of cured resins cured by visible-light and UV-light, respectively. The two patterns may have different heights, different compressive properties (e.g., differing elastic moduli), or different thermal conductivities. Likewise, the support structures for the deformation elements may have different material
35 properties to allow some regions of the deflection member to deform more than others

when in a nip. With two or more regions of the deflection member having different material properties, pressing the deflection member against a web in a nip can yield one set of depressions or elevated regions in the web having greater depth and clarity and different material properties than the set of depressions or sheet markings formed by deformation elements having a second set of material properties. The combination of two or more regions of deflection elements or support elements on the deflection member having different material properties (compressibility or height, for example) with a press nip optionally having differential velocity contact opens the possibility for a wide range of material properties and textures that can be imparted to tissue webs.

10 Papermaking belts or fabrics useful for the method of Ampulski that could be modified to have two or more resin-based or thermoplastic deformation elements include those of US Pat. No. 5,098,522, "Papermaking Belt and Method of Making the Same Using a Textured Casting Surface," issued to J.A. Smurkoski et al., March 24, 1992; US Patent No. 5,275,700, issued Jan. 4, 1994 to Trokhan; US Pat. No. 4,529,480, issued to P.D. Trokhan, July 16, 1985; US Pat. No. 4,637,859, issued to P.D. Trokhan, Jan. 20, 15 1987; US Pat. No. 4,514,345, issued to Johnson et al., Apr. 30, 1985, and the like. Voith's Ribbed Spectra® fabrics and other Voith fabrics can also be used, including those disclosed in US Pat. No. 5,508,095, "Papermachine Clothing," issued to A. Allum et al., April. 16, 1996, or other fabrics with extruded elevated thermoplastic or resin members adhered to a woven base fabric. Other fabric concepts can also be used, including the 20 nonwoven molding substrates of Lindsay and Burazin in US Patent No. 6,080,691, issued June 27, 2000, previously incorporated by reference.

In an alternative embodiment, the deflection member is joined to the deformable backing fabric, yielding a composite deflection member. For example, a papermakers felt 25 can be impregnated with a photocurable resin on the upper surface, which is then cured in a pattern to form cured raised elements and deflection conduits where the resin was not cured but subsequently removed, as by washing with a solvent. Principles for production of composite imprinting elements are disclosed in US Patent No. 5,817,377, "Method of Applying a Curable Resin to a Substrate for Use in Papermaking," issued Oct. 6, 1998 to Trokhan et al., and US Patent No. 5,871,887, "Web Patterning Apparatus Comprising a 30 Felt Layer and a Photosensitive Resin Layer," issued Feb. 16, 1999 to Trokhan et al., both of which are herein incorporated by reference.

The texture from the deflection member can interact effectively with the texture of yet another web-contacting element to produce a texture more complex or beneficial to 35 material properties than could be obtained with a single fabric. The other web-contacting

element with whose texture the texture of the deflection member can interact could be the deformable carrier fabric or a subsequent through-drying or imprinting fabric or a textured roll such as a drying drum or an embossing roll. In one embodiment, however, the other web-contacting element is not an embossing roll, and more specifically is an element that
5 imparts a degree of texture to the web before it has been dried above about 70% solids, more specifically above about 80% solids, and most specifically before it has reached final dryness (typically over 90% such as about 95-98% dryness).

The deflection member of the present invention may also comprise two or more reinforcing layers (i.e., the base fabric may comprise two or more layers of material, such
10 as separately woven or interwoven layers), wherein at least one subset of the raised elements join at least two of the two or more reinforcing layers together. Such embodiments may follow the principles and structures disclosed by Stelljes, Jr. et al. in US Patent No. 5,496,624, "Multiple Layer Papermaking Belt Providing Improved Fiber Support for Cellulosic Fibrous Structures, and Cellulosic Fibrous Structures Produced
15 Thereby," issued Mar. 5, 1996, herein incorporated by reference.

The deflection member may further comprise a fine texture superimposed on the individual raised elements. For example, ridges, microprotrusions, and indentations can be placed on the surfaces of the raised elements. In particular, the raised elements can also comprise "synclines" as defined in US Patent No. 6,117,270, issued Sept. 12, 2000
20 to Trokhan, herein incorporated by reference. In general, a syncline is a blind hole, fissure, chasm, or notch in the framework of raised elements, in contrast to a deflection conduit which provides an open hole exposing the underlying base fabric. Paper that has been molded or imprinted against a fabric comprising synclines can be said to have "syncline marks." In addition to the holes, fissures, chasms, or notches of US Patent No.
25 6,117,270, the deflection members of the present invention can be modified to have "anti-synclines," which are ridges, bumps, and protrusions on the framework of raised elements that can impart "negative" versions of the small-scale texture that would have been imparted by similarly patterned synclines (imparting indentations to the paper in contrast to the raised bumps that synclines would impart). Any of the syncline patterns or principles
30 for formation of syncline patterns described in US Patent No. 6,117,270 can generally be adapted for anti-synclines as well. In one embodiment, the deflection member comprises a first pattern of synclines and a second pattern of anti-synclines. The characteristic depth of an anti-syncline can be equal to, greater than, or smaller than suitable depths for synclines, and when both synclines and anti-synclines are present, the characteristic

depths can be the same or substantially different. In one embodiment, a tissue web can have syncline marks and anti-syncline marks.

The deflection member can be treated in a variety of ways to improve surface properties, frictional properties, wear resistance, and the like. Application of silicone compounds or other release agents to the surface of the deflection member can be done. 5 The deflection member can also be treated with plasma, corona discharge, or chemical means to provide desired functional groups on the surface.

Other Embodiments for Tissue

Many other treatments and processes known in the art can be applied to the tissue web of the present invention. For example, once the web has been transferred to the deflection member after the compressive nip, the web may be further molded against the deflection member by application of a flexible sheet of material on the exposed surface of the web (thus sandwiching the web between the deflection member and the flexible sheet of material), wherein the flexible sheet has a lower air permeability than the deflection 15 member, followed by application of differential air pressure across the combined flexible sheet, paper web, and deflection member, such that the highest air pressure is against the flexible sheet and the lowest air pressure is against the deflection member. In this manner, the air pressure gradient will press against the less permeable flexible sheet and cause it to urge the web to further conform to the topography of the deflection member, 20 thus improving the molding of the web. The flexible sheet can be elastic in the machine direction or in both the machine direction and cross direction, to better conform to the topography of the deflection member under differential air pressure. The molding of a web by application of elevated air pressure against the flexible sheet of material is more fully described in US Pat. No. 5,893,965, issued April 13, 1999 to Trokhan and Vitenberg, 25 previously incorporated by reference. One useful flexible sheet for such purposes is the EXXTRAFLEX® film type "EXX 7 A-1" (having thickness of about 1.5 mils) available from Exxon Chemical America's Film Division's plant, Lake Zurich, Ill., Exxon Corporation (New Jersey Corporation), Flemington, N.J. 08822. Further, US Pat. No. 5,518,801 issued May 21, 1996 to Chappell et al. and incorporated by reference herein, discloses a web 30 material that exhibits an elastic-like behavior along at least one axis when subjected to an applied and subsequently released elongation. The flexible sheet can be a deformable non-resilient sheet loosely maintained in a proximate relation to the deflection member and the web residing thereon such that when elevated air pressure is applied to the

flexible sheet, the sheet is capable of approximating the geometry of the deflection conduits of the belt deflection member.

Elevated portions of the web on either side of the web (tops of domes or the pattern densified network) can be selectively treated with chemical agents such as starch, surfactants, elastomers, sizing material, waxes, hydrophobic matter, superabsorbent material or superabsorbent precursors, as described in WO 95/13780 by D. Van Phan and P.D. Trokhan, published May 26, 1995, or according to the various surface treatments disclosed in US Pat. No. 5,431,643, issued to Ouellette et al., July 11, 1995, and the like to obtain improved physical properties or other properties in the product.

10 Means such as gravure printing, size press coating of a liquid, and the like can be used. In one embodiment, for example, a latex emulsion or an adhesive material such as polyvinyl alcohol is selectively printed by rotogravure printing or other means onto the most elevated portions of the web. The web may then be dried, or dried and creped off a Yankee dryer, or joined to another web.

15 In other embodiments, the wet or dry web can also be impregnated with a solution, hot melt, or slurry. One useful method for impregnation of a moist web is the Hydra-Sizer® system, produced by Black Clawson Corp., Watertown, NY, as described in "New Technology to Apply Starch and Other Additives," Pulp and Paper Canada, 100(2): T42-T44 (Feb. 1999). This system consists of a die, an adjustable support structure, a catch pan, and an additive supply system. A thin curtain of descending liquid or slurry is created which contacts the moving web beneath it. Wide ranges of applied doses of the coating material are said to be achievable with good runnability. The system can also be applied to curtain coat a relatively dry web, such as a web just before or after creping.

20

The elevated regions or depressed regions so produced can be provided with absorbency aids, as disclosed in US Patent No. 5,840,403, "Multi-Elevational Tissue Paper Containing Selectively Disposed Chemical Papermaking Additive," issued Nov. 24, 1998 to Trokhan et al., the parts of which that are non-contradictory with the instant specification being herein incorporated by reference. Elevated portions of the web can also be provided with hydrophobic material to improve the dry feel of the wetted article against the skin, as disclosed in commonly owned US Patent No. 5,990,377, "Dual-Zoned Absorbent Webs," issued Nov. 23, 1999, herein incorporated by reference. For example, gravure printing of quaternary ammonium-based debonder agents or softening agents can be used at a sufficiently low nip pressure to restrict absorption of the agent so applied to primarily the uppermost portions of the textured web surface.

25

30

Any additives, pigments, inks, emollients, pharmaceuticals, and the like described herein or known in the art can be applied to the web of the present invention, either uniformly or heterogeneously. When applied heterogeneously in a repeating pattern to one or both surfaces of the web, the pattern of application on one or more surfaces of the web can be registered with the topographical pattern produced by the deflection member in the web such that domes or protrusions are selectively treated or selectively untreated. However, the pattern of application need not be registered with the pattern produced by the deflection member and may either be registered with some other structural aspect of the tissue such as secondary pattern produced by a texture deformable carrier fabric or textured dryer drum, or may not be registered at all with any discernible topographical feature of the tissue that existed prior to application of the additive. In one embodiment, both sides of the web are treated with one or more additives applied in non-identical patterns. For example, one surface may be sprayed substantially uniformly with a sizing agent while the other surface may be heterogeneously treated with a lotion or emollient that is selectively deposited on the outward projection portions of the web.

The paper webs of the present invention can be used in many forms, including multilayered structures, composite assemblies, and the like. The web may also be used as a basesheet for construction of wet wipes, paper towels, and other articles. For example, the web may be impregnated with a latex and then creped. Specifically, the web may be used for single or double print-creping as described in US Patent No. 3,879,257, "Absorbent Unitary Laminate-Like Fibrous Webs and Method for Producing Them," issued Apr. 22, 1975 to Gentile et al., herein incorporated by reference. The web may also be treated with wet strength resins on one side prior to contacting a Yankee dryer, wherein the wet strength resin assists in creping and provides improved temporary wet strength to the web, as disclosed in US Patent No. 5,993,602, "Method of Applying Permanent Wet Strength Agents to Impart Temporary Wet Strength in Absorbent Tissue Structures," issued Nov. 30, 1999 to Smith et al.

In one embodiment, the paper webs of the present invention are laminated with additional plies of tissue or layers of nonwoven materials such as spunbond or meltblown webs, or other synthetic or natural materials. For example, in a cellulosic product containing two or more plies of tissue, such as bath tissue, a pair of plies such as the plies forming the opposing outer surfaces of the product may comprise any of the following: a creped and uncreped web; a calendered and uncalendered web; a web comprising hydrophobic matter or sizing agents and a more hydrophobic web; webs of two differing basis weights; webs of two differing embossment patterns; an embossed and

unembossed web; a web with high wet strength and a web with low wet strength; a web having syncline marks and a web free of syncline marks; a web with antimicrobial additives and a web free of such additives; a web with asymmetrical domes and one free of domes; a through-dried web and a web dried without use of a through-dryer; webs of
5 two different colors; an apertured web and an unapertured web; and the like. Lamination can be achieved through crimping, perf-embossing, adhesive attachment, etc. The adhesive can comprise natural materials such as starch, gum arabic, and the like, or adhesives containing natural fibers, exemplified by US Pat. No. 5,958,558, "Corrugating Adhesives Employing Tapioca Fiber," issued to J.E.T. Giesfeldt and J.R. Wallace, Sept.
10 28, 1999.

Laminates formed with the webs of the present invention can be produced by any method known in the art, including lamination with thermoplastic adhesives to a film as disclosed in US Pat. No. 5,958,178, issued Sept. 29, 1999 to P. Bartsch and H.-J. Mueller.

15 The products made from the webs of the present invention may be in roll form with or without a separate core, or may be in a substantially planar form such as a stack of facial tissues, or in any other form known in the art. Products intended for retail distribution or for sales to consumers will generally be provided in a package, typically comprising plastic (e.g., flexible film or a rigid plastic carton) or paperboard, having printed
20 indicia displaying product data and other consumer information useful for retail sales. The product may also be sold in a package coupled with other useful items such as lotions or creams for skin wellness, pharmaceutical or antimicrobial agents for topical application, diaper rash treatments, perfumes and powders, odor control agents such as liquid solutions of cyclodextrin and other additives in a spray bottle, sponges or mop heads for
25 cleaning with disposable high wet strength paper, and the like.

In another embodiment, the webs of the present invention are used to produce wet wipes such as premoistened bath tissue. For good dispersibility and good wet strength, binders that are sensitive to ion concentration can be used such that the binder provides integrity in a wetting solution that is high in ion concentration, but loses strength when
30 placed in ordinary tap water because of a lower ion strength. Examples of suitable binders and product designs are disclosed in US Patent No. 5,972,805, "Ion Sensitive Polymeric Materials," issued Oct. 26, 1999 to Pomplun et al.; US Patent No. 5,935,880, "Dispersible Nonwoven Fabric and Method of Making Same," issued Aug. 10, 1999 to Wang et al.; US Patent No. 5,384,189, "Water-Decomposable Non-Woven Fabric," issued Jan. 24, 1995
35 to Kuroda et al.; US Patent No. 5,317,063, "Water-Soluble Polymer Sensitive to Salt,"

issued May. 31, 1994 to Komatsu et al.; US Patent No. 5,312,883, "Water-Soluble Polymer Sensitive to Salt," issued May. 17, 1994 to Komatsu et al.; US Patent No. 4,164,595, "Premoistened Flushable Wiper," issued Aug. 14, 1979 to Adams et al.; and US Patent No. 4,362,781, "Flushable Premoistened Wiper," issued Dec. 7, 1982 to
5 Anderson; all of which are herein incorporated by reference. Related water dispersible binder systems include the cellulose sulfates of Varona in US Patent No. 4,419,403, "Water Dispersible Premoistened Wiper," issued Dec. 6, 1983.

US Patent No. 4,537,807, "Binder for Pre-Moistened Paper Products," issued Aug. 27, 1985 to Chan et al., and herein incorporated by reference, discloses a premoistened
10 towelette or wiper type paper product having high wet strength when stored in an acidic pH medium and during usage and lower wet strength when immersed in a neutral or alkaline pH medium for disposal in conventional sewage systems comprising a non-woven fibrous web. The nonwoven web is treated with a polymeric binder comprising a copolymer of glyoxal and polyvinyl alcohol which is said to maintain high wet strength
15 when stored for sustained periods of time in acidic pH wetting medium conventionally used for external cleansing of the human body and during usage and yet which will readily break-up during flushing. Chan et al. also teach a method of treating non-woven fibrous webs with the glyoxalated polyvinyl alcohol copolymer binder and drying prior to wetting in an acidic, e.g. boric acid medium. Such systems can be applied to the webs of the
20 present invention as well.

In a related embodiment, the web is premoistened with a lotion comprising a silicone based sulfosuccinate, as disclosed by M.F. Richards in WO 99/13860, published March 25, 1999.

After formation of the embryonic web and prior to contact with the deflection
25 member, a variety of other treatments can be applied to the web to improve processability or to add desirable properties. For example, enhanced dewatering of the embryonic web can be performed by nonthermal or thermal means to elevated the web consistency to levels such as 20% or greater, more specifically 25% or greater, more specifically still about 30% or greater, and most specifically about 40% or greater, with an exemplary
30 range of from about 37% to 50% or from 42% to about 55%. Dewatering can be substantially nonthermal, particularly fiber consistencies less than about 35%. Nonthermal dewatering means can include application of vacuum or differential gas pressure to drive liquid out, or applied capillary pressure across the web to pull liquid out. Useful methods with differential gas pressure include the use of air presses as disclosed in commonly
35 owned US Patent Applications Ser. No. 08/647,508, "Method and Apparatus for Making

Soft Tissue", filed May 14, 1996; Ser. No. 09/201100, "Apparatus and Method for Dewatering a Paper Web," filed Nov. 30, 1998, and Ser. No. 09/298250, "Air Press For Dewatering A Wet Web," filed April 23, 1999. Also relevant are the paper machine disclosed in US Patent 5,230,776 issued July 27, 1993 to I.A. Andersson et al.; the
5 capillary dewatering techniques disclosed in US Patents 5,598,643 issued February 4, 1997 and 4,556,450 issued December 3, 1985, both to S. C. Chuang et al.; and the dewatering concepts disclosed by J.D. Lindsay in "Displacement Dewatering to Maintain Bulk," *Paperi ja Puu*, 74(3): 232-242 (1992).

The webs of the present invention may be subsequently treated in any way known
10 in the art. The web may be provided with particles or pigments such as superabsorbent particles, mineral fillers, pharmaceutical substances, odor control agents, and the like, by methods such as coating with a slurry, electrostatic adhesion, adhesive attachment, by application of particles to the web or to the elevated or depressed regions of the web, including application of fine particulates by an ion blast technique as described in WO
15 00/003092, "Method for Making Paper, Assembly for Implementing the Method and Paper Product Produced by the Method," by V. Nissinen et al., published Jan. 20, 2000, and the like. The web may also be calendered, embossed, slit, rewet, moistened for use as a wet wipe, impregnated with thermoplastic material or resins, treated with hydrophobic matter, printed, apertured, perforated, converted to multiply assemblies, or converted to bath
20 tissue, facial tissue, paper towels, wipers, absorbent articles, and the like.

The tissue products of the present invention can be converted in any known tissue product suitable for consumer use. Converting can comprise calendering, embossing, slitting, printing, addition of perfume, addition of lotion or emollients or health care additives such as menthol, stacking preferably cut sheets for placement in a carton or
25 production of rolls of finished product, and final packaging of the product, including wrapping with a poly film with suitable graphics printed thereon, or incorporation into other product forms.

Layered Webs

In one embodiment, the papermaking web itself comprises multiple layers having
30 different fibers or chemical additives. The tissue of the present invention can be produced in layered form, wherein a plurality of furnishes are used to produce an embryonic paper web. This can be achieved by employing a single headbox with two or more strata, or by employing two or more headboxes depositing different furnishes in series on a single forming fabric, or by employing two or more headboxes each depositing a furnish on a

separate forming fabric to form an embryonic web followed by joining ("couching") the embryonic webs together to form a multi-layered web. The distinct furnishes may be differentiated by at least one of consistency, fiber species (e.g., eucalyptus vs. softwood, or southern pine versus northern pine), fiber length, bleaching method (e.g., peroxide
5 bleaching vs. chlorine dioxide bleaching), pulping method (e.g., kraft versus sulfite pulping, or BCTMP vs. kraft), degree of refining, pH, zeta potential, color, Canadian Standard Freeness (CSF), fines content, size distribution, synthetic fiber content (e.g., one layer having 10% polyolefin fibers or bicomponent fibers of denier less than 6), and the presence of additives such as fillers (e.g., CaCO₃, talc, zeolites, mica, kaolin, plastic
10 particles such as ground polyethylene, and the like) wet strength agents, starch, dry strength additives, antimicrobial additives, odor control agents, chelating agents, chemical debonders, quaternary ammonia compounds, viscosity modifiers (e.g., CMC, polyethylene oxide, guar gum, xanthan gum, mucilage, okra extract, and the like), silicone compounds, fluorinated polymers, optical brighteners, and the like. For example, in US Patent No.
15 5,981,044, issued Nov. 9, 1999, Phan et al. disclose the use of chemical softeners that are selectively distributed in the outer layers of the tissue, as can be practiced in the present invention.

Stratified headboxes for producing multilayered webs are described in US Pat. No. 4,445,974, issued May 1, 1984, to Stenberg; US Pat. No. 3,923,593, issued Dec. 2, 1975
20 to Verseput; US Pat. No. 3,225,074 issued to Salomon et al., and US Pat. No. 4,070,238, issued Jan. 24, 1978 to Wahren. By way of example, useful headboxes can include a four-layer Beloit (Beloit, Wisc.) Concept III headbox or a Voith Sulzer (Ravensburg, Germany) ModuleJet® headbox in multilayer mode.

Principles for stratifying the web are taught by Kearney and Wells in U.S. Pat. No.
25 4,225,382, issued Sept. 30, 1980, which discloses the use of two or more layers to form ply-separable tissue. In one embodiment, a first and second layer are provided from slurry streams differing in consistency. In another embodiment, two well-bonded layers are separated by an interior barrier layer to enhance ply separability. Dunning in U.S. Pat. No. 4,166,001, issued Aug. 28, 1979 also discloses a layered tissue with strength agents in
30 the outer layers of the web with debonders in the inner layer. Taking a different approach aimed at improving tactile properties, Carstens in US Patent No. 4,300,981, issued Nov. 17, 1981, discloses a layered web with relatively short fibers on one or more outer surfaces of the tissue web. A layered web with shorter fibers on an outer surface and longer fibers for strength being in another layer is also disclosed by Morgan and Rich in
35 U.S. Pat. No. 3,994,771 issued Nov. 30, 1976. Similar teaching are found in U.S. Pat. No.

4,112,167 issued Sept. 5, 1978 to Dake et al. and in US Pat. No. US Patent No. 5,932,068, issued Aug. 3, 1999 to Farrington, Jr. et al. issued to Farrington et al., herein incorporated by reference. Other principles for layered web production are also disclosed in U.S. Pat. No. 3,598,696 issued to Beck and U.S. Pat. No. 3,471,367, issued to Chupka.

5 In one embodiment, the papermaking web itself comprises multiple layers having different fibers or chemical additives. Tissue in layered form can be produced with a stratified headbox or by combining two or more moist webs from separate headboxes. In one embodiment, an initial pulp suspension is fractionated into two or more fractions differing in fiber properties, such as mean fiber length, percentage of fines, percentage of
10 vessel elements, and the like. Fractionation can be achieved by any means known in the art, including screens, filters, centrifuges, hydrocyclones, application of ultrasonic fields, electrophoresis, passage of a suspension through spiral tubing or rotating disks, and the like. Fractionation of a pulp stream by acoustic or ultrasonic forces is described in P.H. Brodeur, "Acoustic Separation in a Laminar Flow", Proceedings of IEEE Ultrasonics
15 Symposium Cannes, France, pp1359-1362 (Nov. 1994), and in US Patent No. 5,803,270, "Methods and Apparatus for Acoustic Fiber Fractionation," issued Sept. 8, 1998 to Brodeur, herein incorporated by reference.

The fractionated pulp streams can be treated separately by known processes, such as by combination with additives or other fibers, or adjustment of the consistency to
20 a level suitable for paper formation, and then the streams comprising the fractionated fibers can be directed to separate portions of a stratified headbox to produce a layered tissue product.

The layered sheet may have two, three, four, or more layers. A two-layered sheet may have splits based on layer basis weights such that the lighter layer has a mass of
25 about 5% or more of the basis weight of the overall web, or about 10% or more, 20% or more, 30% or more, 40% or more, or about 50%. Exemplary weight percent splits for a three-layer web include 20%/20%/60%; 20%/60%/20%; 37.5%/25%/37.5%.; 10%/50%/40%; 40%/20%/40%; and approximately equal splits for each layer. In one embodiment, the ratio of the basis weight of an outer layer to an inner layer can be from
30 about 0.1 to about 5; more specifically from about 0.2 to 3, and more specifically still from about 0.5 to about 1.5.

A layered paper web according to the present invention can serve as a basesheet for a double print creping operation, as described in US Patent No. 3,879,257, issued Apr. 22, 1975 to Gentile et al., previously incorporated by reference.

Definitions and Test Methods

As used herein, a material is said to be "absorbent" if it can retain an amount of water equal to at least 100% of its dry weight as measured by the test for Intrinsic Absorbent Capacity given below (i.e., the material has an Intrinsic Absorbent Capacity of at about 1 or greater). For example, the absorbent materials used in the absorbent members of the present invention can have an Intrinsic Absorbent Capacity of about 2 or greater, more specifically about 4 or greater, more specifically still about 7 or greater, and more specifically still about 10 or greater, with exemplary ranges of from about 3 to about 30 or from about 4 to about 25 or from about 12 to about 40.

As used herein, "Intrinsic Absorbent Capacity" refers to the amount of water that a saturated sample can hold relative to the dry weight of the sample and is reported as a dimensionless number (mass divided by mass). The test is performed according to Federal Government Specification UU-T-595b. It is made by cutting a 10.16 cm long by 10.16 cm wide (4 inch long by 4 inch wide) test sample, weighing it, and then saturating it with water for three minutes by soaking. The sample is then removed from the water and hung by one corner for 30 seconds to allow excess water to be drained off. The sample is then re-weighed, and the difference between the wet and dry weights is the water pickup of the sample expressed in grams per 10.16 cm long by 10.16 cm wide sample. The Intrinsic Absorbent Capacity value is obtained by dividing the total water pick-up by the dry weight of the sample. If the material lacks adequate integrity when wet to perform the test without sample disintegration, the test method may be modified to provide improved integrity to the sample without substantially modifying its absorbent properties. Specifically, the material may be reinforced with up to 6 lines of hot melt adhesive having a diameter of about 1 mm applied to the outer surface of the article to encircle the material with a water-resistant band. The hot melt should be applied to avoid penetration of the adhesive into the body of the material being tested. The corner on which the sample is hung in particular should be reinforced with external hot melt adhesive to increase integrity if the untreated sample cannot be hung for 30 seconds when wet.

As used herein, "absorbent capacity" refers to the total mass of water that a specified quantity of absorbent material can hold, and is simply the Intrinsic Absorbent Capacity multiplied by the dry mass of the absorbent material. Thus 10 g of material having an Intrinsic Absorbent Capacity of 5 has an absorbent capacity of 50 g (or about 50 ml of fluid).

As used herein, a material is said to be "deformable" if the thickness of the material between parallel platens at a compressive load of 100 kPa is at least 5% greater

than the thickness of the material between parallel platens at a compressive load of 1000 kPa.

"Water retention value" (WRV) is a measure that can be used to characterize some fibers useful for purposes of this invention. WRV is measured by dispersing
5 0.5 gram of fibers in deionized water, soaking overnight, then centrifuging the fibers in a 4.83 cm (1.9 inch) diameter tube with an 0.15 mm (100 mesh) screen at the bottom at 1000 gravities for 20 minutes. The samples are weighed, then dried at 105° C for two hours and then weighed again. WRV is (wet weight - dry weight)/dry weight. Fibers useful for purposes of this invention can have a WRV of about 0.7 or greater, more specifically
10 from about 1 to about 2. High yield pulp fibers typically have a WRV of about 1 or greater.

"Papermaking fibers," as used herein, include all known cellulosic fibers or fiber mixes comprising cellulosic fibers. Fibers suitable for making the webs of this invention comprise any natural or synthetic cellulosic fibers including, but not limited to nonwoody fibers, such as cotton, abaca, kenaf, sabai grass, flax, esparto grass, straw, jute hemp,
15 bagasse, milkweed floss fibers, and pineapple leaf fibers; and woody fibers such as those obtained from deciduous and coniferous trees, including softwood fibers, such as northern and southern softwood kraft fibers; hardwood fibers, such as eucalyptus, maple, birch, and aspen. Woody fibers can be prepared in high-yield or low-yield forms and can be pulped in any known method, including kraft, sulfite, high-yield pulping methods and other
20 known pulping methods. Fibers prepared from organosolv pulping methods can also be used, including the fibers and methods disclosed in US Patent No. 4,793,898, issued Dec. 27, 1988 to Laamanen et al.; US Patent No. 4,594,130, issued June 10, 1986 to Chang et al.; and US Pat. No. 3,585,104. Useful fibers can also be produced by anthraquinone pulping, exemplified by US Patent No. 5,595,628, issued Jan. 21, 1997 to Gordon et al. A
25 portion of the fibers, such as up to 50% or less by dry weight, or from about 5% to about 30% by dry weight, can be synthetic fibers such as rayon, polyolefin fibers, polyester fibers, bicomponent sheath-core fibers, and the like. An exemplary polyethylene fiber is Pulpex®, available from Hercules, Inc. (Wilmington, DE).

Any known bleaching method can be used. Synthetic cellulose fiber types include
30 rayon in all its varieties and other fibers derived from viscose or chemically modified cellulose. Chemically treated natural cellulosic fibers can be used such as mercerized pulps, chemically stiffened or crosslinked fibers, or sulfonated fibers. For good mechanical properties in using papermaking fibers, it can be desirable that the fibers be relatively undamaged and largely unrefined or only lightly refined. While recycled fibers can be
35 used, virgin fibers are generally useful for their mechanical properties and lack of

contaminants. Mercerized fibers, regenerated cellulosic fibers, cellulose produced by microbes, rayon, and other cellulosic material or cellulosic derivatives can be used. Suitable papermaking fibers can also include recycled fibers, virgin fibers, or mixes thereof. In certain embodiments capable of high bulk and good compressive properties, 5 the fibers can have a Canadian Standard Freeness of at least 200, more specifically at least 300, more specifically still at least 400, and most specifically at least 500.

As used herein, "high yield pulp fibers" are those papermaking fibers of pulps produced by pulping processes providing a yield of about 65 percent or greater, more specifically about 75 percent or greater, and still more specifically from about 75 to about 10 95 percent. Yield is the resulting amount of processed fiber expressed as a percentage of the initial wood mass. High yield pulps include bleached chemithermomechanical pulp (BCTMP), chemithermomechanical pulp (CTMP), pressure/pressure thermomechanical pulp (PTMP), thermomechanical pulp (TMP), thermomechanical chemical pulp (TMCP), high yield sulfite pulps, and high yield Kraft pulps, all of which contain fibers having high 15 levels of lignin. Characteristic high-yield fibers can have lignin content by mass of about 1% or greater, more specifically about 3% or greater, and still more specifically from about 2% to about 25%. Likewise, high yield fibers can have a kappa number greater than 20, for example. In one embodiment, the high-yield fibers are predominately softwood, such as northern softwood or, more specifically, northern softwood BCTMP.

As used herein, the term "cellulosic" is meant to include any material having 20 cellulose as a major constituent, and specifically comprising at least 50 percent by weight cellulose or a cellulose derivative. Thus, the term includes cotton, typical wood pulps, nonwoody cellulosic fibers, cellulose acetate, cellulose triacetate, rayon, thermomechanical wood pulp, chemical wood pulp, debonded chemical wood pulp, 25 milkweed, or bacterial cellulose.

As used herein, the "wet:dry ratio" is the ratio of the geometric mean wet tensile strength divided by the geometric mean dry tensile strength. Geometric mean tensile strength (GMT) is the square root of the product of the machine direction tensile strength and the cross-machine direction tensile strength of the web. Unless otherwise indicated, 30 the term "tensile strength" means "geometric mean tensile strength." The absorbent webs used in the present invention can have a wet:dry ratio of about 0.1 or greater and more specifically about 0.2 or greater. Tensile strength can be measured using an Instron tensile tester using a 3-inch jaw width (sample width), a jaw span of 2 inches (gauge length), and a crosshead speed of 25.4 centimeters per minute after maintaining the 35 sample under TAPPI conditions for 4 hours before testing. The absorbent webs of the

present invention can have a minimum absolute ratio of dry tensile strength to basis weight of about 0.01 gram/gsm, specifically about 0.05 grams/gsm, more specifically about 0.2 grams/gsm, more specifically still about 1 gram/gsm and most specifically from about 2 grams/gsm to about 50 grams/gsm.

5 As used herein, the term "polymeric web" refers to a porous or nonporous layer primarily composed of polymeric material, and can be a nonwoven web, a plastic film, a polymeric film, an apertured film, or a layer of foam. Polymeric webs can be used as wicking barriers, baffle layers, backsheets, and, if sufficiently liquid pervious, as topsheets of absorbent articles. A polymeric web can consist of about 50 weight percent or more
10 polymeric material, more specifically about 80 weight percent or more polymeric material, and most specifically about 90 weight percent or more polymeric material. Exemplary materials include polyolefins, polyesters, polyvinyl compounds, and polyamides.

As used herein, "bulk" and "density," unless otherwise specified, are based on an oven-dry mass of a sample and a thickness measurement made at a load of 0.34 kPa
15 (0.05 psi) with a 7.62-cm (three-inch) diameter circular platen. Details for thickness measurements and other forms of bulk are described hereafter.

As used herein, "Debonded Void Thickness" is a measure of the void volume at a microscopic level along a section of the web, which can be used to discern the differences between densified and undensified portions of the tissue or between portions that have
20 been highly sheared and those that have been less sheared. The test method for measuring "Debonded Void Thickness" is described in US Patent No. 5,411,636, "Method for Increasing the Internal Bulk of Wet-Pressed Tissue," issued May. 2, 1995 to Hermans et al, herein incorporated by reference in its entirety. Specifically, Debonded Void Thickness is the void area or space not occupied by fibers in a cross-section of the web
25 per unit length. It is a measure of internal web bulk (as distinguished from external bulk created by simply molding the web to the contour of the fabric). The "Normalized Debonded Void Thickness" is the Debonded Void Thickness divided by the weight of a circular, four inch diameter sample of the web. The determination of these parameters is described in connection with FIGS. 8-13 of US Patent No. 5,411,636. Debonded Void
30 Thickness reveal some aspects of asymmetrically imprinted or molded tissue. For example, Debonded Void Thickness, when adapted for measurement of a short section of a protrusion of a molded web by using a suitably short length of a cross-directional cross-section, can reveal that the leading side of a protrusion has a different degree of bonding than the trailing side, with average differences of about 10% or more or of about 30% or
35 more being contemplated.

As used herein, "elastic modulus" is a measure of slope of stress-strain of a web taken during tensile testing thereof and is expressed in units of kilograms of force. Tappi conditioned samples with a width of 3 inches are placed in tensile tester jaws with a gauge length (span between jaws) of 2 inches. The jaws move apart at a crosshead speed of 5 25.4 cm/min and the slope is taken as the least squares fit of the data between stress values of 50 grams of force and 100 grams of force, or the least squares fit of the data between stress values of 100 grams of force and 200 grams of force, whichever is greater. If the sample is too weak to sustain a stress of at least 200 grams of force without failure, an additional ply is repeatedly added until the multi-ply sample can withstand at 10 least 200 grams of force without failure.

As used herein, the term "hydrophobic" refers to a material having a contact angle of water in air of at least 90 degrees. In contrast, as used herein, the term "hydrophilic" refers to a material having a contact angle of water in air of less than 90 degrees.

As used herein, the term "surfactant" includes a single surfactant or a mixture of 15 two or more surfactants. If a mixture of two or more surfactants is employed, the surfactants may be selected from the same or different classes, provided only that the surfactants present in the mixture are compatible with each other. In general, the surfactant can be any surfactant known to those having ordinary skill in the art, including anionic, cationic, nonionic and amphoteric surfactants. Examples of anionic surfactants 20 include, among others, linear and branched-chain sodium alkylbenzenesulfonates; linear and branched-chain alkyl sulfates; linear and branched-chain alkyl ethoxy sulfates; and silicone phosphate esters, silicone sulfates, and silicone carboxylates such as those manufactured by Lambent Technologies, located in Norcross, Georgia. Cationic surfactants include, by way of illustration, tallow trimethylammonium chloride and, more 25 generally, silicone amides, silicone amido quaternary amines, and silicone imidazoline quaternary amines. Examples of nonionic surfactants, include, again by way of illustration only, alkyl polyethoxylates; polyethoxylated alkylphenols; fatty acid ethanol amides; dimethicone copolyol esters, dimethiconol esters, and dimethicone copolyols such as those manufactured by Lambent Technologies ; and complex polymers of ethylene oxide, 30 propylene oxide, and alcohols. One exemplary class of amphoteric surfactants are the silicone amphoteric manufactured by Lambent Technologies (Norcross, Georgia).

As used herein, "softening agents," sometimes referred to as "debonders," can be used to enhance the softness of the tissue product and such softening agents can be incorporated with the fibers before, during or after dispersing. Such agents can also be 35 sprayed, printed, or coated onto the web after formation, while wet, or added to the wet

end of the tissue machine prior to formation. Suitable agents include, without limitation, fatty acids, waxes, quaternary ammonium salts, dimethyl dihydrogenated tallow ammonium chloride, quaternary ammonium methyl sulfate, carboxylated polyethylene, cocamide diethanol amine, coco betaine, sodium lauryl sarcosinate, partly ethoxylated
5 quaternary ammonium salt, distearyl dimethyl ammonium chloride, polysiloxanes and the like. Examples of suitable commercially available chemical softening agents include, without limitation, Berocell 596 and 584 (quaternary ammonium compounds) manufactured by Eka Nobel Inc., Adogen 442 (dimethyl dihydrogenated tallow ammonium chloride) manufactured by Sherex Chemical Company, Quasoft 203 (quaternary
10 ammonium salt) manufactured by Quaker Chemical Company, and Arquad 2HT-75 (dihydrogenated tallow) dimethyl ammonium chloride) manufactured by Akzo Chemical Company. Suitable amounts of softening agents will vary greatly with the species selected and the desired results. Such amounts can be, without limitation, from about 0.05 to about 1 weight percent based on the weight of fiber, more specifically from about 0.25 to about
15 0.75 weight percent, and still more specifically about 0.5 weight percent.

As used herein, "wet strength agents" are materials used to immobilize the bonds between fibers in the wet state. Typically, the means by which fibers are held together in paper and tissue products involve hydrogen bonds and sometimes combinations of hydrogen bonds and covalent and/or ionic bonds. In the present invention, it can be useful
20 to provide a material that will allow bonding of fibers in such a way as to immobilize the fiber-to-fiber bond points and make them resistant to disruption in the wet state. In this instance, the wet state usually will mean when the product is largely saturated with water or other aqueous solutions, but could also mean significant saturation with body fluids such as urine, blood, mucus, menses, runny bowel movement, lymph and other body
25 exudates.

There are a number of materials commonly used in the paper industry to impart wet strength to paper and board that are applicable to this invention. These materials are known in the art as "wet strength agents" and are commercially available from a wide variety of sources. Any material that when added to a paper web or sheet results in
30 providing the sheet with a mean wet geometric tensile strength:dry geometric tensile strength ratio in excess of 0.1 will, for purposes of this invention, be termed a wet strength agent. Typically these materials are termed either as permanent wet strength agents or as "temporary" wet strength agents. For the purposes of differentiating permanent from temporary wet strength, permanent will be defined as those resins which, when
35 incorporated into paper or tissue products, will provide a product that retains more than

50% of its original wet strength after exposure to water for a period of at least five minutes. Temporary wet strength agents are those which show less than 50% of their original wet strength after being saturated with water for five minutes. Both classes of material find application in the present invention. The amount of wet strength agent added to the pulp fibers can be at least about 0.1 dry weight percent, more specifically about 0.2 dry weight percent or greater, and still more specifically from about 0.1 to about 3 dry weight percent, based on the dry weight of the fibers.

Permanent wet strength agents will provide a more or less long-term wet resilience to the structure. In contrast, the temporary wet strength agents would provide structures that had low density and high resilience, but would not provide a structure that had long-term resistance to exposure to water or body fluids. The mechanism by which the wet strength is generated has little influence on the products of this invention as long as the essential property of generating water-resistant bonding at the fiber/fiber bond points is obtained.

Suitable permanent wet strength agents are typically water soluble, cationic oligomeric or polymeric resins that are capable of either crosslinking with themselves (homocrosslinking) or with the cellulose or other constituent of the wood fiber. The most widely-used materials for this purpose are the class of polymer known as polyamide-polyamine-epichlorohydrin type resins. These materials have been described in patents issued to Keim (US Patent 3,700,623 and US Patent 3,772,076) and are sold by Hercules, Inc., located in Wilmington, Delaware, as KYMENE 557H polyamine-epichlorohydrin resins. Related materials are marketed by Henkel Chemical Co., located in Charlotte, North Carolina, and Georgia-Pacific Resins, Inc., located in Atlanta, Georgia.

Polyamide-epichlorohydrin resins are also useful as bonding resins in this invention. Materials developed by Monsanto and marketed under the SANTO RES™ label are base-activated polyamide-epichlorohydrin resins that can be used in the present invention. These materials are described in patents issued to Petrovich (US Patent 3,885,158; US Patent 3,899,388; US Patent 4,129,528 and US Patent 4,147,586) and van Eenam (US Patent 4,222,921). Although they are not as commonly used in consumer products, polyethylenimine resins are also suitable for immobilizing the bond points in the products of this invention. Another class of permanent-type wet strength agents are exemplified by the aminoplast resins obtained by reaction of formaldehyde with melamine or urea.

Suitable temporary wet strength resins include, but are not limited to, those resins that have been developed by American Cyanamid and are marketed under the name

PAREZ™ 631 NC wet strength resin (now available from Cytex Industries, located in West Paterson, New Jersey). This and similar resins are described in US Patent 3,556,932 to Coscia et al. and US Patent 3,556,933 to Williams et al. Other temporary wet strength agents that should find application in this invention include
5 modified starches such as those available from National Starch and marketed as CO-BOND™ 1000 modified starch. It is believed that these and related starches are disclosed in US Patent 4,675,394 to Solarek et al. Derivatized dialdehyde starches may also provide temporary wet strength. It is also expected that other temporary wet strength materials such as those described in US Patent 4,981,557; US Patent 5,008,344 and US
10 Patent 5,085,736 to Bjorkquist would be of use in this invention. With respect to the classes and the types of wet strength resins listed, it should be understood that this listing is simply to provide examples and that this is neither meant to exclude other types of wet strength resins, nor is it meant to limit the scope of this invention.

Although wet strength agents as described above find particular advantage for use
15 in connection with this invention, other types of bonding agents can also be used to provide the necessary wet resiliency. They can be applied at the wet end of the basesheet manufacturing process or applied by spraying or printing after the basesheet is formed or after it is dried.

The efficacy of cationic wet strength agents can be enhanced by treatment of
20 cellulosic fibers with reactive anionic compounds, according to US Patent No. 5,935,383, "Method for Improved Wet Strength Paper," issued Aug. 10, 1999 to Sun and Lindsay, herein incorporated by reference.

Thickness and Bulk Measurement

Thickness and other geometrical features of the web at a microscopic level can be
25 determined using computer-assisted image analysis of microtomed plastic sections of the webs, imaged by polarized light optical microscopy. Thin optical sections provide a 2-dimensional field suitable for analysis. For example, microtomed sections can be prepared by infiltrating the dry webs in silicone molds with low-viscosity epoxy resin available from Ladd Research Industries, Ltd., Burlington, Vermont. The resin is polymerized for 36
30 hours at 65°C. Ten micrometer thick sections are cut from each block using a steel knife microtome, coverslipped on a glass slide then examined using polarized light optical microscopy. Randomly selected image fields of each material section are digitized from the microscope using a Dage MT1 VE 1000 CCD monochrome camera, and analyzed using a Sun Sparc20 workstation running PGT IMIX Feature Analysis software, available

from Princeton Gamma Tech. Inc., 1200 State Rd., Princeton New Jersey. Image magnification can be 10x, with image calibration is performed using a certified stage micrometer (Graticules Ltd., Part #S8 McCrone Associates), divided into 10 micrometer increments. The polarized light images are binarized and processed to fill holes or
5 inclusion voids in the fibers.

The microtomed cross-sections of the web can then be analyzed using the principles described in US Patent No. 5,904,811, issued May. 18, 1999 to Ampulski et al., previously incorporated by reference, to obtain specific parameters such as P, K, and T as shown in FIG. 3A.

10 “Macro-caliper” as used herein means the macroscopic thickness of the sample at an applied pressure of about 15 g/square cm (0.21 psi). The sample is placed on a horizontal flat surface and confined between the flat surface and a load foot having a horizontal loading surface, where the load foot loading surface has a circular surface area of about 3.14 square inches and applies a confining pressure of about 15 g/square cm
15 (0.21 psi) to the sample. The macro-caliper is the resulting gap between the flat surface and the load foot loading surface. The macro-caliper is an average of at least five measurements. Thickness measurements of samples are made in a TAPPI-conditioned room (50% relative humidity and 23°C) after conditioning for four hours. Samples should be essentially flat and uniform under the area of the contacting platen.

20 For macroscopic thickness measurement to give an overall thickness of the sheet for use in calculating the “bulk” of the web, as used herein, the thickness measurement is conducted on a stack of five sheets at a load of 0.05 psi using a three-inch diameter circular platen to apply the load. Samples are measured after conditioned for four hours in a TAPPI-conditioned room. The sheets rest beneath the flat platen and above a flat
25 surface parallel to the platen. The platen is connected to a thickness gauge such as a Mitutoyo digital gauge which senses the displacement of the platen caused by the presence of the sheets. Samples should be essentially flat and uniform under the contacting platen. Bulk is calculated by dividing the thickness of five sheets by the basis weight of the five sheets (conditioned mass of the stack of five sheets divided by the area
30 occupied by the stack, which is the area of a single sheet). Bulk is expressed as volume per unit mass in cc/g and density is the inverse, g/cc.

One alternative measure of bulk is the “Ampulski Bulk,” which, as used herein, uses the “macro-caliper” measurement described above to obtain the bulk at a load of 15 g/cm² (0.21 psi) with a platen having a circular surface area of about 3.14 square inches.

As used herein, "Wet Bulk" is based on a caliper measurement of a stack of five sheets of a sample according to the definition of bulk above (at 0.05 psi), except that the conditioned sample is then uniformly misted with deionized water until the moistened mass of the sample is 250% of the dry mass of the sample (i.e., the added mass of the moisture is 150% of the dry sample weight) and then measured for thickness. If the sample cannot absorb and retain enough moisture from misting to increase the mass by 150%, then the highest level of achievable moisture add-on below 150% but still above 100% moisture add on should be used. The Wet Bulk is calculated as the thickness of the substantially planar moistened sample under a load of 0.344 kPa (0.05 psi) divided by the conditioned sample basis weight, yielding a value with units of g/cc. Absorbent fibrous structures of the present invention can have a Wet Bulk of about 4 cc/g or greater, more specifically about 6 cc/g or greater, more specifically still about 8 cc/g or greater, more specifically still about 10 cc/g or greater, and most specifically about 15 cc/g or greater, with an exemplary range of from about 6 cc/g to about 25 cc/g.

As used herein, "local thickness" refers to the distance between the two opposing surfaces of a web along a line substantially normal to both surfaces. The measurement is a reflection of the actual thickness of the web at a particular location, as opposed to the micro-caliper.

Web Stiffness

Web stiffness as used herein is defined as the slope of the tangent of the graph of force (in grams/centimeter of sample width) versus strain (cm elongation per cm of gage length). Web flexibility increases, and web stiffness decreases, as the slope of the tangent decreases. For creped samples the tangent slope is obtained at 15 g/cm force, and for non-creped samples the tangent slope is obtained at 40 g/cm force. Such data may be obtained using a Syntech Universal Testing Machine, with a cross head speed of 1 inch per minute and a sample width of about 4 inches for creped samples, and 0.1 inch per minute and a sample width of about 1 inch for non-creped handsheets. The Total Stiffness index (TS) as used herein means the geometric mean of the machine-direction tangent slope and the cross-machine-direction tangent slope. Mathematically, this is the square root of the product of the machine-direction tangent slope and cross-machine-direction tangent slope in grams per centimeter. For handsheets, only the machine direction tangent slope is measured, and the value of TS is taken to be the machine direction tangent slope. The value of TS is reported as an average of at least five

measurements. TS can be normalized by Total Tensile to provide a normalized stiffness index TS/TT.

Surface Friction Hysteresis

The coefficient of friction can be measured with known devices which drag a probe
5 over the surface of a paper sample at a constant rate. The probe is modified to be a
circular 2-centimeter diameter 40-60 micron glass frit, lying flat, applying a 12.5 g normal
force to the sample, and it is advanced over the tissue at a rate of 1 mm/sec. The tissue
sample is conditioned for four hours in a TAPPI conditioned room (73°F and 50% relative
humidity), and the test is conducted under the same conditions. The probe is advanced 5
10 cm in a first direction, providing data for a "forward" scan, and then is reversed to travel
back to the beginning point at the same speed, providing data for the "reverse" scan. The
coefficient of friction can be calculated by dividing the frictional force by the normal force
measured during the scan (neglecting the initial static resistance). The frictional force is
the lateral force on the probe during the scanning, an output of the instrument. After a first
15 test comprising a forward and reverse scan, the sample is rotated 180 degrees and
repositioned for a second test with another forward and reverse pair of scans along a new
path, such that the forward scan of the second test is in the same direction as the reverse
scan in the first test. The coefficient of friction for the forward scan of the second test and
the reverse scan in the first test are averaged to give the coefficient of friction in a first
20 direction, and the coefficient of friction for the reverse scan of the second test and the
forward scan in the first test are averaged to give the coefficient of friction in a second
direction opposite to the first direction. This process is repeated for 50 samples to yield
averaged coefficients of frictions for the two directions. If the average coefficient of friction
in one direction is at least 10% greater than the average coefficient of friction in the
25 opposite direction, the tissue is said to have surface friction hysteresis. The ratio of the
absolute difference in average coefficient of friction for the two directions divided by the
smaller of the two average coefficients of friction, expressed as a percentage, is the
Surface Friction Hysteresis Factor, as used herein. For some embodiments of the present
invention, the Surface Friction Hysteresis Factor can be 20% or greater, more specifically
30 about 30% or greater, more specifically still about 50% or greater, and most specifically
about 100% or greater, with an exemplary range of 25% to 150%.

In some cases, the mean deviation in the coefficient of friction is more useful in
distinguishing the roughness of certain samples than is the coefficient of friction per se.
Therefore, frictional hysteresis can also be quantified by comparison of the mean absolute

deviation of the coefficient of friction, sometimes called the Stick and Slip Coefficient of Friction (hereafter SSCOF; a related discussion is given in US Patent No. 4,959,125, issued Sep. 25, 1990 to Spindel, herein incorporated by reference to the extent consistent herewith). The SSCOF value in one direction (averaged for two scans in the same direction on parallel pathways as described above) is compared to the SSCOF value in the opposite direction (also averaged for two scans), and a percentage difference is expressed relative to the smaller of the two DEVCOF values, and this percentage value is averaged for similar runs on 50 samples to yield the Stick and Slip Hysteresis Factor. The Stick and Slip Hysteresis Factor for a product type made according to the present invention can be about 20% or greater, more specifically about 30% or greater, more specifically still about 50% or greater, and most specifically about 100% or greater, with an exemplary range of 25% to 250%.

Exemplary friction measurement devices which can be adapted for the friction test of the present invention include the KES-FB4 friction, roughness tester of the Kawabata softness system, commercially available from Kato Tech Co., Ltd. 26 Karato-Cho, Nishikujo Minami-Ku, Kyoto 601 Japan (see "Methods for the Measurement of the Mechanical Properties of Tissue Paper", Ampulski, et. al., 1991 International Paper Physics Conference, published by TAPPI press, and incorporated herein by reference) and the Kett 14DR Multi-purpose Test System (Kett, Inc., Villa Park, CA). In conducting the test, care must be taken to ensure that the frit applies a uniform load. If the instrument cannot do a forward and reverse scan or cannot be modified to do so effectively, the sample can be rotated 180 degrees and translated appropriately for measurement on the same pathway as an initial scan to force a reverse scan, in effect. The frit must be kept clean. If used with tissue comprising an emollient, for example, a new frit should be used after each pair of scans on two pathways has been completed.

The tissue showing hysteresis in surface friction can be creped or uncreped, and can be a single ply or a multi-ply product. If the tissue has been embossed, measurement in an unembossed region should be reported, if possible.

30 EXAMPLE 1

Laserworks, a division of Stencil Aire, Inc., (Green Lake, Wisconsin), was commissioned to laser drill 1-millimeter thick sheets of flexible plastic (PETG) with a geometry according to the specifications of US Patent No. 4,528,239, issued Jul. 9, 1985 to Trokhan, based on FIG. 10 thereof, reproduced as FIG. 9 of the present application. The written description from the Trokhan patent reads in pertinent part:

Openings are in the form of nonregular six-sided figures. Reference letter "a" represents the angle between the two sides of an opening as illustrated, "f" the point-to-point height of an opening, "c" the CD spacing between adjacent openings, "d" the diameter of the largest circle which can be inscribed in an opening, "e" the width between flats of an opening, "g" the spacing between two adjacent openings in a direction intermediate MD and CD, and "b" the shortest distance (in either MD or CD) between the centerlines of two MD or CD adjacent openings. In this version, "a" is 135°, "c" is 0.56 millimeter (0.022 inch), "e" is 1.27 mm (0.050 in.), "f" is 1.62 mm (0.064 in.), "g" is 0.20 mm (0.008 in.) and the ratio of "d" to "b" is 0.63. A deflection member constructed to this geometry has an open area of about 69%.

This description was submitted to Laserworks and was used to program a computer-controlled laser engraving device which drilled holes into four 30.5-cm square sections of the PETG plastic to simulate the fabric produced by Trokhan. An undrilled rim remained around the edges of each plastic square having a width of 1.3 cm. The edges of the plastic squares were trimmed from 1.3 cm to 2 mm and then beveled at a 45 degree angle. A coarse polyester thread was used to sew a laser-drilled sheet onto an Asten 920 through drying fabric (AstenJohnson Corp., Appleton, Wisconsin), with the thread passing through laser-drilled holes near the rim of the plastic sheet and passing into the weave of the Asten 920 fabric. The laser-drilled sheet was sewn onto the "chute side" (the backside having dominant cross-direction chutes) of the TAD fabric. The TAD fabric was placed in a pilot paper machine with a through dryer, with the fabric inverted such that the chute side would be the paper contacting side. (The front side, with dominant warps, is normally the paper-contacting side of the fabric for commercial operation.)

The pilot paper machine was operated in a configuration for production of uncreped through-air dried tissue. The machine had a width of 22 inches and comprised a flow spreader which deposited an aqueous slurry at about 0.2% consistency onto a forming wire traveling at about 50 feet per minute, at a flow rate sufficient to product tissue having a basis weight of 40 grams per square meter, produced from 100% bleached kraft northern softwood (LL-19 from Kimberly-Clark Corp.) with 16 pounds per ton of Parex NC 631 added, a strength additive produced by Hercules, Inc. (Wilmington, DE). The forming section had a vacuum box and foils for dewatering the web to a consistency of about 12%, followed by a transfer section in which the embryonic web was

transferred from the forming fabric onto a second fine carrier fabric, wherein a vacuum shoe assisted the transfer. The web was transferred from the carrier fabric onto the sanded Asten 920 TAD fabric backed by a curved vacuum shoe to assist in transfer, wherein the TAD fabric was moving at a velocity 10% slower than the velocity of the carrier fabric to impart foreshortening to the web ("rush transfer"). After the rush transfer operation, the web passed through a Valmet through dryer operating at a hood temperature of about 300°F to further dry the web to a consistency of about 95%. The web was removed from the TAD fabric after through drying and wound onto a reel without creping to produce an uncreped web.

10 With only one section of the laser-drilled plastic sewn onto the TAD fabric, only one short section of tissue was molded by the laser-drilled plastic for each complete revolution of the TAD fabric. While the laser-drilled fabric did permit molding of the tissue web, the bulk of the molded section was generally less than bulk of the tissue through-dried against the sanded Asten 920 fabric. Without wishing to be bound by theory, it is believed that the lower bulk imparted by the Trokhan fabric was at least partly because the flow resistance of the two layers of fabric, the Asten 920 fabric and the added laser-drilled fabric, hindered the effect of the air pressure differential during rush transfer and through drying such that that molding was not as thorough as it could have been were the base fabric (the Asten 920) not present. Nevertheless, the trial did demonstrate that a laser-drilled fabric simulating a deflection member could be used as a molding substrate in an uncreped through dried operation. In principle, little difficulty should be encountered in further modifying the uncreped through-drying system to serve as a creped through-drying system, in which the laser-drilled substrate would also serve as an imprinting surface for pressing the tissue against a Yankee dryer prior to creping or against another drying surface such as a heated roll or drum.

EXAMPLE 2

23-gsm handsheets of LL-19 bleached kraft northern softwood pulp were prepared having a consistency of about 30%. The handsheets were placed over the laser-drilled plastic of Example 1 and subjected to a vacuum pressure of about 10 in Hg for 5 seconds to 30 seconds to cause molding. The sheets were removed, dried, and conditioned for 4 hours under Tappi standard conditions. Bulk was measured at a load of 220 grams per square inch under a platen having a diameter of 4 1/16 inches. Bulk values ranged from about 5 to about 7 grams per cubic centimeter. The texture of the fabric was visible on the

molded handsheets, demonstrating that the laser-drilled substrate could be used for web molding.

It will be appreciated that the foregoing examples, given for purposes of
5 illustration, are not to be construed as limiting the scope of this invention. Although only a
few exemplary embodiments of this invention have been described in detail above, those
skilled in the art will readily appreciate that many modifications are possible in the
exemplary embodiments without materially departing from the novel teachings and
advantages of this invention. Accordingly, all such modifications are intended to be
10 included within the scope of this invention, which is defined in the following claims and all
equivalents thereto. Further, it is recognized that many embodiments may be conceived
that do not achieve all of the advantages of some embodiments, yet the absence of a
particular advantage shall not be construed to necessarily mean that such an embodiment
is outside the scope of the present invention.

15

We claim:

1. A paper web comprising a first relatively high density region having a first thickness K ; a second relatively low density region having a second thickness P ; and a third and a fourth region extending intermediate the first and second regions, the third and fourth regions comprising transition regions disposed adjacent the first region, the transition regions having a third thickness $T1$ and a fourth thickness $T2$ less than $T1$; wherein the thickness ratio P/K is greater than 1.0, the thickness ratio $T2/K$ is less than 0.90, and the thickness ratio $T1/T2$ is greater than about 1.1.
2. The paper web of Claim 1 wherein the second low density region having a thickness P is a dome having a midpoint line and having a local maximum in height horizontally displaced from the midpoint line by about 6% or more of the width of the dome, wherein the width is measured as the maximum horizontal distance between the outer surfaces at the base of the dome.
3. The paper web of Claim 1 wherein the high density region forms a continuous network and the low density region is disposed in discrete areas isolated by the continuous network.
4. The paper web of Claim 1 wherein the high density region and low density region form a non-random repeating pattern in the density distribution of the web.
5. The paper web of Claim 4, wherein the pattern is a bilaterally staggered array.
6. The paper web of Claim 1, further comprising a repeating pattern in the basis weight distribution of the web comprising a relatively low basis weight region and a relatively high basis weight region.
7. The paper web of Claim 6, wherein the dome has a local maximum in height selectively associated with the relatively low basis weight region.
8. The paper web of Claim 6, wherein the dome has a local maximum in height selectively associated with the relatively high basis weight region.
9. The paper web of Claim 6, wherein the high density region is selectively associated with the relatively high basis weight region.

10. The paper web of Claim 4, further comprising a non-random repeating pattern in the basis weight distribution of the web that is not registered with the non-random repeating pattern in the density distribution of the web.
- 5 11. The paper web of Claim 4, further comprising a non-random repeating pattern in the basis weight distribution of the web that is registered with the non-random repeating pattern in the density distribution of the web.
12. The paper web of Claim 1, wherein the thickness ratio $T2/K$ is less than about 0.80.
13. The paper web of Claim 1, wherein the thickness ratio P/K is at least about 1.5.
- 10 14. The paper web of Claim 1, wherein the Surface Friction Hysteresis Factor is about 20% or greater.
15. The paper web of Claim 1, wherein the Surface Friction Hysteresis Factor is about 50% or greater.
- 15 16. The paper web of Claim 1, wherein the Surface Friction Hysteresis Factor is about 100% or greater.
17. The paper web of Claim 1, wherein the Surface Friction Hysteresis Factor is about 150% or greater.
18. The paper web of Claim 1, wherein the Stick and Slip Hysteresis Factor is about 20% or greater.
- 20 19. The paper web of Claim 1, wherein the Stick and Slip Hysteresis Factor is about 50% or greater.
20. The paper web of Claim 1, wherein the Stick and Slip Hysteresis Factor is about 100% or greater.
- 25 21. The paper web of Claim 1, wherein the Stick and Slip Hysteresis Factor is about 150% or greater.
22. An uncreped paper web according to Claim 1.
23. A creped paper web according to Claim 1.

24. An embossed paper web according to Claim 1.
25. An unembossed paper web according to Claim 1.
26. A multilayered paper web according to Claim 1.
- 5 27. A multilayered paper web according to Claim 1 or 23 comprising an outer layer and one or more other layers, wherein the outer layer has a relatively higher concentration than the one or more other layers of at least one of a debonder, a silicone compound, an emollient, a lotion, a quaternary ammonium compound, a semisolid lubricant, and a wax.
- 10 28. The paper web of Claim 1 further comprising a first layer and a second layer each comprising fibers, wherein the fibers of the first layer have a shorter fiber length than the fibers of the second layer.
29. The paper web of Claim 28, wherein the first layer contacts the deflection member.
30. The paper web of Claim 28, wherein the first layer does not contact the deflection member.
- 15 31. The paper web according to Claim 1 further comprising a first layer and a second layer each comprising fibers, wherein the fibers of the first layer differ from the fibers of the second layer in at least one of chemical additives present, distribution of fiber species, fines content, color, bleaching method, and degree of refining.
- 20 32. A paper web according to Claim 1, further comprising at least about 0.02% by weight of an additive selected from a softening agent, a debonder, an emollient, a lotion, a silicone compound, and a fluoropolymer, wherein the additive is present in a higher concentration in the second low density region relative to the first high density region.
- 25 33. A paper web according to Claim 1, further comprising at least about 0.05% by weight of an additive selected from a wet strength agent, a dry strength agent, a starch, a sizing compound, a cross-linked polymer, an adhesive, and a thermoplastic, wherein the additive is present in a higher concentration in the second low density region relative to the first high density region.

34. The paper web of Claim 1 wherein the local Debonded Void Thickness taken along the third region differs by at least about 30% on the average from the local Debonded Void Thickness taken along the fourth region.
35. The paper web of Claim 1 further comprising discrete quantities of one of a liquid, an emulsion, and a slurry, contained within a lipid phase having a melting point of about 30°C or higher.
36. A calendered web according to Claim 1.
37. A calendered, creped, perforated web according to Claim 1, provided in roll form.
38. A premoistened wipe comprising the web of Claim 1.
39. A paper web comprising an imprinted region having a relatively high density, and an unimprinted, low density region comprising at least two subsets of domes, each dome having a local maximum in elevation, wherein the first subset of domes has a relatively high basis weight region associated with the local maximum, and the second subset of domes has a relatively low basis weight region associated with the local maximum, at least one of the at least two subsets of domes comprising asymmetrical domes.
40. A paper web comprising an imprinted region having a relatively high density, and an unimprinted, low density region comprising asymmetrical domes characterized by having a maximum base width along a first line in the plane of the imprinted region, wherein the point of greatest dome elevation above the first line is above a point on the first line that is offset from the midpoint of the first line by an average distance of at least 10% of the maximum base width of the dome.
41. A paper web comprising a first relatively high density region having a first local thickness K_1 ; a second relatively high density region having a second local thickness K_2 ; a relatively low density region having a local thickness P ; and a transition region having an average local thickness T ; wherein the thickness ratio P/K_1 is greater than 1.3, the thickness ratio K_1/K_2 is less than 0.90, and the thickness ratio P/T is greater than about 1.1.
42. The web of Claim 41, further comprising asymmetrical domes.

43. The web of Claim 39, 40, or 41, further having a Surface Friction Hysteresis Factor of at least 10%.
44. The paper web of Claim 39, 40, or 41, further having a Surface Friction Hysteresis Factor of at least 50%.
- 5 45. The paper web of Claim 39, 40, or 41, further having a Stick and Slip Hysteresis Factor of about 30% or greater.
46. The paper web of Claim 39, 40, or 41, further having a Stick and Slip Hysteresis Factor of about 100% or greater.
47. The paper web of Claim 39, 40, or 41, wherein the low density region is
10 discontinuous.
48. The paper web of Claim 47, wherein the low density region comprises domes in a bilaterally staggered array.
49. The paper web of Claim 39, 40, or 41 further comprising a first layer and a second
15 layer each comprising fibers, wherein the fibers of the first layer have a shorter fiber length than the fibers of the second layer.
50. The paper web of Claim 39, 40, or 41 further comprising at least one of syncline marks and anti-syncline marks.
51. A paper web comprising: a first relatively high density, continuous network region
20 having a first thickness K; a second relatively low density region comprising a plurality of discrete, relatively low density domes dispersed throughout the continuous network region and isolated one from the other by the continuous network region, the relatively low density domes having a second thickness P; wherein the thickness ratio P/K is at least about 2.0; and wherein the low density
25 domes are substantially asymmetric and wherein the web has a total tensile strength of at least 2165 meters and a normalized stiffness index of less than about 10.
52. The paper web of Claim 51, wherein the low density domes are characterized by
30 having a midpoint line displaced from the local maximum in height by about 6% or more of the width of the dome, wherein the width is measured as the maximum horizontal distance between the outer surfaces at the base of the dome.

53. The paper web of Claim 52, wherein the midpoint line is displaced from the local maximum in height by about 10% or more of the width of the dome.
54. The paper web of Claim 52, wherein the midpoint line is displaced from the local maximum in height by about 20% or more of the width of the dome.
- 5 55. The paper web of Claim 51, further comprising a transition zone between the low density dome and the continuous network region characterized by a first thickness T1 and a second thickness T2 less than T1, wherein the thickness ratio T1/T2 is greater than about 1.1.
- 10 56. The paper web of Claim 51, wherein the Surface Friction Hysteresis Factor is at least 10%.
57. The paper web of Claim 51, wherein the Surface Friction Hysteresis Factor is at least 50%.
58. The paper web of Claim 51, wherein the Surface Friction Hysteresis Factor is at least 100%.
- 15 59. The paper web of Claim 51, wherein the Stick and Slip Hysteresis Factor is about 30% or greater.
60. The paper web of Claim 51, wherein the Stick and Slip Hysteresis Factor is about 100% or greater.
- 20 61. A method of forming a paper web comprising:
- a) providing a deformable carrier fabric capable of receiving and containing water pressed from a moist web, the deformable carrier fabric having a web contacting surface and a back surface;
- b) providing a deflection member with a first web contacting surface and a second surface opposite the first surface, wherein the web contacting surface comprises a repeating pattern of raised web-contacting elements and deflection conduits;
- 25 c) providing a moist papermaking web, the web having a first face and a second face, the web residing on one of the web contacting surface of the deflection member and the web contacting surface of the deformable carrier fabric;
- 30

- 5
- 10
- d) providing a deformable material that contacts the second surface of the deflection member;
 - e) providing a compression nip between first and second opposed compression surfaces;
 - f) pressing the web in the compression nip while the web is in contact with both the deflection member and the deformable backing fabric, and while the deflection member is in contact with the deformable material; and
 - g) shearing the web while it is in the compression nip, wherein a portion of the papermaking fibers in the embryonic web are deflected into the deflection conduits of the deflection member to form a molded web.

62. The method of Claim 61, wherein shearing the web comprises transferring the web from one of the deflection member and the deformable carrier fabric traveling at a first velocity to the other one of the deflection member and the deformable carrier fabric traveling at a second velocity less than the first velocity.
- 15 63. The method of Claim 62, wherein the second velocity is at least 1% lower than the first velocity.
64. The method of Claim 62, wherein the second velocity is at least 3% lower than the first velocity.
- 20 65. The method of Claim 62, wherein the second velocity is at least 5% lower than the first velocity.
66. The method of Claim 62, wherein the second velocity is at least 0.2 meters per second lower than the first velocity.
67. The method of Claim 62, wherein the second velocity is at least 0.5 meters per second lower than the first velocity.
- 25 68. The method of Claim 62, wherein the second velocity is at least 1 meter per second lower than the first velocity.
69. The method of Claim 61 or 62, wherein the web prior to the compression nip resides on the deformable carrier fabric.
70. The method of Claim 61 or 62, wherein the web prior to the compression nip resides on the deflection member.
- 30

71. The method of Claim 61, wherein the permeability of the deformable carrier fabric is less than the permeability of the deformable material.
72. The method of Claim 61, wherein the permeability of the deformable carrier fabric is substantially the same or greater than the permeability of the deformable material.
- 5
73. The method of Claim 61, wherein the web contacting elements of the deflection member comprise a first subset of elements comprising a first resilient material and a second subset of elements comprising a second resilient material, the first subset differing substantially from the second subset in at least one of elastic modulus, storage modulus, Poisson ratio, and Shore hardness, such that shear is imparted to the web during pressing of the web in the compression nip due to differences in compressive response of the first subset and second subset of the web contacting elements of the deflection member.
- 10
74. The method of Claim 73, wherein the first subset of web contacting elements have a different elevation than the second subset of web contacting elements.
- 15
75. The method of Claim 62, wherein at least one of the first and second opposed compression surfaces comprises a deformable material.
76. The method of Claim 75, wherein at least one of the first and second opposed compression surfaces comprises a deformable material selected from rubber, a composite comprising rubber, a deformable polymer, an elastomer, and a flexible cover backed with one of a slurry, a liquid, loose particulate material, rubber, a composite comprising rubber, and deformable fibrous matter.
- 20
77. The method of Claim 61, wherein the deflection member further comprises synclines.
78. The method of Claim 61, wherein the deflection member further comprises anti-synclines.
- 25
79. A method of forming a paper web comprising the steps of:
a) providing an aqueous dispersion of papermaking fibers;
b) providing a foraminous forming member;

- 5
- 10
- 15
- 20
- 25
- c) providing a deformable carrier fabric capable of receiving and containing water pressed from a web;
 - d) providing a deflection member with a first web contacting surface and a second surface opposite the first surface, wherein the web contacting surface comprises a repeating pattern of raised web-contacting elements and deflection conduits;
 - e) providing a deformable backing fabric that contacts the second surface of the deflection member;
 - f) providing a compression nip between first and second opposed compression surfaces;
 - g) forming an embryonic web of the papermaking fibers on the foraminous forming member, the embryonic web having a first face and a second face;
 - h) transferring the embryonic web from the foraminous forming member to the deformable carrier fabric, the deformable carrier fabric traveling at a first velocity;
 - i) pressing the web in the compression nip, wherein the first compression surface contacts the deformable backing fabric, which in turn contacts the deflection member, which in turn contacts the embryonic web, which in turn contacts the deformable carrier fabric, which in turn contacts the second compression surface; and
 - j) transferring the embryonic web to the deflection member in the compression nip, wherein the deflection member travels at a second velocity less than that of the first velocity of the deformable carrier fabric, wherein a portion of the papermaking fibers in the embryonic web are deflected into the deflection conduits of the deflection member to form a molded web.

80. The method of Claim 79, wherein water is expressed from the embryonic web in the compression nip and received by at least one of the deformable carrier fabric and the deformable backing fabric.

81. The method of Claim 79, further comprising through drying of the web.

82. The method of Claim 79, further comprising pressing the deflection member and the web carried thereon onto a drum dryer to transfer the web onto the drum dryer.

83. The method of Claim 79, wherein the deflection member is liquid pervious and wherein the deflection conduits of the deflection member are in fluid communication with the deformable backing fabric.
84. The method of Claim 79, wherein the deflection member is liquid impervious.
- 5 85. The method of Claim 79, wherein the deflection member is joined to the deformable backing fabric to form a composite deflection member.
86. The method of Claim 79, wherein providing an aqueous dispersion of papermaking fibers comprises providing a plurality of fiber furnishes in separate streams, and wherein forming an embryonic web comprises forming a multilayered embryonic web from the plurality of fiber furnishes.
- 10 87. The method of Claim 86, further comprising fractionating a fiber slurry into two or more fractions, wherein the plurality of fiber furnishes comprise the two or more fractions.
88. A method of forming a paper web comprising:
- 15 a) providing an aqueous dispersion of papermaking fibers;
- b) providing a foraminous forming member;
- c) providing a deformable carrier fabric;
- d) providing a deformable backing fabric;
- e) providing a compression nip having first and second opposed
- 20 compression surfaces;
- f) providing an deflection member having a web contacting face comprising a web deflection member and a deflection conduit portion;
- g) forming an embryonic web of the papermaking fibers on the foraminous forming member, the embryonic web having a first face in contact with
- 25 the forming member and an opposing second face;
- h) transferring the embryonic web from the foraminous forming member to the deformable carrier fabric traveling at a first velocity, such that that the second face of the embryonic web is in contact with the forming member;
- i) passing the embryonic web riding on the deformable carrier fabric
- 30 through a compression nip with the web in contact with the deflection member, wherein the elements in the compression nip comprise, in order, the second compression surface, the deformable backing fabric,

- the deflection member, the embryonic web, the deformable carrier fabric, and the first compression surface, and wherein the embryonic web is transferred to the deflection member which travels at a second velocity less than the first velocity of the deformable carrier fabric;
- 5 j) deflecting a portion of the papermaking fibers in the embryonic web into the deflection conduit portion while in the compression nip and expelling water from the embryonic web which is received by at least one of the deformable backing fabric and the deformable carrier fabric to form a molded web of papermaking fibers;
- 10 k) removing the web from the compression nip wherein the web remains in contact with the deflection member and not the deformable carrier fabric; and
- l) drying the web.
89. The method of Claim 88, wherein drying the web comprises passing heated air
- 15 through the web as it is in contact with the deflection member.
90. The method of Claim 88, wherein drying the web comprises pressing the deflection member and the web against the surface of a dryer drum, wherein the web is transferred from the deflection member to the dryer drum.
91. The method of Claim 88, wherein drying the web comprises pressing the deflection
- 20 member and the web against the surface of a dryer drum, wherein the web is not transferred from the deflection member to the dryer drum.
92. The method of Claim 79 or 88 further comprising dewatering the embryonic web prior to the compression nip by at least one of displacement dewatering, air press dewatering, and capillary dewatering.
- 25 93. A method of forming a paper web comprising the steps of:
- a) providing an aqueous dispersion of papermaking fibers;
- b) providing a foraminous forming member;
- c) providing a deformable carrier fabric capable of receiving and containing water pressed from a web, the deformable carrier fabric comprising an
- 30 apertured polymeric web;
- d) providing a deflection member with a first web contacting surface and a second surface opposite the first surface, wherein the web contacting

- surface comprises a repeating pattern of raised web-contacting elements and deflection conduits;
- e) providing a deformable backing fabric that contacts the second surface of the deflection member;
- 5 f) providing a compression nip between first and second opposed compression surfaces;
- g) forming an embryonic web of the papermaking fibers on the foraminous forming member, the embryonic web having a first face and a second face;
- 10 h) transferring the embryonic web from the foraminous forming member into the compression nip, wherein the first compression surface contacts the deformable backing fabric, which in turn contacts the deflection member, which in turn contacts the embryonic web, which in turn contacts the deformable carrier fabric, which in turn contacts the second compression
- 15 surface;
- i) pressing the web in the compression nip wherein a portion of the papermaking fibers in the embryonic web are deflected into the deflection conduits of the deflection member to form a molded web; and
- j) drying the web.
- 20 94. The method of Claim 93, wherein the apertured polymeric web imparts a visually detectable pattern onto the web during pressing.
95. The method of Claim 93, wherein the apertured polymeric web comprises a polymeric network having polymeric elements at a plurality of elevations relative to the base plane of the deformable carrier fabric.
- 25 96. The method of Claim 95, further comprising foreshortening the web.
97. The method of Claim 93, wherein the compression nip is formed by a shoe press.
98. The method of Claim 93, wherein forming the embryonic web comprises forming a multilayered embryonic web from a stratified headbox.
99. A method of forming a paper web comprising the steps of:
- 30 a) providing an aqueous dispersion of papermaking fibers;
- b) providing a foraminous forming member;

- 5
- 10
- 15
- 20
- 25
- c) providing a deformable carrier fabric capable of receiving and containing water pressed from a web;
 - d) providing an deflection member with a first web contacting surface and a second surface opposite the first surface, wherein the web contacting surface comprises a repeating pattern of raised web-contacting elements and deflection conduits, and wherein the web-contacting elements comprise two or more subsets of web-contacting elements, each subset differing from the other subset or subsets in at least one of chemical composition, density, elastic modulus, and storage modulus;
 - e) providing a deformable backing fabric that contacts the second surface of the deflection member;
 - f) providing a compression nip between first and second opposed compression surfaces;
 - g) forming an embryonic web of the papermaking fibers on the foraminous forming member, the embryonic web having a first face and a second face;
 - h) transferring the embryonic web from the foraminous forming member into the compression nip, wherein the first compression surface contacts the deformable backing fabric, which in turn contacts the deflection member, which in turn contacts the embryonic web, which in turn contacts the deformable carrier fabric, which in turn contacts the second compression surface;
 - i) pressing the web in the compression nip wherein a portion of the papermaking fibers in the embryonic web are deflected into the deflection conduits of the deflection member to form a molded web; and
 - j) drying the web.

100. A method of forming a paper web comprising:

- 30
- 35
- a) providing a deformable carrier fabric capable of receiving and containing water pressed from a moist web, the deformable carrier fabric having a web contacting surface and a back surface;
 - b) providing a deflection member with a first web contacting surface and a second surface opposite the first surface, wherein the web contacting surface comprises a repeating pattern of raised asymmetrical web-contacting elements and deflection conduits, the web contacting elements having profiles with nonlinear sides;

- 5 c) providing a moist papermaking web, the web having a first face and a second face, the web residing on one of the web contacting surface of the deflection member or the web contacting surface of the deformable carrier fabric;
- d) providing a deformable material that contacts the second surface of the deflection member;
- e) providing a compression nip between first and second opposed compression surfaces;
- 10 f) pressing the web in the compression nip while the web is in contact with both the deflection member and the deformable backing fabric, and while the deflection member is in contact with the deformable material, to form a molded web; and
- g) drying the web.

15 101. The method of Claim 100, further comprising shearing the web while it is in contact with the deflection member.

102. The method of Claim 101, wherein shearing the web comprises transferring the web from one of the deflection member and the deformable carrier fabric traveling at a first velocity to the other one of the deflection member and the deformable carrier fabric traveling at a second velocity less than the first velocity.

20 103. The method of Claim 100, wherein at least one of the first and second opposed compression surfaces comprises a deformable material.

104. The method of Claim 100, wherein at least one of the first and second opposed compression surfaces comprises a deformable material selected from rubber, a composite comprising rubber, a deformable polymer, an elastomer, and a flexible cover backed with one of a slurry, a liquid, loose particulate material, rubber, a
25 composite comprising rubber, and deformable fibrous matter.

105. The method of Claim 100, wherein at least one of pressing the web and drying the web comprises passing the web through a Condebelt dryer.

106. The method of Claim 100, wherein at least one of pressing the web and drying the
30 web comprises passing the web through an impulse dryer.

107. A method of forming a paper web comprising the steps of:

- a) providing an aqueous dispersion of papermaking fibers;
- b) providing a foraminous forming member;
- c) providing a deformable carrier fabric capable of receiving and containing water pressed from a web;
- 5 d) providing a deflection member with a first web contacting surface and a second surface opposite the first surface, wherein the web contacting surface comprises a repeating pattern of raised web- densifying elements and deflection conduits, and wherein the raised elements comprise two or more subsets of raised elements, each subset differing from the other
- 10 subset or subsets in at least one of chemical composition, density, elastic modulus, and storage modulus;
- e) providing a deformable backing fabric that contacts the second surface of the deflection member;
- f) providing a compression nip between first and second opposed
- 15 compression surfaces;
- g) forming an embryonic web of the papermaking fibers on the foraminous forming member, the embryonic web having a first face and a second face;
- h) transferring the embryonic web from the foraminous forming member into
- 20 the compression nip, wherein the first compression surface contacts the deformable backing fabric, which in turn contacts the deflection member, which in turn contacts the embryonic web, which in turn contacts the deformable carrier fabric, which in turn contacts the second compression surface;
- 25 i) pressing the web in the compression nip wherein a portion of the papermaking fibers in the embryonic web are deflected into the deflection conduits of the deflection member to form a molded web; and
- j) drying the web.

108. The method of Claim 107, further comprising foreshortening the web.

30 109. The method of Claim 108, wherein foreshortening the web comprises creping the web.

110. The method of Claim 108, wherein foreshortening the web comprises a rush transfer operation of the web prior to drying the web.

111. A method of forming a paper web comprising:
- a) providing an aqueous dispersion of papermaking fibers;
 - b) providing a foraminous forming member;
 - c) providing a first dewatering felt capable of receiving and containing water
5 pressed from a web, the first dewatering felt traveling at a first velocity;
 - d) providing a foraminous deflection member having a web contacting face comprising a network web imprinting surface defining a plurality of discrete, isolated deflection conduits;
 - e) providing a second dewatering felt capable of receiving and containing
10 water pressed from a web, the second dewatering felt traveling at a second velocity;
 - f) providing a compression nip between first and second opposed compression surfaces;
 - g) forming an embryonic web of the papermaking fibers on the foraminous
15 forming member, the embryonic web having a first face and a second face;
 - h) transferring the embryonic web from the foraminous forming member to the first dewatering felt to position the first face of the embryonic web adjacent the first dewatering felt;
 - 20 i) positioning the deflection member to be intermediate the embryonic web and the second dewatering felt in the compression nip as the embryonic web remains in contact with the first dewatering felt, such that the second face of the web contacts the web imprinting surface of the deflection member and the first face of the web contacts the first dewatering felt;
 - 25 and
 - j) pressing and shearing the intermediate web in the compression nip to further deflect the papermaking fibers into the deflection conduits to form a molded web.
112. The method of Claim 111, wherein the velocity of the first dewatering felt is
30 substantially greater than the velocity of the second dewatering felt.
113. The method of Claim 111, wherein the deflection member comprises elastomeric material.
114. The method of Claim 111, wherein the deflection member is free of polymeric material photocured by actinic radiation.

115. A method of forming a paper web comprising:
- a) providing an aqueous dispersion of papermaking fibers;
 - b) providing a foraminous forming member;
 - c) providing a first dewatering felt capable of receiving and containing water
5 pressed from a web;
 - d) providing a foraminous deflection member having a web contacting face comprising a network web imprinting surface defining a plurality of discrete, isolated deflection conduits, the conduits characterized by an asymmetrical profile when viewed in a machine direction cross-sectional
10 view passing through the longest machine-direction span of the conduits;
 - e) providing a second dewatering felt capable of receiving and containing water pressed from a web;
 - f) providing a compression nip between first and second opposed compression surfaces;
 - g) forming an embryonic web of the papermaking fibers on the foraminous
15 forming member, the embryonic web having a first face and a second face;
 - h) transferring the embryonic web from the foraminous forming member to the deflection member to position the first face of the embryonic web adjacent the deflection member;
20
 - i) deflecting a portion of the papermaking fibers on the deflection member to form a non-monoplanar intermediate web of the paper making fibers;
 - j) positioning the intermediate web and the deflection member intermediate the first dewatering felt and the second dewatering felt in the
25 compression nip, wherein the first felt is positioned adjacent the first face of the intermediate web, wherein the web imprinting surface of the deflection member is positioned adjacent the second face of the intermediate web; and
 - k) pressing the intermediate web in the compression nip to further deflect
30 the papermaking fibers into the deflection conduits to form a molded web comprising asymmetrical domes.

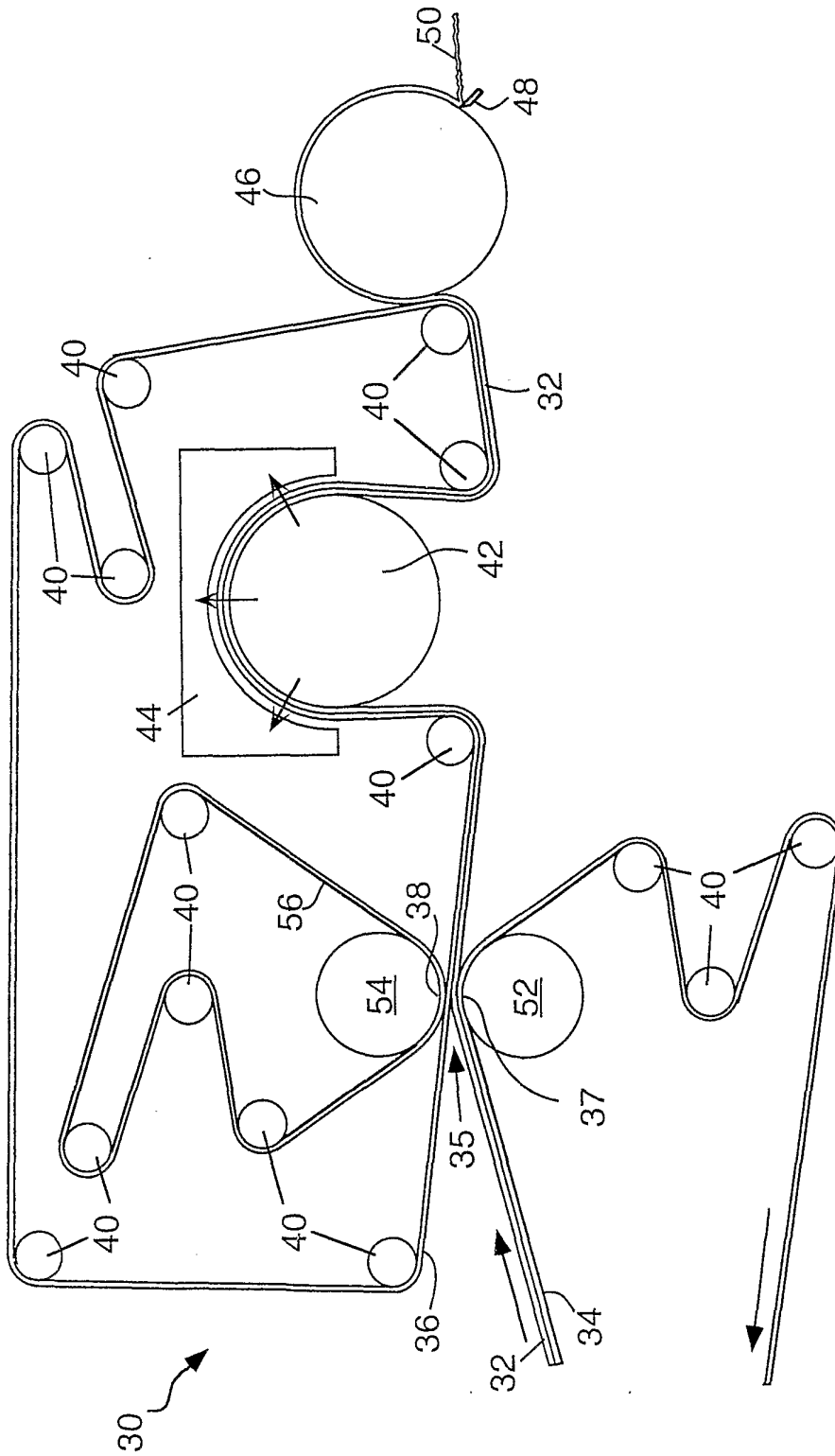

FIG. 1

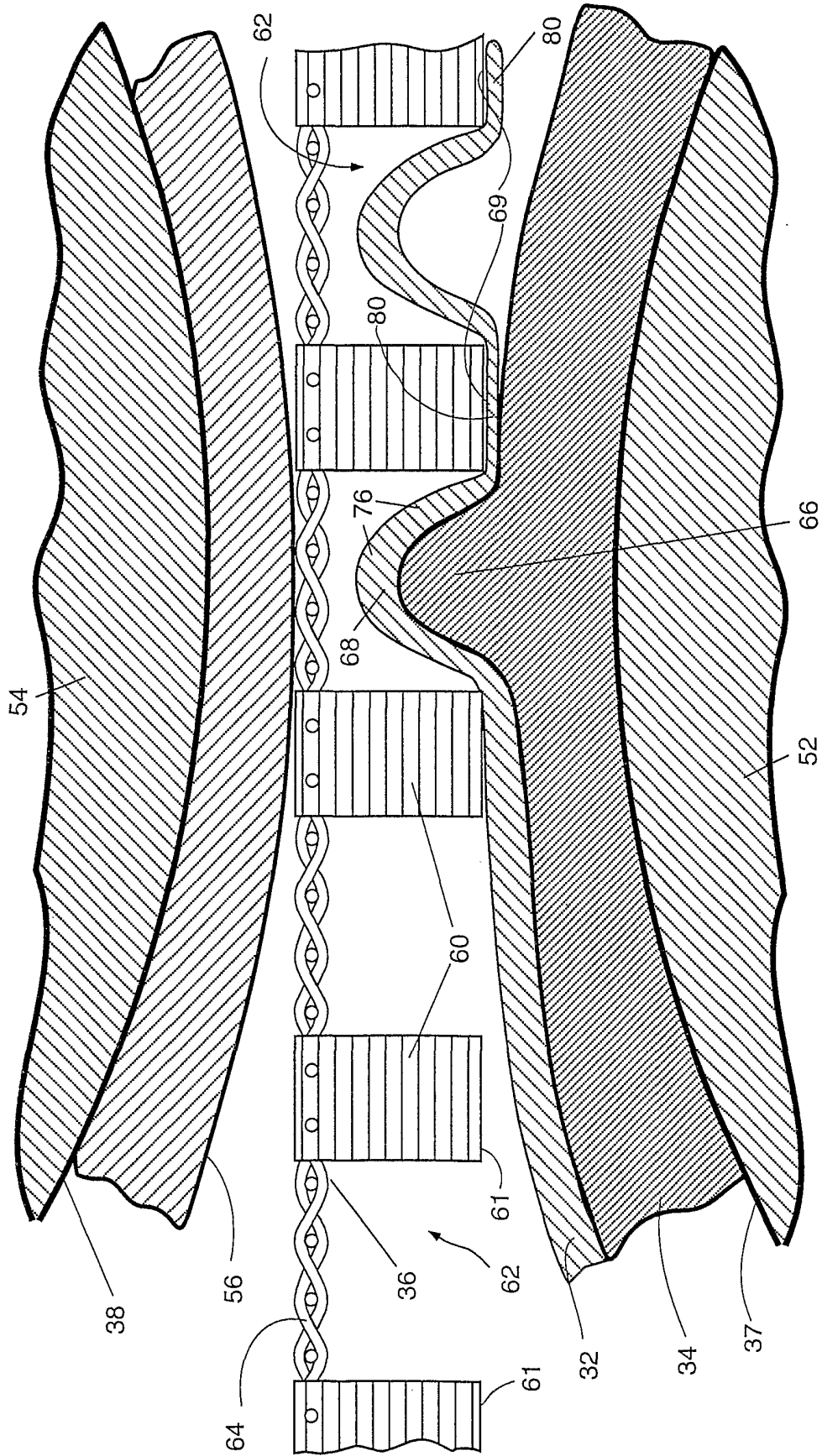

FIG. 2A

3/12

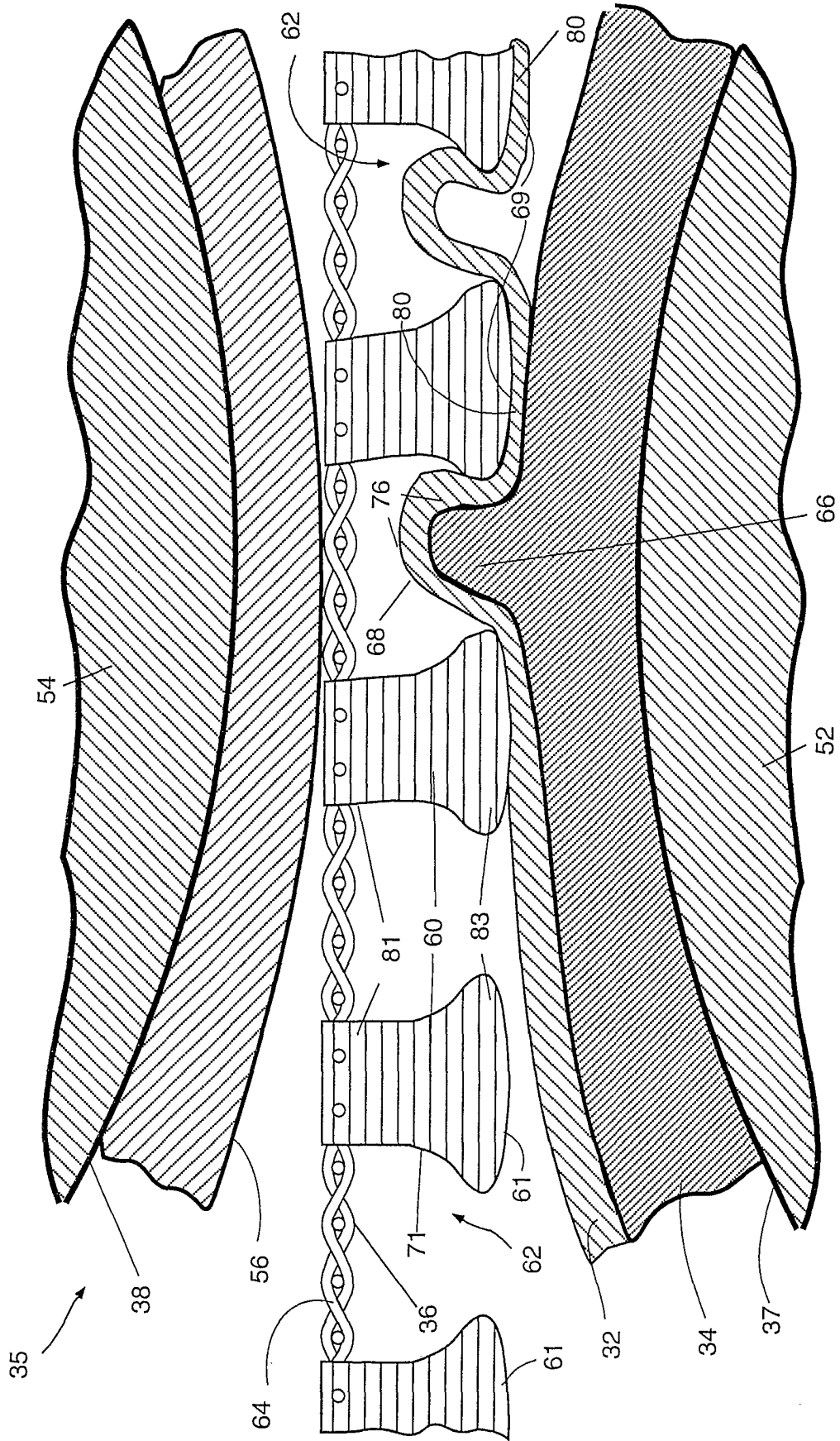

FIG. 2B

4/12

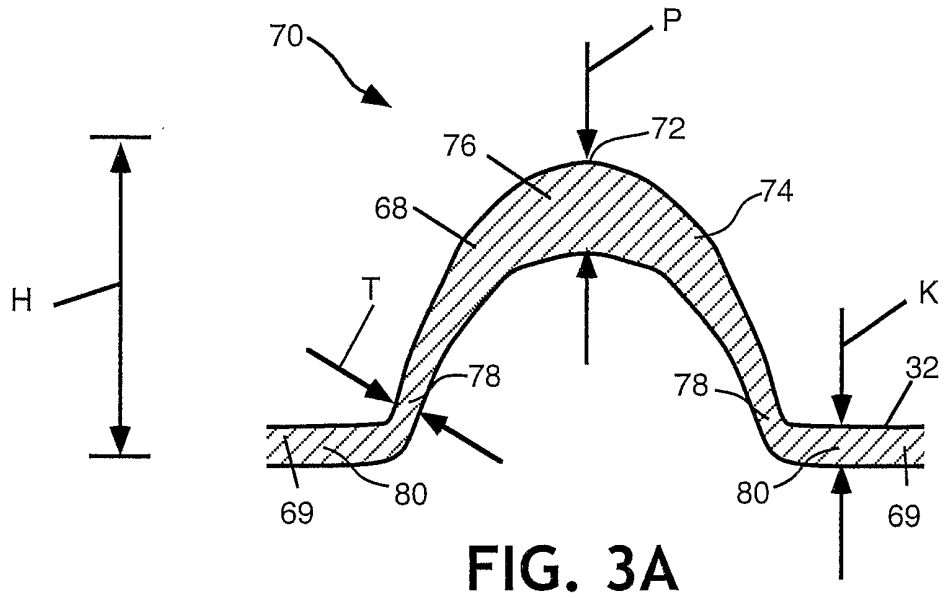

FIG. 3A

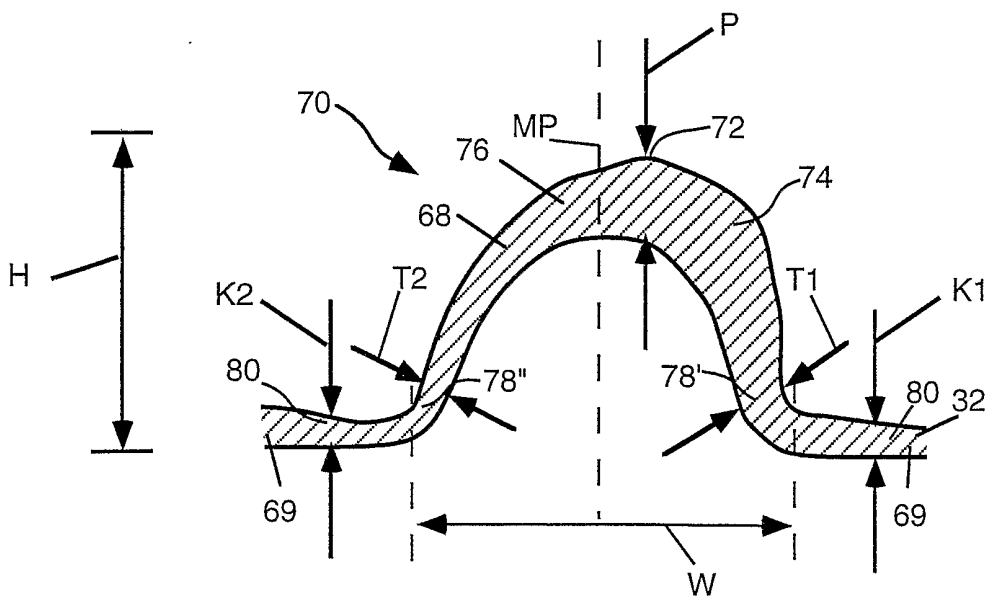

FIG. 3B

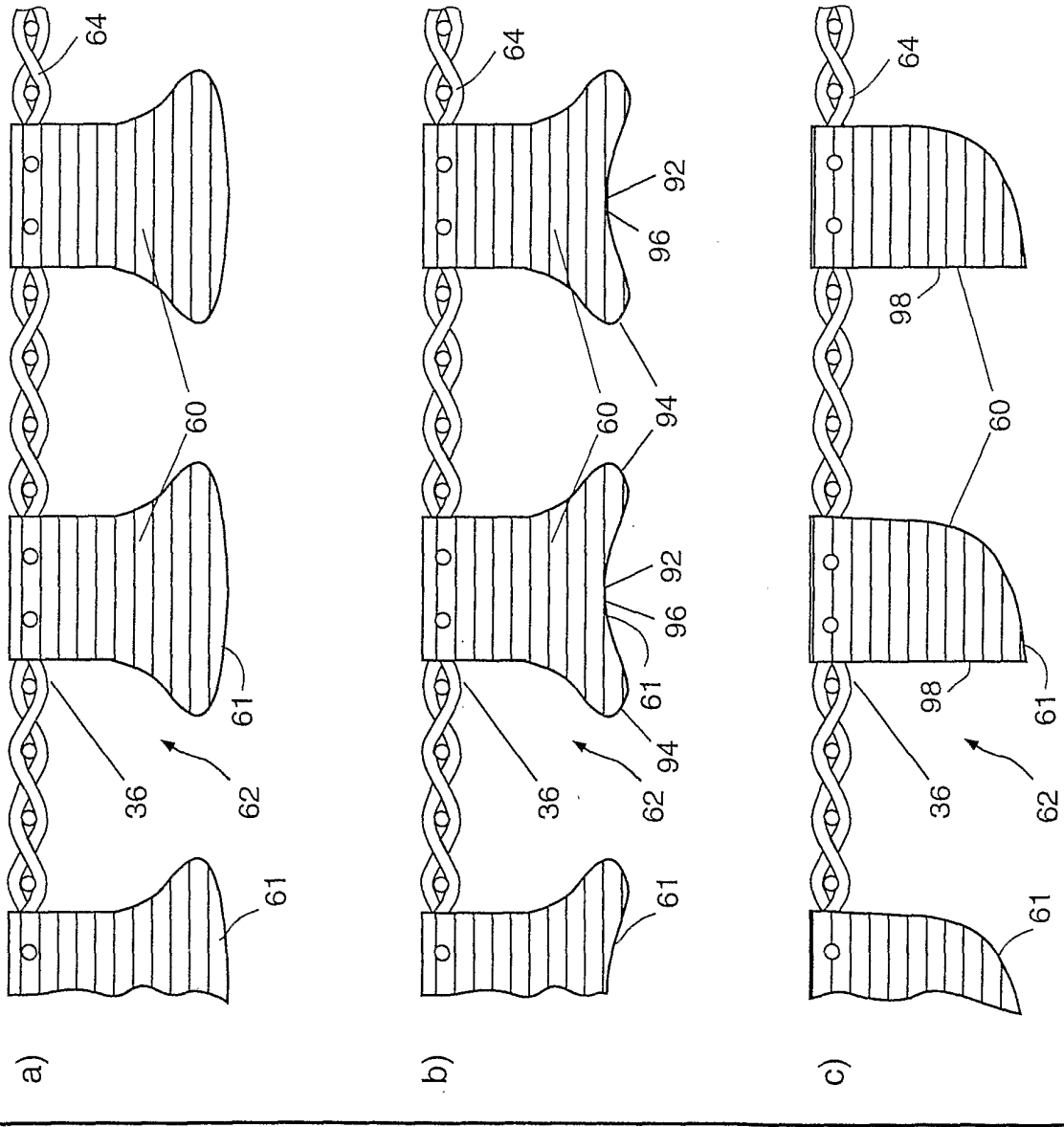

FIG. 4

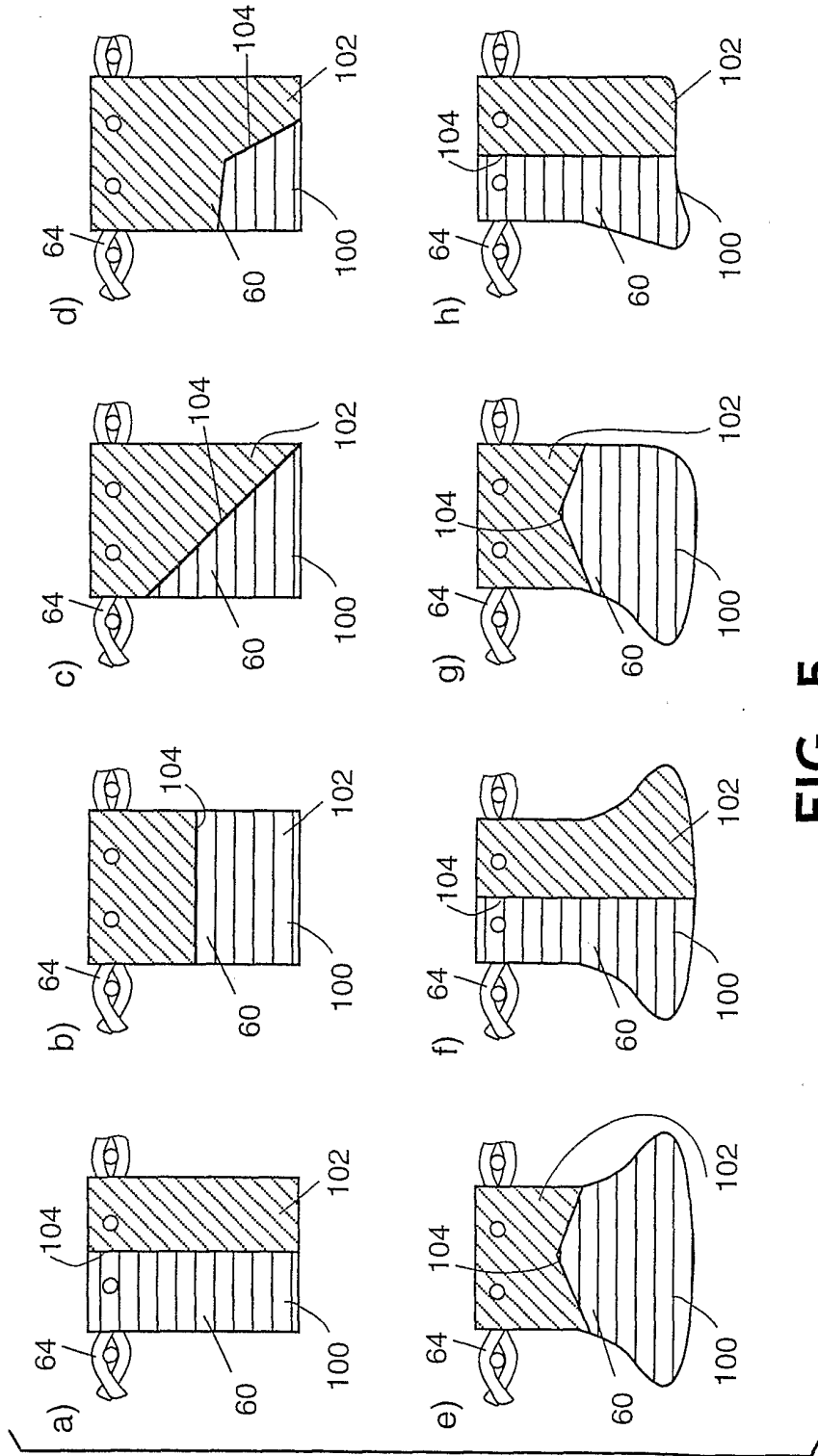

FIG. 5

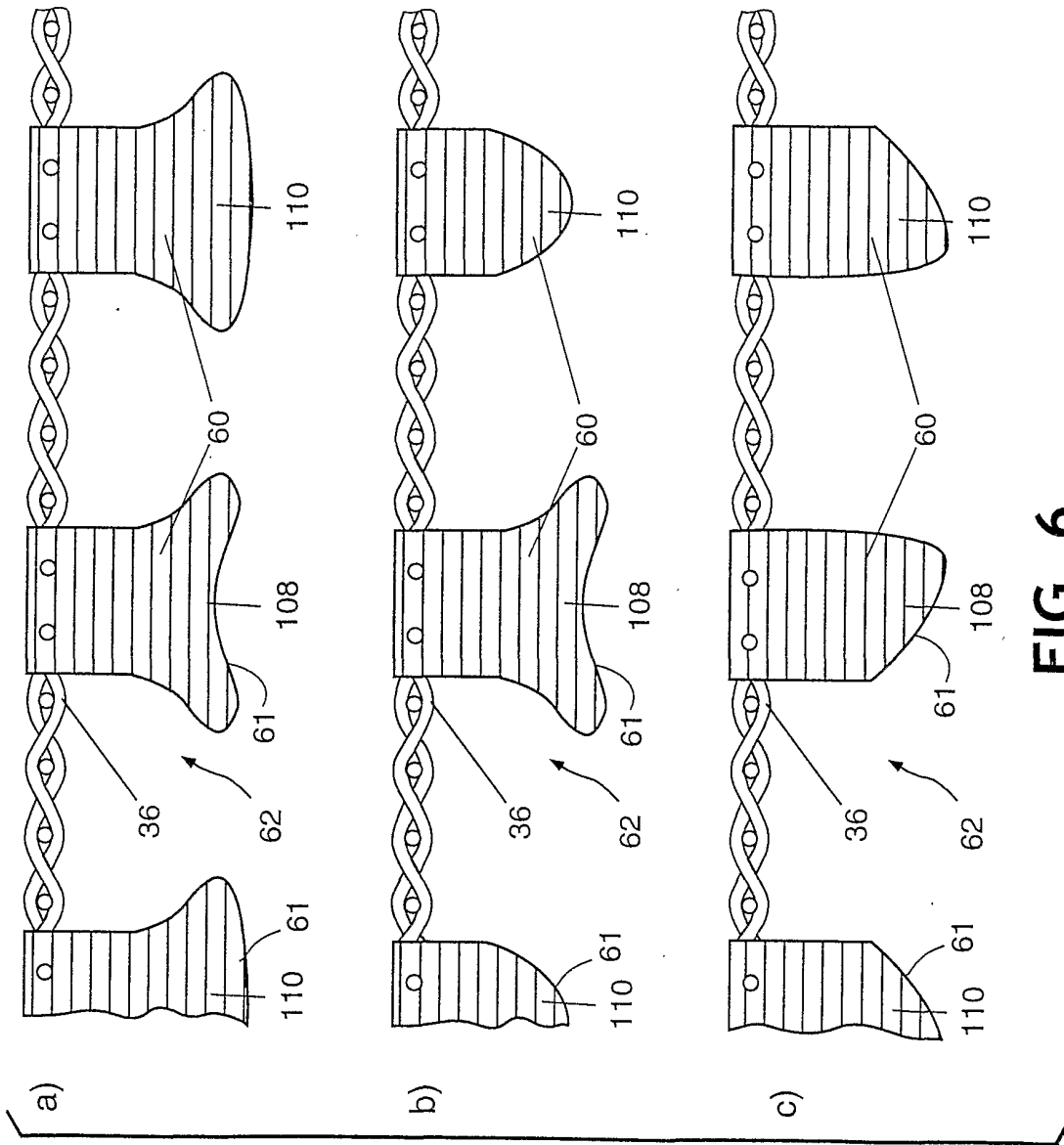

FIG. 6

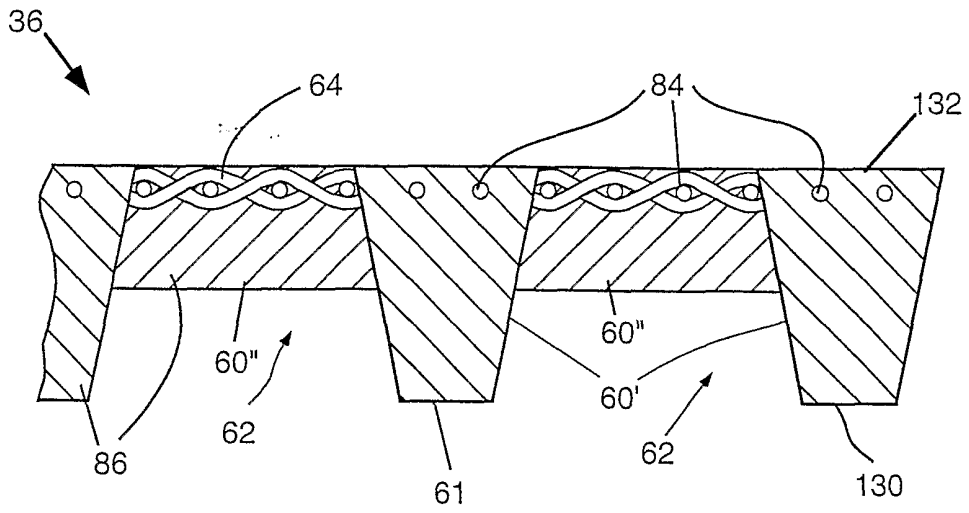

FIG. 7

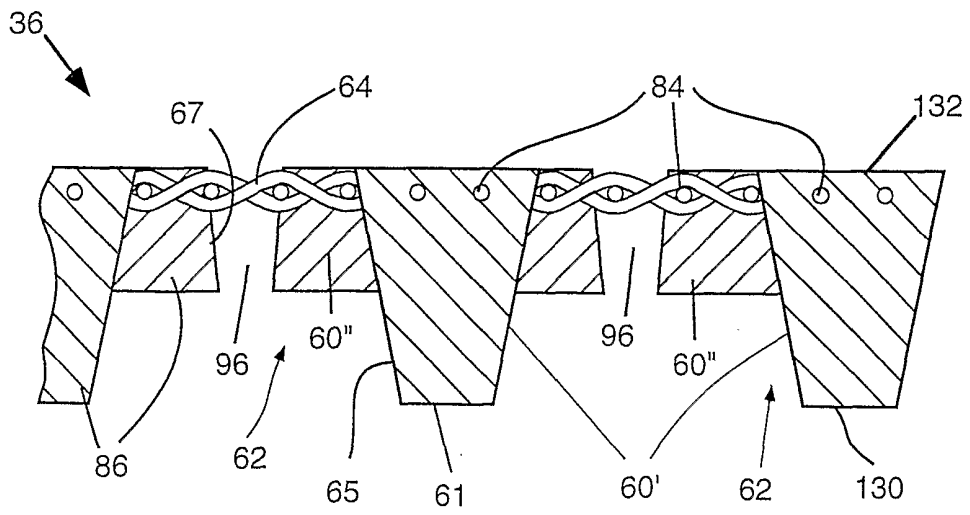

FIG. 8

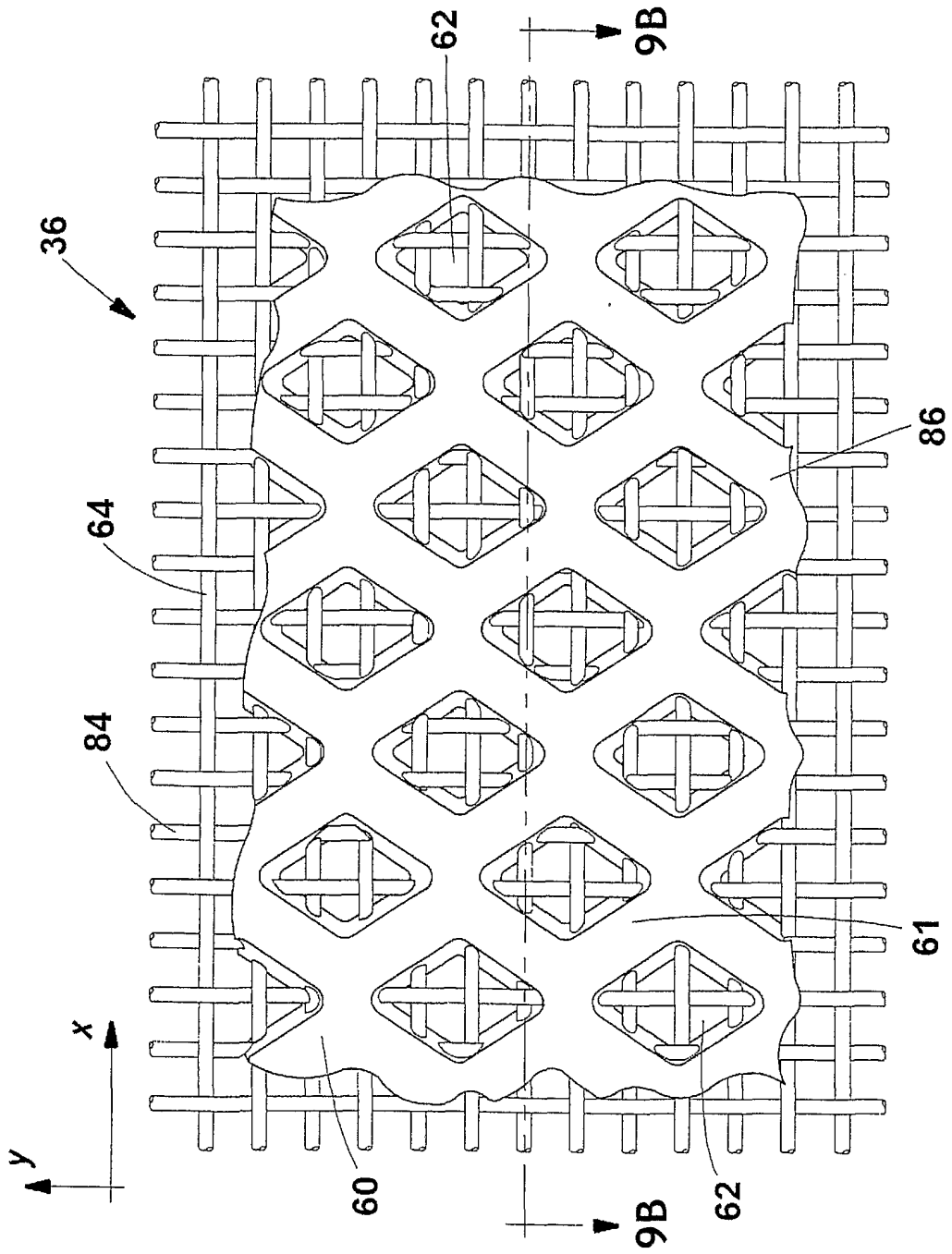

FIG. 9A

10/12

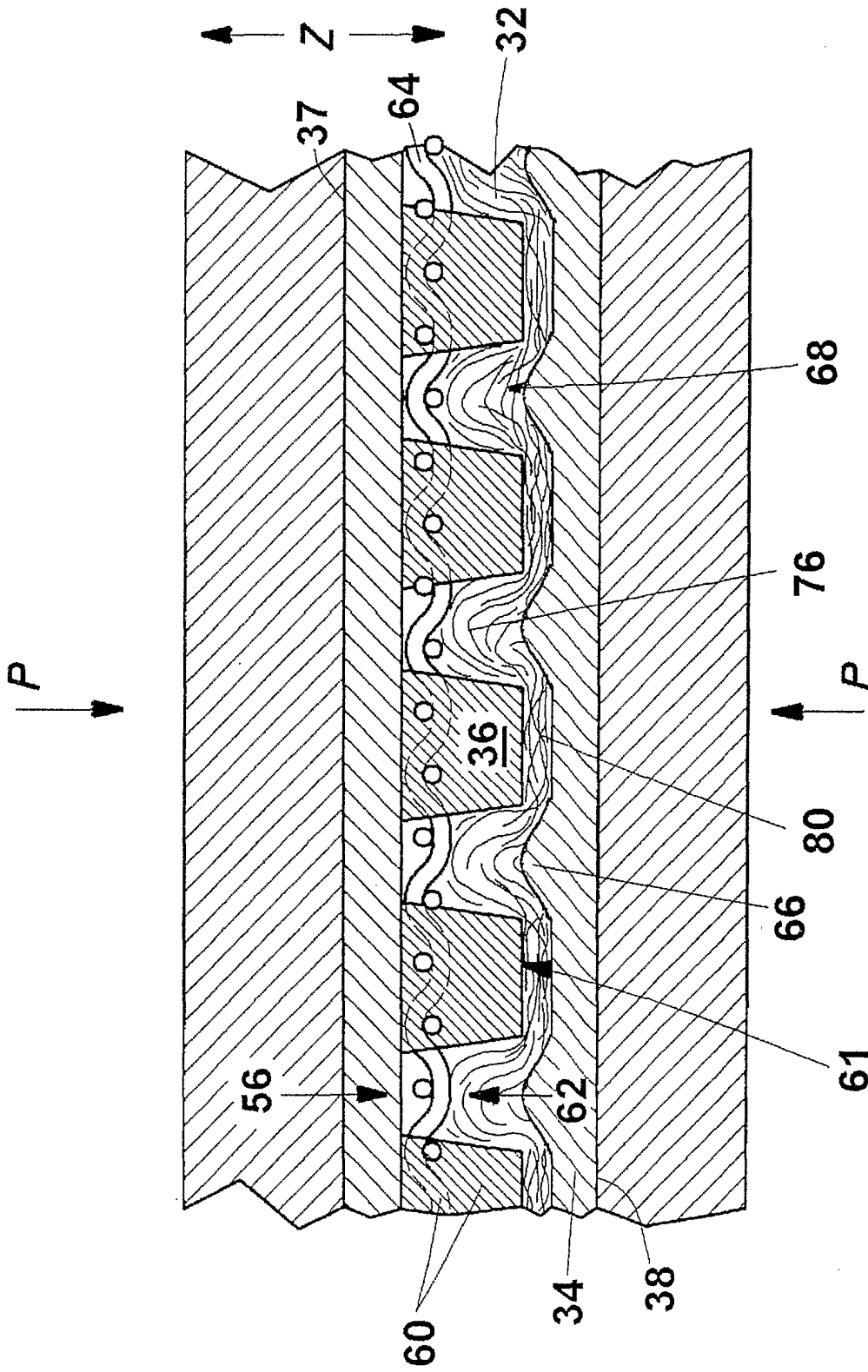

FIG. 9B

11/12

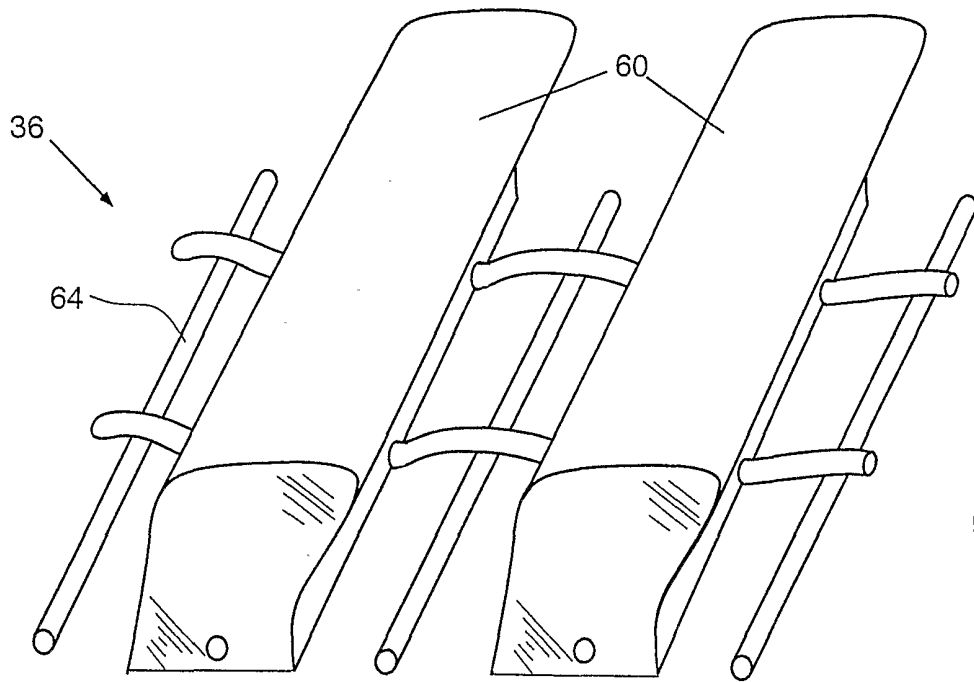

FIG. 10

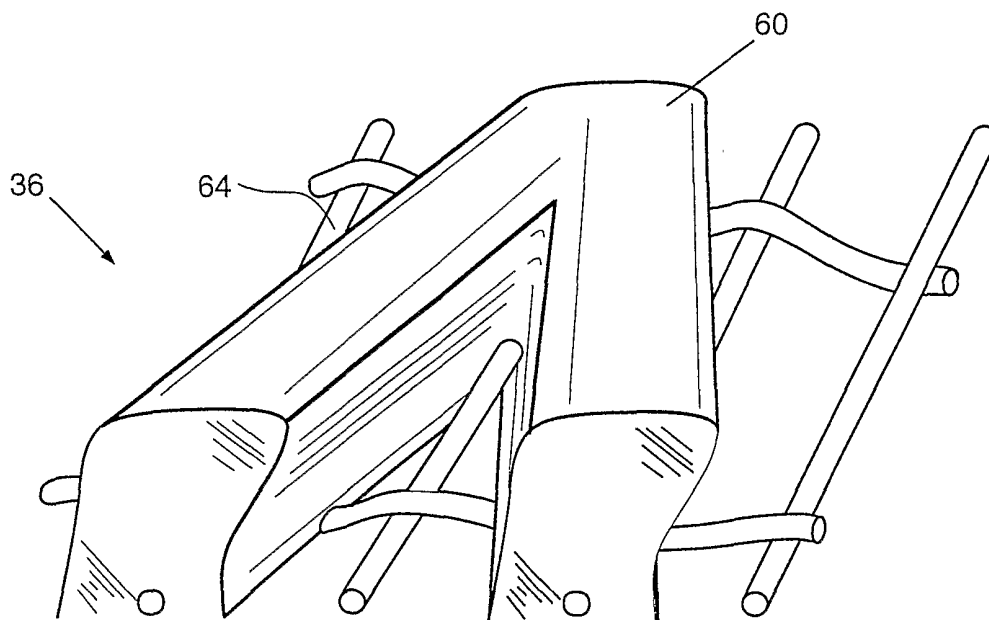

FIG. 11

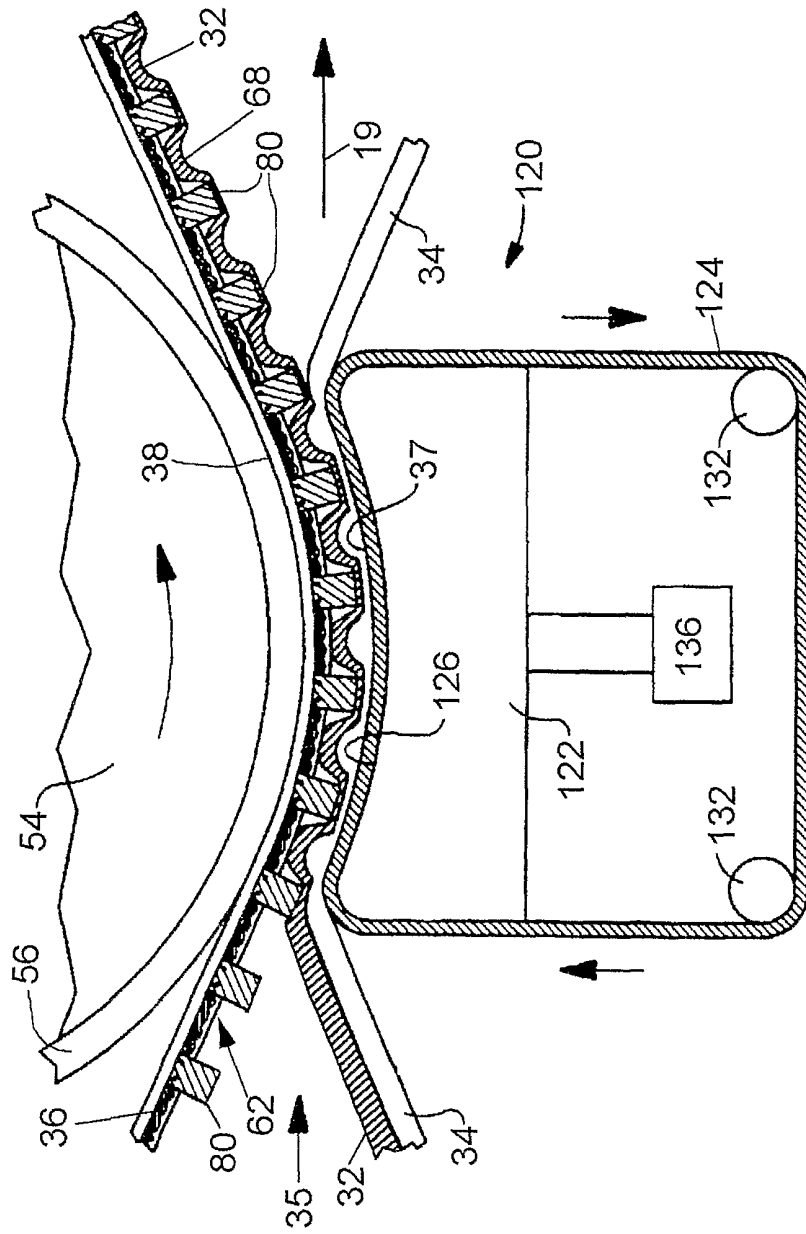

FIG. 12