

Feb. 13, 1945.

H. G. WYSE

2,369,198

MECHANICAL SHAVER

Filed June 13, 1938

Fig.-1

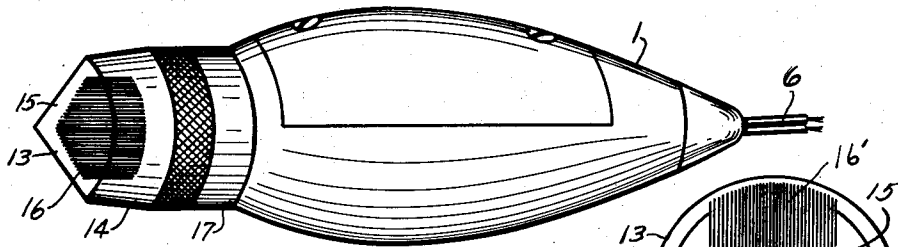

Fig.-9

Fig.-8

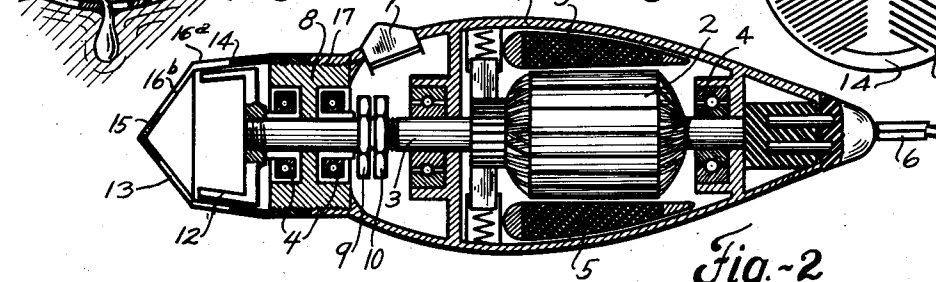
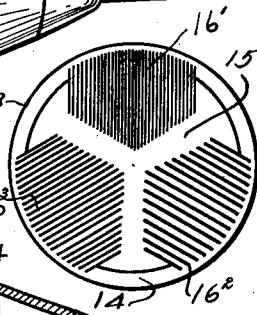

Fig.-2

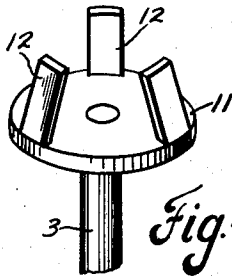

Fig.-3

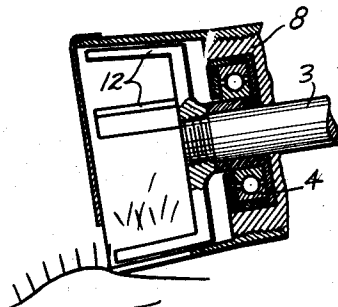

Fig.-5



Fig.-7

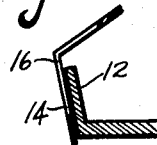

Fig.-6

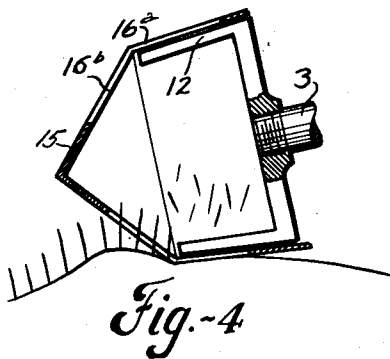

Fig.-4

Inventor

Harold G. Wyse
By J. L. Walker

Attorney

UNITED STATES PATENT OFFICE

2,369,198

MECHANICAL SHAVER

Harold G. Wyse, Dayton, Ohio

Application June 13, 1938, Serial No. 213,338

17 Claims. (Cl. 30-43)

This invention pertains to power operated hair clippers or mechanical razors, and more particularly to a dry shaver or "electric" razor of the rotary type and the mode of operation thereof.

Heretofore, sundry forms of mechanical shavers have been devised wherein the cutter member is subject to rapid reciprocatory, vibratory or rotary motion relative to a cooperating comb or slotted guard member while in contact engagement therewith to effect definite shearing action upon hairs entering the slots of the guard. In such assemblies the cutter and guard elements are subject to excessive wear, become unduly heated while in use as result of friction between such parts, necessitate high power consumption, are noisy in operation, transmit vibrations, and possess other objectionable features.

The rotary shaver forming the subject matter hereof is designed to obviate such undesirable factors and while it may be adjusted to afford similar shearing action between the rotor and guard, it is preferably operated on a somewhat different principle wherein the rotor is given slight clearance relative to the guard whereby it may rotate freely without friction or development of heat with less power requirement, and will sever the engaged hairs by pinching or squeezing them off between the rapidly rotating member and the guard, with increased beneficial effect upon the remaining hair stub.

The object of the invention is to simplify the construction as well as the means and mode of operation of dry shavers or mechanical razors whereby they may not only be economically manufactured, but will be more efficient in use, uniform in action, of increased durability, having minimum parts and unlikely to get out of repair.

A further object of the invention is to provide an improved method of severing engaged hairs by pinching or squeezing action whereby the remaining hair stub will be closed or sealed at its end.

A further object of the invention is to provide coating rotor and guard elements of improved form and shape wherein the entry of hairs into the operative range of the instrument is greatly facilitated.

A further object of the invention is to provide relatively adjustable coating hair severing elements whereby they may be readily and quickly adjusted according to the character and thickness of the hair to be cut, and to enable the instrument to be adjusted at will for either shearing or pinching hair severing action.

A further object of the invention is to provide

a rotor element of improved form and efficient design.

5 A further object of the invention is to provide an improved form of slotted guard or comb of such shape as to present the hair in most advantageous relation for severing closely to the skin.

A further object of the invention is to provide a power shaver which may be used with increased safety, and wherein the skin is amply protected against abrasion, cutting or other injury.

10 A further object of the invention is to provide improved means for adjusting the cooperating elements for different conditions of use.

15 A further object of the invention is to provide a power operated shaver of convenient shape, compact construction and pleasing appearance.

20 A further object of the invention is to provide a mechanical razor having the herein mentioned advantageous structural features and meritorious characteristics.

25 With the above primary and other incidental objects in view as will more fully appear in the specification, the invention intended to be protected by Letters Patent consists of the features thereof, and the mode of operation, or their equivalents, as hereinafter described or illustrated in the accompanying drawing.

30 In the drawing, wherein is shown the preferred but obviously not necessarily the only form of embodiment of the invention,

Fig. 1 is a perspective view of the mechanical shaver forming the subject matter hereof.

35 Fig. 2 is a longitudinal sectional view through the assembled instrument.

Fig. 3 is a detail perspective view of the rotor member.

40 Fig. 4 is an enlarged sectional view of the head of the instrument showing the relation of the rotor and guard elements to each other and to the hairs being severed.

Fig. 5 is a similar detail sectional view of a modified form of operating head.

45 Figs. 6 and 7 illustrate further variations of the shape of the guard and cooperating rotor.

Fig. 8 is an end view of the guard cap.

Fig. 9 is a diagrammatic view illustrating the severance of the hair by pinching action.

50 Like parts are indicated by similar characters of reference throughout the several views.

In the drawing 1 indicates the handle of the instrument, which is shaped to conveniently and comfortably fit the hand of the user, and which also duo-functionally forms the housing or casing for the actuating motor. The motor may be

of any suitable type or construction. That illustrated includes an armature 2, the shaft 3 of which is mounted in anti-friction bearings 4 within the handle or housing 1, which in this instance further comprises the stator or field member of the motor upon which the field windings 5 of the motor are mounted.

Electric current is supplied in the usual manner through a flexible conductor cord or cable 6 and is controlled by a thumb switch 7 projecting from the housing.

The housing 1 is terminated in an externally screw threaded neck 8 in which certain of the shaft bearings 4 are located. These bearings, which are conventional anti-friction ball bearings, are seated in recesses in the opposite faces of the neck portion 8 of the housing, beyond which the inner races or cones of the bearings preferably, although not necessarily, project. A collar 9 adjustably screw threaded upon the shaft for abutting engagement with the inner bearing member and secured in adjusted position by a lock nut 10 limits axial adjustment of the shaft.

Demountably secured upon the shaft beyond the screw threaded neck 8 is the active hair severing member which comprises a rotary disk like head 11 from which project one or more peripherally spaced fingers 12 in angular relation to the plane of rotation of the head 11. The preferable relation of the fingers 12 is that shown in Figs. 2 and 3 wherein the hair engaging fingers converge. However, they will operate equally as effectively when disposed in diverging relation as in Figs. 5 and 6, and are successfully operable when in perpendicular relation as in Fig. 7. In the drawing three such hair impacting fingers are shown, although they may be of greater or less number. In practical demonstrations heretofore, two such fingers 12 have been found amply sufficient.

The rotor 11 preferably abuts upon the inner bearing element of one of the anti-friction bearings 4 to limit the axial movement of the shaft in opposition to the collar 9.

Adjustably mounted upon the screw threaded neck 8 of the housing and enclosing the rotor, beyond which its slotted area extends, is a slotted guard cap 13. The cap is preferably of a double angular form comprising an initial conical section 14 agreeing with the angularity of the fingers 12 and within which the rotor operates. Therebeyond the cap 13 is conically contracted more abruptly at 15. The slotted area 16 of the cap extends beyond the juncture of the respective conical sections 14 and 15 of different angularity, with the portion 16^a within the conical section 14 intersecting the plane of rotation of the rotor, and the portion 16^b within the conical section 15 extending beyond the range of operation of the rotor. While the cap may be slotted throughout its entire periphery, such is not necessary and the slotted portion 16 may be restricted to a comparatively limited area. For convenience several such areas 16¹, 16², 16³, are provided at different radial positions about the circumference of the cap.

By means of the screw threaded adjustment of the cap upon the threaded neck 8, the relation of the conical wall 14 of the cap and the fingers 12 of the rotor may be varied. The cap is fixedly secured in its adjusted position by a lock collar 17 also threaded on the neck 8 of the housing and abutting on the base margin of the cap.

By retracting the cap relative to the rotor, the fingers 12 may be made to contact the interior

surface of the portion 14 thereof whereby they perform a shearing action in cooperation with the edges of the slots 16. However, it is preferred to back off the cap slightly from such contact position whereby approximately a one half thousandth (.0005) of an inch clearance is afforded between the rotating fingers 12 and the interior face of the cap. By this adjustment friction is obviated between such surfaces and the tendency to heat is avoided, as is also excessive wear and noise.

A human hair is ordinarily two to three thousandths (.002 to .003) of an inch in diameter. Hence the clearance of a one half thousandth is too minute to permit a hair to pass through, and as result the hair is forcibly squeezed or pinched off between the finger 12 and the side of the cap or guard slot.

It is quite common practice to singe the ends of the hair after cutting to close the channel. The present pinching or squeezing severing operation serves to close the end of the hair stub in somewhat similar manner.

Microscopic examination shows that the result of the present hair severing action is materially different from ordinary shaving methods. A hair cut by a conventional type of razor shows an acutely tapered or beveled terminal end. One cut by a more recent mechanical vibratory shaver wherein a shearing action is effected leaves a square, blunt end substantially perpendicular to the axis of the hair. The present pinching action leaves a rounded terminal wherein the hair seems to be uniformly contracted into a substantially semi-spherical end, with sometimes a minute teat or sprue at the extreme top of its terminal curvature.

It has been found that after shaving with the present device of the growth of the beard does not again start so quickly as when other mechanical shavers or an ordinary razor is used.

The fingers of the rotor being spaced relatively wide apart afford sufficient interval for the hair to enter well within the field of operation preparatory to being severed. To provide further lag or increased interval the fingers may be unequally spaced and the rotor head suitably counterbalanced, or they may be reduced in number to a single finger. In using the vibratory type shavers now available it is found that the spacing or pitch of the slotted guard ordinarily employed must be proportioned to the type and coarseness of the beard to be shaved. The same pitch or spacing does not work equally well on all beards. Guards of different pitch must be interchanged and tried until one of suitable character is found.

To provide a universal instrument, the guard cap of the present shaver is preferably, although not necessarily, provided with multiple slotted areas 16¹, 16², 16³, having slots of different width and spacing to accommodate beards of different character, including those which are coarse and others which are fine and those which are stiff and hard to cut, and others which cut easily. To find the pitch or spacing of the guard slots most suitable it is only necessary to turn the instrument through a partial rotation to bring different slotted area in contact with the face. The angular side walls of the conical cap beyond the juncture of which the slotted areas extend greatly facilitate the entry of the hairs into the slots and thence into the range of operation of the rotor. The fact that the rotor has clearance inside the guard cap and does not wipe across

the slots with shearing action necessitates less power for operation, or conversely affords increased power for hair severing operation and at the same time obviates friction and its resulting heat and wear upon the parts. Likewise, the non-contacting relation of the rotor and guard cap results in quiet operation and the coating edges do not become dulled even after long use. The construction is such that the operative parts may be quickly and accurately adjusted without special tools and by one unskilled in mechanical arts, and of such sturdy character that it will readily withstand hard usage without injury or deterioration.

From the above description it will be apparent that there is thus provided a device of the character described possessing the particular features of advantage before enumerated as desirable, but which obviously is susceptible of modification in its form, proportions, detail construction and arrangement of parts without departing from the principle involved or sacrificing any of its advantages.

While in order to comply with the statute the invention has been described in language more or less specific as to structural features, it is to be understood that the invention is not limited to the specific features shown, but that the means and construction herein disclosed comprise the preferred form of several modes of putting the invention into effect, and the invention is therefore claimed in any of its forms or modifications within the legitimate and valid scope of the appended claims.

Having thus described my invention, I claim:

1. In a mechanical shaver, an apertured guard element of truncated conical form, a rotor mounted in concentric relation therewith including a sweep finger inclined to the axis of rotation in parallel closely adjacent spaced relation with the interior wall of the conical guard, and adjusting means for positively adjusting said sweep finger axially relative to the slotted guard element, and locking means for maintaining the zone of rotation of the sweep finger and guard element in their adjusted relation.

2. A mechanical shaver including a circular tapered slotted guard and a rotary sweep mounted in concentric closely adjacent spaced relation interiorly thereof correspondingly inclined to the axis of the tapered guard traversing the slots of the guard in its rotation, and means for effecting positive axial adjustment of the rotary sweep relative to the guard and for maintaining the field of operation of the sweep and the guard in their relatively adjusted relation.

3. In a rotary mechanical shaver, a rotary sweep and a circular cap within which the sweep rotates in relatively spaced relation thereto, including angularly intersecting surfaces both being inclined to the axis thereof said cap having therein a series of parallel slots extending across the intersection of said angularly disposed surfaces from within the zone of rotation of the sweep to points removed therebeyond.

4. A guard element for a mechanical shaver including a circular cap formed with two angularly disposed intersecting conical surfaces of different inclination to the axis of the cap, said cap having therein a series of slots extending in opposite axial directions across the juncture of said conical surfaces into both said surfaces, and a hair severing member mounted in closely adjacent relation with the slots on one side of the juncture of said conical surfaces.

5. In a mechanical shaver, an apertured double conical guard element having therein plural groups of apertures of different dimensions to accommodate hairs of different characteristics, a traveling hair severing element mounted concentrically with the guard element for relative motion in parallel closely adjacent but non-contacting relation therewith, the hair severing element being operative relative to the guard and common to the plural groups of apertures therein.

6. In a mechanical shaver, an apertured double conical guard member having therein different groups of apertures of different characteristics, and a traveling hair severing member mounted concentrically with the guard element for relative motion in parallel closely adjacent but non-contacting relation therewith and cooperative with the guard member to sever hairs projected through the apertures thereof and common to the different groups of apertures of different character which are optionally selective for shaving operation.

7. In a mechanical shaver, an apertured guard element having therein grouped apertures of sorted widths to accommodate hairs of different characteristics, and a traveling hair severing element mounted for relative motion in parallel closely adjacent but relatively spaced relation with the guard element and common to the apertures of different sizes and operable by motive means, said grouped apertures being of different sizes which are optionally selective for shaving operation.

8. In a mechanical shaver, a circular cup-shaped guard member having therein a series of slots extending in parallel generally axial direction, and a rotary sweep concentrically mounted interiorly of the guard member for rotary motion transversely of said slots in a relatively fixed zone of rotation, said guard member and slots therein extending beyond the zone of rotation of the sweep in a direction inclined thereto through which slot extensions hairs to be cut may pass into the zone of operation of said sweep.

9. In a mechanical shaver, a conical apertured guard member presenting angularly related apertured faces for contact with the surface to be shaved and wherein the apertures extend across and in opposite directions from the juncture of such angular faces, and a rotary hair severing member correspondingly inclined to its axis of rotation for relative travel motion in closely adjacent parallel non-contacting relation with the conical apertured guard, the apertures in one of said angular faces being beyond the zone of operation of said hair severing member and through which hairs to be severed pass from said first angular face to the other and into the zone of operation of the hair severing member contiguous thereto, the rotary hair severing member having motive means therefor, and adjusting means for positively adjusting the rotary hair severing member and the conical apertured guard member axially one relative to the other to vary their spaced relation and to maintain said members in their non-contacting relation with each other.

10. The herein described method of using mechanical shaving devices including the step of relatively adjusting guard and hair severing elements into closely adjacent non-contacting relation for rapid travel motion one relative to the other by which engaged hairs are pinched off between said members.

11. In a mechanical shaver, a slotted guard

member presenting angularly related apertured faces for contact with the surface to be shaved and wherein the slots extend across and in opposite directions from the juncture of such angular faces, and a traveling hair severing member operative in parallel relation with the slotted area of the guard at one side of the juncture of said angular faces, the slots continuing at one side of the juncture of said angular faces entirely beyond the zone of operation of said hair severing member and through which hairs to be cut may pass from one angular face of the guard member into the zone of operation of the hair severing member contiguous to the other face thereof.

12. In a mechanical shaver, a recessed handle having at one end thereof a screw threaded terminal, a rotary shaft having motive means therefor mounted within the handle concentrically with the screw threaded terminal, a rotor carried by the shaft in juxtaposition to the screw threaded terminal, a sweep finger eccentrically carried by the rotor and extending in inclined relation to the axis of rotation of the rotor, a guard cap having screw threaded adjustable engagement on the screw threaded terminal of the handle, said cap including a slotted conical portion the angularity of which substantially agrees with that of the sweep finger, in the zone of the slotted area of which the sweep finger rotates, said cap including a continuing conical portion of increased angularity to the axis of rotation of the rotor into which the slots of the initial portion are extended beyond the zone of operation of the sweep finger, the cap and sweep finger being relatively adjustable into and out of contacting relation by the screw threaded adjustment of the cap on the threaded terminal of the handle and means for locking the cap in its position of adjustment relative to the sweep finger.

13. A guard element for a mechanical shaver substantially circular in cross section and having therein a plurality of groups of apertures of different dimensions selectively usable when shaving hairs having different characteristics, and a traveling hair severing element mounted concentrically with the guard element for relative motion in parallel closely adjacent but non-contacting relation therewith.

14. A guard element for a mechanical shaver, comprising a circular cap having side walls which are unaligned in an axial direction and having therein a plurality of slots in one of the unaligned

side wall portions extending thence into another of the unaligned side wall portions of the cap, and a hair severing element coacting with one of the unaligned side wall portions of the cap, so constructed and arranged that hairs entering within the slots in one of said unaligned wall portions of the cap beyond the zone of operation of the coacting hair severing element may pass thence into the slots in the other of said unaligned wall portions and into the zone of operation of the hair severing element.

15. In a mechanical shaver, an apertured conical guard element, a support on which the guard element is mounted and with respect to which the guard element is axially adjustable, a member carried by the support and cooperating with the apertured guard element to sever hairs by a pinching action, said member including a rotor concentrically positioned within the guard element and having a sweep finger traveling in parallel relatively spaced relation with the apertured area of the guard element, the construction and arrangement being such that adjustment of the guard element relative to the support varies the spacing between the interior wall of the guard element and the sweep finger.

16. In a mechanical shaver, an apertured conical guard element, a support on which the guard element is mounted, a member carried by the support and cooperating with the apertured guard element to sever hairs by a pinching action, said member including a rotor having a sweep finger traveling in parallel relatively spaced relation with the apertured area of the guard element, and means for relatively adjusting the guard element and the sweep finger to vary the spacing therebetween.

17. In a mechanical shaver, an apertured conical guard element, a support on which the guard element is mounted and with respect to which the guard element is axially adjustable, a member carried by the support and cooperating with the apertured guard element to sever hairs by a pinching action, said member including a rotor concentrically positioned within the guard element and having a sweep finger traveling in parallel relatively spaced relation with the apertured area of the guard element, the construction and arrangement being such that relative axial adjustment of the guard element and sweep finger varies the spacing between the interior wall of the guard element and the sweep finger.

HAROLD G. WYSE.

CERTIFICATE OF CORRECTION.

Patent No. 2,369,198.

February 13, 1945.

HAROLD G. WYSE.

It is hereby certified that error appears in the above numbered patent requiring correction as follows: In the grant, line 1, name of inventor, for "HARLOD" read --HAROLD--; page 3, first column, line 58, claim 3, after the word "sweep" first occurrence, insert --having actuating means therefor,--; line 61, same claim, after "thereof" insert a comma; and that the said Letters Patent should be read with this correction therein that the same may conform to the record of the case in the Patent Office.

Signed and sealed this 26th day of June, A. D. 1945.

Leslie Frazer

(Seal)

Acting Commissioner of Patents.