

(No Model.)

3 Sheets—Sheet 1.

C. P. BROWN. MUSIC LEAF TURNER.

No. 527,658.

Patented Oct. 16, 1894.

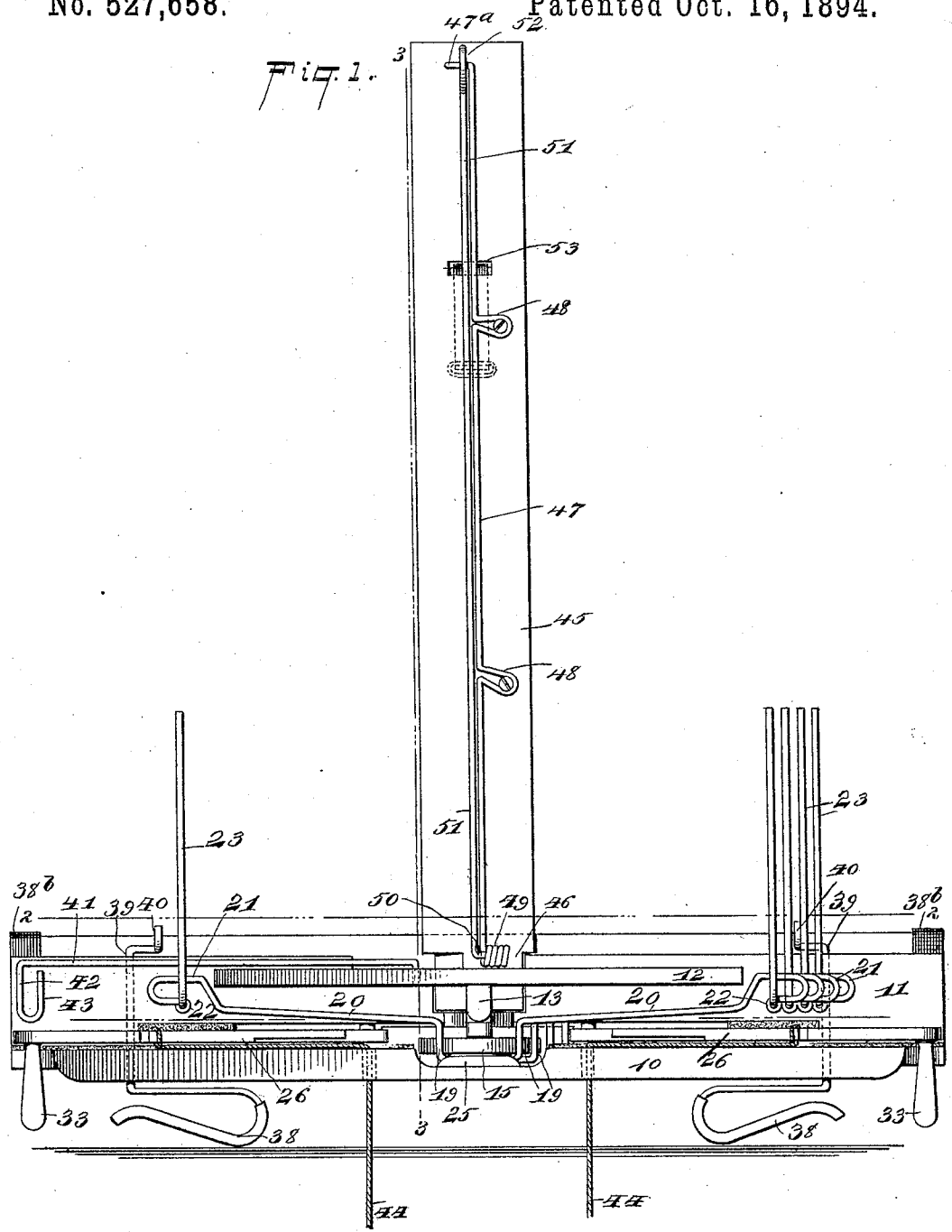

WITNESSES:
William Goebel.
C. Sedgwick

INVENTOR
C. P. Brown
 BY *Munn & Co*

ATTORNEYS.

C. P. BROWN.
MUSIC LEAF TURNER.

No. 527,658.

Patented Oct. 16, 1894.

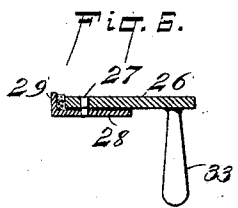
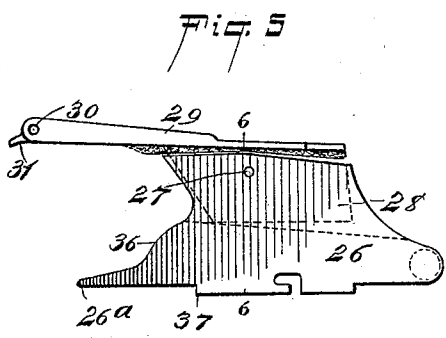
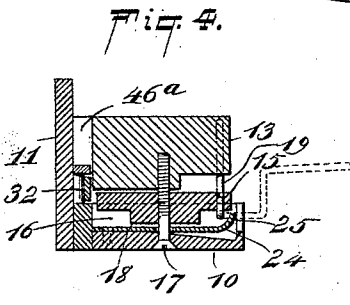
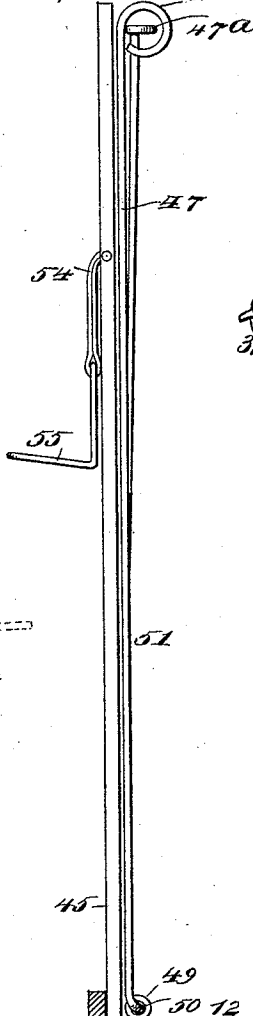
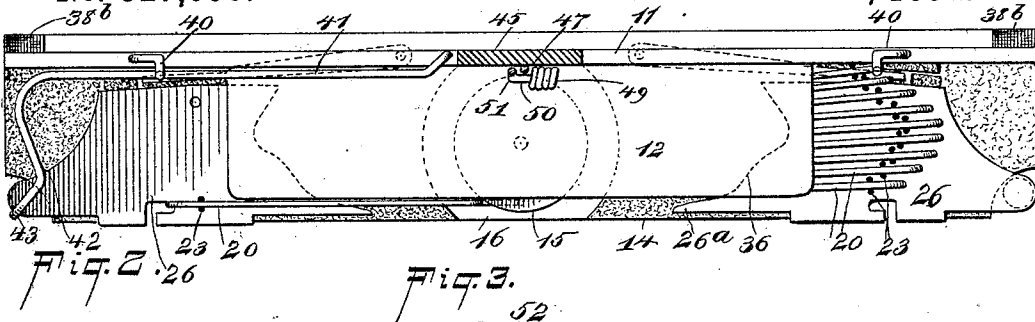

WITNESSES:
William Goebel.
L. Sedgwick

INVENTOR
C. P. Brown
 BY *Munn & Co*
 ATTORNEYS.

(No Model.)

3 Sheets—Sheet 3.

C. P. BROWN,
MUSIC LEAF TURNER.

No. 527,658.

Patented Oct. 16, 1894.

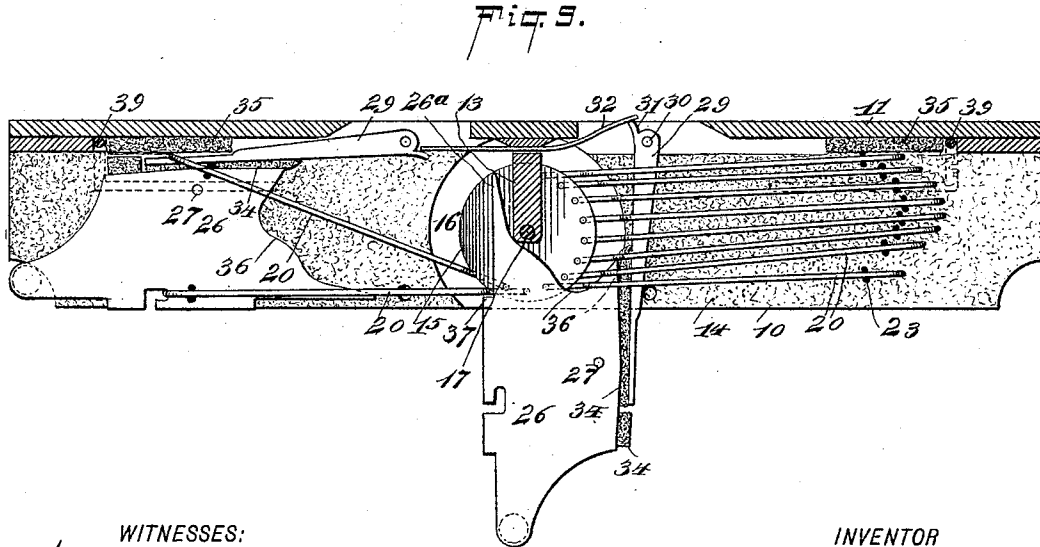
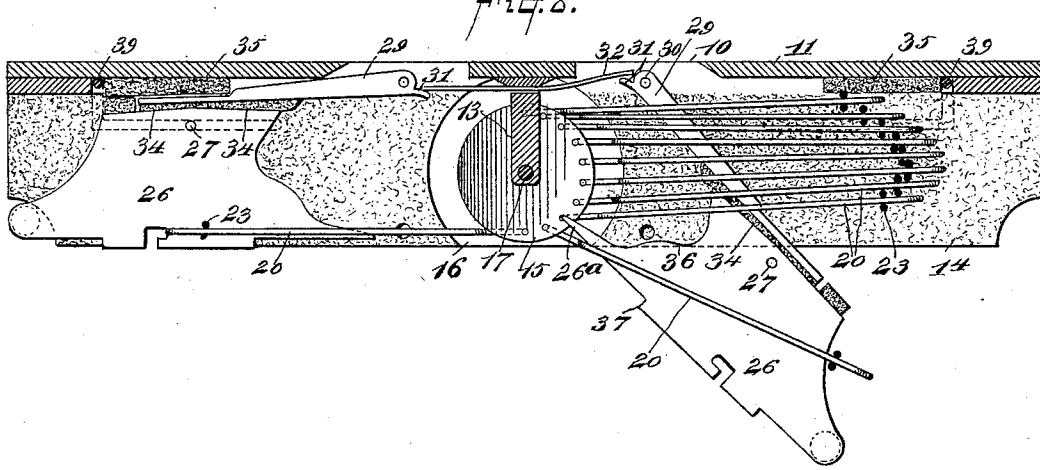
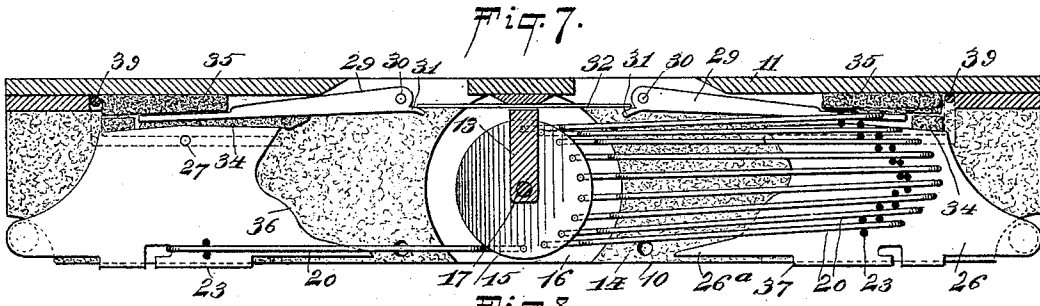

WITNESSES:
William Goebel.
C. Sedgwick

INVENTOR
C. P. Brown
 BY *Munn & Co.*
 ATTORNEYS.

UNITED STATES PATENT OFFICE.

CYRIL P. BROWN, OF SPRING LAKE, MICHIGAN.

MUSIC-LEAF TURNER.

SPECIFICATION forming part of Letters Patent No. 527,658, dated October 16, 1894.

Application filed November 27, 1893. Serial No. 492,127. (No model.)

To all whom it may concern:

Be it known that I, CYRIL P. BROWN, of Spring Lake, in the county of Ottawa and State of Michigan, have invented a new and

Improved Music-Leaf Turner, of which the following is a full, clear, and exact description.

My invention relates to improvements in that class of devices which are used to turn the leaves of music, whether in book or sheet form; and the object of my invention is to produce a simple apparatus of this kind, which has a plurality of fingers adapted to clasp any necessary number of leaves, which has means for easily turning the leaves one by one without touching the leaves with the hands, which has also means for turning back any desired number of leaves simultaneously, and which may be conveniently applied to any organ, piano, or music stand.

To this end my invention consists of certain features of construction and combinations of parts, which will be hereinafter described and claimed.

Reference is to be had to the accompanying drawings, forming a part of this specification, in which similar figures of reference indicate corresponding parts in all the views.

Figure 1 is a front elevation of the machine embodying my invention. Fig. 2 is a sectional plan on the line 2—2 of Fig. 1. Fig. 3 is a cross section on the line 3—3 of Fig. 1. Fig. 4 is a detail cross section through the central portion of the machine and shows the arrangement of the main wheel and the spring lock for engaging the cranks of the swinging arms. Fig. 5 is a detail plan view of one of the turning levers. Fig. 6 is a cross section on the line 6—6 of Fig. 5. Fig. 7 is a sectional plan of the machine with the turning arms in normal position. Fig. 8 is a similar view, but with one of the turning arms and the turning lever swung outward to throw the turning arm around; and Fig. 9 is a similar view with the turning lever thrown at right angles to the case or frame of the machine to force an arm into the correct position.

The machine is provided with a suitable case or frame, which comprises the bottom or bed 10, the back 11, the top 12, which is shorter than the bed and serves as a music

rest, and the transverse bridge or brace 13 on the under side of the rest or top 12, this serving to stiffen the top and also to form a support for the pivot screw of the main wheel. The top of the bed 10 is provided with a pad or covering 14, which deadens the sound when the moving parts of the device are actuated. In the center of the case is a horizontally turning wheel 15, which is held in a recess 16 in the bed, the recess being made in order to reduce the thickness of the machine and render it more compact, and the wheel turns on a pivot screw 17 which extends upward through the bottom or bed 10 and into the bridge or brace 13. The middle portion of the wheel is preferably thicker than the peripheral portion of the wheel, as shown at 18 in Figs. 3 and 4, as this enables the bent ends 19 of the swinging arms 20 to be more conveniently applied to the wheel. These bent ends 19, which are preferably approximately U-shaped, as shown clearly in Fig. 3 are formed on the inner ends of the swinging arms 20, which arms are adapted to swing outward from the front of the case or frame, and each arm is independently pivoted so that the arms may move independently of each other and each may turn on its own axis as well as swing with the wheel 15. Each arm 20 terminates at its outer end in an open loop 21, the loop being formed by doubling the arm, as shown in Fig. 1, and the loop has a terminal eye 22 in which is pivoted a pair of fingers 23, these fingers being formed of a single wire, or equivalent article, bent to a U-shape, and a leaf may thus be placed between a pair of fingers and held secure. Each pair of fingers is pivoted in one of the eyes 22 of a swinging arm 20, as specified, and when the fingers are not in use they may be folded down parallel with the arm 20.

Beneath the wheel 15 and projecting to a point beneath its outer periphery is a spring lock 24, in the form of a flat spring, fastened at its inner end and having an up-turned outer end 25, which up-turned end is rounded at opposite sides, as shown clearly in Fig. 1. The spring lock presses upward against the wheel and against the bent ends 19, and when

the arms 20 are in normal position, parallel with the case, the up-turned end prevents them from accidentally swinging outward, thus disengaging the music, and the rounded edges of the up-turned end of the spring lock permit the bent ends 19 to pass over and depress the said ends, so that the movement of the arms is not interfered with, but the tension of the spring serves to make the movement steady.

The arms 20 are turned by means of the turning levers 26, which are pivoted flatwise on the bed 10 on opposite sides of the main wheel 15, each lever being pivoted near its back side and center, as shown at 27, to a flange 28 on an arm 29, and the latter is pivoted, as shown at 30, in the back of the case. Each arm 29 has, near its pivot, a projecting lip or flange 31 which is adapted to engage a flat spring 32, this being arranged longitudinally in the back of the case, as shown clearly in Figs. 7 to 9, and the tension of this spring is such as to normally throw back the levers 26 and hold them parallel with the bed 10, as shown in Fig. 7. Each lever 26 terminates at its outer and inner edge in a point 26^a, which is adapted to successively engage the cranks 19 so as to force the bent ends and the arms 20 from one side or end of the machine to the other, and the inner end of each lever 26 is provided with a cam-like recess 36 which is adapted to engage a whole series of bent ends and assist in holding them and their arms in place. Each lever 26 is provided at its free end with a handle 33 by which it may be turned, and between the lever and its arm 29 is a packing 34, while a packing or cushion 35 is also arranged behind the lever, these packings or cushions being for the purpose of deadening sound when the lever is moved. Each lever has also on its outer edge a shoulder 37 which, when the lever is thrown outward at a right angle, is adapted to engage the bent end 19 of an arm 20, so as to force the arm well into the case, as illustrated in Fig. 9. By swinging one of the levers 26 outward repeatedly, the bent ends 19 are successively engaged by the point 26^a of the said lever, and the arms are thus thrown from one side to the other, while the shoulder 37 presses the arms to place, and the wheel 15 oscillates sufficiently to permit the ready turning and adjustment of the arms. The inner end of each lever is shaped to press the arms to place, and when the lever is turned back the manner in which it is pivoted on the flange 28 permits the point 26^a to run, without friction, over the several cranks, as the lever swings on its pivot 27 as well as on the main pivot 30.

On the under side of the bed 10 are clamping hooks 38, which are adapted to spring over a rest 38^a of a piano or organ, as shown in Fig. 3, and the hooks are preferably rubber covered to prevent them from scratching the rest. The ends of the case are also preferably provided with rubber bands 38^b, or

equivalent cushions, to prevent the case from coming into injurious contact with the front of a musical instrument. The hooks 38 are provided with shanks 39 which project upward through the case and act as pivots for the hooks 38, so that the latter may be turned at right angles to the case, as in Fig. 3, which enables them to clamp a music rest or to be turned parallel with the case, as in Fig. 1, when the case is held in a different manner, as hereinafter specified. The upper ends of the shanks 39 terminate in cranks 40, which may be utilized when the clamping hooks 38 are in the position shown in Fig. 1, to hold back the covers of a music book, the covers being placed behind the said cranks.

On the top of the machine is a lever 41, which I term a reversing lever, this being pivoted near the center of the machine, and at its outer end it is bent downward, as at 42, and terminates in a handle 43. This may be placed behind any desired number of fingers and arms, so that when the levers have been turned from right to left, one at a time, in playing, they may be simultaneously turned back by grasping and turning said lever. The case has projecting down through it, on opposite sides of the wheel 15, cords 44 or their equivalents, which are adapted to connect with the levers 26 and with a pedal below, so that when the device is applied to a music stand the levers and arms may be worked by the foot.

The part of the apparatus already described may be used as a complete music leaf turner, with ordinary instruments, but if desired and for certain purposes a binder, shown in Figs. 1 and 3, may be used in connection with the device. This binder is provided with a post 45, the lower end 46 of which is reduced and adapted to fit in a slot 46^a, see Fig. 4, in the top and back portion of the case, this arrangement giving the post sufficient stability and enabling it to be quickly removed when desired. The post 45 is provided with a binding or fastening device adapted to hold a book or sheet music in place, and this fastening device consists in part of a rod 47, which extends longitudinally of the post, the having eyes 48 formed thereon to receive screws or other fastenings. The upper end of the rod 47 is capable of springing outward and terminates in an eye 47^a. The lower end of the rod terminates in a coil 49 forming an eye to receive the crank 50 on the lower end of a swinging fastening rod 51, which extends parallel with the rod 47 and terminates at its upper end in an eye or ring 52, which is larger than the eye 47^a and is made at right angles to the same, so that the two eyes may interlock thus fastening the rods together.

To fasten a music book or sheet music to the binder, the eyes are separated, the rod 51 swung outward, the open book or sheet placed behind the rod 51, and the rod is then swung backward in the crease of the book or sheet

and locked in place and the covers of the book or the ends of the sheet may be held open by placing them behind the cranks 40. The post 45 is slotted transversely near the top, as shown at 53, and in this slot is hung an elastic band 54, or an equivalent spring, to the end of which is attached a hook 55, which is preferably rubber covered. The binder and this fastening just described are particularly adapted for attachment to a grand piano, and when thus applied, the hooks 38 are turned into a position shown in Fig. 1, and the hook 55 is placed in engagement with the openwork on the front of the piano, the tension of the band 54 serving to hold the device in place.

When the apparatus is to be used, the arms 20 are thrown to the right and as many pairs of fingers 23 turned up, as shown in Fig. 1, as there are leaves to be clasped, and the leaves are inserted between the fingers. It will be observed that when the fingers are turned up, as specified, each pair of fingers straddles the upper member of the loop 21, and the loop thus serves to brace the fingers.

When a leaf is to be turned, the lever 26, beneath the arms 20, is thrown outward at right angles to the case, as shown in Fig. 2, and this causes the point 26^a of the lever to engage the bent ends 19 of the outside arm 20 and thus fold the arm to the left side of the case, carrying a leaf with it, and the shoulder 37 of the lever 26 presses the crank and arm to place.

The swinging of the arms as above described, causes the wheel 15 to be turned so as to bring the next arm 20 into position to be engaged by the lever 26, when it has been released and thrown to its normal position by the spring 32. In this way the arms and leaves may be successively turned, after which they may be turned back by the lever 26 at the opposite end of the machine, or if they are to be turned back all at once, the lever 41 may be thrown outward so as to swing the several arms together, or this lever may be arranged behind any desired number of fingers so that the fingers and their arms may be turned back when desired.

It will be seen from the foregoing description that the machine may be conveniently applied to a music stand, piano or organ, and that by it the leaves may be turned quickly and conveniently and also held in different positions.

Having thus described my invention, I claim as new and desire to secure by Letters Patent—

1. A music leaf turner, comprising a case, a wheel pivoted thereon, a plurality of arms pivoted on the wheel and extending outwardly therefrom, swinging fingers arranged in pairs and pivoted at the outer ends of the said arms, and a lever for operating said arms and wheel, substantially as described.

2. A music leaf turner, comprising a suit-

able case or frame, a wheel pivoted thereon, a plurality of outwardly extending arms pivoted on the wheel and terminating at their outer ends in loops, a pair of parallel fingers pivoted to the lower member of each loop, and a lever for operating said arms and wheel, substantially as described.

3. A music leaf turner, comprising a suitable case or frame, a wheel pivoted horizontally thereon, a plurality of outwardly extending arms carried by the wheel, fingers at the outer ends of the arms to engage the leaves, and a spring lock pressing against the under side of the wheel and arms, substantially as described.

4. In a music leaf turner, the combination of the pivoted wheel, the arms carried by the wheel and having means for engaging the music leaves, and a spring beneath the wheel, pressing against the arms, substantially as described.

5. In a music leaf turner, the combination, of the wheel pivoted horizontally on the frame of the machine, the outwardly extending arms pivoted independently on the wheel, means at the outer ends of the arms for clasping music leaves, and a flat spring beneath the wheel, having an up-turned end extending into the paths of the arms, substantially as described.

6. In a music leaf turner, the combination of the swinging arms having terminal loops, and the parallel fingers pivoted in the lower members of the loops and adapted to swing upward and straddle the loops, substantially as described.

7. The combination, of the pivoted wheel, the outwardly extending arms pivoted thereon, and the swinging turning lever pivoted adjacent to the wheel and provided with a projecting point to engage the arms, substantially as described.

8. The combination, with the main wheel and the outwardly extending arms having bent ends pivoted to the wheel, of the turning lever pivoted adjacent to the wheel and provided with a projecting point to engage the bent ends of the arms, and a recessed end to close over said bent ends, substantially as described.

9. The combination, of the main wheel, the arms pivoted thereon, and the turning lever comprising an arm pivoted adjacent to the wheel, and a lever pivoted on the arm and provided with a projecting point to engage the said arms, substantially as described.

10. The combination, of the main wheel, the arms carried by the wheel, and the turning lever pivoted adjacent to the wheel, the lever having a projecting point to engage the arms, a recessed end to fit over the arms, and a shoulder on its outer side to press the arms, substantially as described.

11. The combination, of the main wheel, the arms carried by the wheel, and the turning lever to engage the arms, the lever compris-

ing a pivoted arm, a body portion pivoted on the said arm, and a packing between the rear edge of the lever and the arm, substantially as described.

5 12. The combination, with the case and its turning mechanism, of the clamping hooks pivoted on the under side of the case and

provided with shanks which extend upward through the case and terminate at their upper ends in cranks, substantially as described. 10
CYRIL P. BROWN.

Witnesses:

JOHN B. PRUIME,
BARNEY KLOUW.