

[54] **PRECISION SLITTING MACHINE FOR PLASTIC SHEETING**

[75] Inventors: **Frederick Hyatt, Providence; Theodore Robert Coburn, Coventry, both of R.I.**

[73] Assignee: **Marshall & Williams Company, Providence, R.I.**

[22] Filed: **Nov. 24, 1971**

[21] Appl. No.: **201,913**

[52] U.S. Cl. .... **83/122, 83/444, 83/449, 83/493, 83/503**

[51] Int. Cl. .... **B23d 19/06**

[58] Field of Search..... **83/122, 121, 444, 448-450, 83/500-503, 493**

[56] **References Cited**

**UNITED STATES PATENTS**

2,202,843	6/1940	Edward.....	83/122 X
303,893	8/1884	Stewart.....	83/500 X
3,286,574	11/1966	Durand.....	83/501

564,899	7/1896	Rahm.....	83/122
884,556	4/1908	Bauer.....	83/502
1,067,269	7/1913	Palmer.....	83/122
3,387,519	6/1968	Nebel.....	83/449 X
2,448,934	9/1948	VanDerhoeff et al.....	83/493 X

**FOREIGN PATENTS OR APPLICATIONS**

402,921	3/1943	Italy.....	83/501
---------	--------	------------	--------

*Primary Examiner*—J. M. Meister

*Attorney, Agent, or Firm*—William Frederick Werner

[57] **ABSTRACT**

A slitting machine for cutting thin plastic sheeting into narrow ribbons. A plurality of rotary cutter blades and a plurality of spacers are alternately fastened on a pair of spaced shafts with the blades on one shaft overlapping the blades on the other shaft. Opposed guide fingers suspended in pairs from a mounting means with each pair of guide fingers aligned with the spacers on both shafts are provided in order to define a guide path for the plastic sheeting.

**1 Claim, 10 Drawing Figures**

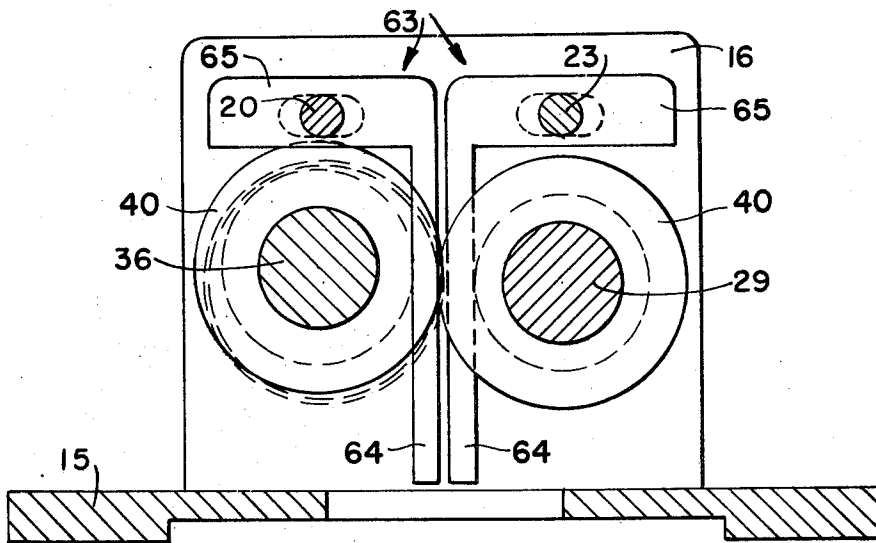

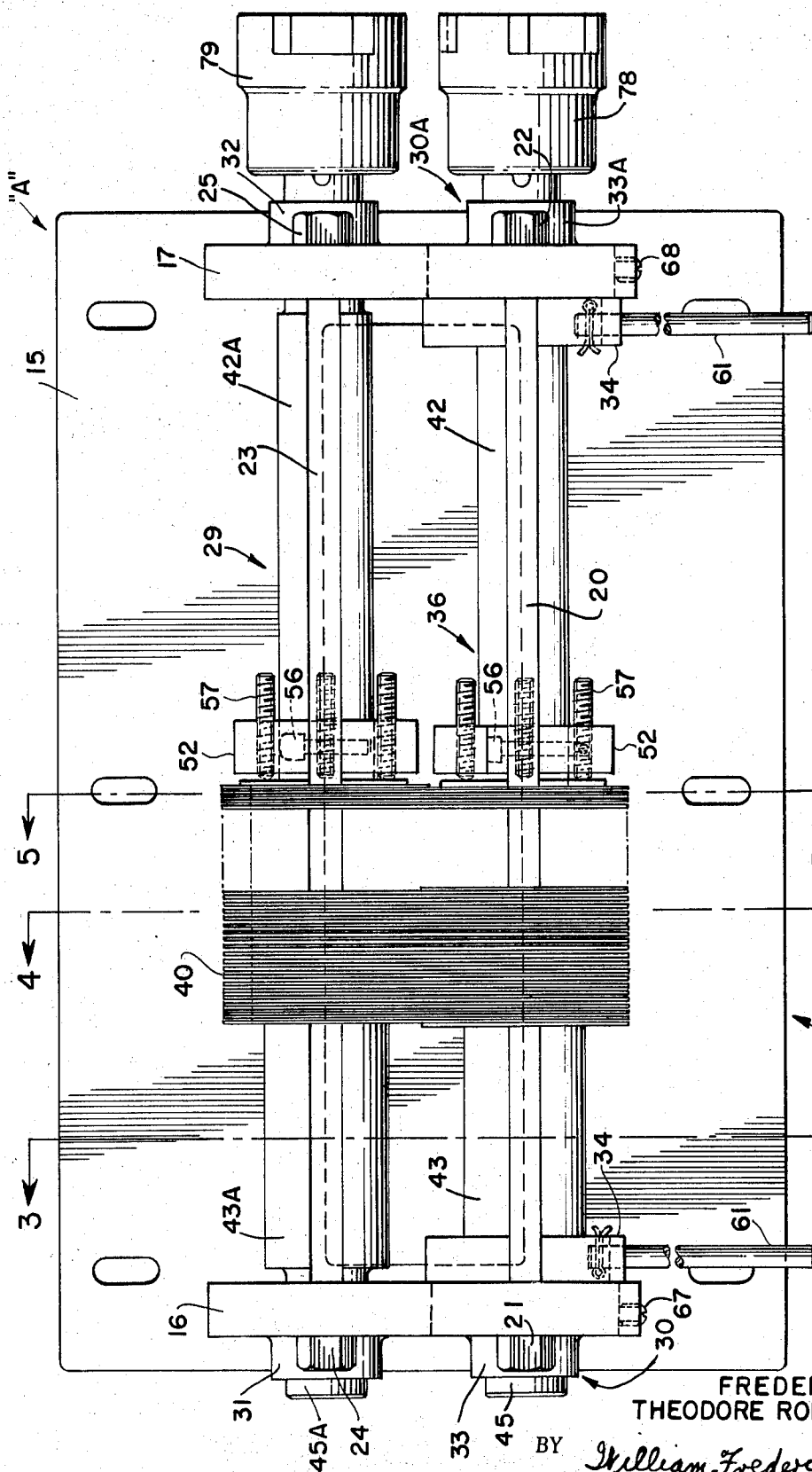

FIG. 1.

INVENTORS

FREDERICK HYATT &  
THEODORE ROBERT COBURN

BY *William Frederick Thonet*  
ATTORNEY

FIG. 2.

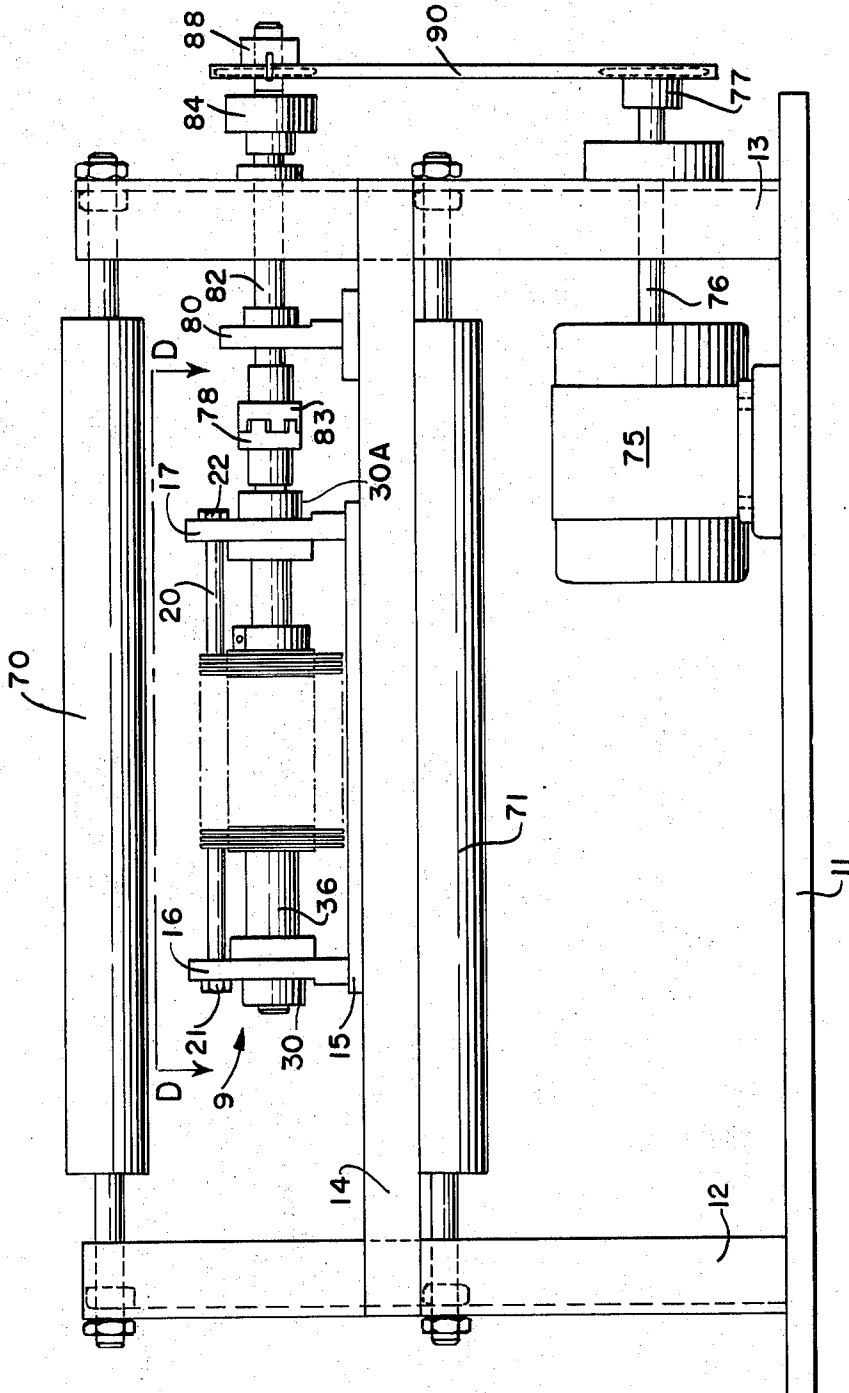

INVENTORS  
FREDERICK HYATT &  
THEODORE ROBERT COBURN

BY *William Frederick Kerner*  
ATTORNEY

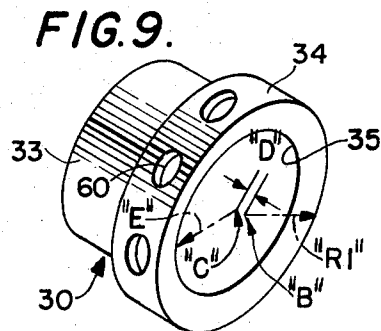
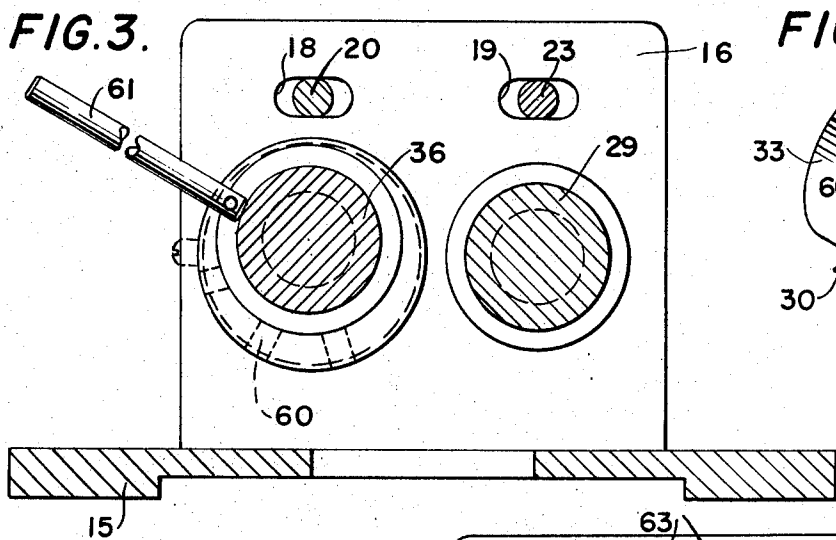

**FIG. 4.**

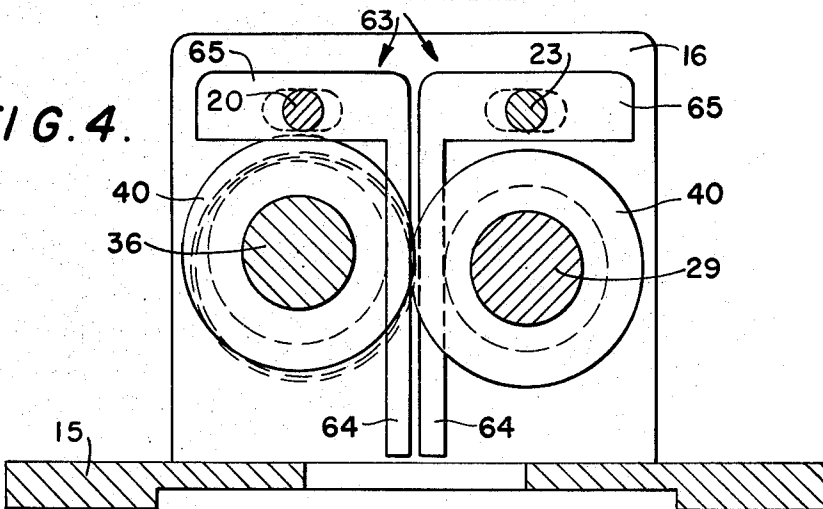

**FIG. 5.**

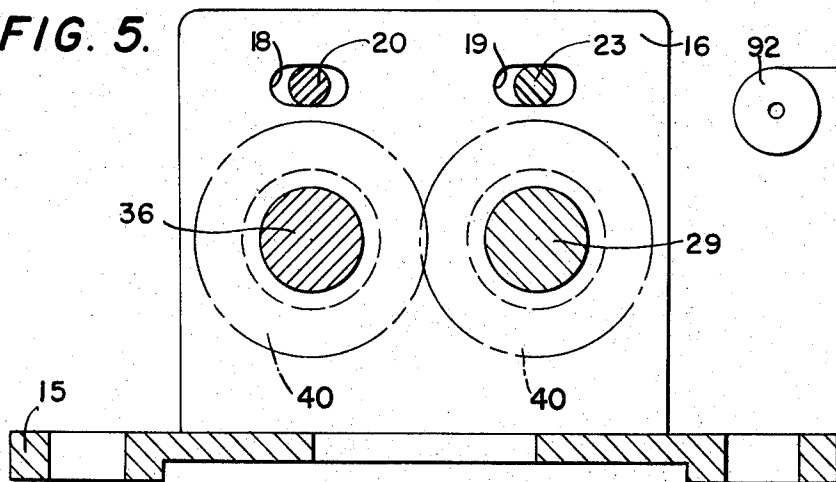

**FIG. 10.**

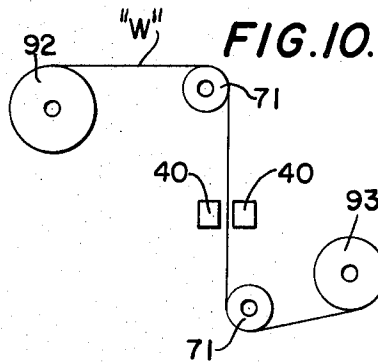

INVENTORS

FREDERICK HYATT &  
THEODORE ROBERT COBURN

BY *William Frederick Kerner*  
ATTORNEY

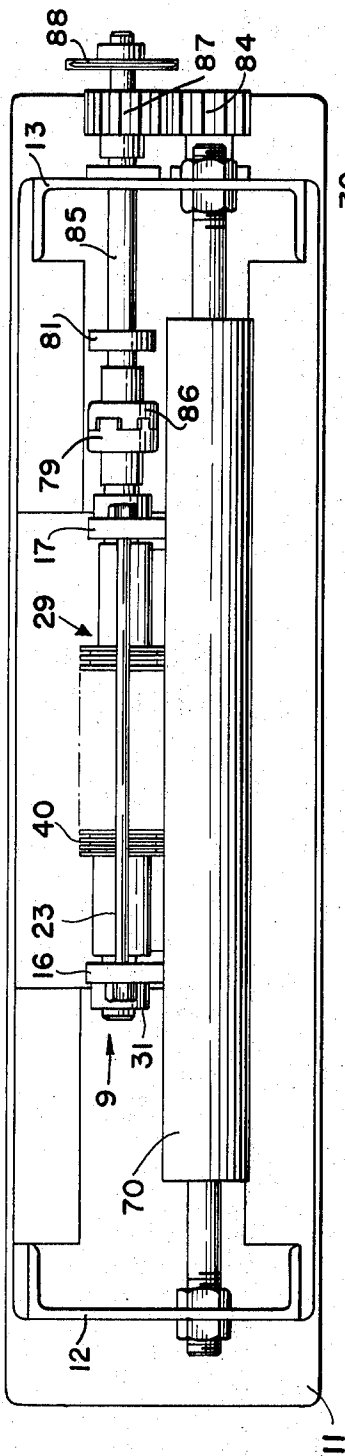

FIG. 6.

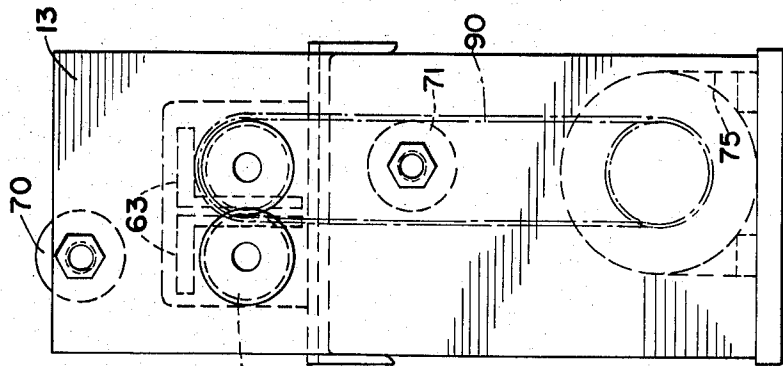

FIG. 7.

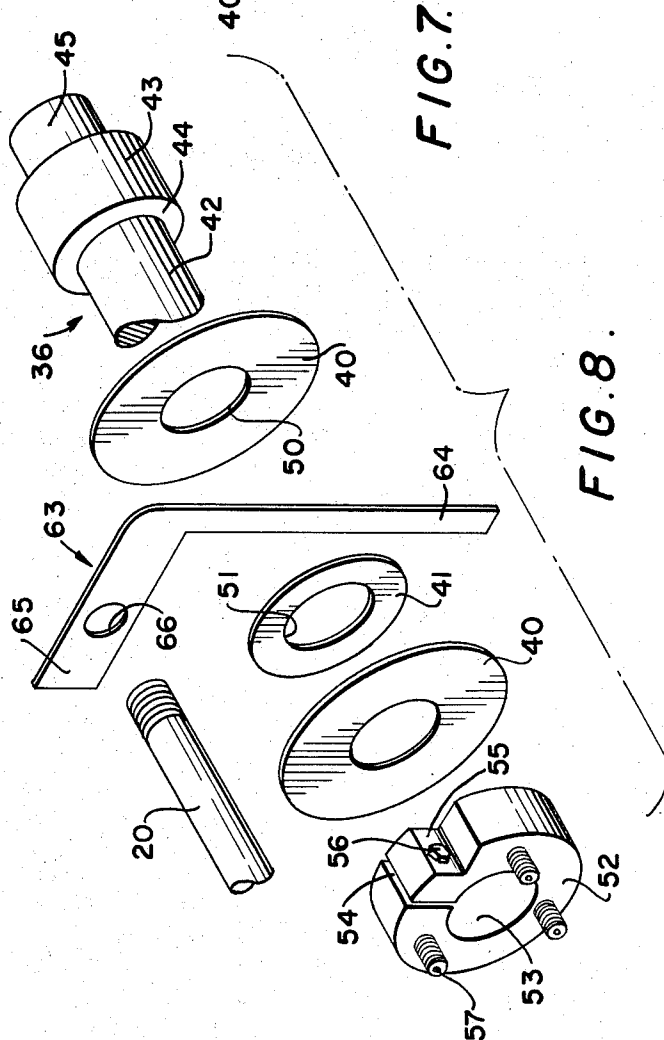

FIG. 8.

INVENTORS  
FREDERICK HYATT &  
THEODORE ROBERT COBURN

BY *William Frederick Thorne*  
ATTORNEY

## PRECISION SLITTING MACHINE FOR PLASTIC SHEETING

The carpet industry, in need for a substitute for jute, so as to provide, all weather carpets, decided that plastic film would satisfy all requirements, if strips of plastic film could be woven and or braided.

It is therefore a principal object of the present invention to provide a slitting machine which can cut a sheet of plastic material, in the nature of 10 mils or less in thickness, into ribbons or strips approximating 0.35 inch wide, with precision.

It is another object of the present slitting machine to provide mechanical means to prevent the cut strips of material from adhering to and following the cutter blade in rotational movement.

Other objects of the present invention will be pointed out in part and become apparent in part in the following specification and claims.

Referring to the drawings in which similar characters of reference indicate corresponding parts:

FIG. 1 is a plan view of the new and improved slitting machine, taken on line D—D of FIG. 2.

FIG. 2 is a front elevational view, looking at the delivery end of the slitting machine.

FIG. 3 is a vertical sectional view, partly in cross section, taken on line 3—3 of FIG. 1, looking in the direction of the arrows, and depicts an adjusting feature of the cutting blades.

FIG. 4 is a vertical sectional view, partly in cross-section, taken on line 4—4 of FIG. 1, looking in the direction of the arrows, and depicts the guide finger in relation to the cutting blades.

FIG. 5 is a vertical sectional view, partly in cross-section, taken on line 5—5 of FIG. 1, looking in the direction of the arrows, and depicts the overlapping structural feature of the two cutting blades.

FIG. 6 is a plan view of the new and improved slitting machine.

FIG. 7 is a right side elevational view of FIG. 6.

FIG. 8 is a fragmentary exploded perspective view of the cutting blades and guide fingers.

FIG. 9 is a detail perspective view of an eccentric cutter mounting shaft bushing.

FIG. 10 is a diagrammatic view of a conventional textile supply roll and take up roll with guide rolls directing the feed path of the web.

Referring to the drawings, the new and improved precision slitting machine comprises a base plate 11, provided with a vertical left side frame 12 and an oppositely located vertical right side frame 13. A base support 14 is fastened on opposite sides to the vertical left side frame 12 and to vertical right side frame 13.

A cutter frame 9, comprising a cutter frame base 15 provided with a left side 16 and a right side 17 is fastened to base support 14. Reference is directed to FIGS. 1, 3, 4 and 5.

Left side 16 is provided with two elongated slots 18 and 19. Similarly, right side 17 is provided with two elongated slots opposite and parallel (but not shown) to elongated slots 18 and 19.

A first guide rod 20, passes through elongated slot 18 and the slot opposite in right side 17 and is fastened to left side 16 and right side 17 in selected position by means of nuts 21, 22 respectively, of first guide rod 20.

Similarly, a second guide rod 23, passes through elongated slot 19 and the slot opposite in right side 17 and is fastened to left side 16 and right side 17 in se-

lected position by means of nuts 24, 25, respectively, threaded to opposite ends of second guide rod 23.

A first cutter blade mounting shaft 29 is rotatively mounted on bearings 31, 32 which form an integral part, respectively, of left side 16 and right side 17.

Reference is now made to FIG. 9 wherein is illustrated an eccentric bushing 30 comprising a body 33 provided with an enlarged end 34. A bore 35 is eccentrically provided in body 33. Center B is the concentric center to body 33 and enlarged end 34 as indicated by radius RI. The center C is offset from center B an amount indicated at D and the radius E scribes the offset nature of bore 35 which serves the function of a bearing for second cutter blade mounting shaft 36. Body 33 is fixed in left side 16, which has an opening to receive body 33, by means of a set screw 67. An identical and companion bushing 30A is fixed in right side 17, which has an opening to receive body 33A, by means of a set screw 68.

Eccentric bushings 30, 30A are provided with pilot orifices 60 into which a handle 61 is inserted to facilitate the partial rotation of bushings 30, 30A.

As illustrated in FIG. 8, second cutter blade mounting shaft 36 comprises a cutter blade 40 and spacer 41 supporting section 42, a collar section 43 which provides a wall 44, and bearing surfaces 45 on opposite ends which are supported in eccentric bores 35, 35A.

In like manner, first cutter blade mounting shaft 29 is provided with a cutter blade 40 and spacer 41 supporting section 42A, a collar section 43A which provides a wall 44A, and bearing surfaces 45A on opposite ends which are supported, respectively, in left side 16 and right side 17, as previously stated.

In assembling a gang of cutter blades 40 on shaft 29 or 36, a cutter blade 40 provided with a shaft opening 50 is passed along cutter blade and spacer supporting section 42 and against wall 44. A spacer 41 provided with a shaft opening 51 is passed along cutter blade and spacer supporting section 42 and against cutter blade 40. Alternately, cutter blades 40 and spacers 41 are passed along section 42 until the desired number of cutter blades 40 are provided upon shaft 29 and/or 36.

A split collar 52 having a shaft gripping area 53 is provided with a slot 54 and a cut out providing a clamping wall 55. A screw having a head 56 passes through a clearance orifice in wall 55 and is rotatively mounted in screw threads in collar 52. Three jack screws 57 are rotatively mounted in split collar 52. Shaft gripping area 53 is passed along blade and spacer supporting section 42 until split collar 52 abuts a spacer 41. Collar 52 is then fastened to shaft 29 and or 36 by means of set screw 56. In this manner the gang of cutter blades 40 and spacers 41 are fastened to shaft 29 and/or 36. However, an optional feature, in the form of the jack screws 57 permits the jack screws 57 to force the gang of cutter blades 40 and spacers 41 against wall 44 and in addition by adjusting jack screws 57 through rotation the cutter blades 40 can be aligned vertically.

The shaft 29 is then passed into shaft bearing 32 in right side 17 a sufficient amount to permit the opposite end of the shaft 45A to be aligned with and passed into shaft bearing 31 in left side 16.

In like manner, shaft 36 is passed through eccentric bore 35A a sufficient amount to permit end 46 to be aligned with and passed into eccentric bore 35.

Reference is now made to FIGS. 1, 3, 4, 5 and 7 which shows that the cutter blades 40 on shaft 36 align

with the cutter blades 40 on shaft 29. In addition, it will be seen that by rotating eccentric bushings 30, 30A simultaneously, the cutter blades 40 on shaft 36 can be moved toward and away from the cutter blades 40 on shaft 29.

The cutter blades 40 on shaft 36 are moved away from cutter blades 40 on shaft 29 when a sheet of plastic is initially threaded into the gang of cutter blades. The cutter blades 40 on shaft 36 are moved toward the cutter blades 40 on shaft 29 the desired amount to insure optimum cutting or shearing efficiency. As shown in FIG. 5, the blades 40 on shafts 36, 29 may overlap to provide a shearing edge.

The spacers 41 determine the width of the ribbons or strips into which the plastic sheet is cut.

FIGS. 1, 4, 7 and 8 illustrate the guide fingers 63 which comprise the shape of a hockey stick, namely, a handle 64 integrally connected to an arm 65 located at right angles to the handle 64. Arm 65 is provided with an orifice 66. Guide fingers 63 are strung along first guide rod 20 and second guide rod 23 in numbers equal to the number of spacers 41 on shafts 29, 36. The legs 64 are aligned opposite each other on, respective, shafts 29, 36 so as to define a guide path for a sheet of material between the opposed legs and in addition are aligned with spacers 41 on the, respective, shafts 29, 36.

First guide rod 20 and second guide rod 23, through elongated solts 18 and 19, respectively, adjustably align guide fingers 63 in relation to the cutter blades 40 (see FIG. 4).

A top guide roll 70 is mounted, for rotation, on opposite ends in, respectively, vertical left side frame 12 and vertical right side frame 13. Similarly, a bottom guide roll 71 is mounted, for rotation, on opposite ends in, respectively, vertical left side frame 12 and vertical right side frame 13. As seen in FIG. 7, these two rolls 70, 71 are vertically aligned above and below guide fingers 63 and cutter blades 40 to position the sheet of material in a vertical position during the cutting or shearing operation.

A motor 75 provided with a power shaft 76 is fastened to base plate 11, (see FIGS. 1, 2 and 6), a sprocket 77 is fastened to power shaft 76. A male shaft couple 78 is fastened to one end 45 of shaft 36. Similarly, a male shaft couple 79 is fastened to one end 45A of shaft 29. Bearing stands 80 and 81, are fastened to base support 14. A first short shaft 82 provided with a female shaft couple 83 on one end and spur gear 84 on the other end, is rotatively mounted in bearing stand 80 and in vertical right side frame 13 with shaft couple 83 in engagement with shaft couple 78. Similarly, a second short shaft 85 provided with a female shaft couple 86 on one end and with a spur gear 87 and a sprocket 88 on the other end, is rotatively mounted in bearing stand 81 and in vertical right side frame 13 with shaft couple 86 in engagement with shaft couple 79 and with gear 87 in mesh with gear 84. A sprocket chain 90 rotatively connects sprocket 77 with sprocket 88.

In operation a sheet of plastic film of any given length is passed over top guide roll 70 and the leading end of the sheet fed from above between cutter blades 40 and guide fingers 63 on shaft 29 and rod 23, cutter blades 40 and guide fingers 63 on shaft 36 and rod 20. As previously described, the cutter blades 40 and guide fingers 63 will be adjusted to provide the proper cutting relationship between each set of cutting blades and the

proper guiding of the sheet through the guide finger. The sheet is then fed over bottom guide roll 71. In one form contemplated, motor 75 through shaft 76, sprockets 77, 78 and gears 84, 87 will rotate first cutter blade mounting shaft 29 and second cutter blade mounting shaft 36, to thereby, rotate cutter blades 40.

Another form contemplated is shown in FIG. 10, which diagrammatically illustrates a supply roll 92 upon which is wound a supply of plastic film. As is well known in the textile art, roll 92 may be driven at a selected speed to allow the plastic film web to be withdrawn at a selected number of yarns per minute.

Top guide roll 70 and bottom guide roll 71 provide a guide path for the web through the cutter blades 40.

A take up roll 93 is rotated in sequence with supply roll 92 so that the web W may be drawn through the cutter blades 40 whether the cutter blades 40 are rotating or stationary. In this form the strength of the film must be strong enough to overcome the frictional drag of the stationary cutters or blades.

Guide fingers 63 direct the individual ribbons or strands, through the blades 40 as the strands are cut out of the sheet, and thereby prevent the strands from wrapping around the cutter blades 40.

Having shown and described a preferred embodiment of the present invention by way of example, it should be realized that structural changes could be made and other examples given without departing from either the spirit or scope of this invention.

What I claim is:

1. A precision slitting machine for plastic sheeting comprising a cutter frame, a first cutter blade shaft, a plurality of cutter blades, a plurality of spacers, means alternately fastening said plurality of cutter blades and said plurality of spacers upon said first cutter blade shaft, a second means supporting said first cutter blade shaft in said cutter frame, a second cutter blade shaft, a second plurality of cutter blades, a second plurality of spacers, a third means alternately fastening said second plurality of cutter blades and said second plurality of spacers upon said second cutter blade shaft, a fourth means supporting said second cutter blade shaft in said cutter frame with said second plurality of cutter blades aligned with said first mentioned plurality of cutter blades, that improvement which comprises a plurality of guide fingers, support means suspending said plurality of guide fingers in pairs, with each pair of guide fingers aligned with spacers on both said first cutter blade shaft and said second cutter blade shaft, and means for presenting a sheet of material to said plurality of cutter blades, a first and a second elongated slot (are provided) in said left side, a third elongated slot aligned with said first elongated slot and a fourth elongated slot aligned with said second elongated slot are provided in said right side, a first guide rod adjustably fastened in said first and third elongated slot, a second guide rod adjustably fastened in said second and fourth elongated slot, a first plurality of guide fingers supported upon said first guide rod, a second plurality of guide fingers supported upon said second guide rod with said second plurality of guide fingers aligned with said first plurality of guide fingers to provide pairs of guide fingers alternately located between the alternately located plurality of cutter blades on said first cutter blade shaft and said second cutter blade shaft.

\* \* \* \* \*