



(11) **EP 3 486 599 A1**

(12) **EUROPEAN PATENT APPLICATION**  
published in accordance with Art. 153(4) EPC

(43) Date of publication:  
**22.05.2019 Bulletin 2019/21**

(51) Int Cl.:  
**F41H 13/00** <sup>(2006.01)</sup> **F42B 12/34** <sup>(2006.01)</sup>  
**F42B 30/06** <sup>(2006.01)</sup> **F41A 21/32** <sup>(2006.01)</sup>  
**F41C 27/06** <sup>(2006.01)</sup>

(21) Application number: **17827049.2**

(22) Date of filing: **28.06.2017**

(86) International application number:  
**PCT/ES2017/070467**

(87) International publication number:  
**WO 2018/011444 (18.01.2018 Gazette 2018/03)**

(84) Designated Contracting States:  
**AL AT BE BG CH CY CZ DE DK EE ES FI FR GB GR HR HU IE IS IT LI LT LU LV MC MK MT NL NO PL PT RO RS SE SI SK SM TR**  
Designated Extension States:  
**BA ME**  
Designated Validation States:  
**MA MD**

(71) Applicant: **Pérez Calle, Eduardo**  
**46950 Xirivella (ES)**

(72) Inventor: **Pérez Calle, Eduardo**  
**46950 Xirivella (ES)**

(74) Representative: **Sahuquillo Huerta, Jesús**  
**C/ Reverendo José Noguera 33-14**  
**46017 Valencia (ES)**

(30) Priority: **12.07.2016 ES 201630902 U**

(54) **DEVICE FOR LAUNCHING INCAPACITATING PROJECTILES**

(57) The invention relates to a device for launching incapacitating projectiles, comprising: a body (1) which is connected to a weapon (2) using a hoop or ring (3). According to the invention, the body (1) includes a series of fins (4) that expand when the body (1) has been fired, so as to slow it down, and the interior of the body (1)

comprises a series of strips or fibres of a ballistic material (5) housed in an inner cavity (6), which slow down the propulsion of the primary projectile (7) fired from the weapon (2), thereby activating the body (1) and a secondary projectile (8) located at the end opposite the mouth (3).

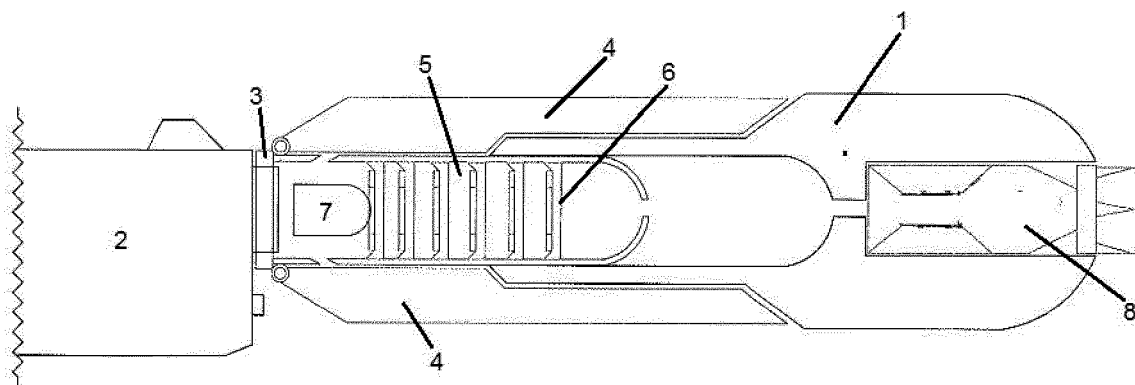

**FIG. 1**

**EP 3 486 599 A1**

## Description

**[0001]** The purpose of this utility model is an immobilizing projectile firing device that is magnetically attached to virtually all of the short-range weapons within the area where the projectile is fired, trapping the projectile in a muzzle and obtaining several functions from the moment of firing, for example: reducing the lethality of the shot by retaining the projectile, increasing its mass, its volume and reducing its speed, since this device utilizes the kinetic energy of the projectile to compress an internal chamber, which, when reduced in volume, violently forces the release of a secondary projectile due to the effect of air compression contained in that chamber, such as: electronic incapacitation modules, disabling chemical capsules, tranquilizer darts or simply considerable mass bodies designed to only hit the target in a non-lethal way, always utilizing the inertia and kinetic energy of a potentially lethal shot, offering a wide range of possibilities to the user without modifying the weapon or its ammunition in any way.

### Background for the invention

**[0002]** At present within the European Union electric shock pistols (or shotguns) are subject to controversy due to various accidents that have caused serious injury or even death. These are characterized as such because the projectile is always attached to the weapon, regardless of whether it is in use or not, and gives an electric shock to the user, leaving them immobile.

**[0003]** To all eviate this problem, it is well known that American patent US2011203151 describes a method and apparatus for the firing of electrified fire arm projectiles (a shotgun) using a cylinder head closure specially designed to avoid firing lethal ammunition. This document is especially focused on its use in shotguns and has a specific cartridge.

**[0004]** The main difference between the invention presented here and the American document is that the invention proposed here is a medium attached to any active short-range weapon, whereas in the American document it is confined to a medium that is introduced within the shotgun or electrified weapon that propels it at the target.

**[0005]** The main difference between the invention presented here and the American document lies in the fact that the invention proposed herein is a means capable of attaching itself to any active short-range weapon on the part of the user in a simple and quick way, while in the American document it is limited to a medium that is inserted into a shotgun.

**[0006]** The invention recommended here is also differentiated by the fact that, being an external element or means, it is the agent that makes the decision regarding its use when necessary; in addition, it is not necessary to modify active weapons of state bodies and security, so agents will not have to carry two differentiated weapons and will not need a high economic disbursement,

since it will only be necessary to buy the device in order to employ it.

**[0007]** Similarly, the solution proposed in the American patent also differs in that its immobilizing means will be exclusively an electric shock, whereas in the case of the invention proposed here it may be either an electric shock, a paralyzing gas or any other similar means.

**[0008]** In the case of the invention described, this will not contain any cable that joins the immobilizer and the weapon, which directly affects the target being fired at. Currently, one of the drawbacks and main points of controversy regarding the use of electric pistols is that the user can use the trigger to vary the intensity and/or duration of the fire, which has caused cases of excessive use of electric power and has caused significant injuries and, in extreme cases, the death of person receiving the discharge.

**[0009]** This is eliminated with the invention described here, since as the projectile is independent of the will of the agent firing it, the duration of the discharge of the projectile will be predesigned and the user will not be able to vary its duration and must fire it again to increase the discharge time, minimizing the risk of a discharge that is dangerous to the physical integrity of the person receiving it

### Description of the invention

**[0010]** The technical problem this invention solves is obtaining a device that can be attached to a firearm (mainly a short-range weapon) to fire an immobilizing projectile at a target and to paralyze the target reducing the risk of permanent damage upon impact To this end, the immobilizing projectile launcher, which is the object of this utility model, is characterized by the fact that it comprises a neodymium crown or ring, which is the same as a non-permanent bond between the weapon and the device.

**[0011]** It also includes a body, which incorporates a series of fins that open up to stabilize and slow it down once it is in free flight so that the secondary projectile and the body itself move at different but parallel speeds and trajectories.

**[0012]** Inside the body there is a system to absorb the impact of the primary projectile made of ballistic material, while compressing the air held in a posterior chamber enabled for that purpose. This compression is that which drives the secondary projectile. After that, the energy not absorbed by the reaction described above would put the rest of the device in motion. It detaches itself from the magnetic connection to the weapon and is projected along a trajectory slowed down by the fins towards the target.

**[0013]** Thanks to its design, the device can be attached to any type of short-range weapon, where, thanks to its magnetic union, a sufficiently durable union is generated so there is no risk of possible incidents during its use. This include detachments due to violent movements

when the agent is under stress.

**[0014]** Similarly, by using the device presented here, the user will be able to convert a potentially lethal shot into a shot of reduced or negligible lethality because, unlike conventional electric pistols, the shot only causes a controlled shock and does not allow the user the possibility of increasing or decreasing the intensity of the discharge.

**[0015]** Because the weapon to which the device is attached nor the ammunition it uses is not modified, its maintenance and the manufacturer's warranty (that of both the gun and the ammunition used) are not altered.

**[0016]** If the use of the device is not sufficiently effective or deterrent, the user will be able to dismantle the device and use their short-range weapon in a conventional manner. This means the user is properly armed in critical situations.

**[0017]** The use of the device presented here will allow the user's weapon to not go unused after having used it against a target, since the weapon is completely free to be used against another target under normal use. This can be vital in dangerous operations, where the user decides to use the immobilizer immediately upon encountering a target, and if that weren't not enough, or there are other targets, they can use their active weapon normally (or by attaching it to another device such as the one presented here).

**[0018]** Throughout the description and the claims, the word 'comprises' and its variants do not intend to exclude other technical characteristics, additives, components or steps. For experts in the field, other objects, advantages and characteristics of the invention will be derived in part from the description and in part from the use of the invention. The following examples and figures are provided by way of illustration and are not intended to restrict this invention. This invention also covers all possible combinations of particular and preferred embodiments indicated herein.

#### Brief description of the figures

**[0019]** A brief description is given below of a series of illustrations that help to better understand the invention and are expressly related to an implementation of said invention that is presented as a non-limiting example.

Fig.1 shows a schematic view of the immobilizing projectile firing device attached to a weapon when triggered.

Fig.2 shows a schematic view of the immobilizing projectile firing device attached to a weapon once it has been fired from the weapon.

Fig.3 shows a schematic view of the device once the immobilizing medium leaves the device presented here.

#### Preferred use of the invention

**[0020]** A preferred use of the invention is shown in the attached figures. More specifically, the immobilizing projectile firing device, which is the object of this document, is characterized by the definition of a body (1) that attaches to a weapon (2) through its crown (3) or ring made of a high-performance magnetic material, such as neodymium or alnico.

**[0021]** The body incorporates a series of fins (4) that will open up to slow down the body (1) once it has been fired from the weapon (2).

**[0022]** Internally, the body (1) presents a series of strips or fibres of a ballistic material (5) such as, for example, Dyneema or similar, housed in an internal cavity (6) that slows down the propulsion of a primary projectile (7) fired in the weapon (2) using a dock-like effect. The action of the primary projectile (7) in the cavity (6) will activate the device, and when the fibres (5) have completely contracted, the propulsion of the secondary projectile (8) will be activated and released to be able to act against the target.

**[0023]** The secondary projectile (8) is located at the opposite end of the crown or ring (3) which joins the body (1) to the weapon (2).

**[0024]** This secondary projectile (8) may be an electric shock, a paralyzing gas, a dart, or a similar medium.

#### Claims

1. Immobilizing projectile firing device comprised of a body (1) which is attached to a weapon (2) by its crown or ring (3) and that is **characterized in that** the body (1) incorporates a series of fins (4) that expand when the body (1) has been fired in order to slow it down; and **in that** the body (1) internally presents a series of strips or fibres of a ballistic material (5) lodged in an internal cavity (6), which stop the propulsion of the primary projectile (7) fired by the weapon (2), which activates the body (1) and a secondary projectile (8) located at the opposite end of the mouth (3).
2. A device in accordance with claim 1, where the secondary projectile (8) is an electric shock, a paralyzing gas, a dart or a similar medium.
3. A device in accordance with claim 1 where the mouth (3) is materialized using a high-performance magnetic material, such as neodymium, alnico or a material with equivalent mechanical characteristics.
4. Device according to claim 1 where the ballistic material is Dyneema or a material with equivalent mechanical characteristics.

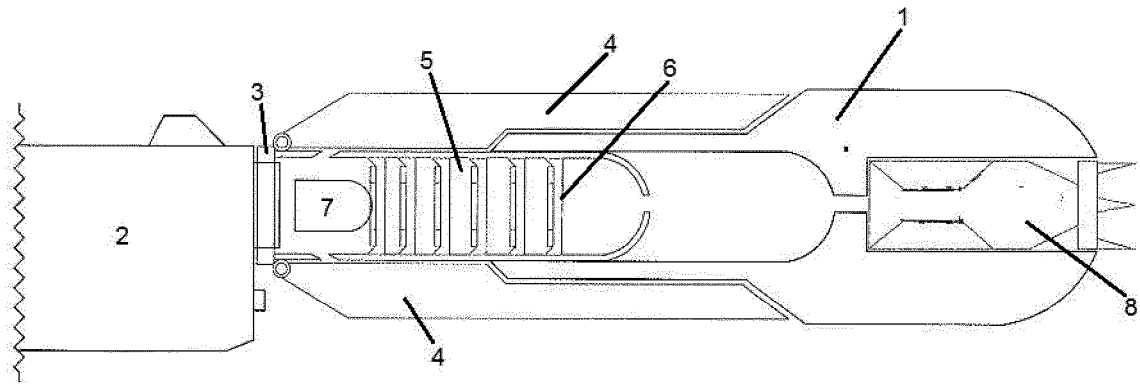

**FIG. 1**

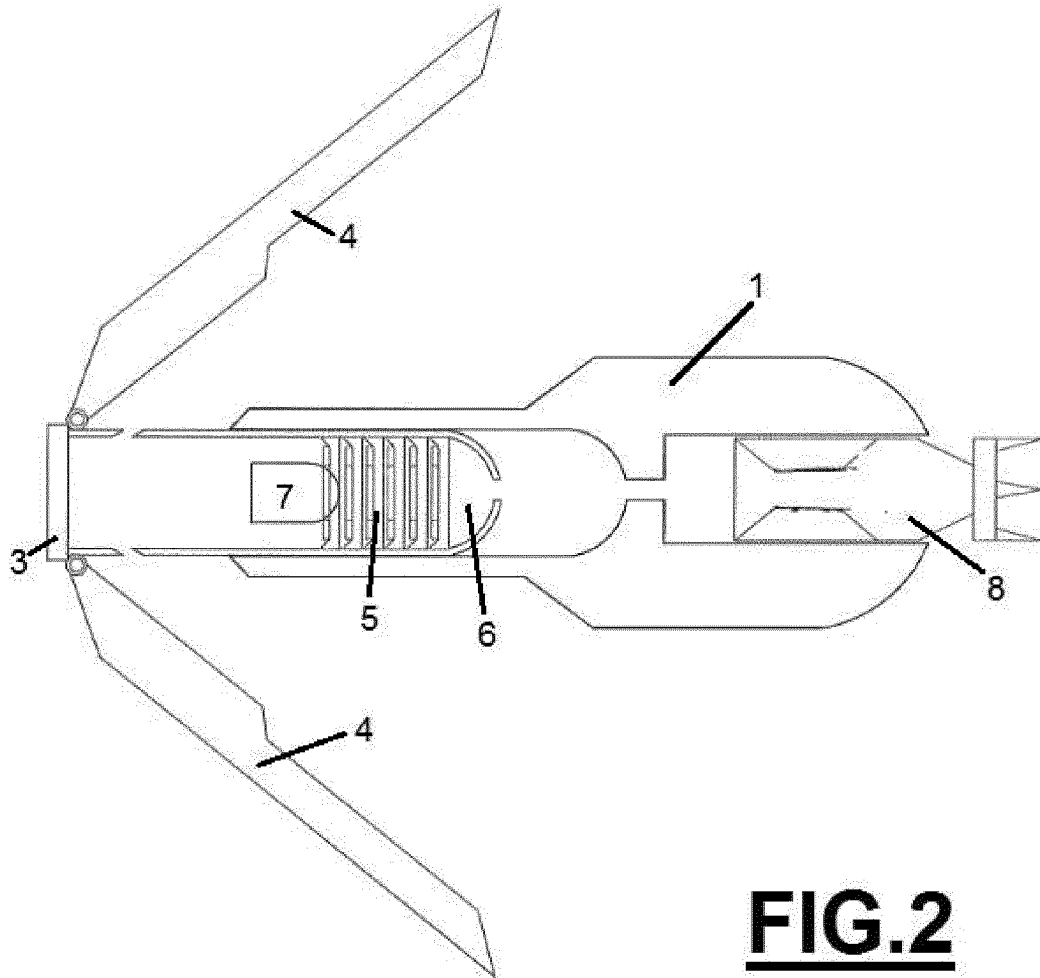

**FIG. 2**

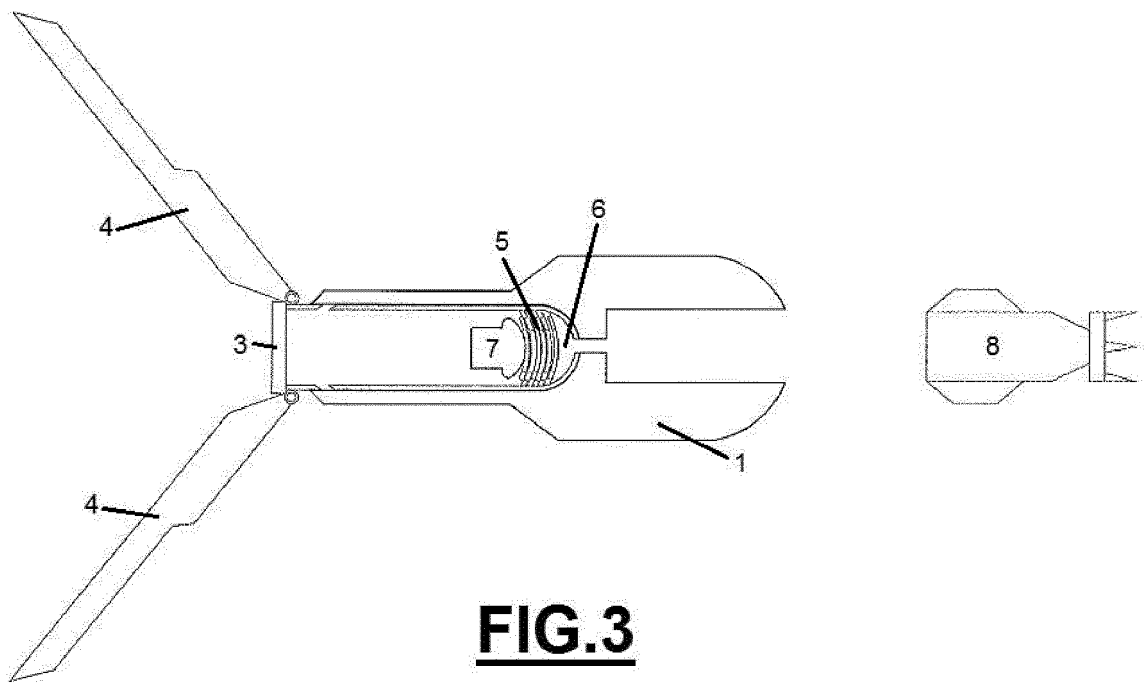

**FIG.3**

## INTERNATIONAL SEARCH REPORT

International application No.

PCT/ES2017/070467

5

## A. CLASSIFICATION OF SUBJECT MATTER

**See extra sheet**

According to International Patent Classification (IPC) or to both national classification and IPC

10

## B. FIELDS SEARCHED

Minimum documentation searched (classification system followed by classification symbols)

F41H, F42B, F41A, F41C

Documentation searched other than minimum documentation to the extent that such documents are included in the fields searched

15

Electronic data base consulted during the international search (name of data base and, where practicable, search terms used)

EPODOC, INVENES

## C. DOCUMENTS CONSIDERED TO BE RELEVANT

20

Category*	Citation of document, with indication, where appropriate, of the relevant passages	Relevant to claim No.
Y	US 2014109454 A1 (RAYNER WILLIAM V S) 22/04/2014, paragraphs [45-72]; figures 6-13.	1-4
Y	US 8910411 B1 (CALVERT S MILL) 16/12/2014, column 2, lines 23 - 33; column 3, lines 27 - 29; figure 2.	1-4
A	US 5221809 A (CUADROS JAIME H) 22/06/1993, column 2, line 65 - column 3, line 13; figures 1, 2.	1
A	US 3664263 A (DRISCOLL JOHN J) 23/05/1972, column 1, line 57 - column 2, line 34; figures 1 - 3.	1,3
A	US 6523478 B1 (GONZALEZ NOEL ET AL.) 25/02/2003, description; figures.	1,2

35

 Further documents are listed in the continuation of Box C.
  See patent family annex.

40

* Special categories of cited documents:	"T" later document published after the international filing date or priority date and not in conflict with the application but cited to understand the principle or theory underlying the invention
"A" document defining the general state of the art which is not considered to be of particular relevance.	
"E" earlier document but published on or after the international filing date	
"L" document which may throw doubts on priority claim(s) or which is cited to establish the publication date of another citation or other special reason (as specified)	"X" document of particular relevance; the claimed invention cannot be considered novel or cannot be considered to involve an inventive step when the document is taken alone
"O" document referring to an oral disclosure use, exhibition, or other means.	"Y" document of particular relevance; the claimed invention cannot be considered to involve an inventive step when the document is combined with one or more other documents, such combination being obvious to a person skilled in the art
"P" document published prior to the international filing date but later than the priority date claimed	"&" document member of the same patent family

45

50

Date of the actual completion of the international search  
11/10/2017Date of mailing of the international search report  
(08/11/2017)

Name and mailing address of the ISA/

Authorized officer  
C. Piñero AguirreOFICINA ESPAÑOLA DE PATENTES Y MARCAS  
Paseo de la Castellana, 75 - 28071 Madrid (España)  
Facsimile No.: 91 349 53 04

Telephone No. 91 3493405

55

Form PCT/ISA/210 (second sheet) (January 2015)

INTERNATIONAL SEARCH REPORT

International application No.  
PCT/ES2017/070467

5  
10  
15  
20  
25  
30  
35  
40  
45  
50  
55

C (continuation). DOCUMENTS CONSIDERED TO BE RELEVANT		
Category *	Citation of documents, with indication, where appropriate, of the relevant passages	Relevant to claim No.
A	CN 101216274 A (YINSHI JIN YINSHI JIN) 09/07/2008, description (automatic traduction); figures 1,2.	1,2

Form PCT/ISA/210 (continuation of second sheet) (January 2015)

INTERNATIONAL SEARCH REPORT

International application No.

PCT/ES2017/070467

Information on patent family members

5  
10  
15  
20  
25  
30  
35  
40  
45  
50  
55

Patent document cited in the search report	Publication date	Patent family member(s)	Publication date
US2014109454 A1	22.04.2014	EP3217138 A1 EP3222962 A1 WO2014120297 A1 EP2909565 A1 EP2909565 A4 US8701325 B1	13.09.2017 27.09.2017 07.08.2014 26.08.2015 12.10.2016 22.04.2014
----- US8910411 B1	----- 16.12.2014	----- WO2015183359 A2 WO2015183359 A3	----- 03.12.2015 28.01.2016
----- US5221809 A	----- 22.06.1993	----- NONE	-----
----- US3664263 A	----- 23.05.1972	----- BE754543 A1	----- 08.02.1971
----- US6523478 B1	----- 25.02.2003	----- US6688032 B1	----- 10.02.2004
----- CN101216274 A	----- 09.07.2008	----- CN101216274B B	----- 18.08.2010
-----	-----	-----	-----

INTERNATIONAL SEARCH REPORT

International application No.

PCT/ES2017/070467

5

**CLASSIFICATION OF SUBJECT MATTER**

*F41H13/00* (2006.01)

*F42B12/34* (2006.01)

*F42B30/06* (2006.01)

*F41A21/32* (2006.01)

*F41C27/06* (2006.01)

10

15

20

25

30

35

40

45

50

55

**REFERENCES CITED IN THE DESCRIPTION**

*This list of references cited by the applicant is for the reader's convenience only. It does not form part of the European patent document. Even though great care has been taken in compiling the references, errors or omissions cannot be excluded and the EPO disclaims all liability in this regard.*

**Patent documents cited in the description**

- US 2011203151 A [0003]