

(12) INTERNATIONAL APPLICATION PUBLISHED UNDER THE PATENT COOPERATION TREATY (PCT)

(19) World Intellectual Property Organization  
International Bureau



(43) International Publication Date  
30 October 2003 (30.10.2003)

PCT

(10) International Publication Number  
**WO 03/088815 A2**

- (51) International Patent Classification<sup>7</sup>: **A61B**
- (21) International Application Number: PCT/US03/12094
- (22) International Filing Date: 17 April 2003 (17.04.2003)
- (25) Filing Language: English
- (26) Publication Language: English
- (30) Priority Data:  
60/373,710 17 April 2002 (17.04.2002) US
- (71) Applicant: **TYCO HEALTHCARE GROUP, LP**  
[US/US]; 150 Glover Avenue, Norwalk, CT 06856 (US).
- (81) Designated States (*national*): AE, AG, AL, AM, AT, AU, AZ, BA, BB, BG, BR, BY, BZ, CA, CH, CN, CO, CR, CU, CZ, DE, DK, DM, DZ, EC, EE, ES, FI, GB, GD, GE, GH, GM, HR, HU, ID, IL, IN, IS, JP, KE, KG, KP, KR, KZ, LC, LK, LR, LS, LT, LU, LV, MA, MD, MG, MK, MN, MW, MX, MZ, NO, NZ, OM, PH, PL, PT, RO, RU, SC, SD, SE, SG, SK, SL, TJ, TM, TN, TR, TT, TZ, UA, UG, UZ, VC, VN, YU, ZA, ZM, ZW.
- (84) Designated States (*regional*): ARIPO patent (GH, GM, KE, LS, MW, MZ, SD, SL, SZ, TZ, UG, ZM, ZW), Eurasian patent (AM, AZ, BY, KG, KZ, MD, RU, TJ, TM), European patent (AT, BE, BG, CH, CY, CZ, DE, DK, EE, ES, FI, FR, GB, GR, HU, IE, IT, LU, MC, NL, PT, RO, SE, SI, SK, TR), OAPI patent (BF, BJ, CF, CG, CI, CM, GA, GN, GQ, GW, ML, MR, NE, SN, TD, TG).

- (71) Applicant and  
(72) Inventor: **KAYAN, Helmut** [US/US]; 222 Scenic Drive, Redwood City, CA 94062 (US).
- (74) Agents: **AUDET, Paul, R.**; Tyco Healthcare Group LP, 150 Glover Avenue, Norwalk, CT 06856 et al. (US).

**Published:**  
— without international search report and to be republished upon receipt of that report

*For two-letter codes and other abbreviations, refer to the "Guidance Notes on Codes and Abbreviations" appearing at the beginning of each regular issue of the PCT Gazette.*

(54) Title: TACKING TOOL AND TACK

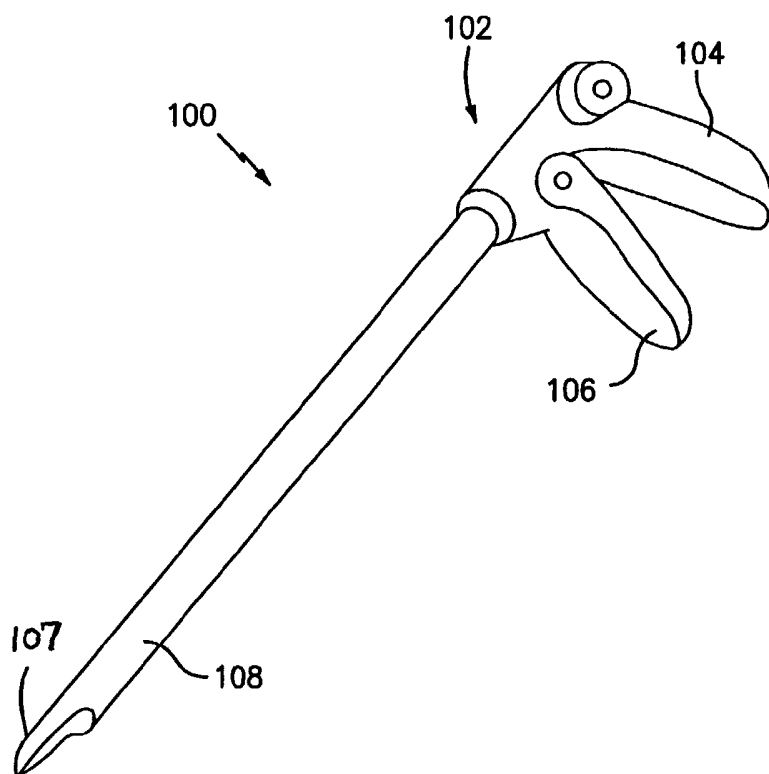

(57) Abstract: A surgical tacking apparatus for forming and applying surgical fasteners during laparoscopic or endoscopic procedures is disclosed. It includes a housing having a handle, an elongated tubular portion extending from the housing, a wire advancer, and a wire shaping nose at its distal end. An annular fastener is also disclosed.



WO 03/088815 A2

## **TACKING TOOL AND TACK**

### **CROSS REFERENCE TO RELATED APPLICATIONS**

This application claims priority from and the benefits of United States provisional  
5 application no. 60/373,710 filed on April 17, 2002.

### **BACKGROUND**

#### 1. Technical Field

The present disclosure relates generally to surgical apparatus for fastening objects to  
body tissue and, more particularly, to a surgical tacking tool configured to apply a loop  
10 fastener to a surgical mesh and underlying tissue during surgical procedures to repair body  
tissue, such as hernia repair.

#### 2. Background of Related Art

A number of surgical procedures require instruments that are capable of applying a  
surgical fastener to tissue in order to form tissue connections or to secure objects to tissue.  
15 For example, during hernia repair it is often desirable to fasten a surgical mesh to the  
underlying body tissue. In certain hernias, such as direct or indirect inguinal hernias, a part of  
the intestine protrudes through a defect or an opening in the supporting abdominal wall to  
form a hernial sac. The opening can be repaired using an open surgery procedure in which a  
relatively large incision is made in the patient and the hernia is closed off outside the  
20 abdominal wall by suturing. Alternatively, a mesh is attached with sutures over the opening  
to provide reinforcement.

Less invasive surgical procedures are currently available for hernia repair. In  
laparoscopic procedures, surgery is performed in the abdomen through a small incision, while

in endoscopic procedures surgery is performed through narrow endoscopic tubes inserted through small incisions in the body. Laparoscopic and endoscopic procedures generally require long and narrow instruments capable of reaching deep within the body and configured to form a seal with the incision or tube through which they are inserted.

5           Currently, endoscopic techniques for hernia repair utilize fasteners, such as surgical staples or clips, to secure the mesh to the tissue in order to provide reinforcement to the repair and in order to provide structure for encouragement of tissue ingrowth. These staples or clips need to be compressed against the tissue and mesh in order to secure the two together thereby requiring a tool which is positioned on each side of the mesh and tissue in order to deform the  
10 staple or clip. Another type of fastener suited for use in affixing mesh to tissue, during procedures such as hernia repair, is a coil fastener having a helically coiled body portion terminating in a tissue penetrating tip, which helical fastener is screwed into the mesh and body tissue. An example of this type of fastener is disclosed in U.S. Patent No. 5,258,000. Thus, the need exists for an improved surgical fastening apparatus that applies a fastener to  
15 surgical mesh and body tissue for effectively securing the mesh to the body tissue.

It is an object of the present disclosure to provide a tacking tool for securing a tack to both surgical mesh and body tissue.

Another object of the present disclosure is to provide a tacking tool that can apply a tack linearly to both surgical mesh and body tissue.

## 20 **SUMMARY**

This invention is directed to a tacking apparatus for applying fasteners to body tissue that includes a housing, an actuation mechanism, a supply of an elongated wire, an elongated tubular portion having a proximal end and a distal end, the proximal end being in communication with the housing, and the distal end having a nose having an interior portion

adapted for shaping a length of the wire into an annular shape, a wire advancer for advancing the wire from the supply to and through the nose portion of the elongated tubular portion, the wire advancer being actuated by the actuation mechanism and cooperable with the wire shaping portion of the nose to shape the length of the wire into a annular shape, and a cutter  
5 for severing the annular shaped portion of the wire to form an annular fastener. The actuation mechanism can include a trigger operatively coupled to the housing. In one preferred embodiment, the interior portion of the nose can be concavely curved or may have a semi-circular configuration. The fastener can have a body that is substantially planar. The interior portion of the nose can be shaped to provide a fastener with an inwardly disposed  
10 end, and an outwardly disposed end that overlaps the inwardly disposed end. The cutter may be operatively coupled to the actuation mechanism, it can be adapted to provide the inwardly disposed end of the fastener with a sharp tip, and it may be adapted to sever the length of wire at or near the distal end of the nose of the tubular portion, to thereby form the annular  
15 fastener. Further still, the supply of wire can be a spool having an endless length of the wire wound thereon for providing a multitude of fasteners. The wire can be formed from a shape memory material. The tubular portion can be adapted to fit through a body incision for a laparoscopic procedure. The nose can include a divider having a channel to pass the wire to the shaping portion in the nose.

The invention is also directed to a tack for fastening surgical mesh to body tissue. The  
20 tack can include a biocompatible substantially planar annular wire body, the body having a first end and a second end, the first end being disposed inwardly of the second end and having a tip suitable for penetrating body tissue, and the second end being disposed outwardly of and overlapping the first end. The first end of the tack may be sharpened. In another embodiment of the tack, the wire may be formed from either a shape memory material or a bioabsorbable

material.

### **BRIEF DESCRIPTION OF THE DRAWINGS**

By way of example only, preferred embodiments of the disclosure will be described with reference to the accompanying drawings, in which:

5           FIG. 1 is a perspective view of a preferred embodiment of a surgical tacking tool according to the present disclosure;

            FIG. 2 is an enlarged perspective view of the distal tip of the surgical tacking tool shown in FIG. 1;

            FIG. 3 is a cross-sectional side elevational view with portions broken away as would  
10 be taken through a portion of the surgical tacking tool of FIG. 1;

            FIG. 4 is a front elevational view of a wire ring formed by the surgical tacking tool shown in FIG. 1;

            FIG. 5 is a side elevational view of the wire ring shown in FIG. 4; and

            FIG. 6 is a perspective view of an alternative embodiment of a housing portion for a  
15 surgical tacking tool in accordance with the present disclosure.

### **DETAILED DESCRIPTION OF PREFERRED EMBODIMENTS**

Referring now in detail to FIGS. 1-3, in which like reference numerals identify similar or identical elements, a surgical tacking apparatus or tool in accordance with the present disclosure is generally designated as 100. As used herein, the term “distal” refers to that  
20 portion of the tool, or component thereof which is further from the user while the term “proximal” refers to that portion of the tool or component thereof which is closer to the user.

Tacking tool 100 is configured to apply a ring fastener to tissue or to secure surgical mesh to tissue during surgical procedures such as hernia repair. Tacking tool 100 generally includes a housing 102 including a handle portion 104 extending from the housing 102.

Tacking tool 100 includes an actuation mechanism, e.g. a trigger 106 pivotally connected to housing 102, with a free end of trigger 106 being spaced from a free end of handle 104.

Tacking tool 100 also includes an elongated tubular portion 108 extending distally from housing 102. Elongated tubular portion 108 is preferably dimensioned to fit through

5 conventional laparoscopic incisions and respective 15 mm, 10 mm, and 5 mm trocar cannula structures. As seen in FIG. 2, a distal end 107 of the tubular portion 108 is provided with a hollow down turned semi-circular or arcuate nose 110 oriented along the longitudinal axis of tubular portion 108. Nose 110 preferably includes a divider 112 defining a channel 114 therethrough for channeling wire 132 to nose 110 (see FIG. 3).

10 Turning now to FIG. 3, the internal structure of elongated tubular portion 108 is shown in detail. Elongated tubular portion 108 includes a reciprocable wire advancer 116 internally disposed therewithin. Wire advancer 116 includes an elongated shaft, here shown as having a substantially circular body portion with an elongated flattened, or otherwise shaped surface portion 118 that defines a passage 120 between an inner surface of tubular

15 portion 108 and wire advancer 116. Wire advancer 116 includes structure for engaging and distally advancing wire 134, for example a plurality of teeth 122 formed along the periphery of wire advancer 116, preferably distally of flattened surface portion 118. While it is preferred that teeth 122 are formed near the distal end of wire advancer 116, it is envisioned that teeth 122 can be formed at any suitable location on or along wire advancer 116. The wire

20 may be advanced by other gripping or friction enhancing structures. These structures can be static, movable, rotatable, ratchet-like, indexing, etc. Preferably, wire advancer 116 is provided with a chamber 124 preferably in substantial transverse alignment with teeth 122, chamber 124 being opened along a side radially opposite to flattened surface 118 of wire advancer 116. Chamber 124 defines an elongated centrally disposed camming surface 126

that is more deeply internally or centrally disposed within wire advancer 116 near the surface's distal end and than its proximal end. A bearing structure 128 is disposed within chamber 124. Bearing structure 128 is sized to contact camming surface 126 near its distal end and to contact the inner surface of tubular portion 108. In this manner, as wire advancer 5 116 is advanced through elongated tubular portion 108, camming surface 126 rides along bearing structure 128 thereby pressing advancer 116 and teeth 122 oppositely, radially outward toward the inner surface of tubular portion 108. Although chamber 124 of this embodiment is shown disposed substantially transversely aligned with teeth 122, it is envisioned that chamber 124 can be formed at any suitable location along the length of wire 10 advancer 116 to effect engagement and advancement of wire 134. In addition, while a ball-like bearing structure is shown which is free to rotate longitudinally distally and proximally, it is envisioned that any shaped bearing structure, fixed or relatively moveable, can be employed

Elongated tubular portion 108 includes a cutter. Preferably, wire advancer 116 15 includes the cutter, 130, extending distally therefrom. Cutter 130 is configured and adapted for slidable engagement preferably along an elongated surface of divider 112 as wire advancer 116 is advanced distally through tubular portion 108. FIG. 3 shows wire advancer 116 in a proximal position. As cutter 130 moves distally along the distal end portion of divider 112, at or adjacent down turned nose 110 of tubular portion 108, cutter 130 shears through wire 134, 20 preferably where or near where it projects out of channel 114. Preferably, the shearing action forms a distal end 146 that facilitates ease of entry into the tissue. Preferably, distal end 146 is sharpened.

Tacking tool 100 includes a replaceable wire source or supply, here shown as wire spool 132 located within handle portion 104 and operatively coupled to wire advancer 116.

Wire spool 132 is provided with a straight "endless" surgical grade wire 134 wound thereon. By "endless" it is meant that wire 134 has ends, but is very long to provide a multitude of fasteners without replacing wire spool 132. Wire 134 is threaded through tubular portion 108 by passing wire 134 through passage 120, over teeth 122, preferably at least into channel 114.

5 From there, prior to use, wire 134 can be advanced further into channel 114, and prior to or even with the edge of nose 110 of tubular portion 108. In operation, wire advancer 116 is moved distally through tubular portion 108, such that camming surface 126 rides along bearing surface 128 and causes teeth 120 to grip wire 134, thereby advancing a selected portion or length of wire 134 through tubular portion 108 and out through nose 110. As wire  
10 134 is advanced along and out of nose 110, the interior concave portion 109 of nose 110, deforms wire 134 and causes it to turn arcuately 360° or more in onto itself forming an annular fastener, here shown as a wire loop or ring 136 (FIG. 4). Finally, as wire advancer 116 is advanced to its most distal position, cutter 130 shears through wire 134 preferably at or near where it exits channel 114, thereby separating wire ring 136 from the remainder of wire  
15 134. As seen in FIG. 3, prior to or as wire 134 is being advanced, nose 110 of tacking tool 100 is pressed into a suitable surgical mesh 138 and into underlying tissue 140. Thus, as wire ring 136 is formed, it fastens surgical mesh 138 to the underlying tissue 140. While wire 134 has been disclosed as being a straight wire wound on a spool, it is envisioned that a wire formed from a shape memory material and having a shape memory, e.g. Nitinol, can be used,  
20 which shape memory wire will automatically cause the wire to curve as it is ejected through nose 110 of tubular portion 108. If shape memory wire is employed that is restrained and predetermined to curve and form a ring as it is freed from a restraint, a curved nose may not be needed. The same applies if a temperature triggerable shape memory metal is employed and the tacking tool is employed at the triggering temperature, for example, by use of body



tissue temperature. It will be understood that wire 134 can be made of any suitable biocompatible material, for example, metals, metal alloys, shape memory or not, and polymeric materials, preferably bioabsorbable.

As shown in FIG. 3, to apply wire ring 136, nose 110 of tubular portion 108 is  
5 inserted into tissue 140 through mesh 138. Wire 134 is then advanced through tubular portion 108 and out of nose 110, beginning the formation of ring 136. As more wire 134 is advanced through nose 110, more of ring 136 is formed. As ring 136 is formed, a first, inwardly disposed end 146 of wire 134 first penetrates through tissue 140, and follows an arcuate path as it exits tissue 140, passes into the underside of surgical mesh 138, and then  
10 distally back through surgical mesh 138 and back into tissue 140, thereby completing the formation of wire ring 136 and the fastening of mesh 138 to tissue 140.

In a preferred embodiment, one complete squeeze of trigger 106 will result in the formation of a complete wire ring 136. In order to ensure that a complete wire ring 136 is formed with the squeezing of trigger 106, preferably a latch and pawl mechanism (not shown)  
15 is provided in the handle 102. In operation, as trigger 106 is squeezed wire advancer 116 is moved distally through tubular portion 108 thereby commencing the formation of wire ring 136. Once trigger 106 is depressed slightly, the latch and pawl mechanism is configured to prohibit trigger 106 from backstroking until trigger 106 has been completely depressed and wire ring 136 is completely formed. Upon complete depression of trigger 106, the pawl  
20 clears the gear teeth (not shown) and the pawl rotates away from the teeth due to a spring biasing (not shown), thereby allowing trigger 106 to return to its unsqueezed or undepressed condition.

Upon complete depression of trigger 106, wire advancer 116 travels a predetermined distance through tubular portion 108, causing wire 134 to be ejected a predetermined amount

or length which is substantially equal to the circumference of wire ring 136 thereby resulting in the formation of a complete wire ring 136. Moreover, where trigger 106 is only partially depressed, the spring-loaded pawl (not shown) operates to hold trigger 106 stationary and will continue to function to hold trigger 106 stationary until trigger 106 has been completely  
5 depressed. In this way, the formation of wire ring 136 into body tissue 140 and surgical mesh 138 is controlled so that a single wire ring 136 at a time may be completely formed and fastened to body tissue 140 and surgical mesh 138. The above arrangement prevents formation of only partly formed fasteners.

In FIGS. 4 and 5, wire ring 136 is further shown and described. Wire ring 136  
10 includes a body portion 142 preferably having a first, inwardly disposed end 146 and a second outwardly disposed trailing end 144. As seen in FIG. 4, after formation of a complete wire ring 136, sharpened end 146 underlaps (laps radially inside of) second trailing end 144. It is envisioned, however, that depending on the radius and extent or length of curvature of the shaping portion of nose 110 of tubular portion 108, trailing end 144 can be made to overlap  
15 leading end 146, or leading end 146 can be made to overlap trailing end 144. As seen in FIG. 5, after complete formation, wire ring 136 is substantially planar (i.e., proximal end 144 and distal end 146 lie on the same plane with one another). Further, it is seen in FIG. 5 that wire 134 making up wire ring 136 has a circular cross section. However, it is envisioned that any suitable cross-sectional shape or configuration of the wire can be used to form wire ring 136  
20 although a wire having a cross section without sharpened edges is preferred in order to eliminate the possibility of the sharpened edges cutting into the tissue or cutting through the surgical mesh.

Turning now to FIG. 6, an alternative embodiment of a tacking tool according to the present disclosure is generally shown as 200. Tacking tool 200 includes a handle or a

housing 202 and a tubular portion 204 projecting from a distal end thereof. The housing 202 includes a handle portion 206 and a trigger 208 slidably coupled thereto and spaced a distance from the handle portion 206. Housing 202 further includes a dual rack and pinion arrangement wherein a pinion 210 is pivotably coupled to housing 202, a lower rack 212 is  
5 pivotably coupled to the trigger 208 and slidably coupled to the handle portion 206, and an upper rack 214 being slidably coupled to housing 202 and rigidly coupled to wire advancer 116 (not shown in FIG. 6, see FIG. 3). In this manner, as trigger 208 is depressed, lower rack 212 is moved proximally thereby rotating pinion 210 counter clockwise which in turn moves upper rack 214 and wire advancer 116 distally. Tacking tool 200 forms a wire ring 136 in the  
10 same manner as tacking tool 100.

Tacking tool 200 can be provided with a spool 232 of wire and a latch and pawl mechanism (not shown), like that employed in tacking tool 100, which limits movement of trigger 208 in a distal direction until a complete wire ring 136 is formed, at which time the pawl can be released and trigger 208 allowed to return to its distalmost position.

15 It is envisioned that the tacking tools disclosed herein can be adapted to be activated and operated remotely, for example robotically. In such instances, for example, the activation mechanism can be located and operated from a remote control box. The same can apply to the wire supply.

It will be understood that various modifications may be made to the embodiments  
20 disclosed herein. Therefore, the above description should not be construed as limiting, but merely as an exemplification of preferred embodiments. Those skilled in the art will envision other modifications within the scope and spirit of the claims appended hereto.

**WHAT IS CLAIMED IS:**

1. A tacking apparatus for applying fasteners to body tissue comprising:  
a housing;  
an actuation mechanism;  
5 a supply of an elongated wire;  
an elongated tubular portion having a proximal end and a distal end, the proximal end being in communication with the housing, and the distal end having a nose having an interior portion adapted for shaping a length of the wire into an annular shape;  
a wire advancer for advancing the wire from the supply to and through the nose  
10 portion of the elongated tubular portion, the wire advancer being actuated by the actuation mechanism and cooperable with the wire shaping portion of the nose to shape the length of the wire into a annular shape; and  
a cutter for severing the annular shaped portion of the wire to form an annular fastener.  
15
2. The tacking apparatus of claim 1, wherein the actuation mechanism includes a trigger operatively coupled to the housing.
3. The tacking apparatus of claim 1, wherein the interior portion of the nose is concavely curved.
4. The tacking apparatus of claim 1, wherein the interior portion of the nose has a  
20 semi-circular configuration.
5. The tacking apparatus of claim 3, wherein the fastener has a body that is substantially planar.
6. The tacking apparatus of claim 5, wherein the interior portion of the nose is shaped to provide a fastener with an inwardly disposed end, and an outwardly disposed end

that overlaps the inwardly disposed end.

7. The tacking apparatus of claim 6, wherein the cutter is adapted to provide the inwardly disposed end of the fastener with a sharp tip.

8. The tacking apparatus of claim 1, wherein the supply of wire is a spool having  
5 an endless length of the wire wound thereon for providing a multitude of fasteners.

9. The tacking apparatus of claim 1, wherein the cutter is operatively coupled to the actuation mechanism.

10. The tacking apparatus of claim 1, wherein the wire is formed from a shape memory material.

10 11. The tacking apparatus of claim 1, wherein the tubular portion is adapted to fit through a body incision for a laparoscopic procedure.

12. The tacking apparatus of claim 1, wherein the cutter is adapted to sever the length of wire at or near the distal end of the nose of the tubular portion, to thereby form the annular fastener.

15 13. The tacking apparatus of claim 12, wherein the nose includes a divider having a channel to pass the wire to the shaping portion in the nose.

14. A tack for fastening surgical mesh to body tissue, comprising:  
a biocompatible substantially planar annular wire body, the body having a first end and a second end, the first end being disposed inwardly of the second end and having a  
20 tip suitable for penetrating body tissue, and the second end being disposed outwardly of and overlapping the first end.

15. The tack of claim 14, wherein the tip of the first end is sharpened.

16. The tack of claim 14, wherein the wire is comprised of a shape memory material.

17. The tack of claim 14, wherein the wire is comprised of a bioabsorbable material.

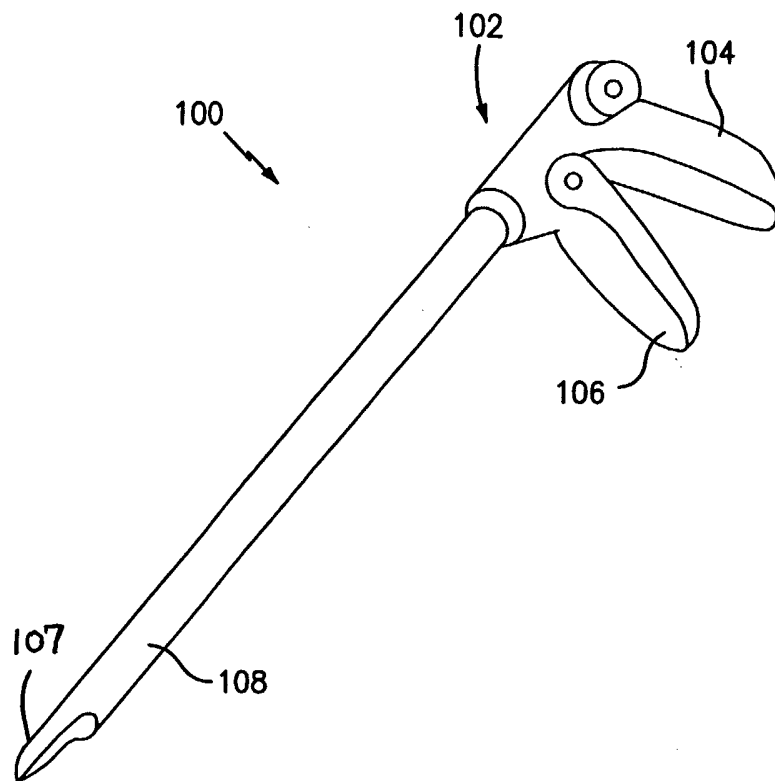

**FIG. 1**

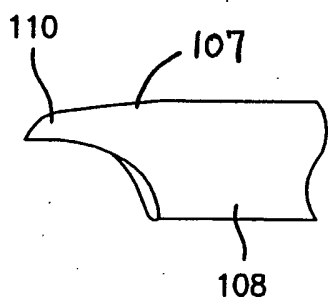

**FIG. 2**

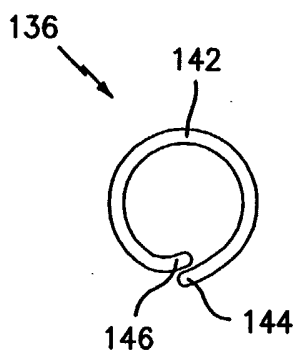

**FIG. 4**

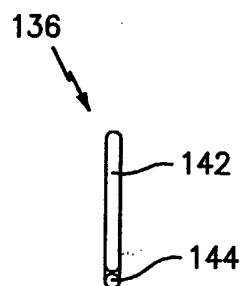

**FIG. 5**

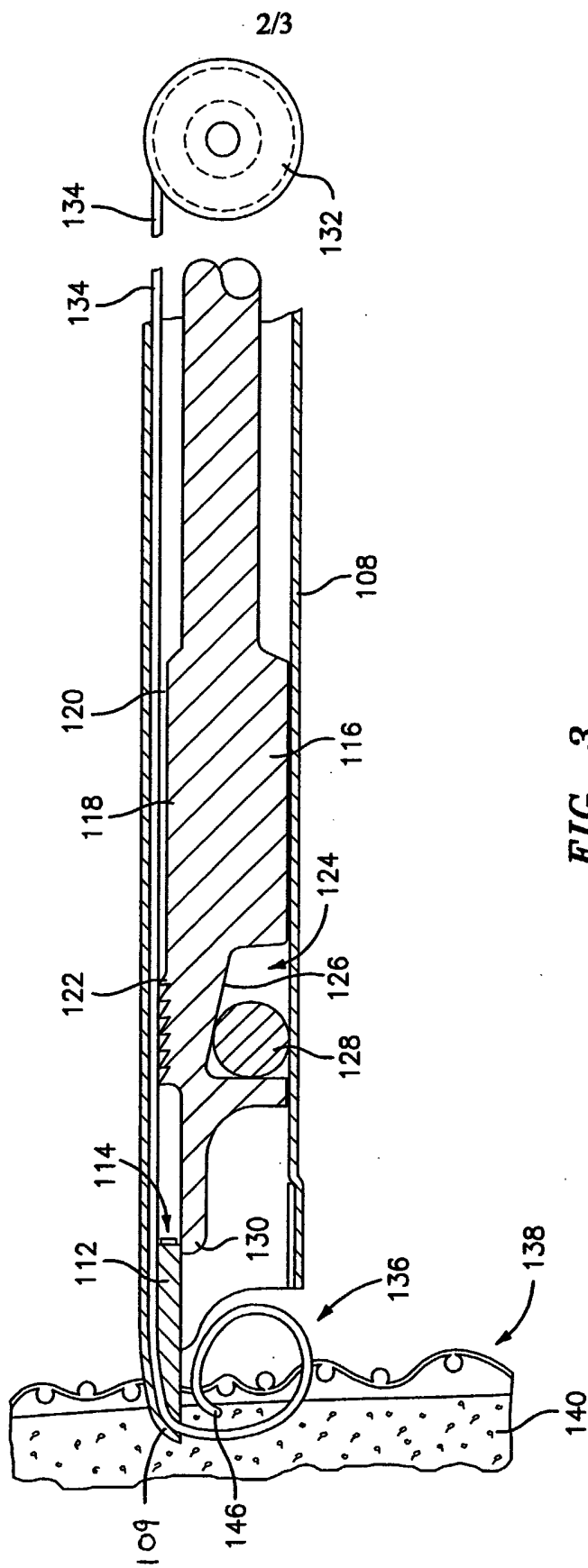
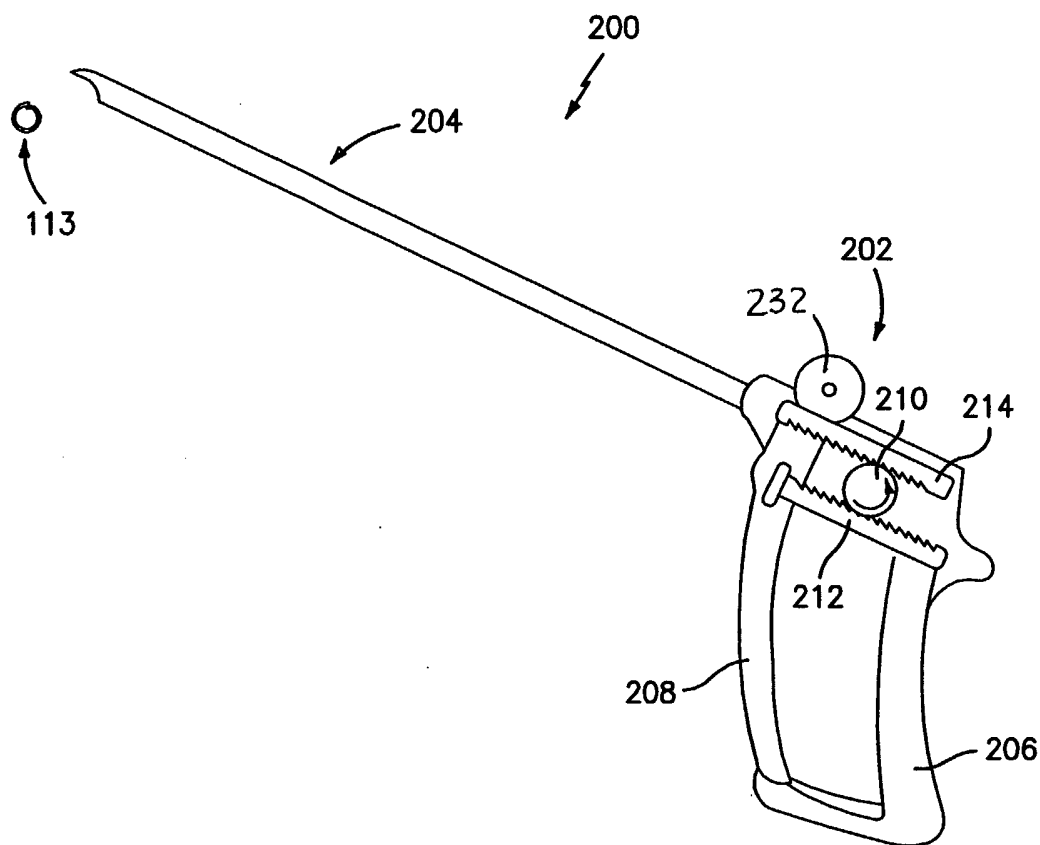

FIG. 3





**FIG. 6**