



US005834325A

United States Patent [19]

[11] Patent Number: **5,834,325**

Motoki et al.

[45] Date of Patent: **Nov. 10, 1998**

[54] **LIGHT EMITTING DEVICE, WAFER FOR LIGHT EMITTING DEVICE, AND METHOD OF PREPARING THE SAME**

5,281,830	1/1994	Kotaki et al.	257/86
5,369,289	11/1994	Tamaki et al.	257/99
5,408,120	4/1995	Manabe et al.	257/431
5,432,808	7/1995	Hatano et al.	372/45
5,496,766	3/1996	Amano et al.	437/127
5,578,839	11/1996	Nakamura et al.	257/96
5,665,986	9/1997	Miura et al.	257/96

[75] Inventors: **Kensaku Motoki; Mitsuru Shimazu; Yoshiki Miura**, all of Hyogo, Japan

[73] Assignee: **Sumitomo Electric Industries, Ltd.**, Osaka, Japan

FOREIGN PATENT DOCUMENTS

360140771	7/1985	Japan	438/287
8-181070	7/1996	Japan .	

[21] Appl. No.: **864,417**

[22] Filed: **May 28, 1997**

[30] Foreign Application Priority Data

May 31, 1996	[JP]	Japan	8-137332
May 13, 1997	[JP]	Japan	9-122378

[51] **Int. Cl.⁶** **H01L 21/00**

[52] **U.S. Cl.** **438/22; 438/29; 438/33; 438/46; 438/796; 148/DIG. 113; 257/13**

[58] **Field of Search** **438/22, 33, 46, 438/29, 796, 139, 287, 386; 257/13**

[56] References Cited

U.S. PATENT DOCUMENTS

5,278,433	1/1994	Manabe et al.	257/103
-----------	--------	--------------------	---------

Primary Examiner—John Niebling
Assistant Examiner—Long Pham
Attorney, Agent, or Firm—W. F. Fasse; W. G. Fasse

[57] ABSTRACT

A light emitting device having higher blue luminance is obtained. A gallium nitride compound layer is formed on a GaAs substrate, and thereafter the GaAs substrate is at least partially removed for forming the light emitting device. Due to the removal of the GaAs substrate, the quantity of light absorption is reduced as compared with the case of leaving the overall GaAs substrate. Thus, a light emitting device having high blue luminance is obtained.

10 Claims, 3 Drawing Sheets

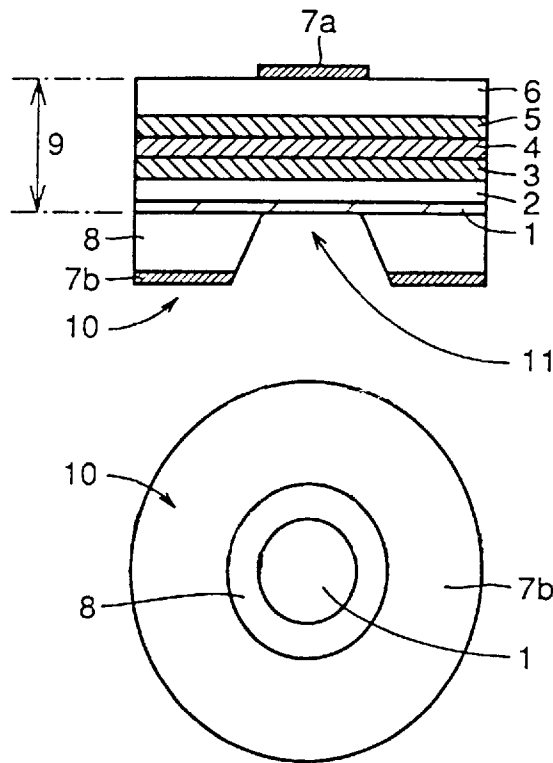

FIG. 1A

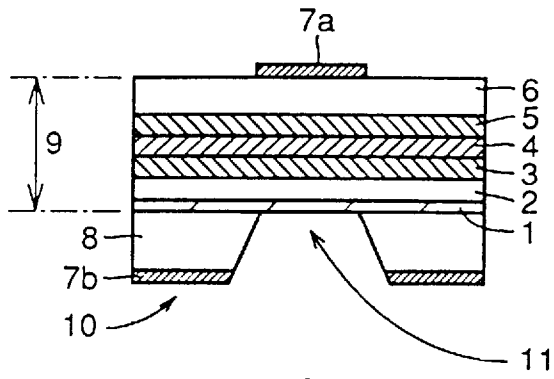

FIG. 1B

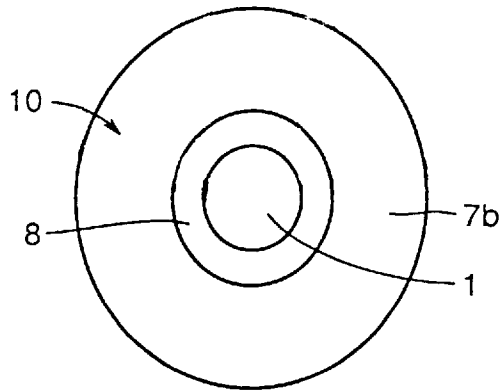

FIG. 2

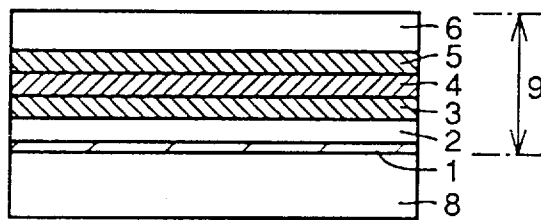

FIG.3

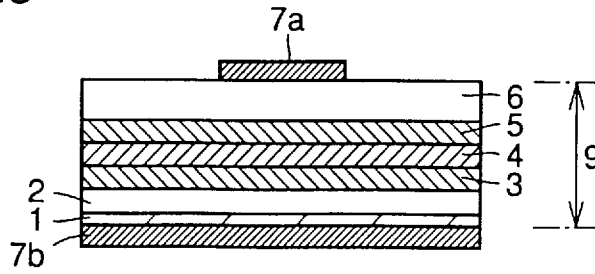

FIG.4

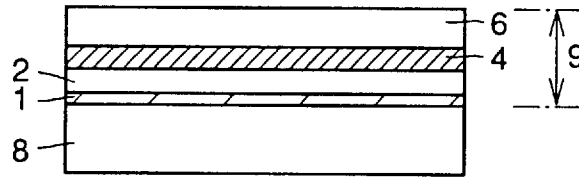

FIG.5

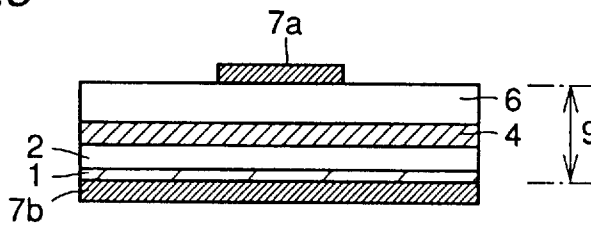
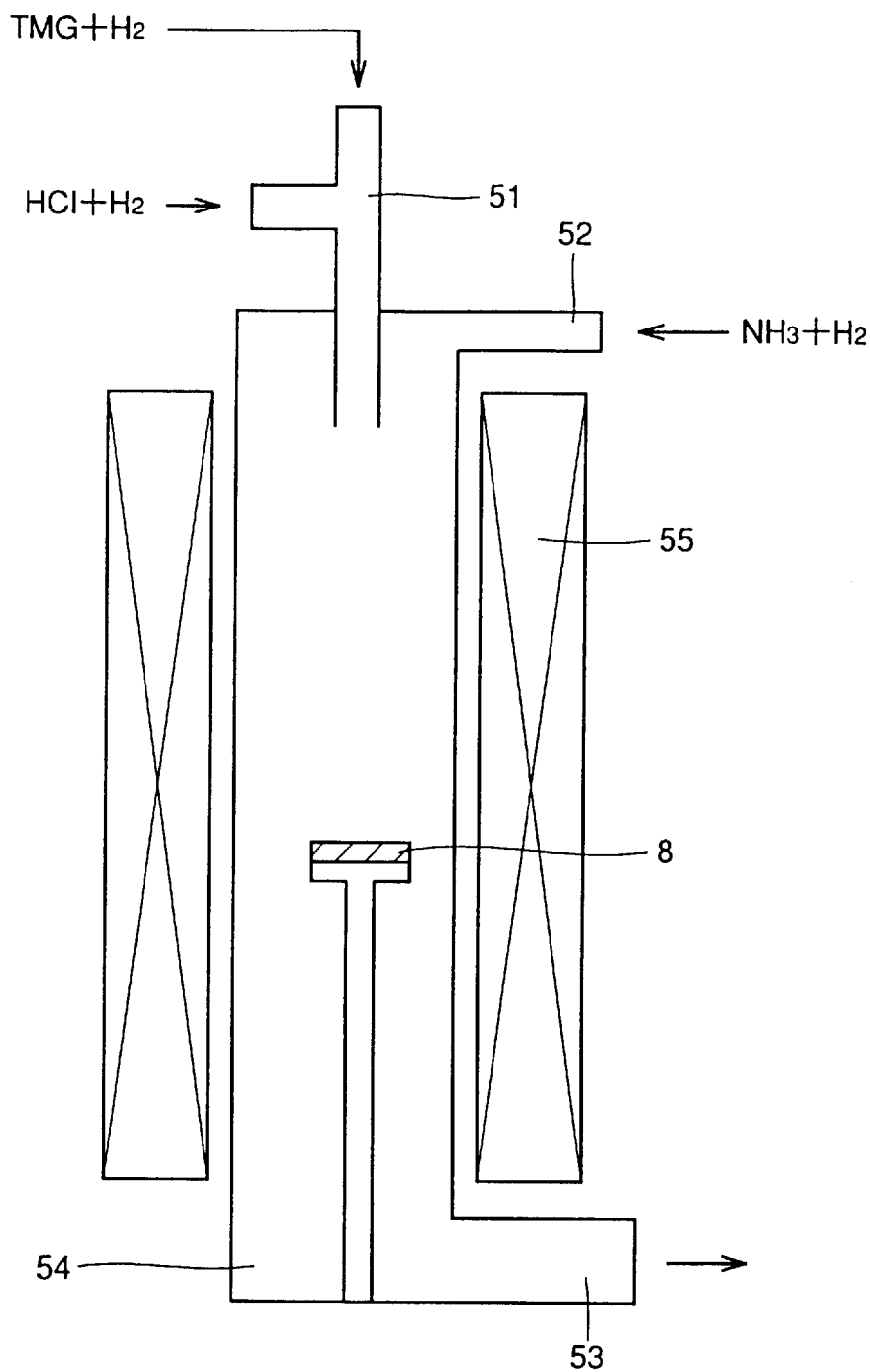

FIG. 6



LIGHT EMITTING DEVICE, WAFER FOR LIGHT EMITTING DEVICE, AND METHOD OF PREPARING THE SAME

BACKGROUND OF THE INVENTION

1. Field of the Invention

The present invention relates to a light emitting device, a wafer for a light emitting device, and a method of preparing the same, and more specifically, it relates to a light emitting device looking blue or blue-green, a wafer for a light emitting device and a method of preparing the same.

2. Description of the Background Art

In recent years, GaN light emitting devices are watched with interest. Among such light emitting devices, that employing a sapphire substrate is now being industrialized in particular. However, it is difficult to form a metal electrode on a lower portion of the sapphire substrate which is an insulating substrate. Therefore, a nitride mixed crystal must be extracted from an upper portion of the sapphire substrate by etching for forming a metal electrode, leading to complicated preparation steps and a high cost.

Due to no cleavage of the sapphire substrate, further, a reflector consisting of a cleavage plane cannot be formed in application to a laser diode. To this end, there has generally been proposed a light emitting device employing a gallium arsenide (GaAs) substrate in place of the sapphire substrate having such disadvantages. For example, Japanese Patent Laying-Open No. 8-181070 (1996) discloses such a light emitting device.

However, such a light emitting device employing a GaAs substrate has large absorption for light of a shorter wavelength corresponding to blue. Therefore, light passing through the GaAs substrate is absorbed to disadvantageously reduce the luminance of the overall light emitting device. In general, factors deciding the luminance of a light emitting device include light extraction efficiency in the case of extracting light from a light extraction port of the light emitting device into the air. This light extraction efficiency is decided by factors based on light reflection in the crystal and absorption of the light into the crystal. When a GaAs substrate is employed, however, a light absorption coefficient (cm^{-1}) which is the latter factor exceeds 10,000 with respect to light having energy exceeding 1.48 eV, i.e., in excess of 100 times that of a general sapphire substrate. Therefore, the GaAs substrate disadvantageously presents larger absorption as compared with the sapphire substrate.

SUMMARY OF THE INVENTION

An object of the present invention is to provide a light emitting device and a wafer for a light emitting device having higher luminance.

Another object of the present invention is to readily prepare a wafer for a light emitting device having higher luminance in a method of preparing the wafer for a light emitting device.

In a method of preparing a wafer for a light emitting device according to an aspect of the present invention, a gallium nitride compound layer is formed on a gallium arsenide (GaAs) substrate. After the formation of the gallium nitride compound layer, the gallium arsenide substrate is at least partially removed. Due to such at least partial removal of the gallium arsenide substrate, the quantity of light absorbed by the gallium arsenide substrate is reduced as compared with the case of entirely leaving the gallium arsenide substrate. Consequently, a wafer for a light emitting device having higher luminance can be readily prepared.

The gallium nitride compound layer may include a GaN buffer layer and a GaN epitaxial layer, so that the GaAs substrate is entirely removed. In this case, the total thickness of the GaN buffer layer and the GaN epitaxial layer is preferably set to be at least $70\ \mu\text{m}$ and not more than $400\ \mu\text{m}$, and the GaN buffer layer and the GaN epitaxial layer form a GaN substrate.

The gallium arsenide substrate may be removed by at least one of machine work removal means, removal means through reactive ion etching employing chlorine (Cl_2) gas, removal means through wet etching employing ammonia and hydrogen peroxide, and decomposition removal means in a high-temperature atmosphere of hydrogen chloride (HCl) gas. Further, the gallium nitride compound layer may include a gallium arsenide (GaAs) buffer layer, a first GaN epitaxial layer, a first aluminum gallium nitride (AlGaIn) epitaxial layer, a luminescent layer containing indium gallium arsenide (InGaAs), a second aluminum gallium nitride (AlGaIn) epitaxial layer, and a second GaN epitaxial layer. In this case, the gallium nitride compound layer may have a thickness of at least $70\ \mu\text{m}$ and not more than $200\ \mu\text{m}$, so that the gallium arsenide substrate is entirely removed. Alternatively, the gallium nitride compound layer may be formed to have a thickness of at least $1\ \mu\text{m}$ and not more than $70\ \mu\text{m}$, so that the gallium arsenide substrate is partially removed.

The step of forming the gallium nitride layer may include steps of forming a stripe pattern consisting of an insulating film on the GaAs substrate, thereafter forming a buffer layer consisting of either GaN or AlN on the GaAs substrate and the stripe pattern, and forming a GaN epitaxial layer on the buffer layer, while the step of at least partially removing the GaAs substrate may include a step of entirely removing the GaAs substrate. Due to the employment of the stripe pattern consisting of the insulating film, the formed buffer layer and GaN epitaxial layer can be improved in crystallinity. The insulating film is preferably prepared from either silicon dioxide or silicon nitride. The insulating film preferably has a width of at least $3\ \mu\text{m}$ and not more than $20\ \mu\text{m}$, and a thickness of at least $0.05\ \mu\text{m}$ and not more than $0.5\ \mu\text{m}$.

A wafer for a light emitting device according to another aspect of the present invention comprises a GaN substrate including a GaN buffer layer and a GaN epitaxial layer. The total thickness of the GaN buffer layer and the GaN epitaxial layer is at least $70\ \mu\text{m}$ and not more than $400\ \mu\text{m}$. In the wafer for a light emitting device according to this aspect, the GaN substrate including the GaN buffer layer and the GaN epitaxial layer can be employed for various applications. For example, the GaN substrate is effective as a substrate for a laser diode. Due to no presence of another type of substrate under the GaN buffer layer, a reflecting surface formed by cleavage on a chip end surface of a laser unit can be extremely smoothed, whereby the laser characteristics can be improved.

A light emitting device according to still another aspect of the present invention comprises a gallium arsenide substrate and a gallium nitride compound layer. The gallium arsenide substrate has a major surface. The gallium nitride compound layer is formed on the major surface of the gallium arsenide substrate, and includes a blue or blue-green luminescent layer. This gallium nitride compound layer includes a gallium nitride buffer layer, a first GaN epitaxial layer, a first aluminum gallium nitride epitaxial layer, a luminescent layer containing indium gallium nitride, a second aluminum gallium nitride epitaxial layer, and a second GaN epitaxial layer. Further, the gallium arsenide substrate is partially removed to expose a surface of the gallium nitride com-

pound layer. In the light emitting device according to this aspect, the surface of the gallium nitride compound layer is exposed by partially removing the gallium arsenide substrate, whereby the quantity of absorption of shorter-wavelength light corresponding to blue is reduced as compared with the case of entirely leaving the gallium arsenide substrate. Thus, a light emitting device having higher luminance can be obtained. In this case, the thickness of the gallium nitride compound layer forming the light emitting device is preferably set to be at least $1\ \mu\text{m}$ and not more than $70\ \mu\text{m}$.

The foregoing and other objects, features, aspects and advantages of the present invention will become more apparent from the following detailed description of the present invention when taken in conjunction with the accompanying drawings.

BRIEF DESCRIPTION OF THE DRAWINGS

FIG. 1A is a sectional view showing a light emitting device according to a first embodiment of the present invention, and FIG. 1B is a bottom plan view of the light emitting device shown in FIG. 1A;

FIG. 2 is a sectional view for illustrating a process of preparing an epitaxial wafer employed for a light emitting device according to the first or second embodiment of the present invention;

FIG. 3 is a sectional view showing the light emitting device according to the second embodiment of the present invention;

FIG. 4 is a sectional view for illustrating a process of preparing an epitaxial wafer employed for a light emitting device according to a third embodiment of the present invention;

FIG. 5 is a sectional view showing the light emitting device according to the third embodiment of the present invention; and FIG. 6 schematically illustrates the structure of a vapor deposition device employed for forming a compound semiconductor epitaxial layer according to the present invention.

DESCRIPTION OF THE PREFERRED EMBODIMENTS

Embodiments of the present invention are now described with reference to the drawings.

(First Embodiment)

Referring to FIGS. 1A and 1B showing a light emitting device according to a first embodiment of the present invention, a nitride mixed crystal layer 9 of a gallium nitride compound is formed on a surface of a GaAs substrate 8, and a metal electrode 7b is formed on another surface of the GaAs substrate 8. Further, a metal electrode 7a is formed on an upper surface of the nitride mixed crystal layer 9.

The nitride mixed crystal layer 9 includes six layers of a GaN buffer layer 1, an n-type GaN epitaxial layer 2, an n-type AlGa_N epitaxial layer 3, an InGa_N luminescent layer 4, a p-type AlGa_N epitaxial layer 5, and a p-type GaN epitaxial layer 6. This nitride mixed crystal layer 9 has such a double heterostructure that both surfaces of the InGa_N luminescent layer 4 are held between the AlGa_N epitaxial layers 3 and 5 serving as clad layers. Further, the n- and p-type GaN epitaxial layers 2 and 6 serve as protective films in an etching step. The n- and p-type GaN epitaxial layers 2 and 6 are superior in corrosion resistance to the n- and p-type AlGa_N epitaxial layers 3 and 5 serving as clad layers.

According to the first embodiment, the GaAs substrate 8 is so partially removed as to expose a surface of the GaN

buffer layer 1 on the removed portion. The metal electrode 7b is formed on a surface of an unremoved portion 10 of the GaAs substrate 8.

Due to the partial removal of the GaAs substrate 8 in the first embodiment, the quantity of light absorbed by the GaAs substrate 8 is reduced as compared with a conventional light emitting device provided with such a GaAs substrate on the overall surface. Thus, a light emitting device having higher luminance as compared with the prior art can be provided.

According to the first embodiment, the thickness of the nitride mixed crystal layer 9 is set to be at least $1\ \mu\text{m}$ and not more than $70\ \mu\text{m}$. The nitride mixed crystal layer 9 is thus formed in a relatively small thickness, since the strength can be maintained by the unremoved portion 10 of the GaAs substrate 8. According to the first embodiment, therefore, it is possible to provide a light emitting device employing the relatively thin nitride mixed crystal layer 9 at a low cost. The unremoved portion 10 of the GaAs substrate 8 must be formed in the minimum area with no hindrance on the luminescent portion.

Except the GaN epitaxial layers 2 and 6, each layer forming the nitride mixed crystal layer 9 has a small thickness of 0.1 to 0.2 μm . In practice, therefore, the thickness of the nitride mixed crystal layer 9 is substantially identical to the total thickness of the GaN epitaxial layers 2 and 6. In order to increase the thickness of the nitride mixed crystal layer 9, therefore, the thicknesses of the GaN epitaxial layers 2 and 6 may be increased. The thicknesses of the n- and p-type AlGa_N epitaxial layers 3 and 5 serving as clad layers for holding the InGa_N luminescent layer 4 may also be effectively increased for increasing the strength.

With reference to FIGS. 2 and 6, a process of preparing an epitaxial semiconductor wafer employed for the light emitting device according to the first embodiment shown in FIGS. 1A and 1B is now described. First, a vapor deposition device employed for preparing the epitaxial wafer through metal-organic chloride vapor phase epitaxy (MOCVPE) is described with reference to FIG. 6. This device is formed by a reaction chamber 54 having first and second gas inlet ports 51 and 52 and an exhaust port 53, and a resistance heater 55 for heating the overall reaction chamber 54 from its exterior. The epitaxial wafer shown in FIG. 2 is prepared through such a device. In more concrete terms, a GaAs (111) A-plane substrate 8 pretreated with an etching solution of hydrogen chloride (HCl) is set in the reaction chamber 54 consisting of quartz. The term "GaAs (111) A-plane substrate" indicates a substrate having a Ga surface on a GaAs (111) plane.

Then, the overall reaction chamber 54 is heated with the resistance heater 55 from the exterior, for holding the substrate 8 at 500° C. In this state, trimethyl gallium (TMG) and hydrogen chloride (HCl) are introduced from the first gas inlet port 51 as group III raw materials at partial pressures of 8×10^{-4} atm. and 8×10^{-4} atm. respectively. On the other hand, ammonia gas (NH₃) is introduced from the second gas inlet port 52 as a group V raw material at a partial pressure of 5.6×10^{-1} atm. Epitaxy is made for 15 minutes under such conditions, for forming a GaN buffer layer 1 having a thickness of 30 nm on the GaAs substrate 8.

Thereafter the resistance heater 55 heats the GaAs substrate 8 provided with the GaN buffer layer 1, for increasing its temperature to 850° C. Then, the partial pressures for TMG, HCl and NH₃ are set at 8×10^{-4} atm., 8×10^{-4} atm. and 1.6×10^{-1} atm. respectively, for making epitaxy for 100 minutes under such conditions. Thus, a hexagonal n-type GaN epitaxial layer 2 is formed on the GaN buffer layer 1.

Then, the temperature of the GaAs substrate 8 is maintained at 800° to 850° C. with the resistance heater 55, and

TMG, trimethyl aluminum (TMA), HCl and NH₃ are introduced under conditions equalizing partial pressures for TMG and TMA with each other, for making epitaxy for 10 minutes. Thus formed is an epitaxial layer **3** consisting of n-type Al_{0.1}Ga_{0.9}N.

Then, the temperature of the GaAs substrate **8** is reduced to the range of 500° to 700° C. with the resistance heater **55**. Thereafter TMG, trimethyl indium (TMI), HCl and NH₃ are introduced under such conditions that the partial pressure for TMI is 20 times that for TMG, for making epitaxy for 10 minutes. Thus formed is a luminescent layer **4** consisting of In_{0.3}Ga_{0.7}N.

Then, the conditions are returned to those for forming the epitaxial layer **3** consisting of n-type Al_{0.1}Ga_{0.9}N, for forming an epitaxial layer **5** consisting of p-type Al_{0.1}Ga_{0.9}N similarly to the above. The epitaxial layers **3** and **5** serve as clad layers holding the luminescent layer **4**.

A p-type GaN epitaxial layer **6** is grown on the p-type AlGa_N epitaxial layer **5** under the same conditions as those for forming the n-type GaN epitaxial layer **2**. Dopants introduced into the n- and p-type GaN layers **2** and **6** are prepared from silicon (Si) or sulfur (S) and magnesium (Mg) respectively. The InGa_N luminescent layer **4** is originally of an n-type. Epitaxy is completed at this point of time, and the substrate **8** is temporarily taken out from the furnace. Then, a surface of the GaAs substrate **8** which is opposite to that provided with the epitaxial layers is ground with a grinder. Due to this grinding, the thickness of the GaAs substrate **8**, which is originally 600 μm, is reduced to about 100 μm.

Thereafter SiO₂ films each having a thickness of 300 nm are formed on upper and lower surfaces respectively by plasma chemical vapor deposition (plasma CVD). Then, the SiO₂ films are patterned through photolithography. The patterned SiO₂ films are employed for masking.

In more concrete terms, a portion of the GaAs substrate **8** not masked with the SiO₂ films is removed by a reactive etching device (not shown). The reactive etching device is generally provided with a flat electrode which is connected with a high-frequency power source and a counter electrode opposed to the flat electrode. This reactive etching device comprises a gas inlet system for introducing a reactive gas and an exhaust system for maintaining the pressure in an etching chamber at a constant level. In case of carrying out etching, the wafer is arranged on the flat electrode to which high-frequency power is applied, and a plasma is generated between the flat and counter electrodes. Ions of the reactive gas are vertically incident upon the wafer surface along a vertical electric field across the electrodes, for etching the wafer surface in the vertical direction. In this case, Cl₂ gas is fed as the reactive gas. The total pressure and the high-frequency power (frequency: 13.56 MHz) for generating the plasma are set at 1.3×10⁻³ atm. and 150 W respectively, for etching the GaAs substrate **8**.

Thus, the GaAs substrate **8** is partially removed by the reactive ion etching device through the masks of the SiO₂ films. Thereafter the SiO₂ films are removed and an ohmic metal electrode **7b** is vapor-deposited on a surface of the portion of the GaAs substrate **8** from which the SiO₂ films are removed. At the same time, a metal electrode **7a** is vapor-deposited also on a surface of the p-type GaN epitaxial layer **6**. Thus prepared is a double hetero light emitting device according to the first embodiment, as shown in FIGS. **1A** and **1B**.

(Second Embodiment)

With reference to FIGS. **2** and **3**, a light emitting device according to a second embodiment of the present invention

is now described. In the structure of the light emitting device according to the second embodiment, a GaAs substrate **8** is completely removed as shown in FIG. **3**, dissimilarly to the light emitting device according to the first embodiment shown in FIG. **1A**. In more concrete terms, a metal electrode **7b** is directly formed on a rear surface of a nitride mixed crystal layer **9**, and a metal electrode **7a** is also formed on a prescribed portion of an upper surface of the nitride mixed crystal layer **9**.

In the light emitting device according to the second embodiment, the nitride mixed crystal layer **9** includes six layers of a GaN buffer layer **1**, an n-type GaN epitaxial layer **2**, an n-type AlGa_N epitaxial layer **3**, an InGa_N luminescent layer **4**, a p-type AlGa_N epitaxial layer **5** and a p-type GaN epitaxial layer **6**, similarly to the structure of the light emitting device according to the first embodiment shown in FIG. **1A**. In the light emitting device according to the second embodiment shown in FIG. **3**, however, the GaAs substrate **8** is completely removed dissimilarly to the light emitting device according to the first embodiment, and hence the strength of the nitride mixed crystal layer **9** must be increased. In the light emitting device according to the second embodiment, therefore, the thickness of the nitride mixed crystal layer **9** is preferably set to be at least 70 μm and not more than 200 μm. The nitride mixed crystal layer **9** is weak in strength if the thickness is less than 70 μm, while the cost is excessively increased if the thickness is larger than 200 μm.

Except the GaN epitaxial layers **2** and **6**, each layer forming the nitride mixed crystal layer **9** has an extremely small thickness of 0.1 to 0.2 μm. In practice, therefore, the thickness of the nitride mixed crystal layer **9** is substantially identical to the total thickness of the GaN epitaxial layers **2** and **6**. In order to increase the thickness of the nitride mixed crystal layer **9**, therefore, it is effective to increase the thicknesses of the GaN epitaxial layers **2** and **6**. The thicknesses of the n- and p-type AlGa_N epitaxial layers **3** and **5** serving as clad layers for holding the InGa_N luminescent layer **4** may also be effectively increased for increasing the strength.

In the light emitting device according to the second embodiment shown in FIG. **3**, light absorption by GaAs can be prevented in light emission by completely removing the GaAs substrate **8**. Consequently, it is possible to provide a light emitting device having higher luminance as compared with that according to the first embodiment.

A process of preparing the light emitting device according to the second embodiment shown in FIG. **3** is now described. Similarly to the aforementioned process of preparing the light emitting device according to the first embodiment, a GaN buffer layer **1** is formed on a GaAs (111) A-plane substrate **8**, as shown in FIG. **2**. The GaN buffer layer **1** has an extremely small thickness of not more than 1 μm. Therefore, the GaN buffer layer **1** does not much contribute to the thickness of the nitride mixed crystal layer **9**. Then, the temperature of the GaAs substrate **8** provided with the GaN buffer layer **1** is increased to 850° C. with a resistance heater **55**. Thereafter partial pressures for TMG, HCl and NH₃ are set at 8×10⁻⁴ atm., 8×10⁻⁴ atm. and 1.6×10⁻¹ atm. respectively, for making epitaxy under such conditions. Thus formed is a hexagonal n-type GaN epitaxial layer **2** having a thickness of about 40 μm.

Then, the temperature of the GaAs substrate **8** is maintained at 800° to 850° C. with the resistance heater **55**. Then, TMG, TMA, HCl and NH₃ are introduced under conditions equalizing partial pressures for TMG and TMA with each

other. Epitaxy is made for 10 minutes in this state. Consequently formed is an epitaxial layer **3** consisting of n-type $\text{Al}_{0.1}\text{Ga}_{0.9}\text{N}$.

Then, the temperature of the GaAs substrate **8** is reduced to the range of 500° to 700° C. with the resistance heater **55**. Thereafter TMG, TMI, HCl and NH_3 are introduced under such conditions that the partial pressure for TMI is 20 times that for TMG, for making epitaxy for 10 minutes. Thus formed is a luminescent layer **4** consisting of $\text{In}_{0.3}\text{Ga}_{0.7}\text{N}$.

Thereafter the conditions are returned to those for forming the epitaxial layer **3** consisting of n-type $\text{Al}_{0.1}\text{Ga}_{0.9}\text{N}$, for forming an epitaxial layer **5** consisting of p-type $\text{Al}_{0.1}\text{Ga}_{0.9}\text{N}$ similarly to the above. The n- and p-type epitaxial layers **3** and **5** serve as clad layers holding the luminescent layer **4**.

A p-type GaN epitaxial layer **6** is grown on the p-type AlGaN epitaxial layer **5** under conditions similar to those for forming the n-type GaN epitaxial layer **2**. Epitaxy is completed in this stage, and the GaAs substrate **8** is temporarily taken out from the furnace. Then, a surface of the GaAs substrate **8** which is opposite to that provided with the epitaxial layers is ground with a grinder. Due to this grinding, the thickness of the GaAs substrate **8**, which is originally $600\ \mu\text{m}$, is reduced to about $100\ \mu\text{m}$.

Thereafter the GaAs substrate **8** is set in a furnace dedicated to etching. In this etching furnace, hydrogen gas is employed as a carrier gas for feeding 10 sccm of hydrogen chloride under a normal pressure at a substrate temperature of 800° C. Thus, the GaAs substrate **8** is entirely removed by etching through thermal decomposition with no plasma. "10 sccm" indicates a flow rate of 10 cc per minute at 0° C. and 1 atm.

Thus, the GaAs substrate **8** is removed by etching, thereby forming an epitaxial wafer consisting of only the nitride mixed crystal layer **9**. When the GaAs substrate **8** is removed in the aforementioned manner, the etching time can be reduced by previously reducing the thickness of the GaAs substrate **8** to about $100\ \mu\text{m}$ with a grinder and thereafter performing etching. Thus, damage of the nitride mixed crystal layer **9** caused by the etching can be reduced.

Then, ohmic metal electrodes **7** are vapor-deposited on upper and lower surfaces of the nitride mixed crystal layer **9** respectively, and the epitaxial wafer is cut into the size of a light emitting device. Thus, it is possible to prepare a double hetero light emitting device according to the second embodiment having the AlGaN epitaxial layers **3** and **5** serving as clad layers, as shown in FIG. **3**. The overall thickness of the nitride mixed crystal layer **9** shown in FIG. **3** is set at about $200\ \mu\text{m}$. Thus, it is possible to provide a light emitting device which is stable in strength.

The GaAs substrate **8** may conceivably be removed by reactive ion etching. In more concrete terms, the wafer for the light emitting device is formed in the state shown in FIG. **2**, and thereafter set in a reactive ion etching device. In the reactive etching device, Cl_2 gas is fed as a reactive gas, and the total pressure and high-frequency power for generating a plasma are set at 1.3×10^{-3} atm. and 150 W at 13.56 MHz respectively, for etching the GaAs substrate **8**. Thereafter the ohmic metal electrodes **7a** and **7b** are vapor-deposited on the upper and lower surfaces of the GaAs substrate **8** respectively, as shown in FIG. **3**. Then, the epitaxial wafer is cut into the size of the light emitting device, thereby forming the double hetero light emitting device.

An effect similar to the above can be attained also with a mixed gas of Cl_2 and H_2 for the reactive ion etching. In this case, etching can be effectively performed with a gas total pressure of 1.3×10^{-4} atm. and high-frequency power of 50 to 300 W at 13.56 MHz for generating the plasma.

(Third Embodiment)

A light emitting device according to a third embodiment of the present invention is now described with reference to FIGS. **4** and **5**. Referring to FIG. **5**, a nitride mixed crystal layer **9** is formed by four layers of a GaN buffer layer **1**, an n-type GaN epitaxial layer **2**, an InGaN luminescent layer **4** and a p-type GaN epitaxial layer **6** in the light emitting device according to the third embodiment, dissimilarly to those according to the first and second embodiments. Metal electrodes **7a** and **7b** are formed on upper and lower surfaces of such a nitride mixed crystal layer **9** respectively. Also in the light emitting device according to the third embodiment, a GaAs substrate **8** is completely removed in a process described later, so that no light is absorbed by the GaAs substrate **8**. Thus, it is possible to provide a light emitting device having higher luminance as compared with that according to the first embodiment shown in FIG. **1A**. The thickness of the nitride mixed crystal layer **9** is set at about $70\ \mu\text{m}$ in the third embodiment.

A process of preparing the light emitting device according to the third embodiment is now described with reference to FIGS. **4** and **5**.

First, an epitaxial wafer shown in FIG. **4** is formed with the vapor deposition device shown in FIG. **6** described above with reference to the process according to the first embodiment. In more concrete terms, a GaAs (111) A-plane substrate **8** pretreated with an etching solution of hydrogen chloride (HCl) is set in the reaction chamber **54** consisting of quartz, as shown in FIG. **6**.

Then, the overall reaction chamber **54** is heated with a resistance heater **55** from the exterior, for maintaining the temperature of the GaAs substrate **8** at 500° C. In this state, trimethyl gallium (TMG) and hydrogen chloride (HCl) are introduced from the first gas inlet port **51** as group III raw materials at partial pressures of 8×10^{-4} atm. and 8×10^{-4} atm. respectively. On the other hand, ammonia gas (NH_3) is introduced from the second gas inlet port **52** as a group V raw material at a partial pressure of 5.6×10^{-1} atm. Epitaxy is made for 15 minutes under such conditions, for forming a GaN buffer layer **1** having a thickness of 30 nm on a surface of the GaAs substrate **8**.

Thereafter the resistance heater **55** heats the GaAs substrate **8** provided with the GaN buffer layer **1**, for increasing its temperature to 850° C. Thereafter the partial pressures for TMG, HCl and NH_3 are set at 8×10^{-4} atm., 8×10^{-4} atm. and 1.6×10^{-1} atm. respectively, for making epitaxy for 100 minutes under such conditions. Thus, a hexagonal n-type GaN epitaxial layer **2** having a thickness of $5\ \mu\text{m}$ is grown on the GaN buffer layer **1**.

Then, the temperature of the GaAs substrate **8** provided with the GaN buffer layer **1** and the n-type epitaxial layer **2** is reduced to the range of 500° to 700° C. with the resistance heater **55**. Thereafter TMG, TMI, HCl and NH_3 are introduced under such conditions that the partial pressure for TMI is 10 times that for TMG, for making epitaxy for 10 minutes. Thus formed is a luminescent layer **4** consisting of $\text{In}_{0.3}\text{Ga}_{0.7}\text{N}$.

Then, a p-type GaN epitaxial layer **6** is formed under the same conditions as those for forming the n-type GaN epitaxial layer **2**. Thus, the epitaxial wafer for the light emitting device is formed as shown in FIG. **4**.

Thereafter the epitaxial wafer for the light emitting device is taken out and set in a furnace dedicated to etching. In this etching furnace, hydrogen (H_2) gas is employed as a carrier gas for feeding 10 sccm of HCl under a normal pressure at a substrate temperature of 800° C. Thus, the GaAs substrate

8 is completely removed by etching. Consequently formed is the epitaxial wafer consisting of the nitride mixed crystal layer **9**, from which the GaAs substrate **8** is completely removed.

Thereafter ohmic metal electrodes **7a** and **7b** are vapor-deposited on upper and lower surfaces of such an epitaxial wafer respectively. Then, the epitaxial wafer is cut into the size of the light emitting device. Thus formed is a double hetero light emitting device according to the third embodiment, having the InGaN luminescent layer **4** held between the n- and p-type GaN epitaxial layers **2** and **6**, as shown in FIG. **5**. In this case, the nitride mixed crystal layer **9** is not much strong due to its thickness of about 70 μm . When a current was fed to a double hetero light emitting device according to the third embodiment formed in the aforementioned manner in practice, however, it was confirmed possible to obtain blue light emission which was brighter than that in the light emitting device employing the GaAs substrate **8**.

This light emission is weak with a small energy gap between the n- and p-type GaN epitaxial layers **2** and **6** serving as clad layers and the luminescent layer **4**. However, blue light emission is conceivably obtained due to complete removal of the GaAs substrate **8** absorbing light.

(Fourth Embodiment)

According to a fourth embodiment of the present invention, a GaAs (111) A-plane substrate **8** is first pretreated, and thereafter set in the reaction chamber **54** shown in FIG. **6**. Then, the GaAs (111) A-plane substrate **8** is heated with the resistance heater **55**, so that its temperature is maintained at 500° C. In this state, trimethyl gallium (TMG) and hydrogen chloride (HCl) are introduced from the first gas inlet port **51** at partial pressures of 8×10^{-4} atm. and 8×10^{-4} atm. respectively. On the other hand, ammonia gas (NH_3) is introduced from the second gas inlet port **52** at a partial pressure of 5×10^{-1} atm. Under such conditions, a GaN buffer layer of about 30 nm is grown on the GaAs substrate **8** for 15 minutes. Further, the GaAs substrate **8** is heated with the resistance heater **55**, so that its temperature is increased to 920° C. Thereafter the partial pressures for TMG, HCl and NH_3 are set at 2×10^{-3} atm., 2×10^{-3} atm. and 2×10^{-3} atm. respectively, for making epitaxy for 10 hours. Consequently, a GaN epitaxial layer of about 100 μm is grown on the GaN buffer layer. While cracks were found in such a GaN epitaxial layer prepared in practice, it was confirmed by X-ray crystal crystallographic analysis that this GaN epitaxial layer was a single-crystalline thick film of hexagonal GaN having a mirror surface.

Then, wet etching is performed for about 30 minutes in an etchant containing hydrogen peroxide water and ammonia at a volume ratio of 2:1, for entirely removing the GaAs substrate **8**. Thus, a GaN substrate consisting of the GaN buffer layer and the GaN epitaxial layer can be prepared. This GaN substrate can be used for various applications as a simple substance.

For example, this GaN substrate is effective as a substrate for a laser diode. In this GaN substrate having no substrate of another type under the GaN layer, a reflecting surface by cleavage on a chip end surface of a laser unit can be extremely smoothed, for remarkably improving the laser characteristics.

In a similar method to that according to the first embodiment, hetero epitaxy was made on a GaN substrate prepared in the aforementioned manner in practice. First, each of NH_3 , TMG and TMA was introduced onto a GaN epitaxial layer forming the GaN substrate by about 1.6×10^{-3}

atm., and grown at 850° C. for about 10 minutes, thereby forming an AlGaN layer. Thereafter TMI and TMG were fed at partial pressures of 4×10^{-4} atm. and 2×10^{-5} atm. respectively at 800° C. with NH_3 in the same flow rate as the above, thereby forming an epitaxial layer consisting of InGaN on the AlGaN layer. Further, another AlGaN layer was grown on the InGaN epitaxial layer in the same conditions as those for growing the aforementioned AlGaN layer. Thus, it was possible to form a double heterostructure on the GaN substrate. Then, a rear side of the GaN substrate was scribed with a diamond pen, for cleaving the same. Consequently, a mirror-faced cleavage plane was obtained, and it was confirmed that this laser diode was sufficient in flatness and parallelism for serving as a reflector.

A laser diode is generally provided with a reflector on an end surface of a substrate, to be based on end plane emission. It is said that cleavage of the substrate, i.e., flatness of the end plane decides the characteristics of the laser diode. When a general sapphire substrate is employed, cleavage cannot be satisfactorily made due to the difference between cleavage planes of the sapphire substrate and GaN. According to the present invention, both of the substrate and the epitaxial layer are of a GaN system due to presence of no substrate other than the GaN substrate, to enable remarkably preferable cleavage.

The GaN substrate consisting of the GaN buffer layer and the GaN epitaxial layer is preferably formed to have a thickness of at least 70 μm and not more than 400 μm . The upper limit is increased up to 400 μm , since a large thickness is preferable for employment as a single substrate.

(Fifth Embodiment)

According to a fifth embodiment of the present invention, a thin film of SiO_2 is first formed on a GaAs (111) A-plane substrate **8** in a thickness of about 100 nm by reactive sputtering. Thereafter a stripe resist pattern of about 5 μm width is formed on the SiO_2 film by photolithography. Thereafter the resist pattern is employed as a mask for removing portions of the SiO_2 film exposed through stripe windows of the resist pattern by reactive ion etching (RIE). Thereafter the resist pattern is removed, thereby preparing a GaAs (111) A-plane substrate **8** having a stripe pattern, consisting of SiO_2 , having a thickness of about 100 nm at pitches of about 5 μm .

Thereafter GaN is grown on the GaAs (111) A-plane substrate **8**, similarly to the aforementioned embodiments. In more concrete terms, the GaAs (111) A-plane substrate **8** is pretreated with an HCl etching solution, and thereafter set in the reaction chamber **54**. The GaAs (111) A-plane substrate **8** is heated with the resistance heater **55**, so that its temperature is maintained at about 500° C., similarly to the aforementioned embodiments. In this state, trimethyl gallium (TMG) and hydrogen chloride are introduced from the first gas inlet port **51** at partial pressures of 8×10^{-4} atm. and 8×10^{-4} atm. respectively. On the other hand, ammonia gas (NH_3) is introduced from the second gas inlet port **52** at a partial pressure of 5×10^{-1} atm. Under such conditions, a GaN buffer layer of about 30 nm is grown on the GaAs (111) A-plane substrate **8** for 15 minutes. Further, the GaAs (111) A-plane substrate **8** is heated with the resistance heater **55**, so that its temperature is increased to 920° C. Thereafter the partial pressures for TMG, HCl and NH_3 are set at 2×10^{-3} atm., 2×10^{-3} atm. and 2×10^{-1} atm. respectively, for making epitaxy for 10 hours. Consequently, a GaN epitaxial layer of about 100 μm is grown on the GaN buffer layer.

In an initial stage of the growth, the GaN epitaxial layer is not in the least grown on the SiO_2 film but selectively

grown only on the GaAs (111) A-plane substrate **8**. With progress of the growth, however, the thickness of the GaN epitaxial layer is increased, followed by lateral growth of the GaN epitaxial layer on the SiO₂ film. Thus, portions of the GaN epitaxial layer grown on the SiO₂ film from both sides are connected and integrated with each other. In practice, it has been confirmed by X-ray crystallographic analysis that a GaN epitaxial layer having a thickness of about 100 μm formed in the aforementioned manner was a hexagonal single-crystalline thick film having a mirror surface with no cracks.

Then, wet etching is performed for about 30 minutes in an etchant containing hydrogen peroxide water and ammonia at a ratio of 2:1, for entirely removing the GaAs (111) A-plane substrate **8**. Thus, a GaN substrate consisting of the GaN buffer layer and the GaN epitaxial layer can be prepared in a thickness of about 100 μm. This GaN substrate can be used for various applications as a simple substance. For example, this GaN substrate is effective as a substrate for a laser diode. In this GaN substrate having no substrate of another type under the GaN layer, a reflecting surface by cleavage on a chip end surface of a laser unit can be extremely smoothed, for remarkably improving the laser characteristics.

In practice, hetero epitaxy was made on a GaN substrate prepared in the aforementioned manner similarly to the first embodiment. First, NH₃ and each of TMG and TMA were introduced onto a GaN epitaxial layer forming the GaN substrate by 1.6×10^{-1} atm. and about 6×10^{-4} atm. respectively, and grown at 850° C. for about 10 minutes, thereby forming an AlGaIn layer. Thereafter TMI and TMG were fed at partial pressures of 4×10^{-4} atm. and 2×10^{-5} atm. respectively at 800° C. with NH₃ in the same flow rate as the above, thereby forming an epitaxial layer consisting of InGaIn on the AlGaIn layer. Further, another AlGaIn layer was grown on the InGaIn epitaxial layer in the same conditions as those for growing the aforementioned AlGaIn layer. Thus, it was possible to form a double heterostructure on the GaN substrate. Then, a rear side of the GaN substrate was scribed with a diamond pen, for cleaving the same. Consequently, a mirror-faced cleavage plane was obtained, and it was confirmed that this laser diode was sufficient in flatness and parallelism for serving as a reflector.

While the three-system AlGaIn epitaxial layers **3** and **5** of Ga, Al and N are employed as clad layers in each of the aforementioned first and second embodiments, the present invention is not restricted to this but four-system epitaxial layers of Ga, Al, In and N can be employed as clad layers. The InGaIn luminescent layer **4** conceivably emits light since such three- or four-system clad layers have larger energy band gaps as compared with the InGaIn luminescent layer.

Although the present invention has been described and illustrated in detail, it is clearly understood that the same is by way of illustration and example only and is not to be taken by way of limitation, the spirit and scope of the present invention being limited only by the terms of the appended claims.

What is claimed is:

1. A method of preparing a wafer for a light emitting device, comprising the steps of:

forming a gallium nitride compound layer on a GaAs substrate; and

at least partially removing said GaAs substrate after forming said gallium nitride compound layer.

2. The method of preparing a wafer for a light emitting device in accordance with claim **1**, wherein

said gallium nitride compound layer includes a GaN buffer layer and a GaN epitaxial layer,

said GaAs substrate being entirely removed.

3. The method of preparing a wafer for a light emitting device in accordance with claim **2**, wherein

the total thickness of said GaN buffer layer and said GaN epitaxial layer is at least 70 μm and not more than 400 μm,

said GaN buffer layer and said GaN epitaxial layer forming a GaN substrate.

4. The method of preparing a wafer for a light emitting device in accordance with claim **1**, wherein

said GaAs substrate is removed by at least one of machine work removal means, removal means through reactive ion etching employing chlorine gas, removal means through wet etching employing ammonia and hydrogen peroxide, and decomposition removal means in a high-temperature atmosphere of hydrogen chloride gas.

5. The method of preparing a wafer for a light emitting device in accordance with claim **1**, wherein

said gallium nitride compound layer includes a GaN buffer layer, a first GaN epitaxial layer, a first AlGaIn epitaxial layer, a luminescent layer containing InGaIn, a second AlGaIn epitaxial layer, and a second GaN epitaxial layer.

6. The method of preparing a wafer for a light emitting device in accordance with claim **5**, wherein

said gallium nitride compound layer has a thickness of at least 70 μm and not more than 200 μm,

said GaAs substrate being entirely removed.

7. The method of preparing a wafer for a light emitting device in accordance with claim **5**, wherein

said gallium nitride compound layer has a thickness of at least 70 μm and not more than 200 μm,

said GaAs substrate being partially removed.

8. The method of preparing a wafer for a light emitting device in accordance with claim **1**, wherein

said step of forming said gallium nitride compound layer includes the steps of:

forming a stripe pattern consisting of an insulating film on said GaAs substrate,

forming a buffer layer consisting of either GaN or AlN on said GaAs substrate and said stripe pattern after formation of said stripe pattern, and

forming a GaN epitaxial layer on said buffer layer,

said step of at least partially removing said GaAs substrate including a step of entirely removing said GaAs substrate.

9. The method of preparing a wafer for a light emitting device in accordance with claim **8**, wherein

said insulating film is prepared from either silicon dioxide or silicon nitride.

10. The method of preparing a wafer for a light emitting device in accordance with claim **8**, wherein

said insulating film has a width of at least 3 μm and not more than 20 μm, and a thickness of at least 0.05 μm and not more than 0.5 μm.