

A. B. GLOVER & D. M. CHURCH.  
Paper-Bag Machine.

No. 164,162.

Patented June 8, 1875.

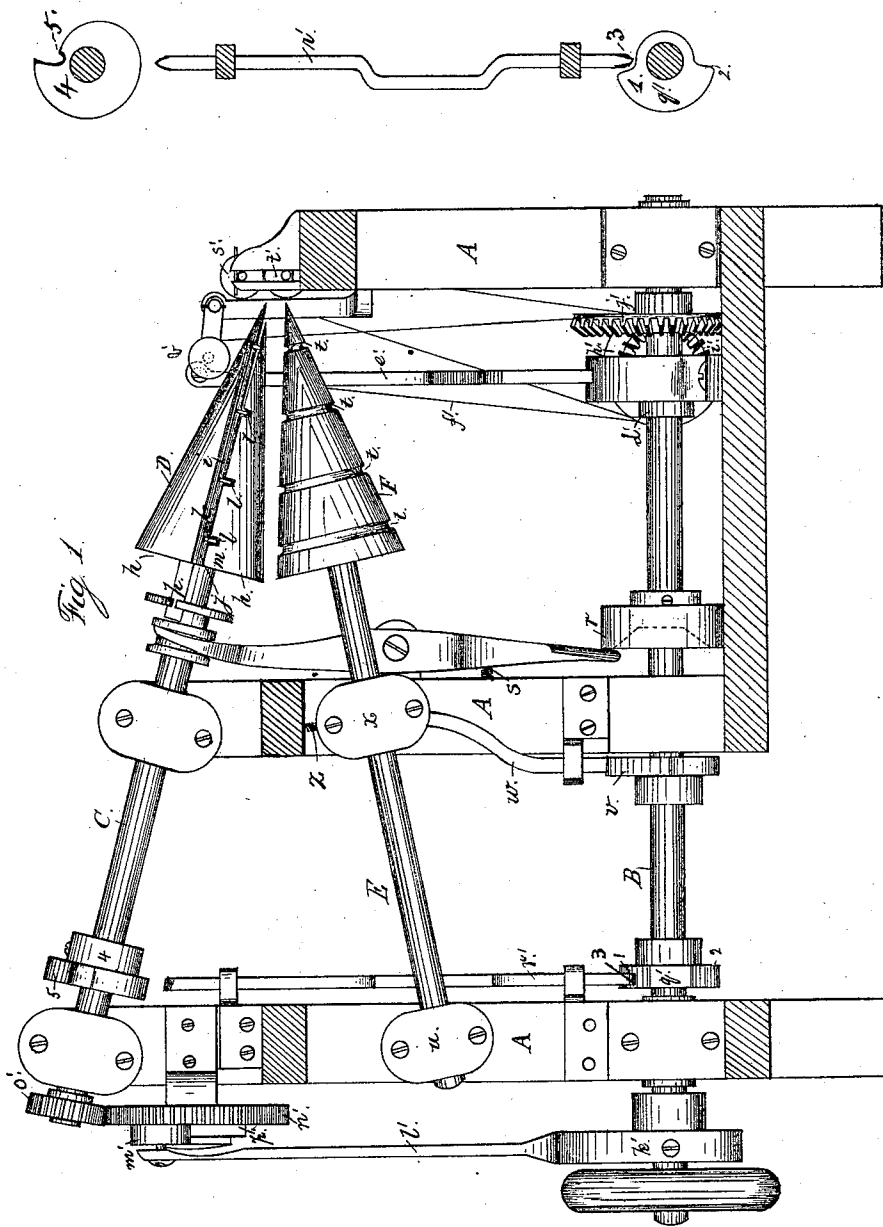

Fig. 1.

Witnesses;  
 Geo. J. Smallwood jr.  
 John Robey jr.

Inventors;  
 Almon B. Glover,  
 Dwight M. Church,  
 by John J. Halsted  
 atty

**A. B. GLOVER & D. M. CHURCH.**  
**Paper-Bag Machine.**

No. 164,162.

Patented June 8, 1875.

*Fig. 2.*

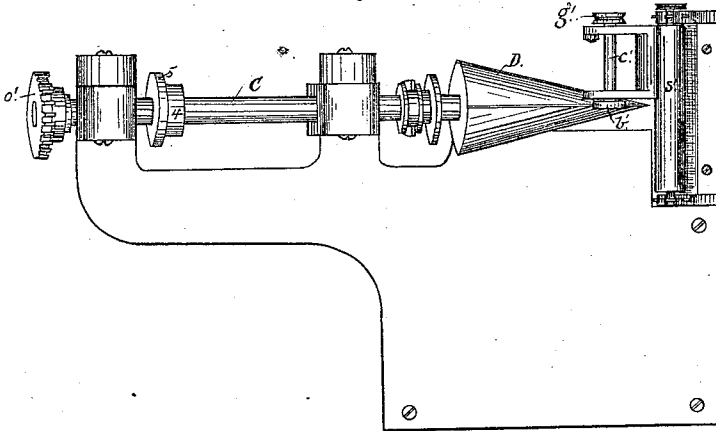

*Fig. 3.*

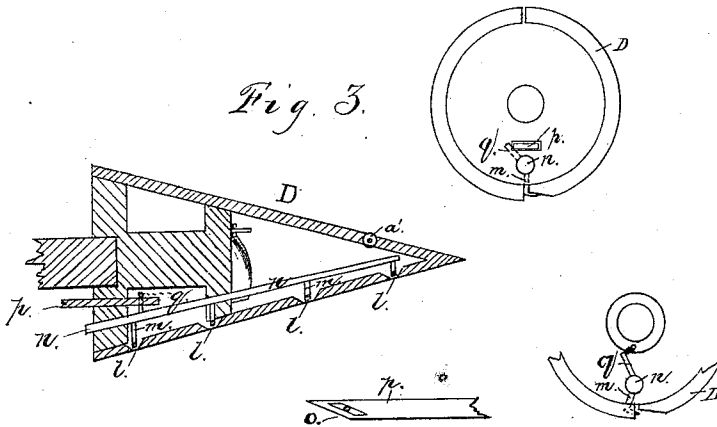

Witnesses.

*Geo. T. Smallwood Jr.*  
*John Robey Jr.*

Inventors.

*Almon B. Glover*  
*Dwight M. Church*  
*by John J. Halsted*  
*Atty.*

# UNITED STATES PATENT OFFICE.

ALMON B. GLOVER AND DWIGHT M. CHURCH, OF DERBY, CONNECTICUT.

## IMPROVEMENT IN PAPER-BAG MACHINES.

Specification forming part of Letters Patent No. **164,162**, dated June 8, 1875; application filed March 19, 1875.

*To all whom it may concern:*

Be it known that we, ALMON B. GLOVER and DWIGHT M. CHURCH, both of Derby, in the State of Connecticut, have invented certain Improvements in Paper-Bag Machines; and we do hereby declare that the following, taken in connection with the drawings which accompany and form part of this specification, is a description of our invention sufficient to enable those skilled in the art to practice it.

Our invention relates to the construction of machines adapted for making paper-bags of a conical form, or what are more commonly known as cornucopias; and it consists in constructing the hollow cone over which the paper is laid and formed into a bag with fingers for taking hold of and pulling the paper forward and wrapping it around the cone; in securing and operating these fingers inside the hollow cone, their clamping-tips, however, acting on the paper outside this cone; in constructing the under auxiliary cone or equivalent device with depressions or grooves adapted to receive these finger-tips, so that they may lie beneath its surface while the lower cone is holding the paper in contact with the upper one; in providing the lower cone, roller, or other device with means for causing it automatically to rise and hold the paper properly against the upper cone while the bag is being formed, and automatically to descend after the bag is formed to leave it free to be discharged; in providing the upper or hollow former-cone with discharging-rolls near its tip, one within and one without the cone, and intermittently brought into action as each bag is formed to grasp the paper and discharge the bag from the cone-former; in means for rotating the former a little beyond a full revolution for the purpose of rolling down the lapped and pasted seam, and then returning the former sufficiently to permit the taking off of the finished bag, and to bring the clips or fingers into position to take and grasp the paper-blank for another bag; in the employment, if desired, in connection with the forming-roll and its discharging-rolls, of a pair of calender or pressing rollers, operating to roll down the seam and fold the bag flat and suitable for packing; and in other details herein-after set forth.

In the drawings, Figure 1 is a side elevation of a machine embodying my invention; Fig. 2, a plan, showing the table and the mechanism above it; and Fig. 3 a section and details of the upper cone.

A is a suitable frame for supporting the mechanism; B, the main or driving shaft; C, the shaft of the hollow forming-cone D, and E the shaft of the lower cone F. The cone D, which serves to seize and wind upon itself the paper fed in from the table G, is hollow and composed of two or three sections, *h h*, at one of the junctions *i* of which is a longitudinal opening, *j*, having a bevel, *k*, and through notches *l l l* at this opening project the curved tips of fingers *m*, operating to seize, clip, and hold the edge of the sheet of paper against the bevel. These fingers are fixed to a rocking shaft, *n*, placed within the cone, and having its bearings in its ends, this shaft being rocked at proper intervals to cause the fingers to grasp the paper by means of the inclined end *o* or an inclined slot of a slide, *p*, acting upon a short arm, *q*, projecting laterally from the rocking shaft, the slide being actuated at each revolution of the cone-shaft C by means of a cam, *r*, thereon, a retracting-spring, *s*, within the cone, serving to return the slide to its normal position. The lower cone is provided with annular grooves *t t t*, adapted to receive the tips of the fingers while they are holding the paper and forming the cornucopia, and thus permitting them to lie beneath its surface, so that they offer no impediment to the proper holding of the paper in contact with both cones. The lower cone needs to be capable of moving slightly away from the upper one, when the formed cornucopia is drawn off the upper one, and therefore its shaft E is hung in a pivoted bearing, *u*, on the frame, and is arranged to be lifted at its free end at the proper period by means of a cam, *v*, on the main shaft, acting upon a rod, *w*, to raise a shifting bearing-block, *x*, supported on a bolt arranged to rise and fall in a slot in the frame, a spring, *z*, assisting to return the block to its place.

A small roller, *a'*, is arranged in a cavity near the tip of the upper cone, and having its surface about flush with the surface of the cone, and its axis transverse of the cone. A

fellow roller, *b'*, on a swinging arm, *c'*, is caused, by means of a cam, *d'*, on the main shaft B, and a lifting slide-rod, *e'*, to move downward at the proper period to press the paper against roll *a'*, and the roller *b'* being caused to revolve, by means of the cord or belt *f'*, which connects the pulley *g'* with the pulley *h'*, provided with a bevel-gear, *i'*, driven by gear *j'*, on the main shaft, the effect is to pull off the cornucopia endwise from the smaller end of the cone. The length of the cord *f'*, and its slight elasticity, permit this slight lifting.

It is necessary that the cone D should make more than a complete revolution in making each cornucopia, in order to lap the edge which has been previously pasted to form the closed seam; and it is also necessary that after the cornucopia has been formed, or formed and discharged, this cone should make a partial return revolution sufficiently to leave it in the position ready to take a new sheet with its fingers. In other words, it should return as far as it went beyond a full revolution, in order to lap the paper. To secure these movements automatically, and at the desired periods, I have devised the following mechanism: On the rear of the main shaft is an eccentric, *k'*, on which is hung the eccentric-rod *l'*, the upper end of which is pivoted to an oscillating block, *m'*, concentrically placed on the same center with the large gear-wheel *n'*, which is mounted on a fixed stud on the frame, and free to turn, as occasion demands, in either direction, the teeth of this wheel engaging with the small gear *o'*, through which the shaft of the upper cone derives its motion. The block *m'* is so connected to the eccentric-rod that the throw of the latter never causes it to make a complete turn upon its axis; and it is provided with a spring-pawl, *p'*, whose duty it is, at the time when the upper cone D is to roll the paper, to engage with one of the few teeth of a ratchet, whereby the gear *n'* is revolved in one direction only. This pawl, however, when the upper end of the eccentric has completed its sweep, leaves or ceases its forward motion just after the cone has completed its full movement—that is, when it has made a little more than a full revolution, in order to lap the pasted edges of the paper. It is next necessary that the cone should reverse a short distance equal to the lap or seam of the paper, and thus be ready to take up with its fingers the sheet of paper to be formed into another bag; and this is effected as follows, but not through the agency either of the main shaft or of the gear *n'*, or of the pawl *p'*: A cam, *q'*, on the main shaft serves to lift a vertically-movable rod, *r'*, supported (like the other slide-rods of the machine) in suitable guides, the lifting portion 1 of this cam having a gently-curved incline, 2, and the lower end of the rod having also a curvature, 3, the upper end of this slide-rod, when it rises, coming into action upon the peculiar cam 4 and its notch 5 on the upper roller-shaft.

When the bag or cornucopia has been pasted,

and the upper roller is ready to make its short return movement named above, the rod *r'* comes into action by means of the peculiar form of the curvatures 2 3, and the curved or rounded bevel on the upper end of the rod, and the curved part 5, or abrupt tooth, on the cam 4, the final terminal upward movement of the rod acting by means of the bevel end of the rod and the curve 5 to force back the cam 4, and thus to reverse for a short period and distance the movement of the shaft and the upper roller. In this peculiar reverse movement of this upper shaft its gear *o'*, which is in constant engagement with the gear-wheel *n'*, causes the latter to reverse also; but this does not cause any reversing of the main shaft, or at all affect it, because when the gear *n'* is thus slightly reversed it is in fact an idle wheel, and the pawl *p'* at that juncture is moved freely on the cam, and the continuous movement of the main shaft is at that period also inoperative to drive the upper shaft, inasmuch as the gear *n'* is not then actuated by the pawl.

The notch 5, when the rod *r'* has thus reversed the movements, serves, in connection with the cam on the lower shaft, to lock to place the rod, and, consequently, the upper shaft, for the time being, and thus prevent any turning until the descent of the rod releases it from this detaining-notch, after which the gear *n'* is again in condition to be acted upon by its driving-pawl, and to revolve the forming-roller, it being understood that, in the mean time, the discharging-rollers *a' b'* have been brought into action, to discharge from the cone the formed cornucopia or bag. The roller *a'* may be roughened on its periphery if desired.

Two calender or flattening rollers, *s' t'*, may be employed or not, as desired, to receive the bag as it is discharged from the cone, and thus deliver it in a proper compact condition for packing, flat and in quantities. It will be seen that they compress the bag, while the rollers *a' b'* merely grasp the one thickness of paper and discharge the bag in its round or open form. The rollers *s' t'* may be removed or dispensed with altogether, or secured on a frame to be swung into or out of action, as needed; or the upper roller *s'* may be arranged to swing out of action, or to be slightly raised, so as not to pinch, and compress, and fold the bag. These rollers are shown as driven positively by means of cord and pulley, the cord being driven from the same grooved wheel which imparts motion to the small roller *b'*.

The pieces of paper of which each cornucopia is made are oblong in form, so that there is not a particle of waste of material, nor a particle of unused or useless paper doubled upon itself merely to attain the desired final form, as in making most bags, the only doubled part being the necessary lapped edges. The strip from which the blank is cut is, therefore, simply a strip of ribbon having parallel sides,

and the blanks are each cut a little longer than the width of the strip, one edge only of the longer sides being pasted.

We do not show any devices either for pasting or cutting, as they form no part of our present invention, and they may be of any known kind.

We claim—

1. The forming-cone, made hollow, and provided with the internal automatically-operated nipper-shaft *n*, set at an inclination to the cone-shaft and parallel with the peripheral surface of the cone, the cone-shaft terminating within the cone, substantially as and for the purpose set forth.

2. In combination with the hollow cone, and with the nipper-shaft within the same, set at an incline to its axis, the slide *p*, automatically operating to actuate the nippers, substantially as shown and described.

3. The gearless shaft *E*, on which is the lower cone, having peripheral grooves, in combination with the pivoted bearing *u*, cam *v*, lifting-rod *w*, shifting-block *x*, and reacting-spring *z*, as and for the purposes set forth.

4. In combination with the upper hollow

forming-cone, the discharging-rolls *a' b'*, the one journaled in the cone near its tip, and the other arranged to be automatically and intermittently operated to engage and disengage with it, and both serving to loosen the cornucopia from its cone, and then to pull it endwise therefrom.

5. In combination with the upper cone or former mechanism, substantially as, and operating as described, to rotate the former beyond a full revolution, and to reverse the movement to the point of such full revolution, and bring the clips into position to grasp the paper for another bag.

6. The combination, with the main shaft, its eccentric and eccentric rod, and with the shaft *C* and its gear *o'*, of the gear *n'*, toothed plate or ratchet and pawl, the gear *n'* at times being the driver of *o'*, and at other times being or turned back by *o'*, while the main shaft continues its revolution in one direction only.

ALMON B. GLOVER.

DWIGHT M. CHURCH.

Witnesses:

GEORGE H. PECK,

SILAS CHAPIN.