



(51) International Patent Classification:

B41J 25/308 (2006.01) *B41J 25/34* (2006.01)
B41J 25/304 (2006.01) *B41J 2/165* (2006.01)

(21) International Application Number:

PCT/EP2014/079155

(22) International Filing Date:

23 December 2014 (23.12.2014)

(25) Filing Language:

English

(26) Publication Language:

English

(71) Applicant: **JOLYAN HOLDING SA** [LU/LU]; 4, rue Albert Broschette, L-1246 Luxembourg (LU).

(72) Inventor: **GEARING-THOMAS, Nigel Francis**; 4, rue Albert Borschette, L-1246 Luxembourg (LU).

(74) Agent: **THIBAUD, Jean-Baptiste**; Loyer & Abello, 9, rue Anatole de la Forge, F-75017 Paris (FR).

(81) Designated States (unless otherwise indicated, for every kind of national protection available): AE, AG, AL, AM, AO, AT, AU, AZ, BA, BB, BG, BH, BN, BR, BW, BY,

BZ, CA, CH, CL, CN, CO, CR, CU, CZ, DE, DK, DM, DO, DZ, EC, EE, EG, ES, FI, GB, GD, GE, GH, GM, GT, HN, HR, HU, ID, IL, IN, IR, IS, JP, KE, KG, KN, KP, KR, KZ, LA, LC, LK, LR, LS, LU, LY, MA, MD, ME, MG, MK, MN, MW, MX, MY, MZ, NA, NG, NI, NO, NZ, OM, PA, PE, PG, PH, PL, PT, QA, RO, RS, RU, RW, SA, SC, SD, SE, SG, SK, SL, SM, ST, SV, SY, TH, TJ, TM, TN, TR, TT, TZ, UA, UG, US, UZ, VC, VN, ZA, ZM, ZW.

(84) Designated States (unless otherwise indicated, for every kind of regional protection available): ARIPO (BW, GH, GM, KE, LR, LS, MW, MZ, NA, RW, SD, SL, ST, SZ, TZ, UG, ZM, ZW), Eurasian (AM, AZ, BY, KG, KZ, RU, TJ, TM), European (AL, AT, BE, BG, CH, CY, CZ, DE, DK, EE, ES, FI, FR, GB, GR, HR, HU, IE, IS, IT, LT, LU, LV, MC, MK, MT, NL, NO, PL, PT, RO, RS, SE, SI, SK, SM, TR), OAPI (BF, BJ, CF, CG, CI, CM, GA, GN, GQ, GW, KM, ML, MR, NE, SN, TD, TG).

Published:

— with international search report (Art. 21(3))

(54) Title: DIGITAL DECORATING MACHINE

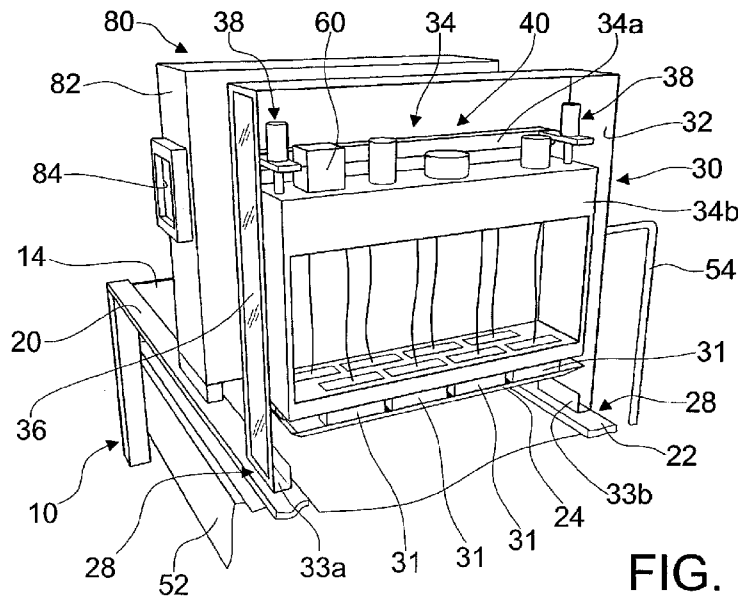

FIG. 2

(57) Abstract: A digital decorating machine has a base (10), at least one conveyor for transporting the products to be decorated along a feed direction, at least one decoration module (30), associated with the base (10) and positioned above said conveyor; the module (30) comprises a containment box-like element (32) and, inside the latter, a support (34) for printing heads (31), the support (34) is vertically movable, with respect to the box-like element (32), so as to selectively move at least the printing heads (31) between a first upper inactive position and a second lower operative position, in which said heads (31) are positioned at the correct delivery distance with respect to the surface of the products.

WO 2016/102000 A1

“DIGITAL DECORATING MACHINE”

TECHNICAL FIELD OF THE INVENTION

The present invention relates to a digital decorating machine.

5 More in particular, the present invention relates to a digital decorating machine for products such as ceramic tiles, ceramic materials in general, as well as wood, fabric, and other similar materials.

In the following discussion specific reference will be made to ceramic tiles, but it must be considered that the present invention can be equally applied for the digital
10 decoration of wood or fabric and other similar materials.

STATE OF THE PRIOR ART

In the field of the production of ceramic tiles and the like decoration lines are normally employed that apply inks and/or enamels to the surface of the ceramic support, adapted to create both a certain aesthetic and decorative effect and a
15 functional result of protection and coverage of the support itself.

Currently, digital decorating machines are increasingly used in the field, which apply ink and/or enamel on the ceramic support by means of heads that deliver a jet actuated by piezoelectric controlled nozzles or nozzles of other type whose
20 actuation and adjustment are driven for the purposes of the decorative process in a digital manner.

The use of digital decorating machines is now widely preferred mainly because they allow obtaining a very high graphic resolution in the application of the decorative and/or protective product on the ceramic support, and on other supports
as well.

25 Indeed, the current technologies allow simulating, with truly surprising results, natural materials such as wood, marble, granite, or the like.

The digital decorating machines of the aforementioned type provide for a printing area of the ceramic supports comprising a plurality of adjacent modules; each of the above modules is provided with respective heads for delivering ink or enamel
30 on the surface of the supports themselves.

Each printing module is equipped with means for supplying a single type of ink or enamel to said delivery heads; for example, each module is typically suitable for delivering one ink of a certain color.

5 The digital decorating machines currently present on the market are not free from drawbacks.

In fact it is observed that the modern machines for digital decoration are conceived for operating not only in the classic quadrichromy mode – which would require, indeed, the presence of four corresponding printing modules – but they can also operate by applying inks or other fluids on the products, which were
10 already previously prepared with the desired final colors, that can obviously be quite numerous.

By way of example, in order to respond to specific production needs, the decorating machines according to the present invention can also comprise 12-16 adjacent printing modules.

15 In some production situations, that is in carrying out certain decoration works, among the numerous modules present on the machine, only some are actually employed simultaneously in the same work, and in some cases only one module may be working, that is the module corresponding to the desired color.

This means that all the modules that are not operative in a certain decoration work
20 have the respective heads still positioned in proximity to the surfaces of the products being decorated, that is at a distance of very few millimeters from the same.

In this condition, the non-operative heads are nevertheless exposed to degrading agents, such as high temperatures and suspended ink particles that can lead to the
25 rapid oxidation of the same or that can determine in any case malfunction conditions in the heads, which need to be remedied with consumption of resources and waste of time.

Therefore there is the need, in the field, to remedy such drawback.

OBJECTS OF THE INVENTION

30 The technical task of the present invention is therefore to improve the state of the

art.

Within such technical task, an object of the present invention is to provide a digital decorating machine that allows overcoming the previously lamented drawbacks.

Another object of the present invention is to obtain a digital decorating machine
5 that allows preserving the non-operative heads during a certain decoration work from degrading agents present in the printing area.

This task and these objects are attained by the digital decorating machine according to the enclosed claim 1.

The digital decorating machine according to the invention comprises a base, at least
10 one conveyor, adapted to transport the products to be decorated along a feed direction, and at least one decoration module, associated with the base and positioned above the conveyor.

The decoration module comprises respective heads provided with nozzles for
ejecting a fluid to be delivered on the surface of the products to be decorated, and a
15 box-like element inside which means for supplying the fluid to the aforesaid heads are provided.

According to the present invention, the decoration module houses a frame therein
comprising a first portion associated with the box-like element, and a second
portion with which at least the heads are integral; the second portion is movable,
20 with respect to the first portion, from a first upper inactive position to a second lower operative position, in which the heads are positioned at the correct dispensing distance with respect to the surface of the products.

In this manner, the heads, when they are in the upper inactive position, are preserved from the action of external degrading agents present in the printing area.

25 The dependent claims refer to preferred and advantageous embodiments of the invention.

BRIEF DESCRIPTION OF THE DRAWINGS.

The characteristics of the invention will be better understood by any man skilled in the art from the following description and the enclosed set of drawings, given as a
30 non-limiting example, in which:

- figure 1 is a front perspective view of a digital decorating machine according to the invention;
- figure 2 is a detailed perspective view of a module of the decorating machine, with some parts removed for greater clarity;
- 5 figure 3 is a detailed perspective view of the module of figure 2, in a different operative configuration and with some parts removed for greater clarity;
- figure 4 is a detailed perspective view of a module of the machine in still another operative configuration;
- figure 5 is a detailed perspective view of a module of the machine removed from
10 the base;
- figure 6 is a detailed rear perspective view of the machine according to the invention; and
- figure 7 is a detailed perspective view, with some parts removed for greater clarity, of a module of the machine according to another embodiment of the
15 invention.

EMBODIMENTS OF THE INVENTION

With reference to the enclosed figure 1, a digital decorating machine according to the present invention is indicated as a whole with 1.

The machine according to the invention is particularly, but not exclusively,
20 intended for the application of decorative and/or protective fluids, such as inks, enamels and the like on products such as ceramic tiles and the like.

However, as already mentioned above, the machine according to the invention is absolutely for general use and could also be employed for other types of ceramic and non-ceramic products, without any limitation.

25 Furthermore, it is specified that the decorating machine 1 according to the present invention is suitable for the application of fluids such as inks, enamels and the like on ceramic products in any state, that is for example green or fired.

In the following description, therefore, it is assumed that the products 2 to be decorated consist of ceramic tiles, of any form or shape, but one must take into
30 account that the present invention can be equally applied for the digital decoration

of parts made of wood, fabric and other similar materials.

The machine 1 according to the invention can be installed in the context of a complete decoration line for ceramic tiles, which is assumed to comprise for example other machines of the same type, or possibly also of other type.

5 The machine 1 comprises a base 10, which comprises, for example, a plurality of uprights 11, or legs, for supporting the machine 1.

The base 10 further comprises a conveyor for the products 2 to be decorated, indicated as a whole with 12.

10 The conveyor 12 is adapted to transport the products 2 to be decorated along a feed direction A.

In the illustrated embodiment, the conveyor 12 comprises a belt 14.

The belt 14 is developed along the feed direction A of the products 2.

The belt 14 is mounted on two rollers 16, 18, one of which is normally motorized and one of which is idle.

15 The rollers 16, 18 are rotatably supported by the base 10 of the machine 1 at two respective parallel rotation axes.

In the enclosed figures the rotatable support means of the rotation axes 16, 18 of the belt 14 are not illustrated for the sake of simplicity.

20 According to an aspect of the present invention, the base 10 of the machine 1 comprises support elements 20, 22.

The support elements 20, 22 are developed parallel to the feed direction A and the sides of the conveyor 12.

25 In one version of the invention, the support elements 20, 22 comprise longitudinal elements oriented parallel to the feed direction A and fixed for example to the top of the uprights 11.

The specific function of the support elements 20, 22 will be clearer in the following.

According to another aspect of the present invention, the machine 1 comprises at least one digital decoration module 30 for the products 2.

30 It is noted that in the context of the present description, as well as in the enclosed

claims, with the term “decoration”, referred in particular to the aforesaid at least one module 30, it is intended to indicate, in general, both the application, on the surface of the products 2, of decorative fluids in the strict sense, such as colored inks and the like, and the application of other products such as protective enamels, and still others, without any limitation to the objects of the present invention.

In other embodiments of the invention, of particular practical interest, the machine 1 comprises a plurality of modules 30, 30' adjacent to each other along the feed direction A of the products 2.

For example, in figure 1, the possibility of installing two adjacent modules 30, 30' along the feed direction A is shown.

It is however specified that the number of the modules 30, 30' provided in the machine could be any number, without any limitation.

The modules 30, 30' each comprise respective printing heads 31 provided with nozzles for ejecting a fluid – an ink, an enamel, etc. – to be delivered on the surface of the products 2 to be decorated.

Such heads 31 are visible, for example, in the figures 2, 3 and 4.

The printing heads 31 can be of any type and will not be further described in detail. Each of the modules 30, 30' comprises means 40 for supplying the fluid to said heads 31.

The supply means 40 of each of the modules 30, 30' are placed in communication with a respective tank 50 containing the fluid to be delivered.

A tank 50 is schematically illustrated in figure 6. The tank 50 of each module 30, 30' can be situated in any area of the machine 1.

For example, according to a particularly advantageous version from the bulk standpoint, the tank 50 can be housed inside a space 52 suitably provided for in the base 10, under the belt 14.

The transfer of the fluid from the tank 50 to the means 40 for supplying the fluid occurs, for example, through a conduit 54. Along the conduit 54, quick connection/disconnection means can be provided, possibly also for mutually and quickly exchanging the connections between the different modules 30, 30' and the

respective fluid tanks 50.

The means for supplying 40 the fluid to the heads 31, which do not constitute an object of the present invention, are of a type suitable, in the context of the same module 30, 30', for generating an autonomous fluid circulation during the
5 operation of the machine 1: such autonomous circulation allows keeping the fluid under optimal conditions also during times of inactivity of the heads 31.

For example, for this purpose the means 40 for supplying fluid of each module 30, 30' can comprise multiple tanks inserted in series in a circuit through which the fluid is made to circulate.

10 Each module 30, 30' also comprises a respective local control unit 60 of the operation of the printing heads 31, adapted to specifically manage the modes of fluid supply by the same.

The local control unit 60 can consist of, for example, an electronic board, or similar control elements.

15 Each of the modules 30, 30' comprises a respective containment box-like element 32.

The means 40 for supplying fluid, the local control unit 60 as well as all the components necessary for the operation of the module itself are completely housed inside the box-like element 32.

20 An important characteristic of the present invention is that each module 30, 30' comprises and houses therein support means 34 for at least the printing heads 31.

The support means 34 with the printing heads 31 are vertically movable, with respect to the containment box-like element 32, by means of translation means 38 that allow selectively moving at least the printing heads 31 between a first upper
25 inactive position (figure 2) and a second lower operative position (figure 3).

Under normal operation conditions of the module 30, 30', the support means 34 are in the second lower operative position, so that the printing heads 31 are positioned at the correct distance for printing on the surface of the products 2.

30 When the same module 30, 30' is not used, instead, the support means 34, carrying the printing heads 31, can be translated in the first upper inactive position, where

the printing heads 31 are sufficiently spaced from the surface of the products 2.

According to a version of the present invention, the support means 34 comprise a first portion 34a associated with the box-like element 32 and a second portion 34b movable according to the modes better described in the following.

5 The second movable portion 34b features at its bottom a base to which the printing heads 31 are associated.

The supply means 40, the local control unit 60 and all the other components necessary for the operation of the module 30, 30' can also be attached to the second movable portion 34b.

10 In other words, the movable portion 34b can only support the printing heads 31, or the supply means 40, the local control unit 60 and all the other components necessary for the operation of the module 30, 30'.

According to a version of the present invention, the first portion comprises a fixed frame 34a attached to the box-like element 32 and the second movable portion
15 comprises a frame 34b that can be moved with respect to the fixed frame 34a by means of the translation means 38.

The translation means 38 can be of manual or motorized type and comprise, for example, a first linear actuator 38a and a second linear actuator 38b supported, with vertical translation axis, by the first portion 34a, and associated with the second
20 portion 34b.

The first linear actuator 38a and the second linear actuator 38b are associated with the opposite ends of the first portion 34a.

In the embodiment of the invention illustrated in the figures, the first linear actuator 38a and the second linear actuator 38b comprise electric motors, for example
25 stepper electric motors.

The output axes of the aforesaid electric motors 38a, 38b are respectively connected with a first screw 39a and a second screw 39b, engaged in turn in respective nuts provided in the upper area of the second portion 34b.

The module 30, 30' can also comprise a position sensor (not illustrated), for
30 example a linear encoder, to directly verify the actual vertical position of the

second movable portion 34b with respect to the fixed portion 34a.

Under normal operating conditions of the module 30, 30', the second portion 34b is in the second lower operative position, so that the heads 31 are positioned at the correct distance with respect to the surface of the products 2.

5 When the same module 30, 30' is not used instead, the respective second portion 34b, carrying the printing heads 31, can be translated into the first upper inactive position, where the heads 31 themselves are sufficiently spaced from the surface of the products 2.

This measure has the purpose of protecting the heads 31 of that specific module 30, 10 30', that are temporarily unused, from thermal radiations possibly generated by the passing products 2, and/or by the fluid particles emitted by the other heads 31 of the machine that are suspended in the printing area.

In this manner the heads 31, suitably preserved, can have a longer duration, and/or the maintenance or cleaning interventions are consequently cheaper and easier.

15 According to another aspect of the present invention, each module 30, 30' comprises a respective protection element 24 of the heads 31.

More in detail, the protection element 24 – schematically illustrated in figure 2 – has the function of shielding the lower delivery surface of the heads 31 from agents that could compromise its proper functionality, such as for example, as mentioned 20 above, heat, suspended fluid particles or still others.

The protection element 24 is for example shaped as a tray, and can be removably associated with the lower part of the second portion 34b so as to completely cover the lower surface of the heads 31.

The protection element 24 can also collect small amounts of ink, enamel, etc..

25 In fact, in the unused heads 31, it is possible to control the delivery of the ink, enamel, and the like, at predetermined time intervals, from the nozzles, this preventing clogging of the nozzles themselves – which can occur instead when the heads are not used for long periods of time – thereby ensuring the correct operation of the printing heads themselves, when that printing module will be used again.

30 The first portion 34a of the frame 34 is slidably associated with the respective box-

like element 32 according to a substantially horizontal direction.

More in detail, as illustrated schematically in figure 4, the first portion 34a is slidably associated with the box-like element 32 by interposition of at least one guide 26, of any type.

- 5 For simplicity, only one guide 26 is illustrated in figure 4; obviously any number of guides 26 can be provided for, to ensure the correct and effective sliding of the first portion 34a with respect to the box-like element 32.

The frame 34 can thus be completely translated frontally and horizontally outside of the box-like element 32, and possibly also completely extracted and removed,
10 for the sake of maintenance, replacement, or others.

An easy lateral access to the frame 34 by operators is therefore ensured, the operators thus being able to carry out any maintenance intervention or the like.

For this purpose, the box-like element 32 frontally defines an opening 35 closed by a respective door 36.

- 15 The door 36 can be for example of concealed type, that is recessed inside the box-like element 32 to allow access to the opening 35 and at the same time to limit bulk.

For example, as shown schematically in figure 4, the door 36 can be associated with particular hinges or rotation mechanisms allowing the positioning thereof
20 under the upper wall of the box-like element 32, in a minimal bulk position.

According to yet another aspect of the present invention, the at least one module 30, 30' of the machine 1 is associated with the support elements 20, 22 in a removable manner.

- 25 Due to this solution, each module 30, 30' is virtually an independent operative unit, complete with all the necessary components.

Therefore, if needed it is possible to completely remove a certain module 30, 30' from the support elements 20, 22, for example in order to mount them on another machine.

- 30 In consideration of the fact that each module 30, 30' normally operates with a single fluid— for example an ink of a certain color— it is clear that this solution

allows each machine 1 present in the decoration line to be equipped with the modules 30, 30' of the desired colors, in an absolutely free and highly versatile manner.

In other words, if multiple digital decorating machines 1 according to the invention are present along the decoration line, the user can rapidly and easily exchange with each other the modules 30, 30' that, in the context of a certain decoration work, are associated with certain machines 1, to obtain different color combinations suitable for carrying out a different decoration work.

The same operation can obviously be performed between machines 1 belonging to distinct decoration lines.

The machines 1 thus become completely universal and completely interchangeable, as well as being able to be prepared in a different way from time to time in relation to the specific work to be performed.

For this purpose, the machine 1 comprises removable coupling means 28 provided between the ends 33a, 33b of the base of the box-like element 32 of each module 30, 30' and at least one of the support elements 20, 22.

More in detail, the removable coupling means comprise first elements 28a associated with the ends 33a, 33b of the base of the box-like element 32, and second elements 28b, couplable to the first elements 28a, provided in designated coupling areas 29 of the support elements 20, 22.

According to a version of the present invention of particular practical interest, the removable coupling means 28 are of self-centering type.

More in detail, in this embodiment the first elements 28a consist of conical appendages that project from the ends 33a,33b of the base of the box-like element 32, while the second elements 28b consist of corresponding conical seats provided for in designated coupling areas 29 of the support elements 20,22.

The conical coupling between the first elements 28a and the second elements 28b ensures the quick and easy centering of the box-like element 32 at the coupling zones 29; the taper of the conical coupling is chosen so as to always allow a quick and rapid disassembly.

Auxiliary locking means of the box-like element 32 on the support elements 20, 22 are also provided.

The base 33 of the box-like element 32 therefore has a substantially bridge-like conformation, which allows positioning the heads 31 at the correct height with respect to the surface of the products 2 passing freely below the same, and at the same time allows the box-like element 32 itself to be coupled to the base 10 of the machine 1 in a practical and precise manner, without it being necessary to use other support structures or frames of the module 30, 30' above the conveyor 12.

Moreover, the removal of the module 30, 30', for example for replacement or installation on another machine, is particularly quick and easy.

According to another aspect of the invention, the machine 1 comprises a central processing unit 80.

The central processing unit 80 is adapted, in particular, to manage the coordinated operation of the at least one module 30, 30' during a certain decoration work.

The central processing unit 80 is associated with the support elements 20, 22 of the base 10 for example by removable coupling means 28 of the type previously described, or by other equivalent means.

The central processing unit 80 comprises a respective box-like support 82, for example having a structure similar to that of the box-like element 32 of the module 30, 30'.

Inside the box-like support 82, a machine control group 1, for example a PLC (*programmable logic controller*), or a microprocessor, or another processor equivalent thereto is installed; the electric power supply of the machine 1, and/or any other component necessary to manage its operation can also be housed inside the box-like support 82.

Outside the box-like support 82, a user interface 84 can also be provided, operatively connected to the machine control group 1, for setting and controlling decoration programs and/or operation parameters of the same.

The aforesaid decoration programs can also be imported from a memory unit external to the central processing unit 80.

As illustrated schematically in the rear view of figure 6, the machine 1 comprises electric connectors 27 that allow connecting the central processing unit 80 to the at least one module 30, 30', both as regards the electric power and the control logic.

The electrical connectors 27, both for their conformation and for their positioning, must allow a quick and easy electric attachment or detachment of the at least one module 30, 30', to allow the easy removal/replacement thereof.

Alternatively, between the central processing unit 80 and the at least one module 30, 30' wireless connection means may be provided, mainly with regard to control aspects.

The central processing unit 80 can possibly be permanently associated with the base 10 of a certain machine 1.

As already explained above, the at least one module 30, 30' of the machine 1 can be quickly and easily replaced, at all times, with other modules 30, for example also coming from other machines of the same type, since they constitute independent operative units.

The modules 30, 30' of the machine are therefore fully functionally interchangeable elements, i.e. the aforesaid modules 30, 30' can be installed on various machines of the same type and in accordance with the present invention.

The operation of the machine 1 according to the invention is, in the light of that described above, completely intuitive.

After having installed on the support elements 20, 22 one or more modules 30, 30' necessary to carry out a certain decoration work – for example modules 30, 30' suitable for delivering inks of certain colors – the second portion 34b of the frame 34 of the module 30, or of each module 30, 30' if present in higher number, is brought into the second lower operative position, in which the heads 31 are at the correct distance from the surface of the products 2 to be decorated.

The control group of the machine 1 can start the decoration work, in which the module 30 or each module 30, 30' delivers its fluid, in close coordination with the other modules if present, in the manner prescribed by the specific preset decoration operational program.

It should be noted that the modules 30, 30' present in the machine 1 can be removed to be installed, for example, on another machine 1 of the same type in which that particular type of ink or enamel is required.

As mentioned, more in general, all the modules 30, 30' of a same machine 1 can be replaced with others at the end of a certain decoration work; moreover the modules
5 30, 30' of multiple machines 1 of the same type can be quickly and smoothly exchanged with each other, so as to prepare the machines for a subsequent work.

The technical advantages of the proposed solution are clear.

First of all, the heads 31 of the modules 30, 30' that are not used in a certain
10 decoration work are lifted with respect to the surface to be decorated of the products 2, and the delivery surfaces thereof are shielded by the protection element 24: the heads 31 are suitably preserved from degrading agents present in the printing area, and therefore have a longer duration and require less maintenance.

Moreover, the machine 1 according to the invention, being completely modular,
15 can be realized in only one version and no longer in different versions related to the number of the modules 30, 30' provided.

For example, it is possible to realize support elements 20, 22 of size sufficient to house the maximum number of modules 30, 30'.

Alternatively, for bulk reasons, it is possible to provide support elements 20,22 of
20 different size related to the number of modules 30, 30' to be installed; also the base 10 can be realized specifically for the number of modules 30, 30' to be installed, thereby obtaining a more compact machine 1.

The support elements 20, 22 could be the only specific components for the type of machine in relation to the number of modules 30, 30' to be installed; the modules
25 30, 30' are instead, as mentioned, of general use, as are the base 10 and the central processing unit 80.

Even if one wishes to adopt the latter solution, logistics and warehouse costs are still drastically reduced compared to the current situation where different machine versions are present, each with its own specific components.

30 Where multiple machines 1 according to the invention are installed along the same

decoration line, it is no longer necessary to move or replace machines in relation to the type of work to be carried out: the bases 10 of the machines 1, possibly together with the respective central processing units 80, can be installed even in a permanent manner along the line, since such parts do not have to be removed when the work
5 to be carried out is changed or when other operating conditions are changed.

Another important advantage achieved by the machine 1 according to the invention is the considerable reduction of bulk mainly in the transverse direction with respect to the feed direction A of the products.

In fact, compared with the machines of known type, the electrical cabinet, which is
10 normally very bulky, was completely removed.

In figure 7 another version of the present invention is illustrated.

This embodiment differs from the previous one in that the translation means 38
comprise a single first linear actuator 38a supported, with vertical translation axis,
by the first portion 34a of the frame 34, and associated with the second portion 34b
15 of the same.

For example, the first linear actuator 38a can be constituted by an electric motor whose output axis is connected to a respective single first screw 39a; the first screw 39a is in turn engaged in a respective nut provided in the upper central area of the second portion 34b of the frame 34.

20 It is therefore a structurally simplified version compared to the previous version.

It has thus been shown how the invention achieves the intended objects.

The present invention has been described according to preferred embodiments, but equivalent variants can be conceived without departing from the scope of protection offered by the following claims.

25

CLAIMS

1. Digital decorating machine (1) for decorating products (2), comprising a base (10), at least one conveyor (12), adapted to transport the products (2) to be decorated along a feed direction (A), at least one decoration module (30, 30'), associated with said base (10) and positioned above said conveyor (12), said at least one module (30, 30') comprising respective printing heads (31) provided with nozzles for ejecting a fluid to be delivered on the surface of the products (2) to be decorated, and a box-like element (32) inside which means (40) for supplying fluid to said heads (31) are provided, each module (30, 30') comprising and housing therein support means (34) for at least said heads (31), **characterized in that** said support means (34) are vertically movable, with respect to the containment box-like element (32), so as to selectively move at least the printing heads (31) between a first upper inactive position and a second lower operative position, in which said heads (31) are positioned at the correct delivery distance with respect to the surface of the products (2).
2. Machine according to claim 1, wherein said module (30, 30') comprises translation means (38) of manual or motorized type for the vertical movement of said support means (34) for at least said heads (31).
3. Machine according to claim 1 or 2, wherein said support means (34) comprise a first fixed portion (34a) associated with said box-like element (32), and a second movable portion (34b) with which at least said heads (31) are integral.
4. Machine according to claim 2 or 3, wherein said translation means (38) comprise at least one first linear actuator (38a) supported, with vertical translation axis, by said first portion (34a), and associated with said second portion (34b).
5. Machine according to claim 2 or 3, wherein said translation means (38) comprise a first linear actuator (38a) and a second linear actuator (38b) supported, with respective vertical translation axes, by the opposite ends of said first portion (34a), and associated with said second portion (34b).
6. Machine according to claim 4, wherein said first linear actuator (38a) comprises an electric motor, the output axis thereof being connected to a respective

first screw (39a), in turn engaged in a respective nut provided in the upper area of said second portion (34b).

7. Machine according to claim 5, wherein said first linear actuator (38a) and said second linear actuator (38b) comprise respective electric motors, the output
5 axes thereof being respectively connected to a first screw (39a) and a second screw (39b), in turn engaged in respective nuts provided in the upper area of said second portion (34b).

8. Machine according to any one of claims 3 to 7, wherein said at least one
10 module (30, 30') comprises a position sensor, for example a linear encoder, to verify directly the actual vertical position of the second movable portion (34b) with respect to the fixed portion (34a).

9. Machine according to any one of the preceding claims, wherein said first
15 portion (34a) is slidably associated in a substantially horizontal direction to said box-like element (32), so as to be able to be partially or completely translated outside of said box-like element (32) through a suitable front opening (35).

10. Machine according to any one of the preceding claims, wherein said base
(10) comprises at least two support elements (20, 22), arranged on either side of said conveyor (12), to which respective ends (33a, 33b) of the base of said box-like
20 element (32) can be coupled, so as to realize a substantially bridge-like structure under which the products (2) to be decorated are intended to pass.

11. Machine according to claim 10, comprising removable coupling means (28)
provided between said ends (33a, 33b) of the base of said box-like element (32)
and at least one of said support elements (20, 22).

12. Machine according to claim 11, wherein said removable coupling means
25 (28) comprise first elements (28a) associated with said ends (33a, 33b) of the base of said box-like element (32), and second elements (28b), couplable to said first elements (28a), provided in suitable coupling areas (29) of said support elements (20, 22).

13. Machine according to claim 11 or 12, wherein said removable coupling
30 means (28) are of self-centering type.

14. Machine according to claim 13, wherein said first elements (28a) comprise conical appendages projecting from said ends (33a,33b) of the base of said box-like element (32), said second elements (28b) comprising corresponding conical seats provided in suitable coupling areas (29) of said support elements (20, 22).
- 5 15. Machine according to any one of the preceding claims, wherein said support elements (20, 22) comprise, or consist of, longitudinal elements, integral with said base (10) and oriented parallel to said feed direction (A).
16. Machine according to any one of the preceding claims, comprising at least one central processing unit (80) operatively connectable to said at least one module
10 (30, 30'), said processing unit (80) being associated with said support elements (20, 22) by removable coupling means (28).
17. Machine according to any one of the preceding claims, wherein said means (40) for supplying said at least one module (30, 30') are placed in communication with a respective tank (50) containing the fluid to be delivered.
- 15 18. Machine according to any one of the preceding claims, wherein said at least one module (30, 30') comprises a respective local control unit (60) of the operation of said heads (31), for managing the fluid delivery modes by the same.
19. Machine according to any one of the preceding claims, wherein said at least one module (30, 30') comprises a respective protection element (24) of said heads
20 (31), removably associated with the lower part of said second portion (34b) so as to completely cover the lower surface of said heads (31).
20. Machine according to any one of the preceding claims, comprising a plurality of modules (30, 30') associated with said support elements (20, 22) and side by side along said feed direction (A).

25

1/4

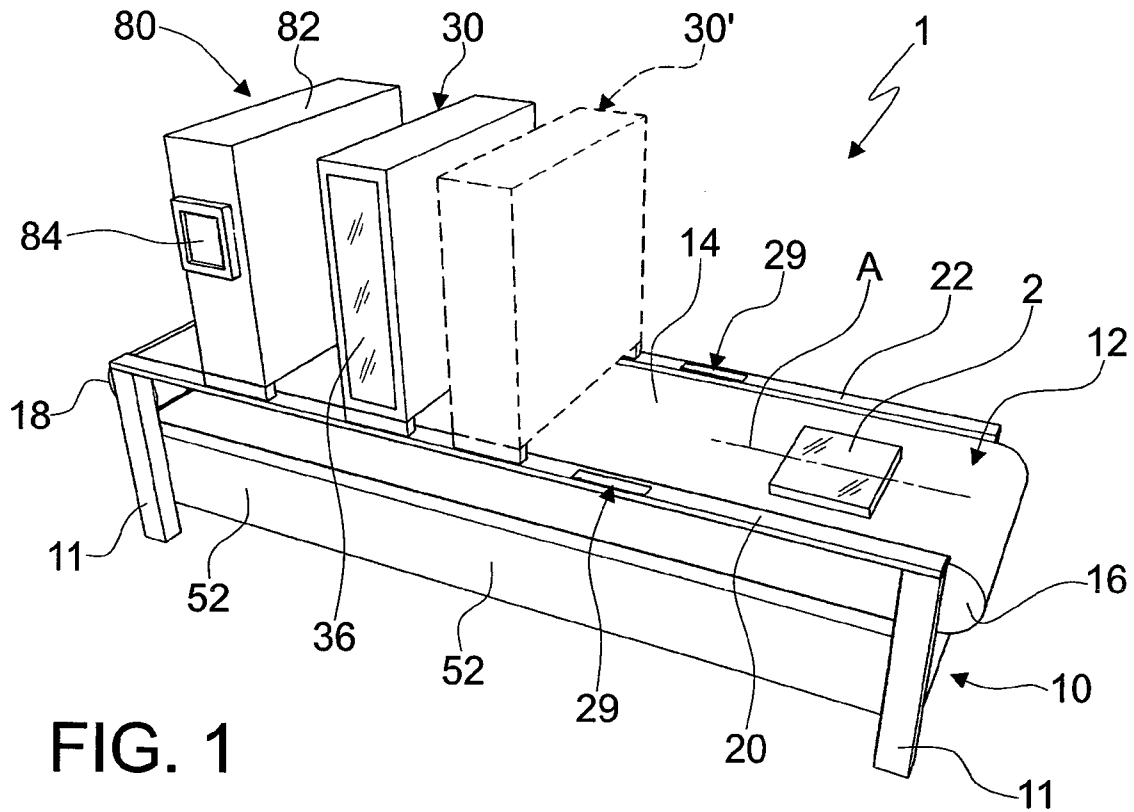

FIG. 1

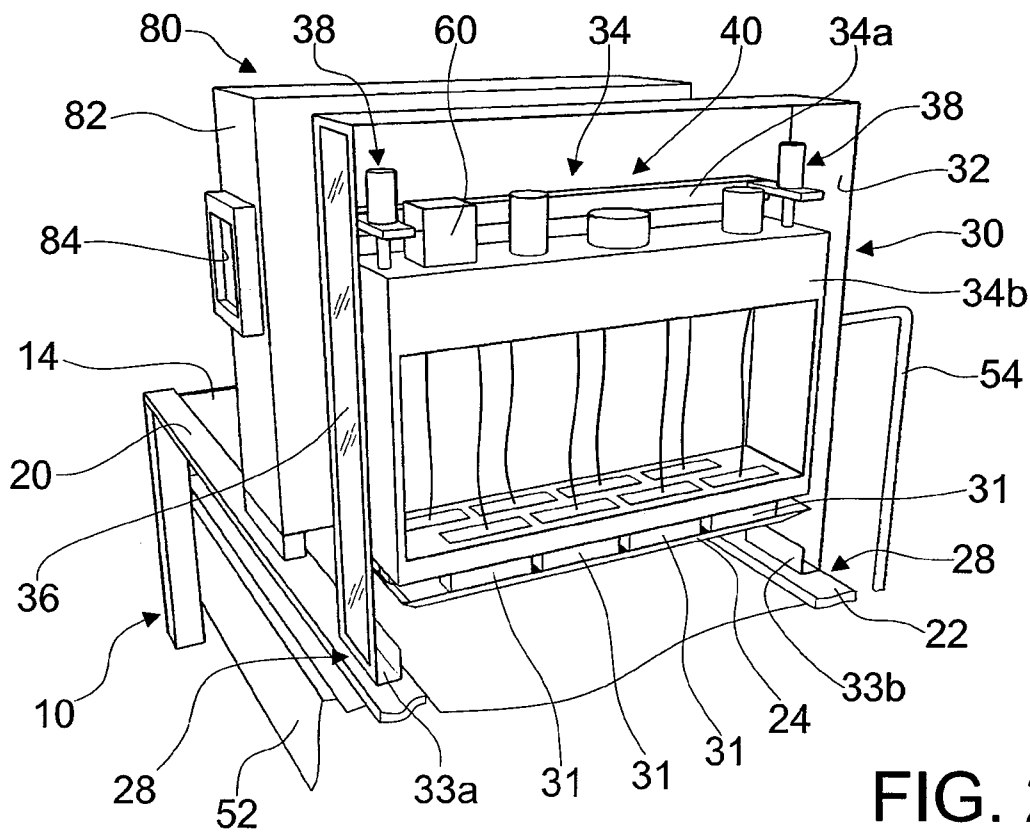

FIG. 2

2/4

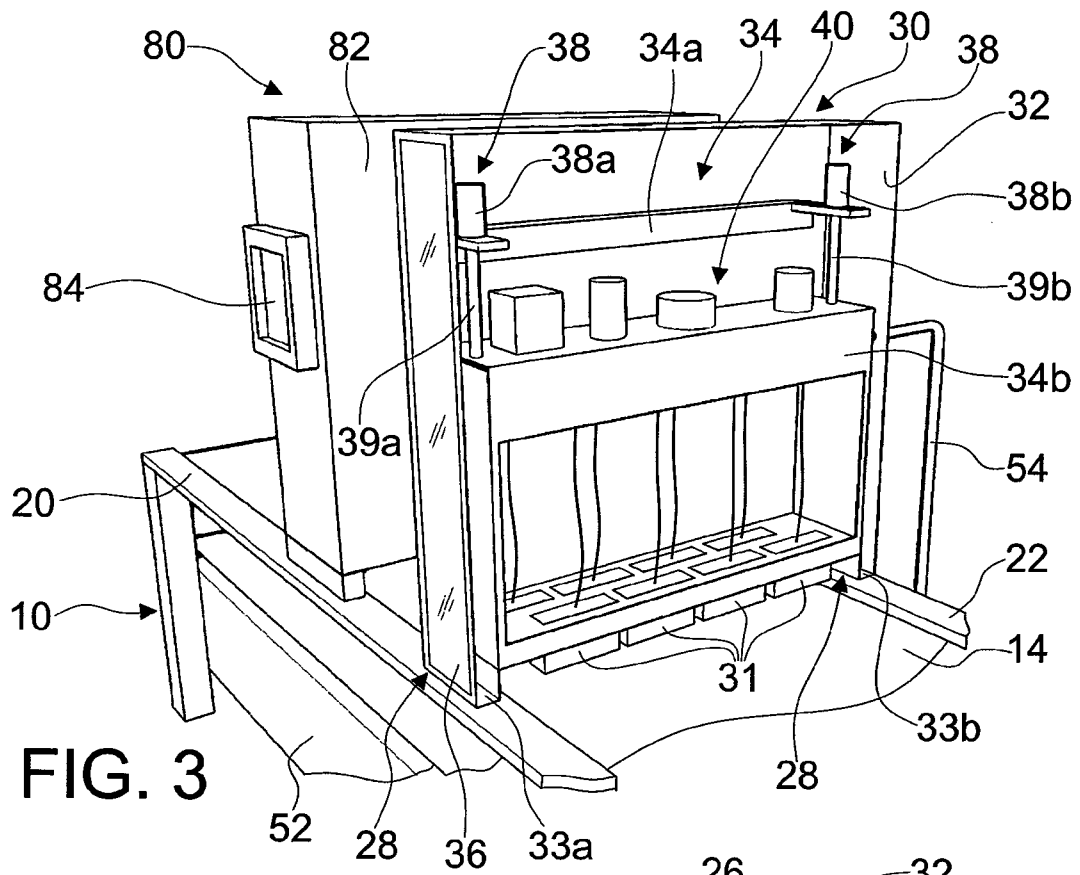

FIG. 3

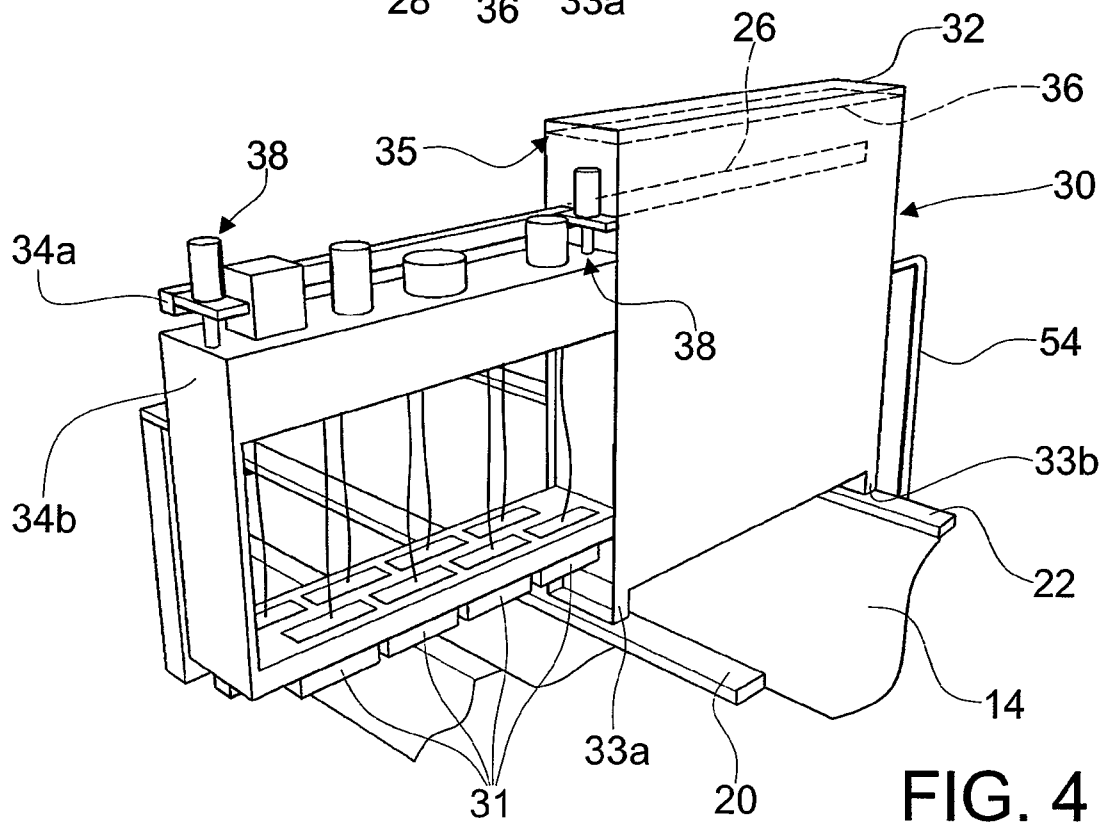

FIG. 4

3/4

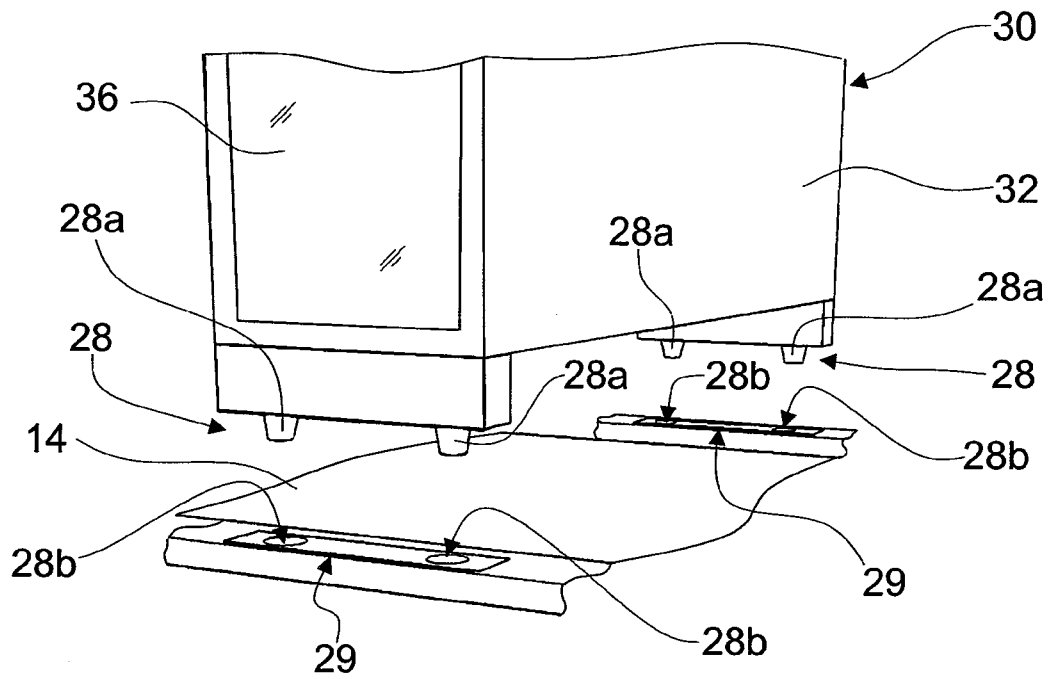

FIG. 5

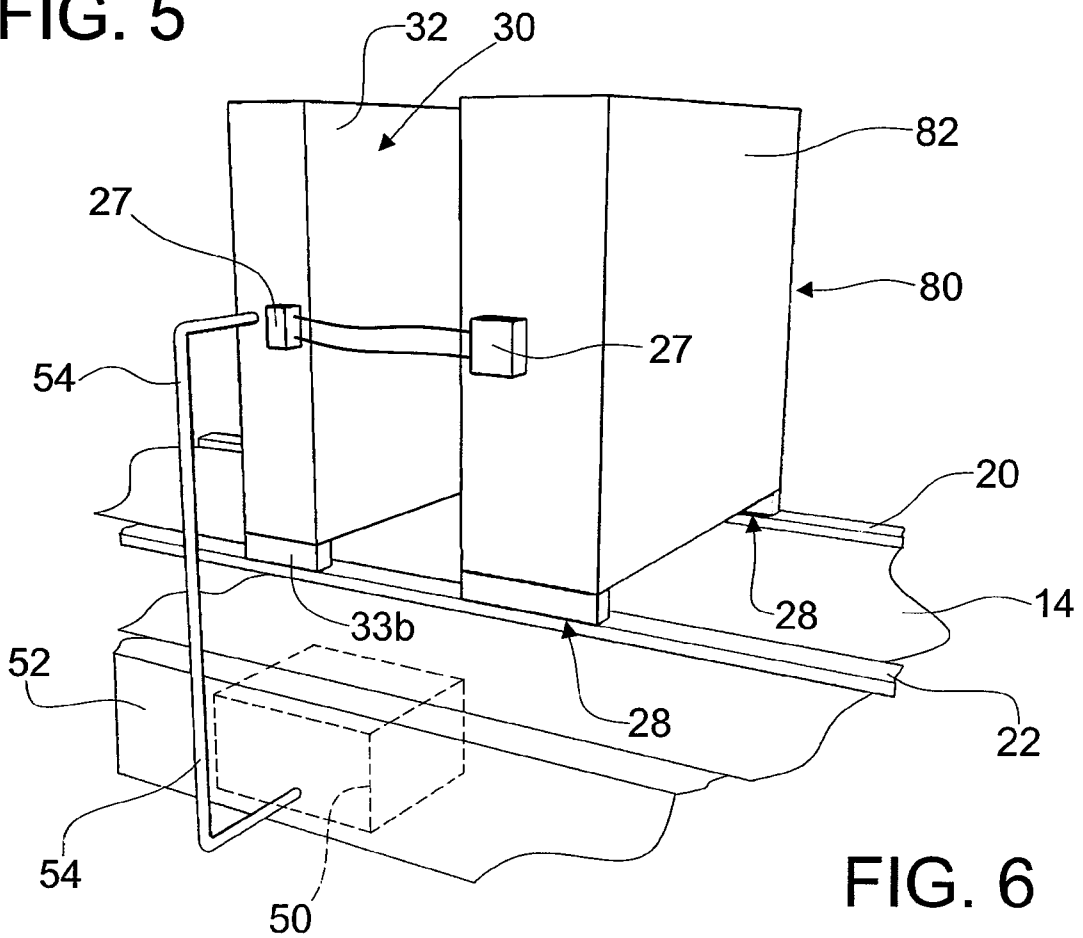

FIG. 6

4/4

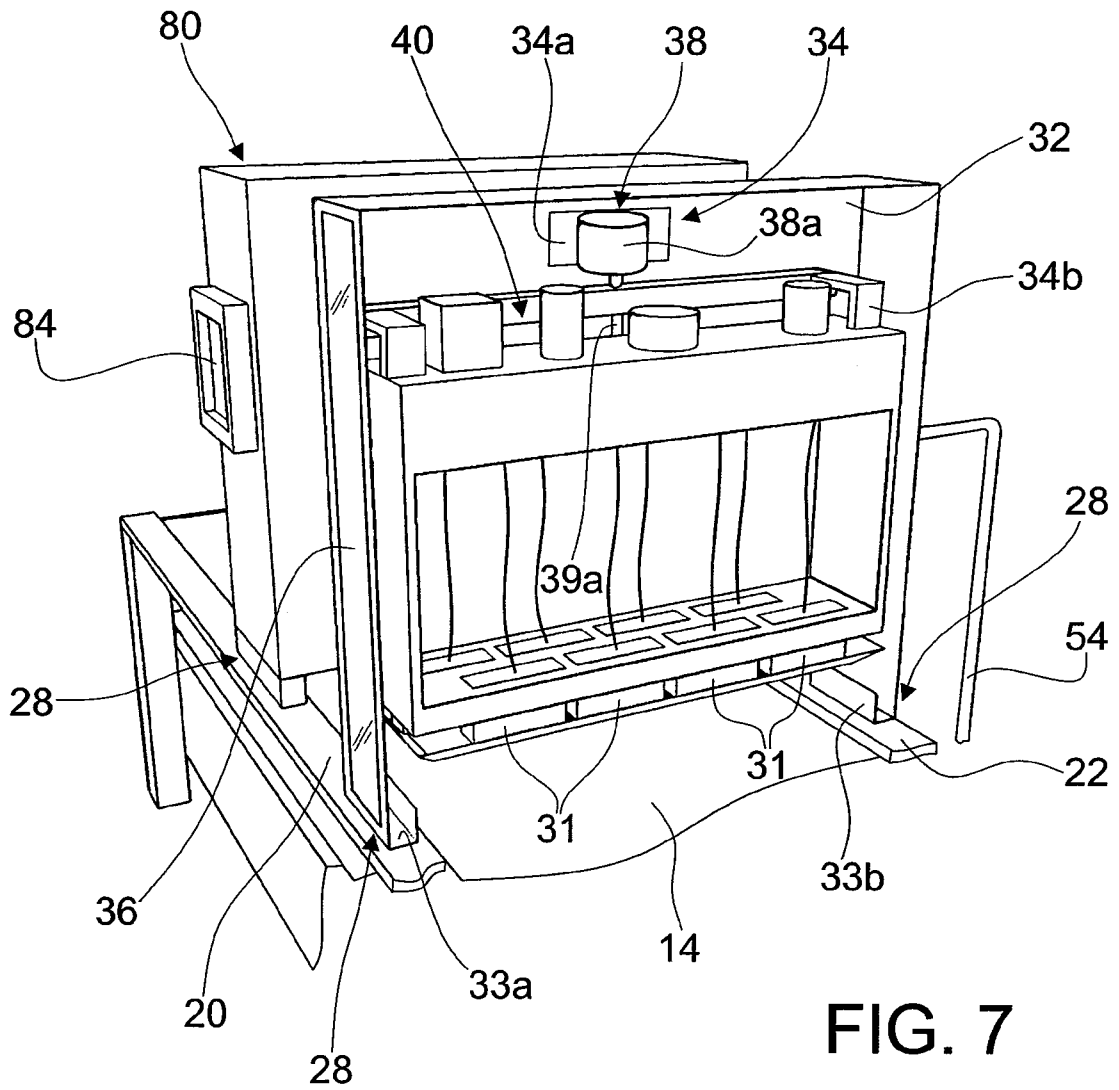

FIG. 7

INTERNATIONAL SEARCH REPORT

International application No
PCT/EP2014/079155

A. CLASSIFICATION OF SUBJECT MATTER
 INV. B41J25/308 B41J25/304 B41J25/34 B41J2/165
 ADD.
 According to International Patent Classification (IPC) or to both national classification and IPC

B. FIELDS SEARCHED
 Minimum documentation searched (classification system followed by classification symbols)
 B41J
 Documentation searched other than minimum documentation to the extent that such documents are included in the fields searched

Electronic data base consulted during the international search (name of data base and, where practicable, search terms used)
 EPO-Internal, WPI Data

C. DOCUMENTS CONSIDERED TO BE RELEVANT		
Category*	Citation of document, with indication, where appropriate, of the relevant passages	Relevant to claim No.
X	US 2012/070217 A1 (HENDRICKS JEFFREY T [US] ET AL) 22 March 2012 (2012-03-22) figures 2-4, 8, 14, 16 paragraph [0020] - paragraph [0023] paragraph [0032] paragraph [0035]	1-18
X	DE 10 2010 060406 A1 (OCE PRINTING SYSTEMS GMBH [DE]) 10 May 2012 (2012-05-10) figures 1,3,5-8 paragraph [0009] paragraph [0038] paragraph [0042] paragraph [0016]	1-8,19
	----- -/--	

Further documents are listed in the continuation of Box C.

See patent family annex.

* Special categories of cited documents :

<p>"A" document defining the general state of the art which is not considered to be of particular relevance</p> <p>"E" earlier application or patent but published on or after the international filing date</p> <p>"L" document which may throw doubts on priority claim(s) or which is cited to establish the publication date of another citation or other special reason (as specified)</p> <p>"O" document referring to an oral disclosure, use, exhibition or other means</p> <p>"P" document published prior to the international filing date but later than the priority date claimed</p>	<p>"T" later document published after the international filing date or priority date and not in conflict with the application but cited to understand the principle or theory underlying the invention</p> <p>"X" document of particular relevance; the claimed invention cannot be considered novel or cannot be considered to involve an inventive step when the document is taken alone</p> <p>"Y" document of particular relevance; the claimed invention cannot be considered to involve an inventive step when the document is combined with one or more other such documents, such combination being obvious to a person skilled in the art</p> <p>"&" document member of the same patent family</p>
---------------------------------------------------------------------------------------------------------------------------------------------------------------------------------------------------------------------------------------------------------------------------------------------------------------------------------------------------------------------------------------------------------------------------------------------------------------------------------------------------------------------------------------------------------------------------------------------------	-----------------------------------------------------------------------------------------------------------------------------------------------------------------------------------------------------------------------------------------------------------------------------------------------------------------------------------------------------------------------------------------------------------------------------------------------------------------------------------------------------------------------------------------------------------------------------------------------------------------------------------------------------------------------------------------------------------------

Date of the actual completion of the international search 15 September 2015	Date of mailing of the international search report 22/09/2015
---------------------------------------------------------------------------------------	-------------------------------------------------------------------------

Name and mailing address of the ISA/ European Patent Office, P.B. 5818 Patentlaan 2 NL - 2280 HV Rijswijk Tel. (+31-70) 340-2040, Fax: (+31-70) 340-3016	Authorized officer João, César
----------------------------------------------------------------------------------------------------------------------------------------------------------------------	------------------------------------------

INTERNATIONAL SEARCH REPORT

International application No
PCT/EP2014/079155

C(Continuation). DOCUMENTS CONSIDERED TO BE RELEVANT		
Category*	Citation of document, with indication, where appropriate, of the relevant passages	Relevant to claim No.
X	US 2013/293633 A1 (LI KE [CA] ET AL) 7 November 2013 (2013-11-07) figures 5-7, 10, 19 paragraph [0050] - paragraph [0052] paragraph [0055] -----	1-4,6, 17-20
X	US 2003/043226 A1 (BALCAN PETRICA DORINEL [US] ET AL) 6 March 2003 (2003-03-06) figures 1, 3-7, 11 paragraphs [0019], [0025], [0040], [0050] -----	1,2,17, 19
X	US 2014/340445 A1 (ACHATZ AUGUSTINUS [DE] ET AL) 20 November 2014 (2014-11-20) figures 3-4 the whole document -----	1,2,19
A	US 2011/043554 A1 (SILVERBROOK KIA [AU] ET AL) 24 February 2011 (2011-02-24) figure 8 paragraph [0197] -----	9

INTERNATIONAL SEARCH REPORT

Information on patent family members

International application No PCT/EP2014/079155

Patent document cited in search report	Publication date	Patent family member(s)	Publication date
US 2012070217	A1	22-03-2012	NONE

DE 102010060406	A1	10-05-2012	NONE

US 2013293633	A1	07-11-2013	EP 2844486 A1 11-03-2015
			US 2013293633 A1 07-11-2013
			WO 2013163749 A1 07-11-2013

US 2003043226	A1	06-03-2003	DE 60301038 D1 25-08-2005
			DE 60301038 T2 20-04-2006
			EP 1393912 A2 03-03-2004
			JP 2004082730 A 18-03-2004
			US 2003043226 A1 06-03-2003
			US 2004061735 A1 01-04-2004

US 2014340445	A1	20-11-2014	DE 102013105077 A1 20-11-2014
			JP 2014226938 A 08-12-2014
			US 2014340445 A1 20-11-2014

US 2011043554	A1	24-02-2011	AU 2010283968 A1 21-03-2013
			CA 2763376 A1 24-02-2011
			EP 2507060 A1 10-10-2012
			SG 178453 A1 29-03-2012
			US 2011043554 A1 24-02-2011
			US 2011043580 A1 24-02-2011
			US 2011043581 A1 24-02-2011
			US 2011043582 A1 24-02-2011
			US 2011043583 A1 24-02-2011
			US 2011043584 A1 24-02-2011
			US 2011043585 A1 24-02-2011
			US 2011043586 A1 24-02-2011
			WO 2011020152 A1 24-02-2011
