



(51) International Patent Classification:

A61B 90/98 (2016.01) A61C 3/00 (2006.01)
A61B 90/90 (2016.01) G06K 7/10 (2006.01)

(21) International Application Number:

PCT/FI2018/050196

(22) International Filing Date:

16 March 2018 (16.03.2018)

(25) Filing Language:

English

(26) Publication Language:

English

(30) Priority Data:

20175234 16 March 2017 (16.03.2017) FI

(71) Applicant: LM-INSTRUMENTS OY [FI/FI]; PL 88,
21601 Parainen (FI).

(72) Inventor: LENTO, Jaakko; c/o LM-Instruments Oy, PL
88, 21601 Parainen (FI).

(74) Agent: TAWAST, Juha; c/o Planmeca Oy, Asentajankatu
6, 00880 Helsinki (FI).

(81) Designated States (unless otherwise indicated, for every
kind of national protection available): AE, AG, AL, AM,
AO, AT, AU, AZ, BA, BB, BG, BH, BN, BR, BW, BY, BZ,
CA, CH, CL, CN, CO, CR, CU, CZ, DE, DJ, DK, DM, DO,
DZ, EC, EE, EG, ES, FI, GB, GD, GE, GH, GM, GT, HN,
HR, HU, ID, IL, IN, IR, IS, JO, JP, KE, KG, KH, KN, KP,
KR, KW, KZ, LA, LC, LK, LR, LS, LU, LY, MA, MD, ME,
MG, MK, MN, MW, MX, MY, MZ, NA, NG, NI, NO, NZ,
OM, PA, PE, PG, PH, PL, PT, QA, RO, RS, RU, RW, SA,
SC, SD, SE, SG, SK, SL, SM, ST, SV, SY, TH, TJ, TM, TN,
TR, TT, TZ, UA, UG, US, UZ, VC, VN, ZA, ZM, ZW.

(84) Designated States (unless otherwise indicated, for every
kind of regional protection available): ARIPO (BW, GH,
GM, KE, LR, LS, MW, MZ, NA, RW, SD, SL, ST, SZ, TZ,
UG, ZM, ZW), Eurasian (AM, AZ, BY, KG, KZ, RU, TJ,
TM), European (AL, AT, BE, BG, CH, CY, CZ, DE, DK,
EE, ES, FI, FR, GB, GR, HR, HU, IE, IS, IT, LT, LU, LV,

(54) Title: AN INSTRUMENT PRODUCT AND A METHOD FOR MANUFACTURING THE SAME

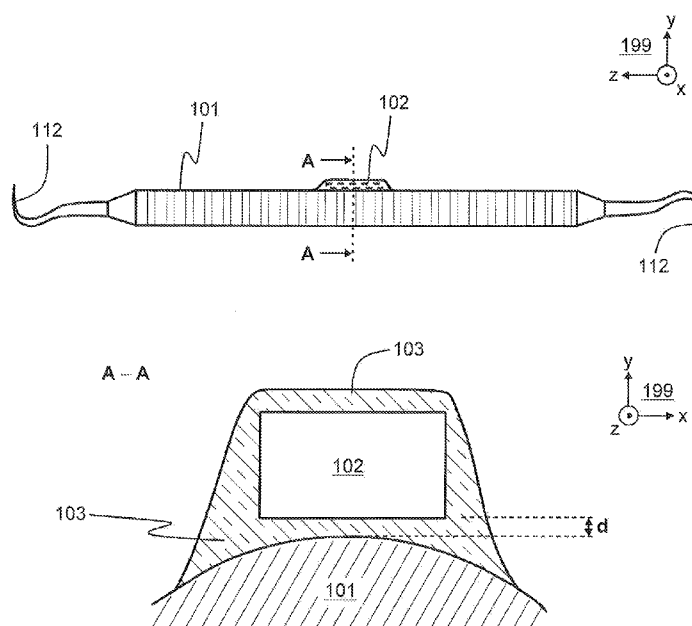

Figure 1a

(57) Abstract: An instrument product comprises a medical hand instrument (101) and a radio frequency identifier (102) readable from a distance away from the radio frequency identifier. The radio frequency identifier is at least partly covered with cover material (103) attached with adhesive material to a surface of the medical hand instrument so that the adhesive material is in contact with both the cover material and the surface of the medical hand instrument. The cover material can be the same material as the adhesive material, or the cover material may constitute a cover element which comprises a cavity for the radio frequency identifier and which is attached with the adhesive material to the surface of the medical hand instrument.



MC, MK, MT, NL, NO, PL, PT, RO, RS, SE, SI, SK, SM,
TR), OAPI (BF, BJ, CF, CG, CI, CM, GA, GN, GQ, GW,
KM, ML, MR, NE, SN, TD, TG).

Declarations under Rule 4.17:

- *as to the identity of the inventor (Rule 4.17(i))*
- *as to applicant's entitlement to apply for and be granted a patent (Rule 4.17(ii))*
- *of inventorship (Rule 4.17(iv))*

Published:

- *with international search report (Art. 21(3))*

An instrument product and a method for manufacturing the same

Field of the disclosure

The disclosure relates to an instrument product and to a method for manufacturing
5 the same. The instrument product comprises a medical hand instrument that can
be, for example but not necessarily, a dental or surgical instrument.

Background

In many cases, authorities and actors of the medical and/or dental field want to
have an infallible and traceable solution to follow instruments so as be able to
10 trace disinfection, sterilization, reparation, and other operations directed to or
carried out with the instruments under consideration. Nowadays, users do not
typically have the time and willingness to generate reports manually because of
the related workload. In addition, there is a risk of errors with manual data
recording and identification of instruments, which prevents regarding the manually
15 recorded data as an irrefutable proof of what has been done and what has been
not done.

WO2008062387 describes an instrument comprising a radio frequency identifier
"RFID". The radio frequency identifier is embedded in a polymer sheet that is
attached on a surface of the handle of the instrument. The polymer sheet that
20 includes the radio frequency identifier can be, for example, wrapped around the
handle of the instrument. In order to obtain an even surface, it is possible to
provide the instrument with a recess corresponding in size to the polymer sheet. In
an advantageous embodiment described in WO2008062387, the polymer sheet
comprises two layers between which the radio frequency identifier is located. The
25 two layers are made of materials having different hardness. The layer of the
harder material is against the instrument in order to obtain a better adhesion. The
softer material protects the radio frequency identifier against external mechanical
impacts. It may be, however, in some circumstances hard to guarantee that the
polymer sheet remains firmly attached to the handle of the instrument.
30 Furthermore, in some cases the shape of the handle may deviate from a

cylindrical shape so that slits are left between the polymer sheet and the handle when the polymer sheet is wrapped around the handle. The slits are undesirable because, in some circumstances, they may collect impurities. For example, the shape of handles of pliers deviates typically significantly from a cylindrical shape.

5 Summary

The following presents a simplified summary in order to provide a basic understanding of some aspects of various embodiments of the invention. The summary is not an extensive overview of the invention. It is neither intended to identify key or critical elements of the invention nor to delineate the scope of the invention. The following summary merely presents some concepts of the invention in a simplified form as a prelude to a more detailed description of exemplifying embodiments of the invention.

In accordance with the invention, there is provided a new instrument product that comprises:

- 15 - a medical hand instrument, and
- a radio frequency identifier "RFID" on a surface of the medical hand instrument, the radio frequency identifier being readable from a distance away from the radio frequency identifier.

In one preferable embodiment,

- 20 - the radio frequency identifier has an elongated shape and an end-portion of the radio frequency identifier is capable of emitting stronger radiation than another end-portion of the radio frequency identifier,
- the surface of the medical hand instrument is a surface of an elongated element of the medical hand instrument, and
- 25 - the radio frequency identifier is located at an end-portion of the elongated element of the medical hand instrument so that i) longitudinal directions of the elongated element of the medical hand instrument and the radio frequency identifier are substantially parallel with each other and ii) the end-

portion (210) of the radio frequency identifier capable of emitting stronger radiation points towards a middle area of the medical hand instrument.

The radio frequency identifier is at least partly covered with cover material attached with adhesive material to the surface of the medical hand instrument so
5 that the adhesive material is in contact with both the cover material and the surface of the medical hand instrument. The cover material can be the same material as the adhesive material and it can be arranged, e.g. cast or dispensed, to cover the radio frequency identifier after the radio frequency identifier has been attached to the surface of the medical hand instrument or simultaneously when the
10 radio frequency identifier is being attached to the surface of the medical hand instrument. Alternatively, the cover material may constitute a cover element which comprises a cavity for the radio frequency identifier and which is attached with the adhesive material to the surface of the medical hand instrument. The adhesive material is dispensable in fluidic form prior to its curing, and thus the adhesive
15 material can adapt with different shapes of the surface of the medical hand instrument. Therefore, slits which may collect impurities in some circumstances can be avoided. The adhesive material can be for example suitable silicone based adhesive or suitable epoxy resin based adhesive.

The above-mentioned medical hand instrument can be, for example but not
20 necessarily, a dental or surgical hand instrument.

In accordance with the invention, there is provided also a new method for manufacturing an instrument product that comprises a medical hand instrument and a radio frequency identifier readable from a distance away from the radio frequency identifier.

25 The method comprises placing the radio frequency identifier on a surface of the medical hand instrument and covering the radio frequency identifier at least partly with cover material so that the cover material gets attached with adhesive material to the surface of the medical hand instrument so that the adhesive material is in contact with both the cover material and the surface of the medical hand
30 instrument, wherein the adhesive material is dispensed in fluidic form and allowed to cure.

In one preferable embodiment of the above-mentioned method:

- the radio frequency identifier has an elongated shape and an end-portion of the radio frequency identifier is capable of emitting stronger radiation than another end-portion of the radio frequency identifier,
- 5 - the surface of the medical hand instrument is a surface of an elongated element of the medical hand instrument, and
- the radio frequency identifier is placed on an end-portion of the elongated element of the medical hand instrument so that i) longitudinal directions of the elongated element of the medical hand instrument and the radio
10 frequency identifier are substantially parallel with each other and ii) the end-portion of the radio frequency identifier capable of emitting stronger radiation points towards a middle area of the medical hand instrument.

A number of exemplifying and non-limiting embodiments of the invention are described in accompanied dependent claims.

15 Various exemplifying and non-limiting embodiments of the invention both as to constructions and to methods of operation, together with additional objects and advantages thereof, will be best understood from the following description of specific exemplifying and non-limiting embodiments when read in connection with the accompanying drawings.

20 The verbs "to comprise" and "to include" are used in this document as open limitations that neither exclude nor require the existence of un-recited features. The features recited in dependent claims are mutually freely combinable unless otherwise explicitly stated. Furthermore, it is to be understood that the use of "a" or "an", i.e. a singular form, throughout this document does not exclude a plurality.

25 **Brief description of the figures**

Exemplifying and non-limiting embodiments of the invention and their advantages are explained in greater detail below in the sense of examples and with reference to the accompanying drawings, in which:

figures 1a and 1b illustrate an instrument product according to an exemplifying and non-limiting embodiment of the invention,

figures 2a, 2b, and 2c illustrate an instrument product according to another exemplifying and non-limiting embodiment of the invention,

5 figures 3a, 3b, and 3c illustrate a manufacturing process of a detail of an instrument product according to an exemplifying and non-limiting embodiment of the invention, and figure 3d illustrates a detail of an instrument product according to an exemplifying and non-limiting embodiment of the invention

10 figures 4a, 4b, and 4c illustrate a manufacturing process of a detail of an instrument product according to an exemplifying and non-limiting embodiment of the invention,

figures 5a, 5b, and 5c illustrate a detail of an instrument product according to an exemplifying and non-limiting embodiment of the invention, and

15 figure 6 shows a flowchart of a method according to an exemplifying and non-limiting embodiment of the invention for manufacturing an instrument product.

Description of exemplifying and non-limiting embodiments

20 The specific examples provided in the description below should not be construed as limiting the scope and/or the applicability of the accompanied claims. Lists and groups of examples provided in the description are not exhaustive unless otherwise explicitly stated.

Figure 1a shows a side-view of an instrument product according to an exemplifying and non-limiting embodiment of the invention. Figure 1a shows also a part of a section taken along a line A-A so that the section plane is parallel with the xy-plane of a coordinate system 199. Figure 1b shows a part of the instrument product when seen along the negative y-direction of the coordinate system 199. The instrument product comprises a medical hand instrument 101 and a radio frequency identifier "RFID" 102 that can be, for example but not necessarily, a ceramic radio frequency identifier tag. In figure 1b and in the side-view shown in

figure 1a, the radio frequency identifier 102 is depicted with dashed lines. The radio frequency identifier 102 is readable from a distance away from the radio frequency identifier. The radio frequency identifier 102 may comprise, for example but not necessarily, a memory circuit capable of storing digital information. The digital information may contain for example identifying information identifying the medical hand instrument 101 as an individual object from among similar medical hand instruments and/or information indicating e.g. the date of manufacture of the medical hand instrument, the manufacturer of the medical hand instrument and/or other information related directly or indirectly to the medical hand instrument. Furthermore, the digital information may indicate the number of maintenance and/or sterilization cycles. It is however also possible that the radio frequency identifier 102 does not comprise any memory circuit but identification information related to the radio frequency identifier 102 is represented by e.g. radiation properties of the radio frequency identifier 102. In the exemplifying case illustrated in figures 1a and 1b, the medical hand instrument 101 is a dental instrument suitable for e.g. removing dental calculus. The medical hand instrument comprises operative portions 112 for performing the operations according to the purpose of use of the medical hand instrument. The medical hand instrument 101 further comprises a handle that is mechanically connected to the operative portions 112 as illustrated in figure 1a.

In the exemplifying instrument product illustrated in figures 1a and 1b, the radio frequency identifier 102 is covered with adhesive material 103 that attaches to a surface of the medical hand instrument 101. The adhesive material 103 is such that it is dispensable in fluidic form prior to its curing. The adhesive material 103 can be for example suitable silicone based adhesive. In many cases, the surface of the medical hand instrument 101 is advantageously pretreated with suitable primer, e.g. silane, in order to provide a better attachment between the adhesive material 103 and the medical hand instrument 101. The above-mentioned surface of the medical hand instrument 101 can be a metal surface or a surface of some other material such as e.g. plastic. As the adhesive material 103 is fluidic prior to its curing, the adhesive material 103 can adapt with different shapes of the surface of the medical hand instrument 101 and thereby slits which may collect impurities

in some circumstances can be avoided. In the exemplifying medical hand instrument 101, the handle comprises circumferential grooves so as to provide a better grip. The adhesive material 103 which is fluidic prior to its curing can adapt with the circumferential grooves of the handle.

5 In the exemplifying instrument product illustrated in figures 1a and 1b, the radio frequency identifier 102 is fully covered with the adhesive material 103. It is, however, also possible that e.g. the upper surface of the radio frequency identifier is not covered by the adhesive material 103. In an instrument product according
10 an exemplifying and non-limiting embodiment of the invention, at least 90 % of the surface area the radio frequency identifier is covered by the adhesive material. In an instrument product according an exemplifying and non-limiting embodiment of the invention, at least 95 % of the surface area the radio frequency identifier is covered by the adhesive material.

In cases where the handle of the medical hand instrument 101 is made of metal or
15 comprises metal, the medical hand instrument 101 can act as an external antenna for the radio frequency identifier 102. In order to achieve proper antenna operation, the radio frequency identifier 102 is advantageously positioned so that the distance d between the surface of the medical hand instrument 101 and the
20 radio frequency identifier 102 is less than 1 mm, more advantageously less than 0.5 mm, yet more advantageously less than 0.2 mm, and yet more advantageously less than 0.05 mm. The radio frequency used by the radio frequency identifier 102 is advantageously selected so that the wavelength of the radio waves is compatible with the physical length of the medical hand instrument
101. The wave length of the radio waves can be about e.g. 300 mm.

25 Figure 2a shows side-views of an instrument product according to an exemplifying and non-limiting embodiment of the invention. Figure 2b shows a part of a section taken along a line A-A shown in figure 2a. Figure 2c shows a part of a section taken along a line B-B shown in figure 2a. The section plane related to figure 2b is parallel with the xy-plane of a coordinate system 299, and the section plane
30 related to figure 2c is parallel with the xz-plane of the coordinate system 299. The instrument product comprises a medical hand instrument 201 and a radio

frequency identifier "RFID" 202. In figure 2a, the radio frequency identifier 202 is depicted with dashed lines. The radio frequency identifier "RFID" 102 is readable from a distance away from the radio frequency identifier. The radio frequency identifier 202 is covered with adhesive material 203 that attaches to a surface of the medical hand instrument 201. In the exemplifying case illustrated in figures 2a-2c, the medical hand instrument 201 is tweezers.

In the exemplifying instrument products illustrated in figures 1a and 1b and in figures 2a-2c, the radio frequency identifier is located on a surface of an elongated element of the medical hand instrument. In the instrument product illustrated in figures 1a and 1b, the elongated element is the handle of the medical hand instrument 101. In the instrument product illustrated in figures 2a-2c, the elongated element is a metal strip constituting one half of the tweezers. Concerning the operation of the radio frequency identifier, the radio frequency identifier is located advantageously in the middle area of the above-mentioned elongated element as is the case in the instrument product illustrated in figures 1a and 1b. In the instrument product illustrated in figures 2a-2c, the radio frequency identifier 202 is placed on the head of the tweezers because the radio frequency identifier might disturb a user of the tweezers if the radio frequency identifier 202 were placed in the middle of the metal strip constituting the one half of the tweezers.

In the exemplifying instrument products illustrated in figures 1a and 1b and in figures 2a-2c, the radio frequency identifier has an elongated shape and the longitudinal direction of the radio frequency identifier is substantially parallel with the longitudinal direction of the above-mentioned elongated element of the medical hand instrument. In the exemplifying instrument product illustrated in figures 2a-2c, the radio frequency identifier 202 is positioned so that an end-portion 210 of the radio frequency identifier 202 that is capable of emitting stronger radiation than the other end-portion 211 of the radio frequency identifier 202 points towards the middle area of the medical hand instrument 201. This arrangement improves the operation of the radio frequency identifier 202 in this instrument product where the radio frequency identifier 202 is on the head of the tweezers, i.e. not in the middle area of the metal strip constituting the one half of the tweezers.

Figures 3a, 3b, and 3c illustrate a manufacturing process of a detail of an instrument product according to an exemplifying and non-limiting embodiment of the invention. Each of figures 3a-3c shows a section view where the section plane is parallel with the xy-plane of a coordinate system 399. The instrument product comprises a medical hand instrument 301 a part of which is shown in figures 3a-3c. Furthermore, the instrument product comprises a radio frequency identifier 302. In this exemplifying case, a mold element 305 is used in the manufacture of the instrument product. Figure 3a illustrates a situation where the radio frequency identifier 302 has been placed on a surface of the medical hand instrument 301 and the mold element 315 has been placed to surround the radio frequency identifier 302. Figure 3b illustrates a situation where adhesive material 303 is injected via an aperture 313 of the mold element 305 into free spaces in the mold element 305. Figure 3c illustrates a situation where the adhesive material 303 has cured, i.e. solidified, and the mold element 305 has been removed. In this exemplifying case, the shape of a surface 306 of the solidified adhesive material 303 is determined by the mold element 305. As the mold element 305 is removed, the surface 306 of the solidified adhesive material constitutes a part of the outer surface of the instrument product. It is also possible that the mold element 305 is not removed and thereby the mold element 305 is an element of the instrument product. Figure 3d show a section view of a detail of an instrument product where the mold element 305' is an element of the instrument product. As illustrated in figure 3d, the mold element 305' is designed so that the adhesive material 303 binds the mold element 305' to be an element of the instrument product.

Figures 4a, 4b, and 4c illustrate a manufacturing process of a detail of an instrument product according to an exemplifying and non-limiting embodiment of the invention. Each of figures 4a-4c shows a section view where the section plane is parallel with the xy-plane of a coordinate system 499. The instrument product comprises a medical hand instrument 401 a part of which is shown in figure 4c. Furthermore, the instrument product comprises a radio frequency identifier 402. In this exemplifying case, a mold element 405 is used in the manufacture of the instrument product. Figure 4a illustrates a situation where the radio frequency identifier 402 has been placed on the bottom of the mold element 405. Figure 4b

illustrates a situation where free spaces in the mold element 405 have been filled with adhesive material 403. Figure 4c illustrates a situation where the mold element 405 containing the adhesive material 403 and the radio frequency identifier 402 has been pressed against the surface of the medical hand instrument 401. As shown in figure 4c, a part of the adhesive material 403 is extruded out from the mold element 405.

Figures 5a, 5b, and 5c illustrate a detail of an instrument product according to an exemplifying and non-limiting embodiment of the invention. The instrument product comprises a medical hand instrument 501 a part of which is shown in figure 5c. The instrument product comprises a radio frequency identifier 502. In this exemplifying case, the instrument product further comprises a cover element 507 made of suitable cover material 504. Each of figures 5b and 5c shows a section view where the section plane is parallel with the xy-plane of a coordinate system 599. Figure 5a shows a bottom view of the cover element 507. The cover element 507 comprises a cavity for the radio frequency identifier 502. As illustrated in figure 5c, the cover element 507 is attached with adhesive material 503 to the surface of the medical hand instrument 501 so that the cavity opens towards the surface of the medical hand instrument 501. The cover element 507 is advantageously made of flexible material and the cavity is advantageously dimensioned so that the cover element 507 gets stretched in response to insertion of the radio frequency identifier 502 in the cavity. Thus, the radio frequency identifier 502 is held in the cavity by friction force. This facilitates the process for attaching the combination of the cover element 507 and the radio frequency identifier 502 to the surface of the medical hand instrument 501. It is also possible that the edge portion of the cavity is provided with one or more claw sections 508 and 509 for shape-locking the radio frequency identifier 502 inside the cavity of the cover element 507.

In instrument products according to exemplifying and non-limiting embodiments of the invention, the cover material that at least partly covers the radio frequency identifier is advantageously flexible and soft enough to protect the radio frequency identifier against external mechanical impacts. It is advantageous that the cover material and also the adhesive material after curing are flexible because different materials of the instrument product may have different coefficients of thermal

expansion and the flexibility reduces mechanical stresses caused by differences in thermal expansions.

The materials of instrument products according to exemplifying and non-limiting embodiments of the invention are advantageously selected so that the instrument products are suitable for autoclave sterilization with sufficient temperature and duration and for a sufficient number of sterilization cycles. The sterilization temperature can be e.g. 134°C or 121°C, and the duration of each sterilization cycle can be e.g. 3-6 minutes or sometimes more. An instrument product is advantageously capable of withstanding at least 1000 sterilization cycles of the kind mentioned above.

Figure 6 shows a flowchart of a method according to an exemplifying and non-limiting embodiment of the invention for manufacturing an instrument product that comprises a medical hand instrument and a radio frequency identifier readable from a distance away from the radio frequency identifier. The method comprises at least the following action:

action 601: placing the radio frequency identifier on a surface of the medical hand instrument and covering the radio frequency identifier at least partly with cover material so that the cover material gets attached with adhesive material to the surface of the medical hand instrument so that the adhesive material is in contact with both the cover material and the surface of the medical hand instrument, wherein the adhesive material is dispensed in fluidic form and allowed to cure.

In a method according to an exemplifying and non-limiting embodiment of the invention, the cover material is the same material as the adhesive material, and the covering is carried out by dispensing or casting the adhesive material in fluidic form to cover at least partly the radio frequency identifier attached with the adhesive material to the surface of the medical hand instrument.

A method according to an exemplifying and non-limiting embodiment of the invention comprises covering at least 90 % of surface area the radio frequency identifier with the adhesive material.

A method according to an exemplifying and non-limiting embodiment of the invention comprises covering at least 95 % of surface area the radio frequency identifier with the adhesive material.

5 A method according to an exemplifying and non-limiting embodiment of the invention comprises placing a mold element to surround the radio frequency identifier when the radio frequency identifier is on the surface of the medical hand instrument and injecting the adhesive material into the mold element. The method may further comprise removing the mold element from the instrument product. It is also possible that the mold element is not removed from the instrument product,
10 i.e. the mold element is not only a tool used in the manufacture of the instrument product but also an element of the instrument product.

A method according to an exemplifying and non-limiting embodiment of the invention comprises placing the radio frequency identifier and the adhesive material into a mold element, and pressing the mold element containing the
15 adhesive material and the radio frequency identifier against the surface of the medical hand instrument. The method may further comprise removing the mold element from the instrument product. It is also possible that the mold element is not removed from the instrument product.

In a method according to an exemplifying and non-limiting embodiment of the
20 invention, the above-mentioned cover material constitutes a cover element comprising a cavity. In this exemplifying case, the method comprises inserting the radio frequency identifier in the cavity and then attaching the cover element to the surface of the medical hand instrument with the adhesive material so that the cavity opens towards the surface of the medical hand instrument. In a method
25 according to an exemplifying and non-limiting embodiment of the invention, the cavity is dimensioned so that the cover element gets stretched when the radio frequency identifier is inserted in the cavity. In a method according to an exemplifying and non-limiting embodiment of the invention, an edge portion of the cavity is provided with at least one claw section for shape-locking the radio
30 frequency identifier inside the cavity.

A method according to an exemplifying and non-limiting embodiment of the invention comprises positioning the radio frequency identifier so that the distance between the surface of the medical hand instrument and the radio frequency identifier is less than 1 mm, more advantageously less than 0.5 mm, yet more advantageously less than 0.2 mm, and yet more advantageously less than 0.05 mm.

In a method according to an exemplifying and non-limiting embodiment of the invention, the above-mentioned surface of the medical hand instrument is a surface of an elongated element of the medical hand instrument and the radio frequency identifier is placed substantially in the middle area of the elongated element of the medical hand instrument.

In a method according to an exemplifying and non-limiting embodiment of the invention, the radio frequency identifier has an elongated shape and the radio frequency identifier is attached to the medical hand instrument so that the longitudinal direction of the radio frequency identifier is substantially parallel with the longitudinal direction of the above-mentioned elongated element of the medical hand instrument.

A method according to an exemplifying and non-limiting embodiment of the invention comprises attaching the radio frequency identifier to an end-portion of an elongated element of the medical hand instrument so that the longitudinal directions of the elongated element of the medical hand instrument and the radio frequency identifier are substantially parallel with each other and an end-portion of the radio frequency identifier capable of emitting stronger radiation than the other end-portion of the radio frequency identifier points towards the middle area of the elongated element of the medical hand instrument.

The specific examples provided in the description given above should not be construed as limiting the scope and/or the applicability of the appended claims. Lists and groups of examples provided in the description given above are not exhaustive unless otherwise explicitly stated.

What is claimed is:

1. An instrument product comprising:

- a medical hand instrument (101, 201, 301, 401, 501), and
- a radio frequency identifier (102, 202, 302, 402, 502) on a surface of the
5 medical hand instrument, the radio frequency identifier being readable from
a distance away from the radio frequency identifier,

characterized in that the radio frequency identifier is at least partly covered with
cover material (103, 203, 303, 403, 504) attached with adhesive material (103,
203, 303, 403, 503) to the surface of the medical hand instrument so that the
10 adhesive material is in contact with both the cover material and the surface of the
medical hand instrument, the adhesive material being dispensable in fluidic form
prior to curing.

2. An instrument product according to claim 1, wherein the cover material (103,
203, 303, 403) is same material as the adhesive material (103, 203, 303, 403).

15 3. An instrument product according to claim 2, wherein at least 90 % of surface
area the radio frequency identifier is covered by the adhesive material.

4. An instrument product according to claim 2, wherein at least 95 % of surface
area the radio frequency identifier is covered by the adhesive material.

20 5. An instrument product according to any of claims 2-4, wherein a shape of a
surface (306) of a portion the adhesive material (303) covering the radio frequency
identifier is at least partly determined by a mold element.

6. An instrument product according to claim 5, wherein the instrument product
comprises the mold element (405).

25 7. An instrument product according to claim 5, wherein the surface (306) whose
shape is at least partly determined by the mold element constitutes a part of an
outer surface of the instrument product.

8. An instrument product according to claim 1, wherein the cover material (504) constitutes a cover element (507) comprising a cavity, the radio frequency identifier (502) being located in the cavity and the cover element being attached with the adhesive material (503) to the surface of the medical hand instrument so
5 that the cavity opens towards the surface of the medical hand instrument.

9. An instrument product according to claim 8, wherein the cavity is dimensioned so that the cover element (507) gets stretched in response to insertion of the radio frequency identifier in the cavity.

10. An instrument product according to claim 8 or 9, wherein an edge portion of
10 the cavity is provided with at least one claw section (508, 509) for shape-locking the radio frequency identifier inside the cavity.

11. An instrument product according to any of claims 1-10, wherein a distance (d) between the surface of the medical hand instrument and the radio frequency identifier is less than 1 mm.

15 12. An instrument product according to any of claims 1-11, wherein the radio frequency identifier is a ceramic radio frequency identifier tag.

13. An instrument product according to any of claims 1-12, wherein the surface of the medical hand instrument is a metal surface.

20 14. An instrument product according to any of claims 1-13, wherein the surface of the medical hand instrument (101) is a surface of an elongated element of the medical hand instrument (101), and the radio frequency identifier (102) is located substantially in a middle area of the elongated element of the medical hand instrument.

25 15. An instrument product according to claim 14, wherein the radio frequency identifier (102, 202) has an elongated shape and a longitudinal direction of the radio frequency identifier is substantially parallel with a longitudinal direction of the elongated element of the medical hand instrument.

16. An instrument product according to any of claims 1-13, wherein the surface of the medical hand instrument (201) is a surface of an elongated element of the medical hand instrument, the radio frequency identifier (202) has an elongated shape, the radio frequency identifier is located at an end-portion of the elongated
5 element of the medical hand instrument so that longitudinal directions of the elongated element of the medical hand instrument and the radio frequency identifier are substantially parallel with each other and an end-portion (210) of the radio frequency identifier capable of emitting stronger radiation than another end-portion (211) of the radio frequency identifier points towards a middle area of the
10 medical hand instrument.

17. An instrument product according to any of claims 1-13, wherein

- the radio frequency identifier (202) has an elongated shape and an end-portion (210) of the radio frequency identifier is capable of emitting stronger radiation than another end-portion (211) of the radio frequency identifier,
- 15 - the surface of the medical hand instrument (201) is a surface of an elongated element of the medical hand instrument, and
- the radio frequency identifier is located at an end-portion of the elongated element of the medical hand instrument so that i) longitudinal directions of the elongated element of the medical hand instrument and the radio
20 frequency identifier are substantially parallel with each other and ii) the end-portion (210) of the radio frequency identifier capable of emitting stronger radiation points towards a middle area of the medical hand instrument.

18. A method for manufacturing an instrument product that comprises a medical hand instrument and a radio frequency identifier readable from a distance away
25 from the radio frequency identifier, the method comprising placing (601) the radio frequency identifier on a surface of the medical hand instrument, **characterized** in that the method comprises covering (601) the radio frequency identifier at least partly with cover material so that the cover material gets attached with adhesive material to the surface of the medical hand instrument so that the adhesive
30 material is in contact with both the cover material and the surface of the medical

hand instrument, wherein the adhesive material is dispensed in fluidic form and allowed to cure.

19. A method according to claim 17, wherein the cover material is same material as the adhesive material, and the covering is carried out by dispensing or casting
5 the adhesive material in fluidic form to cover at least partly the radio frequency identifier.

20. A method according to claim 18, wherein the method comprises placing a mold element to surround the radio frequency identifier when the radio frequency identifier is on the surface of the medical hand instrument, and injecting the
10 adhesive material into the mold element.

21. A method according to claim 18, wherein the method comprises placing the radio frequency identifier and the adhesive material into a mold element, and pressing the mold element containing the adhesive material and the radio frequency identifier against the surface of the medical hand instrument.

15 22. A method according to claim 19 or 20, wherein the method comprises removing the mold element from the medical hand instrument.

23. A method according to claim 19 or 20, wherein

- the radio frequency identifier has an elongated shape and an end-portion of the radio frequency identifier is capable of emitting stronger radiation than another
20 end-portion of the radio frequency identifier,
- the surface of the medical hand instrument is a surface of an elongated element of the medical hand instrument, and
- the radio frequency identifier is placed on an end-portion of the elongated element of the medical hand instrument so that i) longitudinal directions of the
25 elongated element of the medical hand instrument and the radio frequency identifier are substantially parallel with each other and ii) the end-portion of the radio frequency identifier capable of emitting stronger radiation points towards a middle area of the medical hand instrument.

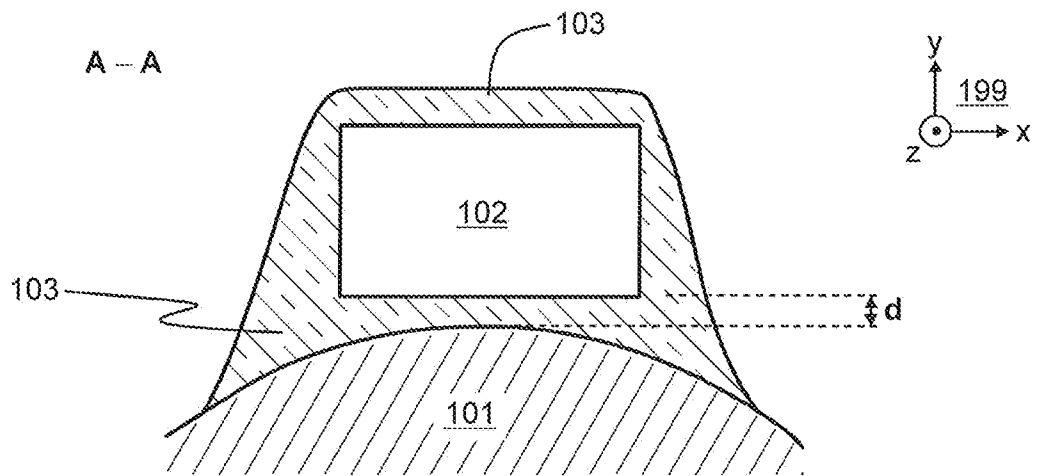
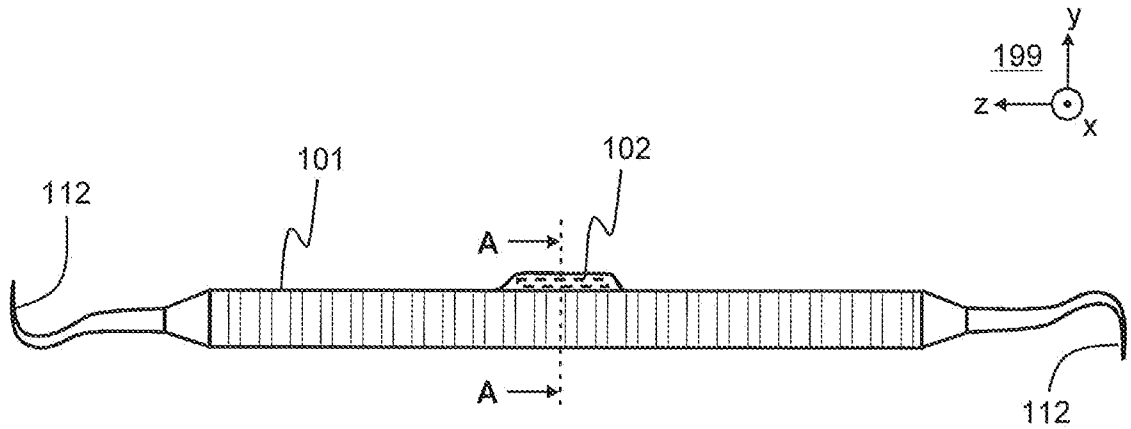

Figure 1a

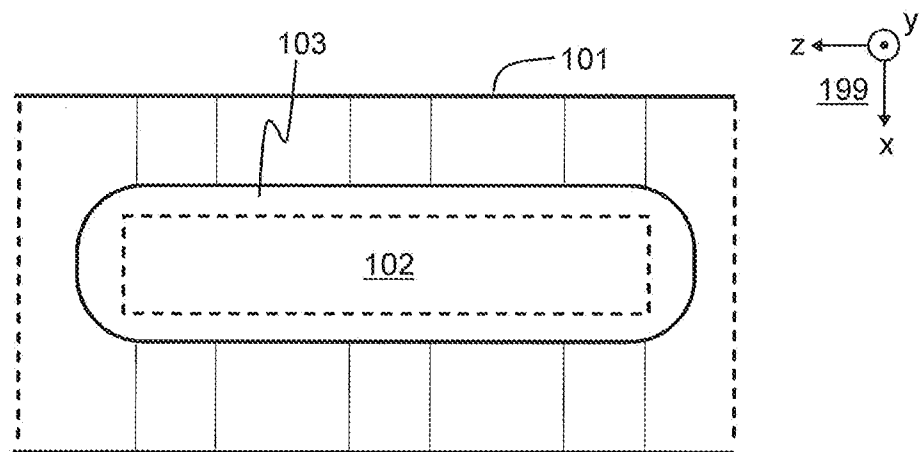

Figure 1b

2 / 6

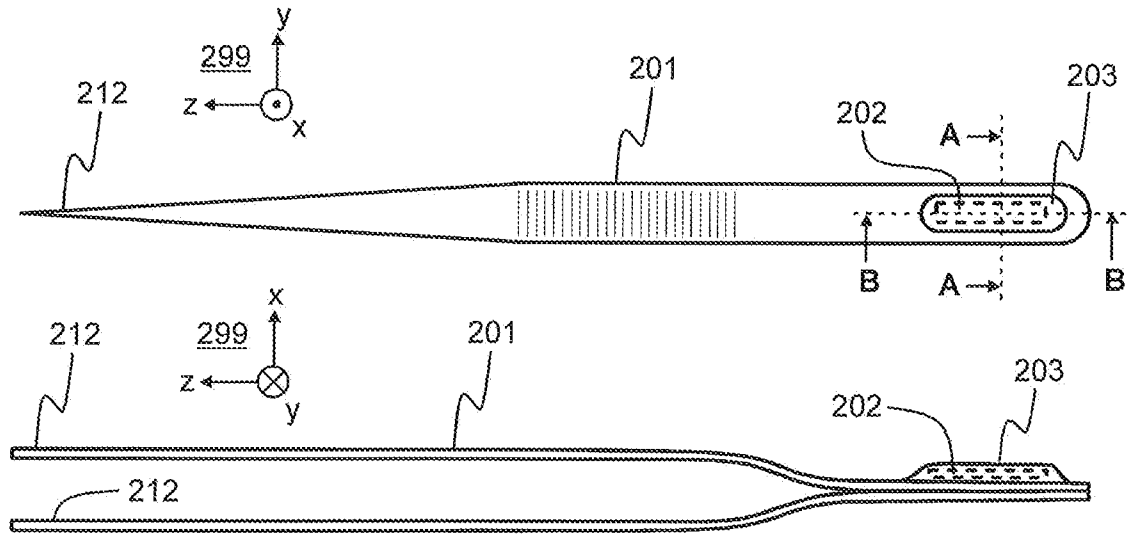

Figure 2a

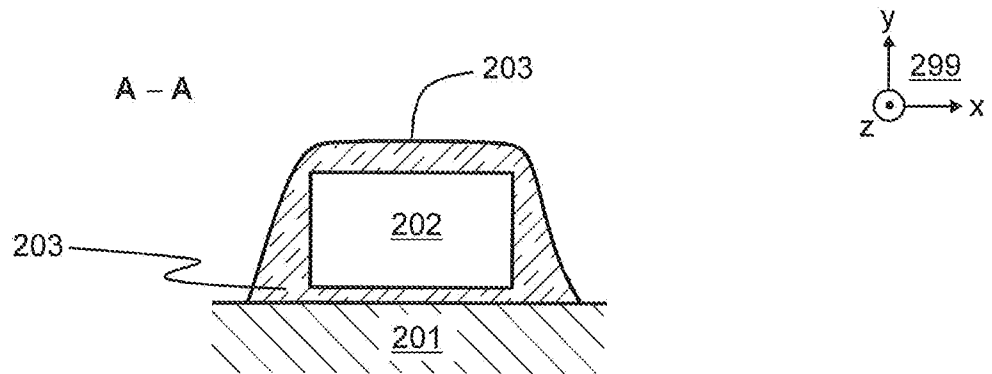

Figure 2b

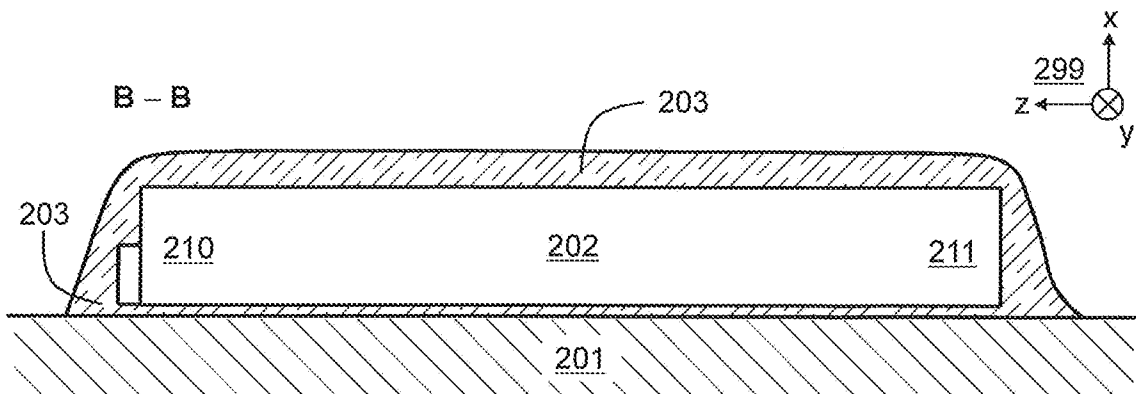

Figure 2c

3 / 6

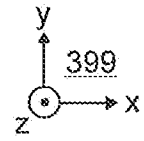
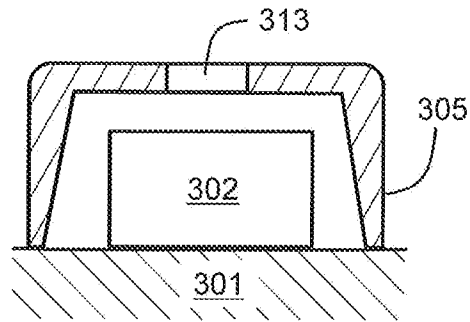

Figure 3a

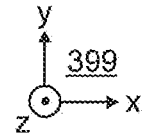
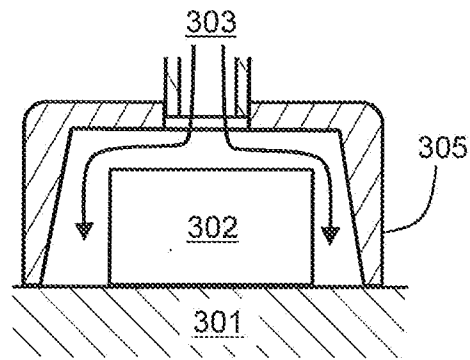

Figure 3b

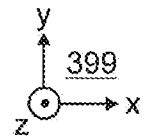
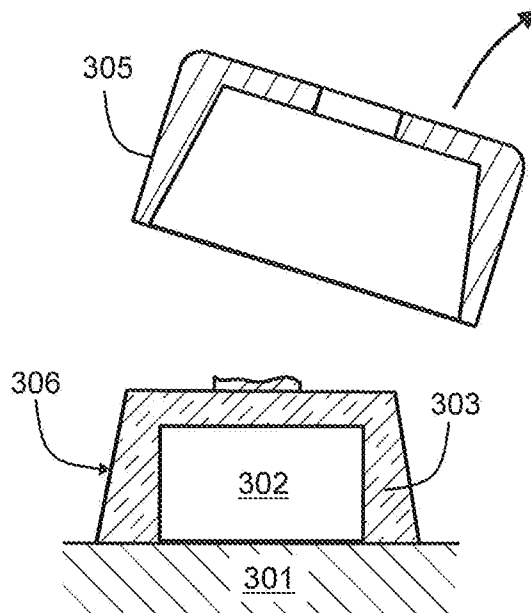

Figure 3c

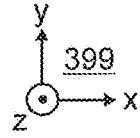
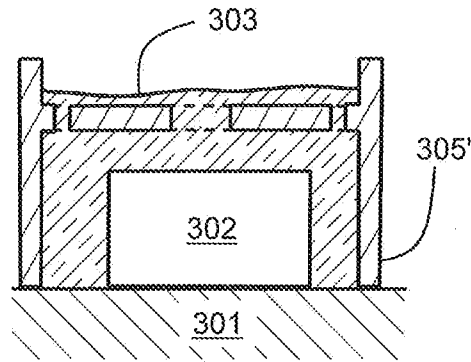

Figure 3d

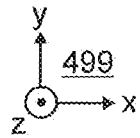
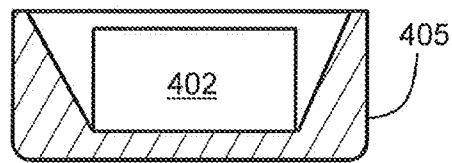

Figure 4a

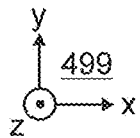
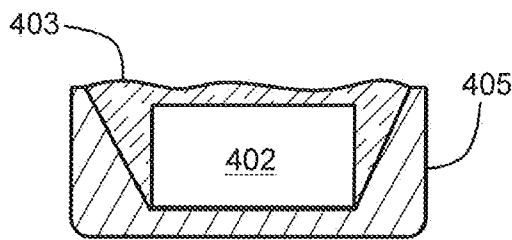

Figure 4b

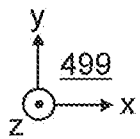
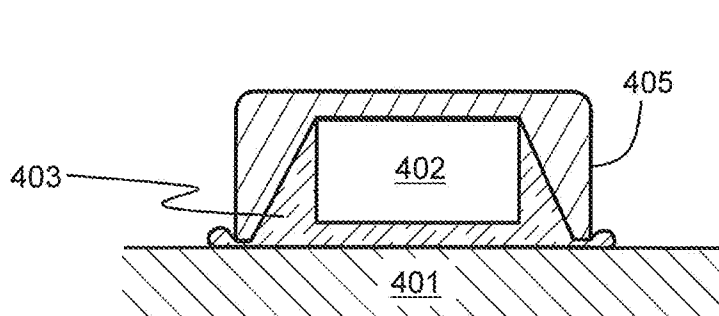

Figure 4c

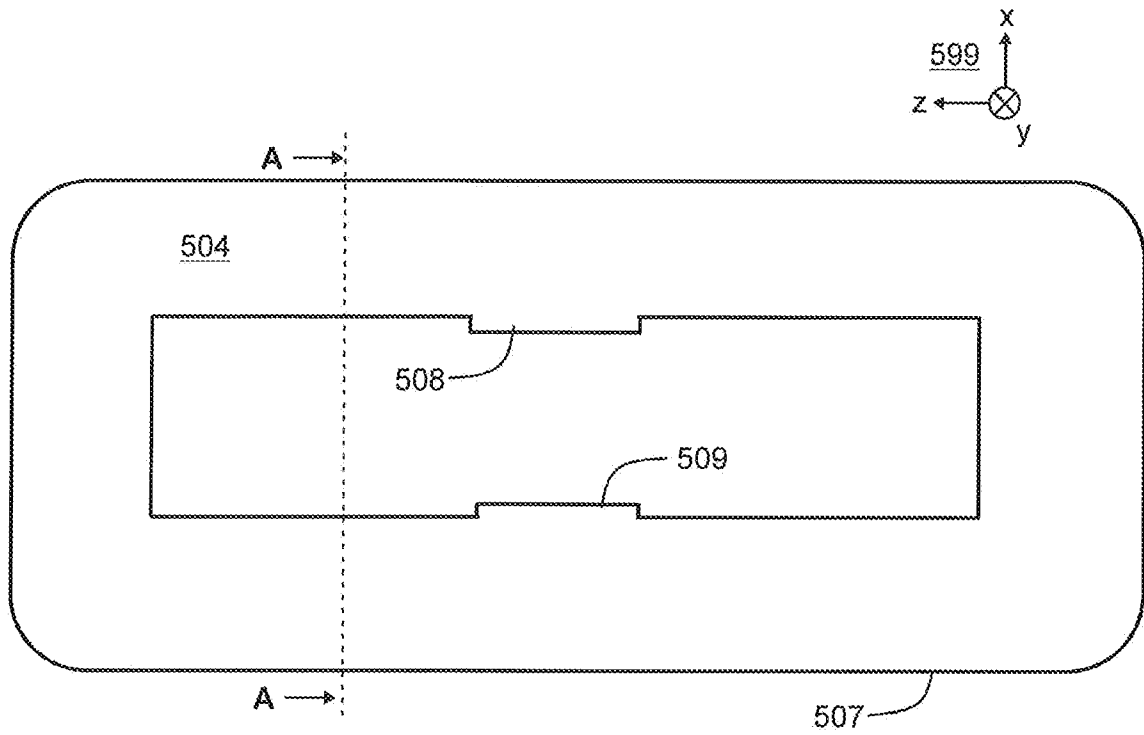

Figure 5a

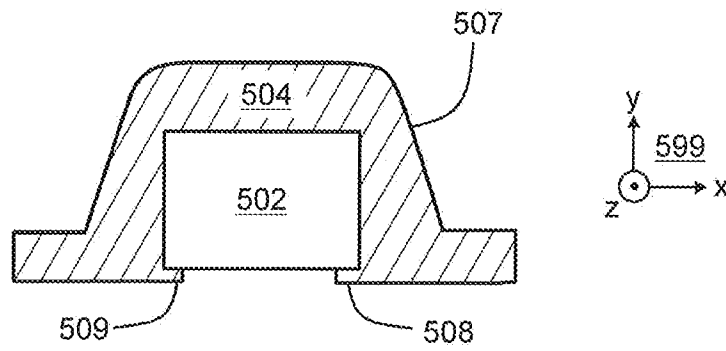

Figure 5b

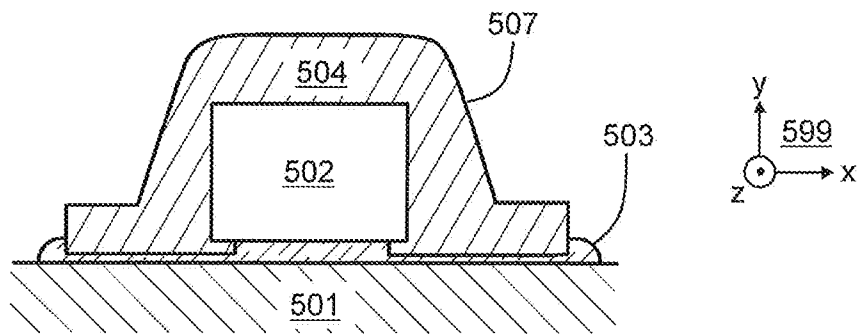

Figure 5c

INTERNATIONAL SEARCH REPORT

International application No.

PCT/FI2018/050196

A. CLASSIFICATION OF SUBJECT MATTER

See extra sheet

According to International Patent Classification (IPC) or to both national classification and IPC

B. FIELDS SEARCHED

Minimum documentation searched (classification system followed by classification symbols)

IPC: A61B, A61C, G06K

Documentation searched other than minimum documentation to the extent that such documents are included in the fields searched

FI, SE, NO, DK

Electronic data base consulted during the international search (name of data base, and, where practicable, search terms used)

EPODOC, EPO-Internal full-text databases, Full-text translation databases from Asian languages, WPIAP

C. DOCUMENTS CONSIDERED TO BE RELEVANT

Category*	Citation of document, with indication, where appropriate, of the relevant passages	Relevant to claim No.
X	US 2016296299 A1 (MORTENSEN SOREN BILSOE [DK]) 13 October 2016 (13.10.2016) paragraphs [0001], [0005], [0016], [0027], [0043], [0052], [0054-0055], [0069-0071], [0120], [0125], [0131-0132], [0134-0135], [0144]; claim 19; Figs. 6-7	1-7, 12-13, 18-22
X	US 2016128798 A1 (BOVET MARC [CH] et al.) 12 May 2016 (12.05.2016) paragraphs [0064], [0067]-[0069], [0071], [0075], [0097]; claims 1, 15, 16; Figures 1, 3, 6, 7	1, 8-12, 18
X	WO 2011054355 A2 (HEGEDUES VIKTOR [DE]) 12 May 2011 (12.05.2011) abstract; page 1: lines 10-15, page 4: line 33- page 5: line 2; Fig. 1	1, 12, 18

 Further documents are listed in the continuation of Box C.

 See patent family annex.

* Special categories of cited documents:	"T" later document published after the international filing date or priority date and not in conflict with the application but cited to understand the principle or theory underlying the invention
"A" document defining the general state of the art which is not considered to be of particular relevance	"X" document of particular relevance; the claimed invention cannot be considered novel or cannot be considered to involve an inventive step when the document is taken alone
"E" earlier application or patent but published on or after the international filing date	"Y" document of particular relevance; the claimed invention cannot be considered to involve an inventive step when the document is combined with one or more other such documents, such combination being obvious to a person skilled in the art
"L" document which may throw doubts on priority claim(s) or which is cited to establish the publication date of another citation or other special reason (as specified)	"&" document member of the same patent family
"O" document referring to an oral disclosure, use, exhibition or other means	
"P" document published prior to the international filing date but later than the priority date claimed	

Date of the actual completion of the international search

31 May 2018 (31.05.2018)

Date of mailing of the international search report

07 June 2018 (07.06.2018)

Name and mailing address of the ISA/FI
Finnish Patent and Registration Office
FI-00091 PRH, FINLAND

Facsimile No. +358 29 509 5328

Authorized officer
Kristina Björknäs

Telephone No. +358 29 509 5000

INTERNATIONAL SEARCH REPORT

International application No.

PCT/FI2018/050196

C (Continuation). DOCUMENTS CONSIDERED TO BE RELEVANT

Category*	Citation of document, with indication, where appropriate, of the relevant passages	Relevant to claim No.
X	WO 2016166284 A1 (CARETAG SURGICAL APS [DK]) 20 October 2016 (20.10.2016) page 1: lines 1-6, page 12: lines 14-28, page 16: lines 5-10; Figs. 1, 2	1, 12, 14-15, 18
X	WO 2011075433 A1 (CLEARCOUNT MEDICAL SOLUTIONS INC [US]) 23 June 2011 (23.06.2011) paragraphs [0030-0033], [0046-0047]; Figs. 1-2, 8-10	1, 16-18, 20, 23
X	WO 2007066204 A2 (GILLISPIE WILLIAM [CH]) 14 June 2007 (14.06.2007) paragraphs [0009], [0013], [0018], [0023], [0062], [0081], [0088], [00111]; claims 9, 20; Figs. 7 c-e	1, 16-18, 20, 23

INTERNATIONAL SEARCH REPORT
Information on Patent Family Members

International application No.
PCT/FI2018/050196

Patent document cited in search report	Publication date	Patent family members(s)	Publication date
US 2016296299 A1	13/10/2016	EP 3079624 A1 MX 2016007696 A WO 2015086775 A1	19/10/2016 09/12/2016 18/06/2015
US 2016128798 A1	12/05/2016	US 9592101 B2 CA 2886005 A1 CA 2886005 C CN 104837431 A CN 104837431 B DK 2757994 T3 EP 2757994 A1 EP 2757994 B1 ES 2535154 T3 JP 5801521 B1 JP 2015534182 A WO 2014045265 A1	14/03/2017 27/03/2014 11/04/2017 12/08/2015 02/01/2018 27/04/2015 30/07/2014 21/01/2015 05/05/2015 28/10/2015 26/11/2015 27/03/2014
WO 2011054355 A2	12/05/2011	None	
WO 2016166284 A1	20/10/2016	EP 3283000 A1 US 2018098822 A1	21/02/2018 12/04/2018
WO 2011075433 A1	23/06/2011	US 2011139877 A1	16/06/2011
WO 2007066204 A2	14/06/2007	None	

CLASSIFICATION OF SUBJECT MATTER

IPC
A61B 90/98 (2016.01)
A61B 90/90 (2016.01)
A61C 3/00 (2006.01)
G06K 7/10 (2006.01)