

(19) World Intellectual Property  
Organization  
International Bureau



(43) International Publication Date  
29 December 2004 (29.12.2004)

PCT

(10) International Publication Number  
**WO 2004/113777 A2**

(51) International Patent Classification<sup>7</sup>: **F16L**

(21) International Application Number:  
PCT/KR2004/001561

(22) International Filing Date: 26 June 2004 (26.06.2004)

(25) Filing Language: Korean

(26) Publication Language: English

(30) Priority Data:  
10-2003-0041877 26 June 2003 (26.06.2003) KR

(71) Applicant and

(72) Inventor: **PARK, Jong Seok** [KR/KR]; 204-206, the 2nd complex Sintri APT, 1258 Sinjeong-dong, Yangchon-gu, Seoul 158-070 (KR).

(74) Agent: **CHO, Sang Kyun**; 402 Daimyung Building 746-22, Yeoksam-dong, Kangnam-ku, Seoul 135-925 (KR).

(81) Designated States (*unless otherwise indicated, for every kind of national protection available*): AE, AG, AL, AM,

AT, AU, AZ, BA, BB, BG, BR, BW, BY, BZ, CA, CH, CN, CO, CR, CU, CZ, DE, DK, DM, DZ, EC, EE, EG, ES, FI, GB, GD, GE, GH, GM, HR, HU, ID, IL, IN, IS, JP, KE, KG, KP, KZ, LC, LK, LR, LS, LT, LU, LV, MA, MD, MG, MK, MN, MW, MX, MZ, NA, NI, NO, NZ, OM, PG, PH, PL, PT, RO, RU, SC, SD, SE, SG, SK, SL, SY, TJ, TM, TN, TR, TT, TZ, UA, UG, US, UZ, VC, VN, YU, ZA, ZM, ZW.

(84) Designated States (*unless otherwise indicated, for every kind of regional protection available*): ARIPO (BW, GH, GM, KE, LS, MW, MZ, NA, SD, SL, SZ, TZ, UG, ZM, ZW), Eurasian (AM, AZ, BY, KG, KZ, MD, RU, TJ, TM), European (AT, BE, BG, CH, CY, CZ, DE, DK, EE, ES, FI, FR, GB, GR, HU, IE, IT, LU, MC, NL, PL, PT, RO, SE, SI, SK, TR), OAPI (BF, BJ, CF, CG, CI, CM, GA, GN, GQ, GW, ML, MR, NE, SN, TD, TG).

**Published:**

— *without international search report and to be republished upon receipt of that report*

*For two-letter codes and other abbreviations, refer to the "Guidance Notes on Codes and Abbreviations" appearing at the beginning of each regular issue of the PCT Gazette.*

(54) Title: PIPE JOINT AND SNAP RING FOR THEREOF

(57) Abstract: The present invention relates to a pipe joint and a snap ring for the pipe joint. Hanging protrusions 32 include first bending portions 32a wherein the hanging protrusions 32 of the snap ring 30 are bent inwardly, and second bending portions 32b wherein the ends of the first bending portions 32a are bent in the spiral direction with it inclined at a given angle. If the second bending portions are adhered to the pipe 10 inserted into the pipe joint body 20, the pipe is not pulled out from the pipe joint body 20 by means of a single drawing force and can be separated from the pipe joint body according to a spiral principle in the second bending portion wherein the pipes are formed spirally by rotating the pipe.

WO 2004/113777 A2

PIPE JOINT AND SNAP RING FOR THEREOF

## Technical Field

The present invention relates to a pipe joint for connecting a  
5 plastic pipe for supplying hot water or city water for cold and heated  
room. More particularly, the present invention relates to a pipe  
joint that can be inserted in the one touch mode and be used without  
using additional tool, and allowing a pipe to be easily separated from  
a pipe joint body and repetitive separation and coupling.

10

## Background Art

A pipe joint, more particularly, an one touch pipe joint that  
can be coupled by pushing a pipe includes a snap ring. The snap ring  
is usually made of stainless steel. It has a ring shape so that it  
15 can be inserted into the pipe joint. A plurality of hanging  
protrusions that are disposed radially and bent in the direction where  
the pipe is inserted are formed within the ring.

Thus, if the pipe is inserted, the surface of the pipe bends the  
hanging protrusions of the snap ring inwardly. If the pipe is pulled,  
20 the hanging protrusions generate a wedge action to prevent the pipe  
from being pulled out. A packing for maintaining watertight between  
the pipe and the pipe joint is inserted within and outside the snap  
ring in the pipe joint.

Meanwhile, in the aforementioned conventional touch pipe joint, if the pipe is separated from the pipe joint, a cap be released from the pipe joint body when an additional screw type cap is provided, and the snap ring and the packing within the pipe joint is separated from the pipe. However, once the snap ring is inserted into the pipe, it cannot be separated. Thus, there is a problem that the pipe has to be cut. Furthermore, if an additional screw type cap is not provided and in case of a one touch pipe joint wherein both ends of the pipe joint are inner-bent, it is impossible to separate the pipe and the pipe joint without cutting the pipe.

In order to overcome the above problem, there was proposed an one touch pipe joint having a release hole for widening the snap ring from the outside. In case of a pipe joint having the release hole, a release hole and an assistant ring for preventing deviation of the release hole have to be inserted into the pipe joint additionally. Thus, there is a problem that manufacturing cost of a product increases. Furthermore, if the release hole is erroneously handled, there is problem that the pipe is taken off from the pipe joint.

## 20 Disclosure of Invention

Accordingly, the present invention has been made in view of the above problems, and it is an object of the present invention to provide a pipe joint wherein a pipe is inserted into the pipe joint by

pushing in the pipe without additional component except for a snap ring and a packing. Whereby watertight is possible and the pipe can be easily separated from the pipe joint, if needed.

To achieve the above objects, according to the present invention, there is provided a pipe joint having a pipe joint body into which a pipe is inserted, a snap ring disposed within the body wherein hanging protrusion that engage the pipe, and a packing for maintaining watertight between the pipe and the body, hanging protrusions of the snap ring, wherein the protrusions include first bending portions that are bent toward the inside of the body, and second bending portions that are extended from the first bending portions wherein the front ends of the second bending portions are bent in the spiral direction with it inclined at a given angle.

## 15 Brief Description of Drawings

Further objects and advantages of the invention can be more fully understood from the following detailed description taken in conjunction with the accompanying drawings in which:

Fig. 1 is a dismantled perspective view of a pipe joint according to an embodiment of the present invention;

Fig. 2 is a coupled cross-sectional view of the pipe joint shown in Fig. 1;

Fig. 3 shows a state where a pipe is inserted into the pipe

joint according to the present invention;

Fig. 4 is a perspective view of a snap ring disposed within the pipe joint according to the present invention;

Fig. 5 is a cross-sectional view of the snap ring shown in Fig. 4;

Fig. 6 shows a state where the pipe is separated from the pipe joint while the pipe is turned; and

Fig. 7 is a cross-sectional view of a pipe joint according to another embodiment of the present invention.

10

#### Best Mode for Carrying Out the Invention

The present invention will now be described in detail in connection with preferred embodiments with reference to the accompanying drawings.

15 A pipe joint according to the present invention may have a straight shape, an elbow shape, a T shape and a crisscross shape. Only the pipe joint of the straight type will be described in the following embodiment.

20 In the pipe joint, an insertion location of a snap ring and a packing may be different. In the present invention, the snap ring is disposed within the packing in order to maintain watertight at the outside. The snap ring is disposed outside the packing in order to maintain watertight at the inside. A material of a pipe joint body

may be a metal (brass), synthetic resin or the like depending on the use of the pipe joint, i.e., the use of pipe arrangement.

In the pipe joint, after the snap ring and the packing are inserted into the pipe joint body, the inlet portion is fabricated to be a non-separating type that is inner-bent by a forging process, as in an embodiment of Fig. 1 to Fig. 5. Also, the inlet portion is fabricated to be a screw type cap as in an embodiment to be described later. By replacing an existing one touch pipe joint with only the snap ring of the present invention, the same function and effect as the present invention can be obtained.

Fig. 1 is a dismantled perspective view of a pipe joint according to an embodiment of the present invention. Fig. 2 is a coupled cross-sectional view of the pipe joint shown in Fig. 1. Fig. 3 shows a state where a pipe is inserted into the pipe joint according to the present invention. Fig. 4 is a perspective view of a snap ring disposed within the pipe joint according to the present invention. Fig. 5 is a cross-sectional view of the snap ring shown in Fig. 4.

Referring to Figs. 1 to 5, the pipe joint according to the present invention includes a pipe joint body 20 into which a pipe 10 is inserted, a snap ring 30 disposed within the body 20 wherein hanging protrusions 32 that engage the pipe 10, and a packing 40 for maintaining watertight between the pipe 10 and the body 20. In the above, hanging protrusions 32 of the snap ring 30 include first

bending portions 32a that are bent toward the inside of the body 20, and second bending portions 32b that are extended from the first bending portions 32a wherein the front ends of the second bending portions 32b are bent in the spiral direction with it inclined at a  
5 given angle.

In an embodiment, the pipe joint may include the pipe joint body 20, the snap ring 30, the packing 40, the snap ring 30 and the assistant ring 50 for preventing fluctuation. In this case, additional components need not to be added compared to an existing one  
10 touch pipe joint. Thus, there are no problems such as increased manufacturing cost and difficulty of production. Only the shape of the snap ring 30 is bent differently. It is thus possible to insert the pipe by pressing and to easily separate the pipe from the pipe joint, if necessary. Therefore, the effectiveness is high in actual  
15 use.

The snap ring will not be described in detail. As shown in Figs. 4 and 5, the hanging protrusions 32 are formed radially in plural within the snap ring 30. All of the hanging protrusions 32 have the first bending portions 32a that are firstly bent toward the inside of  
20 the pipe joint body 20. The second bending portions 32b that are inclined at a given angle in the spiral direction against a virtual axis that passes through the center of the snap ring 30 are formed at the ends of the first bending portions 32a. Thus, the front end

portions 32c of the second bending portions 32b face the outer circumference of the pipe 10. The snap ring 30 has a plate shape such as stainless steel. A circular circumference of the snap ring 30, the first bending portions 32a, the second bending portions 32b, and the front end portions 32c of the second bending portions 32b generate a tension action that shrinks inwardly, thus fastening the exterior of the pipe 10.

In the present invention, it is preferred that a pitch angle of the front end portions 32c of the second bending portions 32b is about 30° .

Accordingly, the pipe 10 is closely adhered to the front end portions 32c of the second bending portions 32b of the snap ring 30. Thus, the pipe can be easily inserted into the pipe joint if a tilt angle of the first bending portions 32a is widened outwardly. Also, if the pipe is pulled outwardly from the pipe joint, a wedge action occurs as the hanging protrusions 32 gathers together by means of the tilt angle inclined toward the inside of the first bending portions 32a, preventing the pipe from being deviated.

Meanwhile, if the snap ring 30 is inserted into the pipe joint body 20 and is to be separated by rotating the pipe 10, a concave or convex anti-rotational element 34 for preventing the snap ring 30 from rotating together with the pipe is formed outside the snap ring 30. A convex or concave anti-rotational element 24 that receives the anti-

rotational element 34 or that will be received in the anti-rotational element is also formed within the pipe joint body 20.

In the snap ring of the present invention, in case where the pipe is to be pulled out from the pipe joint, if the pipe is rotated in one direction along the spiral direction of the second bending portions 32b, the front end portions 32c of the second bending portions 32b of the hanging protrusions 32 that touches the surface of the pipe serve as the crest of a fixed thread. Therefore, the pipe 10 is pulled out as it forms some spiral grooves (scratch mark) on the pipe in the spiral direction.

Fig. 6 shows a state where the pipe is separated from the pipe joint while the pipe is turned.

Referring to Fig. 6, if the pipe 10 is rotated in one direction (in the anti-clockwise direction in the drawing), the pipe 10 moves back against the pipe joint body 20 as spiral grooves are formed in the pipe 10, against a tilt angle (pitch angle) formed by the front end portions 32c of the second bending portions 32b of the snap ring 30 that is inserted into the pipe joint body 20. As a result, the pipe 10 is pulled out from the pipe joint body 20. It is possible to control the speed that the pipe 10 is pulled out from the pipe joint body 20 by means of rotation of the pipe 10 depending on the tilt angle formed by the front end portions 32c of the second bending portions 32b of the snap ring 30.

Even if pressure occurs within the pipe, a rotary force is not generated in the pipe itself. Thus, the pipe coupled to the pipe joint body is not separated. It is thus possible to maintain a stable pipe laying state. If pipe arrangement is to be replaced, the pipe  
5 can be separated from the pipe joint body by rotating the pipe against the pipe joint body using the hands or a pipe wrench. A snap ring and a packing within the pipe joint body are not deformed. Therefore, the pipe joint can be used repeatedly by inserting a new pipe.

Fig. 7 is a cross-sectional view of a pipe joint according to  
10 another embodiment of the present invention. Referring to Fig. 7, the snap ring 30 according to the present invention is provided in a known separating pipe joint body 20 having a screw cap 22. Thus, the pipe can be separated from the pipe joint body in a rotary mode.

## 15 Industrial Applicability

According to the present invention, hanging protrusions of a snap ring disposed within an one touch pipe joint includes first bending portions inclined toward the inside of a pipe joint body and second bending portions having a tilt angle. Thus, if a pipe is  
20 connected to the pipe joint body, it can be inserted into the pipe joint body by pushing the pipe in. Also, in case where the pipe is separated from the pipe joint, if the pipe is rotated in one direction, the pipe and the second bending portion of the snap ring are separated

according to the screw principle. Thus, the pipe can be easily separated from the pipe joint. Therefore, the present invention has an effect that a pipe can be easily replaced since a pipe can be easily separated from an one touch pipe joint without an additional  
5 component.

## What Is Claimed Is:

1. A pipe joint having a pipe joint body 20 into which a pipe 10 is inserted, a snap ring 30 disposed within the body wherein hanging protrusion that engage the pipe, and a packing 40 for maintaining watertight between the pipe and the body, comprising:

hanging protrusions 32 of the snap ring, wherein the protrusions include first bending portions 32a that are bent toward the inside of the body 20, and second bending portions 32b that are extended from the first bending portions 32a wherein the front ends of the second bending portions 32b are bent in the spiral direction with it inclined at a given angle.

2. The pipe joint as claimed in claim 1, further comprising an anti-rotational element 34 for preventing the snap ring 30 from being rotated by means of rotation of the pipe 10 outside the snap ring 30.

3. The pipe joint as claimed in claim 1, wherein a pitch angle of the front end portions 32c of the second bending portions 32b is about 30° .

4. The pipe joint as claimed in claim 1, wherein the pipe joint body 20 has a detachable screw cap 22.

5. The pipe joint as claimed in claim 1, wherein the pipe joint body 20 is a non-separating type whose inlet is inner-bent.

6. A snap ring inserted into a pipe joint wherein hanging protrusions 32 for engaging a pipe,

wherein the hanging protrusions 32 include first bending portions 32a that are bent toward the inside of the body 20, and second bending portions 32b that are extended from the first bending portions 32a wherein the front ends of the second bending portions 32b are bent in the spiral direction with it inclined at a given angle.

7. The pipe joint as claimed in claim 6, further comprising an anti-rotational element 34 for preventing the snap ring 30 from being rotated by means of rotation of the pipe 10 outside the snap ring 30.

15

8. The pipe joint as claimed in claim 6 or 7, wherein the snap ring has a steel plate shape that serves as a tension action wherein a circular edge of the snap ring, the first bending portions 32a, the second bending portions 32b and front end portions 32c integrally inwardly shrink.

20



FIG 2

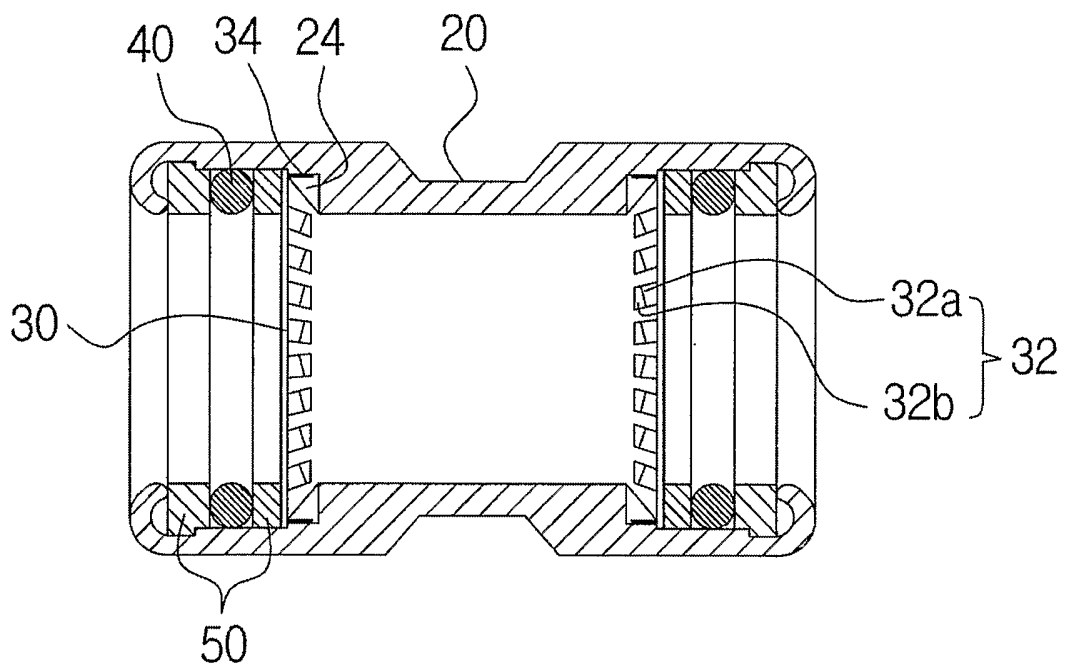

FIG 3

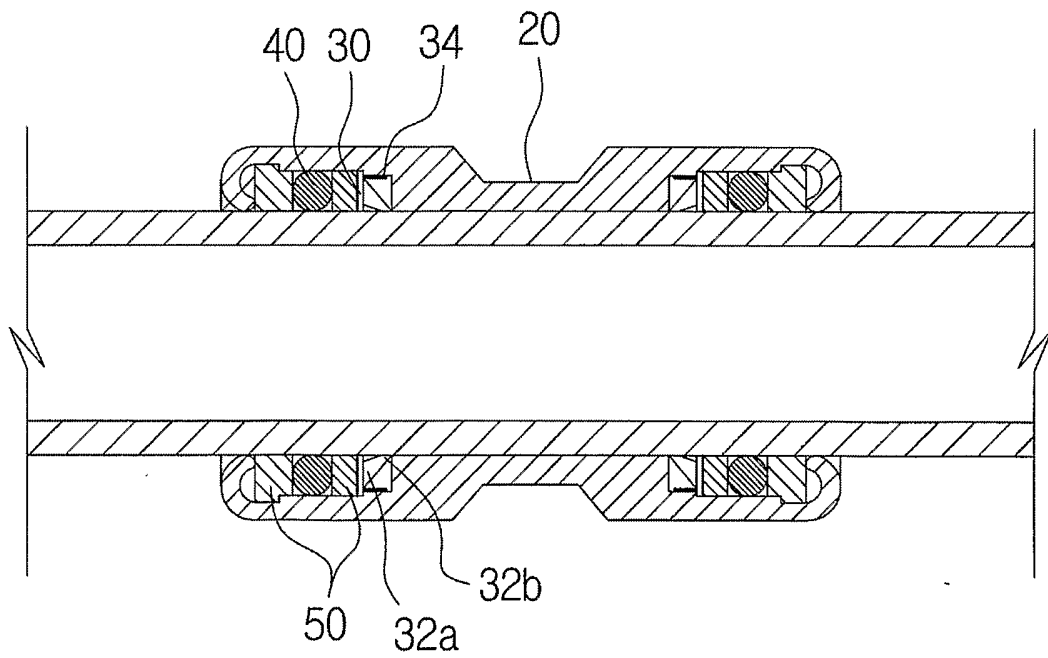

FIG 4

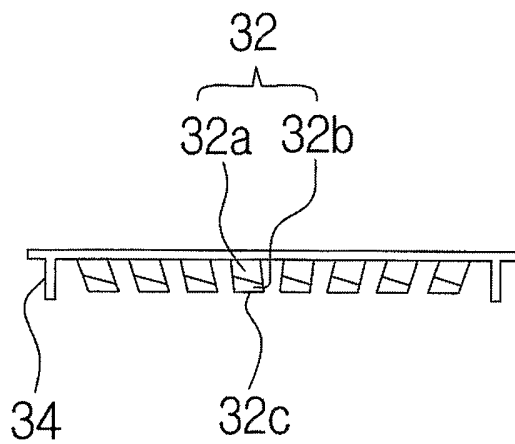

FIG 5

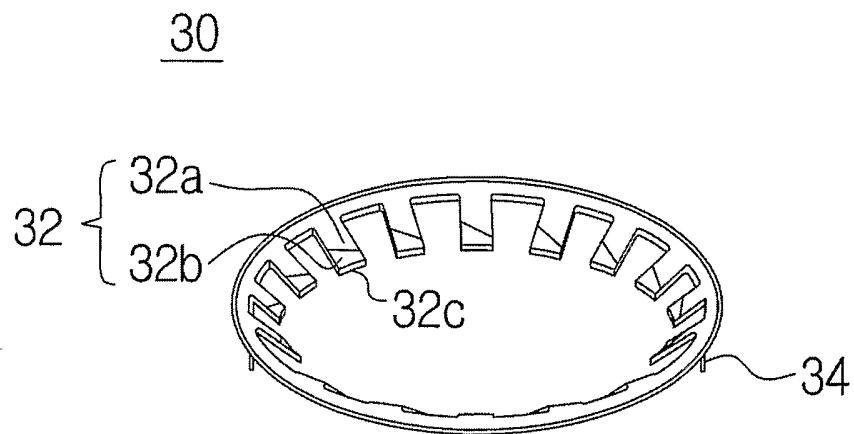

FIG 6

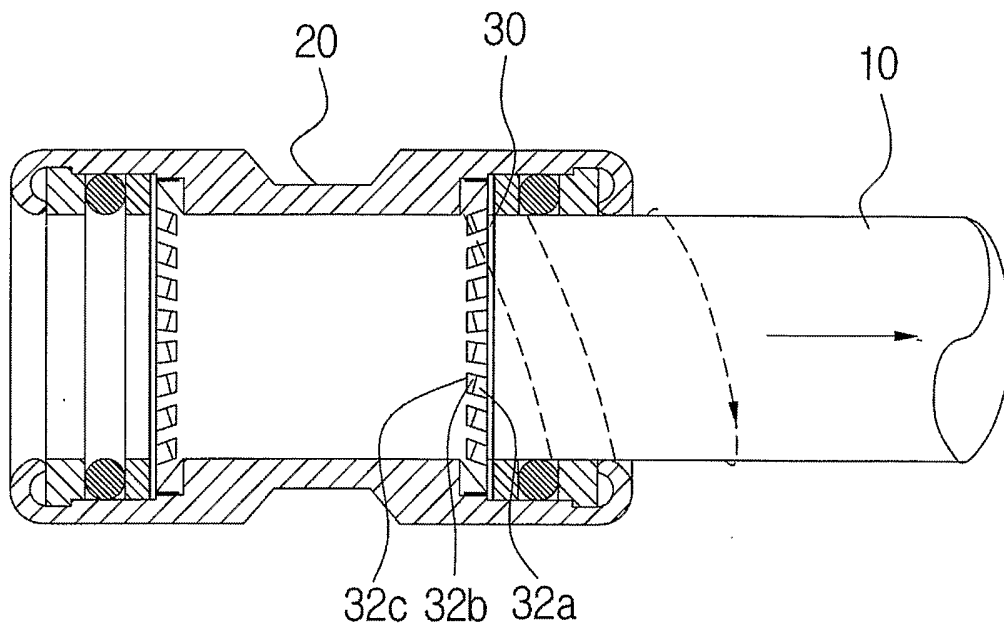

FIG 7

