

(No Model.)

3 Sheets—Sheet 1.

J. R. WILSON.
DUMPING APPARATUS.

No. 475,049.

Patented May 17, 1892.

FIG. 1.

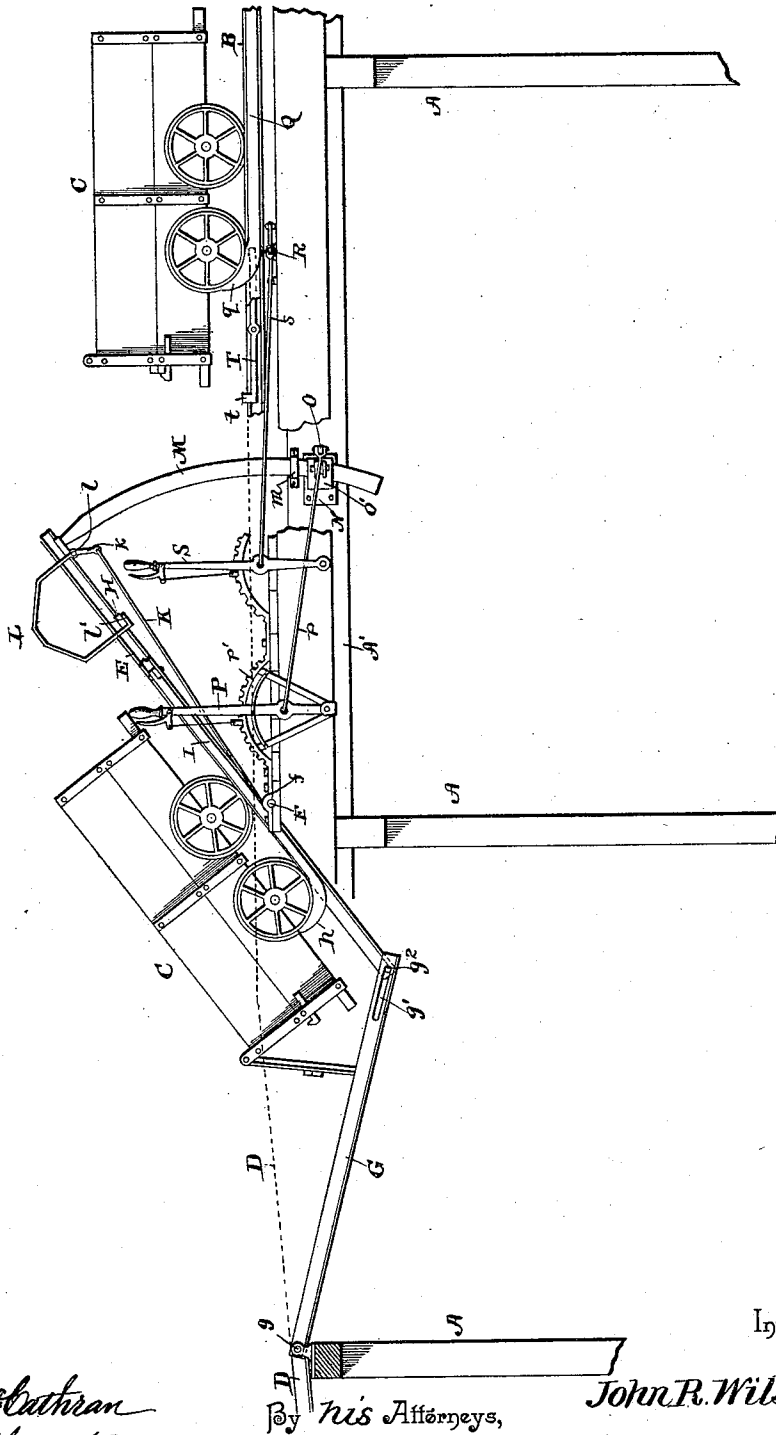

Witnesses

Jas. K. McArthur
D. P. Haupt

Inventor

John R. Wilson

By *his Attorneys,*

C. Snow & Co.

(No Model.)

3 Sheets—Sheet 2.

J. R. WILSON.
DUMPING APPARATUS.

No. 475,049.

Patented May 17, 1892.

FIG. 2.

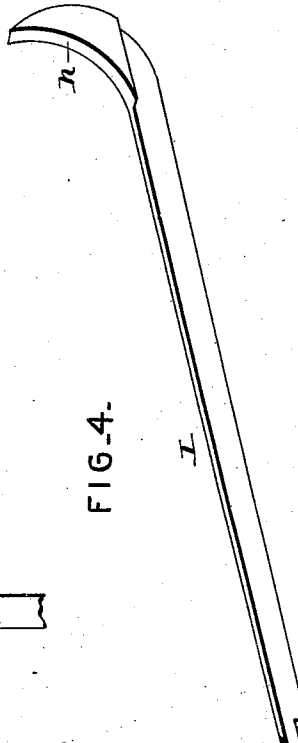
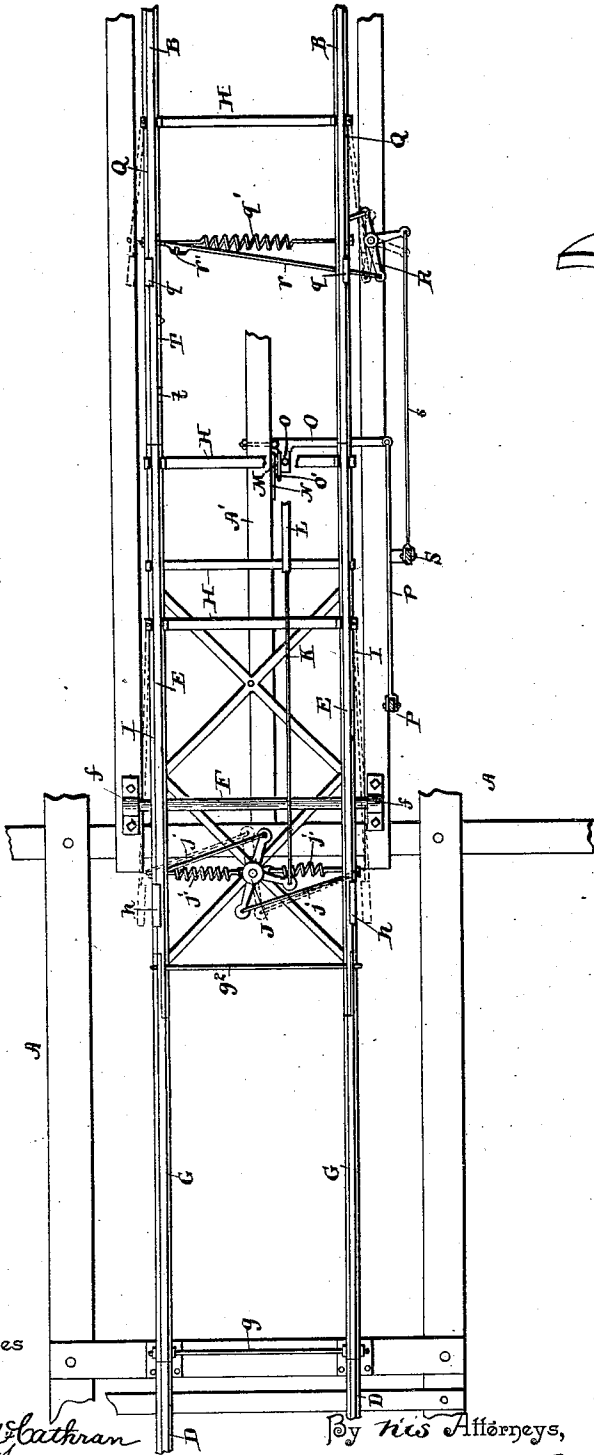

FIG. 4.

Witnesses

Jas. K. McEachran
D. P. Ashbaugh

By *his* Attorneys,

Inventor

John R. Wilson

C. Snow & Co.

(No Model.)

3 Sheets—Sheet 3.

J. R. WILSON.
DUMPING APPARATUS.

No. 475,049.

Patented May 17, 1892.

FIG. 3.

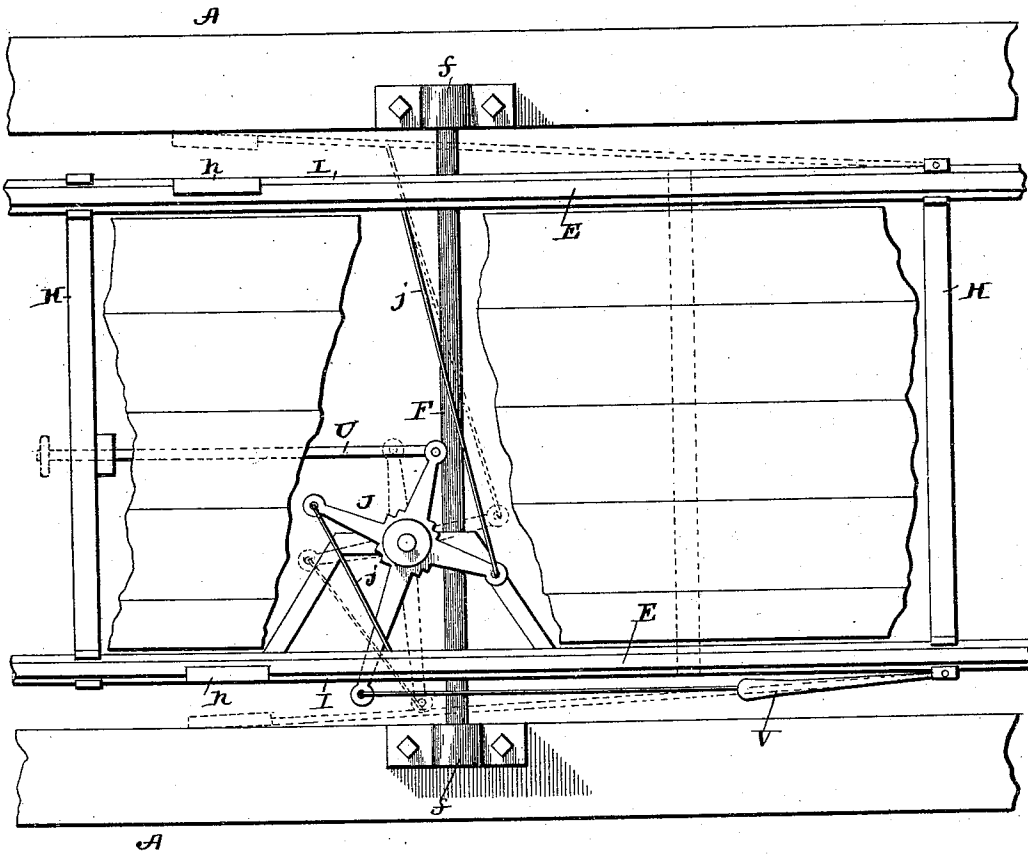
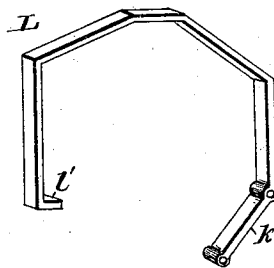

FIG. 5.



Witnesses

James K. McLaughlin
D. P. Hulshof

Inventor

John R. Wilson

By his Attorneys,

C. A. Snow & Co.

UNITED STATES PATENT OFFICE.

JOHN R. WILSON, OF PITTSBURG, PENNSYLVANIA, ASSIGNOR OF ONE-HALF
TO NATHAN P. HYNDMAN, OF SAME PLACE.

DUMPING APPARATUS.

SPECIFICATION forming part of Letters Patent No. 475,049, dated May 17, 1892.

Application filed January 9, 1892. Serial No. 417,540. (No model.)

To all whom it may concern:

Be it known that I, JOHN R. WILSON, a citizen of the United States, residing at Pittsburg, in the county of Allegheny and State of Pennsylvania, have invented a new and useful Automatic Dumping Apparatus, of which

the following is a specification.

This invention relates to dumping apparatus; and it has for its object to provide an automatic dumping apparatus for automatically dumping ore and coal or other material through floors or the ordinary trestle-work supporting the tracks which will be particularly efficient in its work, while at the same time the dumping apparatus will be simple in construction and easy of manipulation.

The primary object of the invention is to provide an apparatus which will provide for the automatic releasing of the emptied car or wagon at the same time that the loaded car or wagon is traveling to the point at which it will be automatically dumped, and to this end to provide such an apparatus as is set forth by this specification.

With these and many other objects in view, which will readily appear as the nature of the invention is fully understood, the same consists in the novel construction, combination, and arrangement of parts hereinafter more fully described, illustrated, and claimed.

In the accompanying drawings, Figure 1 is a side elevation, partly in section, of a dumping apparatus constructed in accordance with my invention, illustrating one car dumping and the loaded car checked upon the main portion of the track. Fig. 2 is a top plan view of the same. Fig. 3 is a detail plan view of a section of a track provided with a dumping device constructed in accordance with a modification when one or more dumps are required on the same track at the same point of operation. Fig. 4 is a detail in perspective of one of the stop-horns. Fig. 5 is a similar view of the press-lever.

Referring to the accompanying drawings, A represents the upper portion of a trestle-supported frame, to the top of which is secured the rails B, forming a track upon which the dumping cars or wagons C are adapted to travel and be automatically dumped at the

point of dumping in the line of the track, and from which point after said cars or wagons are dumped the same travel down the inclined portion D of the track to be refilled in the ordinary manner.

The tilting rails E form a continuation of the main rails B of the main portion of the track and are mounted upon or connected with the transverse axle or shaft F, journaled in the boxes *f*, located near the end of the frame timbers at the point where the cars C are to be dumped, and said tilting rails are connected with said axle or shaft at any given position to suit the various lengths and constructions of the dumping wagons or trucks, so that the same when filled will tilt the rails until dumped, and when emptied or partly emptied, as desired, will cause said rails to resume their normal positions in a line with the rails forming the main body of the track.

Forming a portion of the inclined track D are the hinged or pivoted rails G, pivotally mounted upon the rods *g*, located directly in front of the ends of the inclined rails, and said swinging rails G are halved onto the dropping ends of the rails E, and are provided at said ends with the longitudinally-disposed slots *g'*, in which are designed to work the projecting ends of the cross-rod *g²*, connecting the ends of the tilting rails E and extending to either side of the same. The connection between the hinged and tilting rails allows the connecting ends of the same when the loaded wagon or truck tilts the tilting rails to drop downward through the portion of the frame-work at which the dump is located, and thus allows for the different positions that the said rails must assume when the same are thrown down and up, respectively, and when their normal positions provide for a continuous track over and down which the emptied or partly emptied truck travels.

A series of bridles H brace the tilting rails E apart, and are also adapted to carry the devices and mechanism used in connection therewith. To the outer projecting ends of one of the intermediate bridles H are pivoted the ends of the opposite stop and releasing horns I, extending longitudinally of said rails and

provided with upturned ends *h*, projecting above the top of said rails and normally fitting close thereto, in order to engage the tread of the forward wheels of the truck upon said tilting rails, and the curved or stop ends of said horns are so disposed with relation to the tilting portion of the track that the weight of the truck is sufficient to tilt the track and thus dump the contents thereof through the supporting-frame or through the floor, as the case may be, which supports said track, and when said truck has discharged or partly discharged the contents thereof the track will resume its normal position and the truck will be released in the manner to be described.

Horizontally and centrally pivoted to the connecting-braces at the dumping end of the tilting portion of the track is the horizontal T-shaped lever *J*, to the opposite ends of the head of which are pivotally secured the opposite horn-controlling rods *j*, also connected to the opposite horns *I*, located upon the outside of the opposite rails *E*, comprising said tilting portion of the track. Opposite retractile springs *j'* are secured to the intermediate bridle and to the hook or stop ends of said horns, so that after the rods *j* have forced said horns outward and out of the path of the rails of the track the said springs will withdraw said horns back and in contact with the sides of the rails, in order to catch and hold the next succeeding car or wagon to be dumped. An operating-rod *K* is pivotally connected to the outer end of the stem or arm of said T-shaped lever, and extending longitudinally of the tilting portion of track is connected to the depending arm *h*, projecting below the point or pivot and operated by the upwardly-extending press-lever *L*. The said press-lever *L* is pivoted at *l* to one of the braces *H* at one end of the tilting rails and between the same, and said press-lever extends above the plane of the track and is provided at its free or swinging end with a stop-flange *l'*, that is designed to work beneath one of the connecting-braces *H*, and thus form a stop for said press-lever when the same assumes its normal position, extended above the plane of the tilted track. It can be readily seen now that after the truck held upon the tilting track by the horns connected therewith has been dumped of its contents the tilting and hinged track sections will resume their normal positions in a line with the main portion of the track. The tilting track having assumed its position in line with the main portion of the track, the next loaded car or truck is allowed to roll thereon. Immediately upon striking the tilting section of the track the low body of the truck strikes the upwardly-extending press-lever *L*, which passes beneath the bottom of said loaded car. Motion is at once communicated through the press-lever rod *K* to the oscillating T-lever *J*, which throws the opposite arm *j* outwardly beyond the rails *E* and causes the stop or hook ends *h* of the opposite horns to spread and be thrown out of contact with the

tread of the forward wheels of the emptied or partly emptied car or truck. The emptied car or truck being released immediately travels down the track to the point of connection with a return side track, so that the car may re-enter the mine. The loaded truck by this time has passed over the elevated press-lever *L*, and the opposite horns are then free to be withdrawn against the sides of the rails under the tension of the retractile withdrawing-springs *j'*, and this being done or effected automatically before the forward wheels of the loaded car reach the ends of the horns, the same are ready to check and hold the said car, while the same automatically tilts the track and discharges its contents in the manner just described. A curved friction-bar *M* is secured to the rail-brace *H* adjacent to said press-lever, and is steadied by and works through the guide-plate *m*, secured to one of the central longitudinal timbers comprising the track-frame. Directly below said guide-plate *m* and to said timber, which may be designated as *A'*, is secured the stationary brake-plate *N*, over the face of which one side of the flat curved bar *M* works. Pivoted at its inner end to said timber *N'* is the horizontal brake-lever *O*, provided with an arm *o*, carrying a flat brake-shoe *o'*, pivoted to said arm and parallel with the stationary brake-plate *M*. As said lever is operated the brake-shoe *o'* can be clamped upon the friction-bar *M* as tightly as desired, and thus prevents the tilting section of the track from tilting too suddenly or abruptly or to return to its normal position with too great a jar. The outer end of the brake-lever *O* extends to one side of the track and is connected with the hand operating-lever *P* by means of the connecting-rod *p*. The said hand-lever *P* is pivotally mounted upon the adjacent frame-work and works between and is regulated by the ordinary lever-segments *p'*. While the car or truck upon the tilting section of the track is discharging its contents the next succeeding loaded car is held in check, awaiting its turn by the supplemental safety check-horns *Q*, pivotally secured to opposite sides of the main portion of the track in rear of said tilting portions. The said horns are also provided with the hook or stop ends *q* and are connected together by the single intermediate retractile spring *q'*, connecting said horns together, so that the same may be normally held in contact with the rails or drawn to the same after being released from their outspread positions.

Pivoted upon one side of the main portion of the track and to the supporting-timbers is a supplemental T-shaped lever *R*, to the opposite ends of the head of which are pivotally secured the opposite spreading-rods *r*, connected with the opposite safety-horns *q*, which when said T-lever *R* is operated will be spread outward from the track and allow the loaded car to pass upon the tilting track when the car in front of the same has been dumped or partly dumped of its contents. The outer end

of the operating arm or stem of the lever R is connected with the hand operating-lever S by means of the connecting-rod s, and is controlled by the operator in the same manner as the hand-lever P, secured to the track-supporting frame to one side thereof. One of the spreading-rods *r* is provided with a locking-notch *r'*, which when the horns are spread is designed to receive the inner end of the latch T, pivoted to the inside of one of the rails B of the main portion of the track and which serves to hold the horns apart until the loaded truck has passed beyond the same. The other end of the pivoted latch is provided with an upwardly-extending strike-lug *t*, which when the rear wheels of the loaded wagon have passed beyond the horns is designed to be pressed down by the flange of the front wheel. The latch is of course immediately lifted out of the notch *r'* and allows the horns to close and be ready to check the approaching car. The operation of dumping and checking the loaded wagons is repeated and automatically controlled in the manner herein described.

When it is designed to have one or more dumps in a single line of tracks—that is, to partly dump the contents of one car at one point and then dump again at another—I provide a modification of the herein-described apparatus, as illustrated in Fig. 3 of the drawings. This figure illustrates the track as supported upon a solid floor, through which the contents of the cars or trucks are dumped. In this modification the T-shaped lever J is modified to form a cross-shaped lever, to the extreme upper end of which is pivotally secured a longitudinal siding locking-bolt U, which by the same motion of the lever J that spread the horns I is thrown into a suitable keeper in the frame or flooring, which thus holds the dump in a rigid position, so as to carry any weight that may pass thereover. It will be observed that when the horns are closed the bolt is withdrawn, thereby allowing the next succeeding truck to dump. The controlling of the horns and locking-bolt is by means of the press-lever V, corresponding to the press-lever F, and may be of the same construction, but, as illustrated, is disposed to one side of the tilting track, in order to insure a ready operation of the modified form of apparatus.

The construction, operation, and advantages of the dumping apparatus are now thought to be apparent without further description.

In regard to the brake herein described it may be additionally noted at this point that the same may not only be used for the purposes set forth, but may be also used to regulate the motion of the dump and hold the same at any degree or pitch to allow the contents of the car or truck to pass out quickly or moderately, as desired.

Having thus described my invention, what I claim, and desire to secure by Letters Patent, is—

1. In a dumping apparatus, the combination of a tilting-track section, a supplemental dropping-track section pivotally connected at its dropping end directly with said tilting track and adapted to form a continuation thereof when both sections are aligned, and means for holding the truck upon, and means for automatically releasing the same from, said tilting track, substantially as set forth.

2. In a dumping apparatus, a tilting-track section, a supplemental drop-track section pivoted at one end to the main track and provided at the other dropping end with longitudinally-disposed slots formed in the rails thereof, a coupling-rod projecting beyond the sides of the rails of said tilting-track portion and engaging said slot in the rails of said drop-track to directly pivot the same thereto, and means for holding the truck upon, and means for automatically releasing the same from, said tilting track, substantially as set forth.

3. In a dumping apparatus, a tilting-track section, longitudinally-disposed horn-stops pivoted to the sides of said track, a spreading-lever pivoted to said track-section and connected with the ends of the opposite stops, and an elevated press-lever pivoted between the rails of said track-section near one end thereof and connected with said spreading-lever, said press-lever projecting normally above the plane of the track-section and provided at its free or swinging end with a flange-stop engaging said track-section, substantially as set forth.

4. In a dumping apparatus, a tilting-track section, means for holding the truck upon and automatically releasing the same from said track-section, a curved flat depending friction-bar secured to one end of said track-section and working in a guide secured to the bed or frame supporting the track, a stationary brake-plate beneath the bar-guide, a brake-lever pivoted at one end centrally between the rails and provided with a projecting arm near said end, a brake-shoe pivotally connected to said lever-arm parallel with the stationary brake-plate, over which works said bar, and an operating-lever connected with said brake-lever, substantially as set forth.

5. In a dumping apparatus, the combination, with the main and tilting track sections, of opposite horn-stops pivotally secured to the sides of the main track, a T-lever located adjacent to said main-track portion, spreading-rods connected to opposite ends of said levers and the opposite ends of said horn-stops, one of said spreading-rods being provided with a locking-notch, a controlling or operating lever connected with said T-lever, a horizontal latch pivoted to one of the rails and adapted to engage said locking-notch, and a closing-spring connecting the ends of said horn-stops to close the same against the rails after the disengagement of said latch from said notch, substantially as set forth.

6. In a dumping apparatus, the combination, with the main track, of a tilting-track

section, opposite horn-stops pivotally connected with the opposite sides of said tilting section, a spreading and locking cross-lever, spreading-rods connected to opposite arms of the cross-lever and said horn-stops, a sliding locking-bolt pivotally connected to the end of one of the arms of said lever and adapted to be thrown into and out of a suitable adjacent support, and means for automatically

controlling said lever, substantially as set forth.

In testimony that I claim the foregoing as my own I have hereto affixed my signature in the presence of two witnesses.

JOHN R. WILSON.

Witnesses:

N. P. HYNDMAN,

W. M. DALGLIESH.