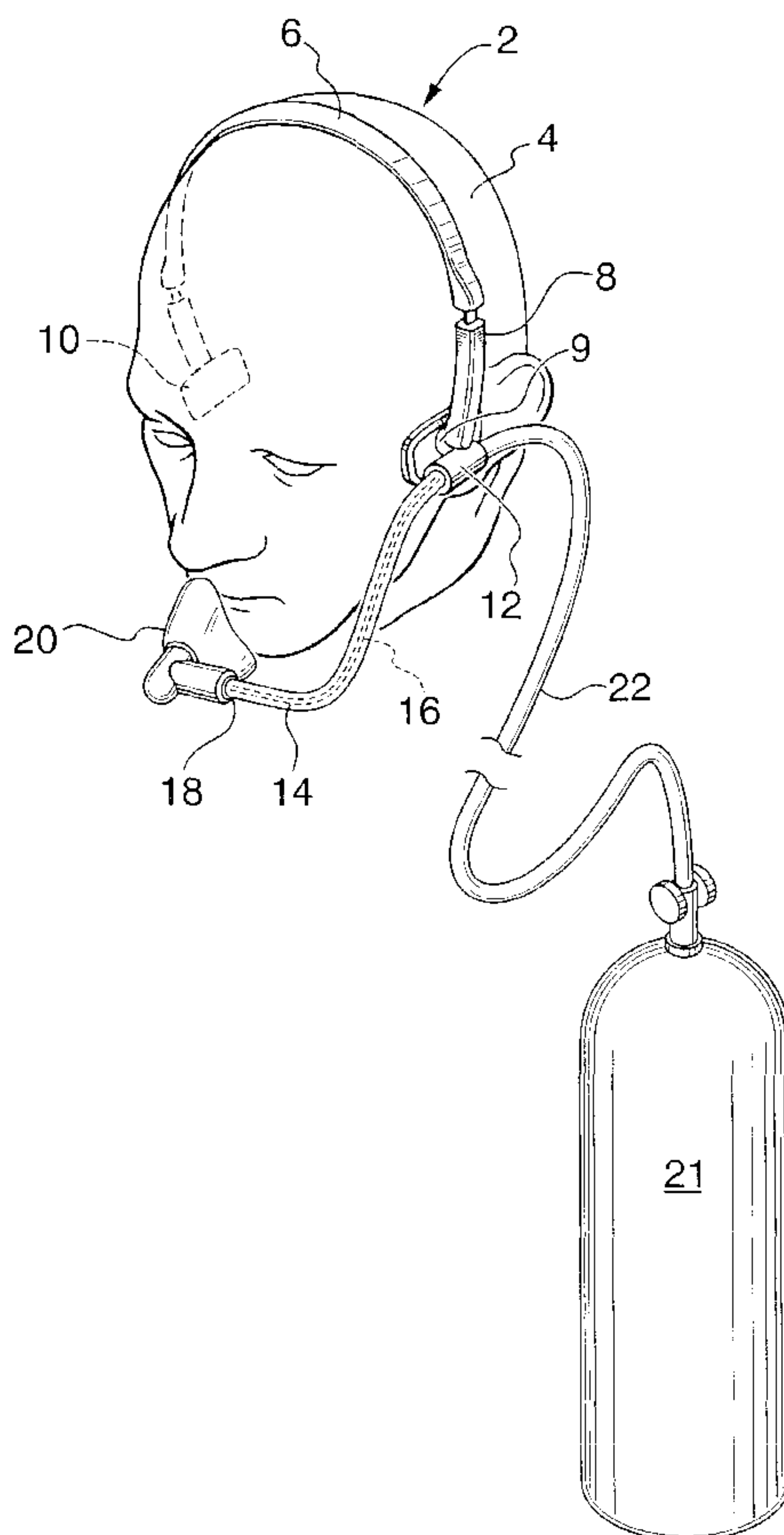




(86) Date de dépôt PCT/PCT Filing Date: 2001/05/07  
 (87) Date publication PCT/PCT Publication Date: 2001/11/22  
 (85) Entrée phase nationale/National Entry: 2002/11/18  
 (86) N° demande PCT/PCT Application No.: CA 2001/000622  
 (87) N° publication PCT/PCT Publication No.: 2001/087394  
 (30) Priorités/Priorities: 2000/05/17 (09/572,637) US;  
 2001/05/04 (09/849,863) US

(51) Cl.Int.<sup>7</sup>/Int.Cl.<sup>7</sup> A61M 16/06  
 (71) Demandeur/Applicant:  
 SOUTHMEDIC INCORPORATED, CA  
 (72) Inventeurs/Inventors:  
 LAVIMODIERE, MAURICE JR., CA;  
 MCDONALD, LEE, CA  
 (74) Agent: RIDOUT & MAYBEE LLP

(54) Titre : SYSTEME DE DISTRIBUTION D'OXYGENE A UN PATIENT  
 (54) Title: PATIENT OXYGEN DELIVERY SYSTEM



(57) Abrégé/Abstract:

A lightweight oxygen delivery system for a patient comprising a curved resilient headband to extend from side to side over a patient's head and to be comfortably seatably engaged thereon. A clip is secured towards one end of the headband. An

(57) **Abrégé(suite)/Abstract(continued):**

elongated tubular boom is secured at one end to the clip to extend and hold its position, when in operation from said one end at the clip to another end located at a space in front of, and proximal to the patient's nose and mouth. An oxygen diffuser port is located at the other end of the boom, to deliver oxygen from the boom to the space in the vicinity of the patient's nose and mouth. The clip is constructed so as to hold securely an oxygen delivery tube from an oxygen source in fluid communication with said one end of the boom so as to deliver oxygen from the source to the boom for discharge through the diffuser.

(12) INTERNATIONAL APPLICATION PUBLISHED UNDER THE PATENT COOPERATION TREATY (PCT)

(19) World Intellectual Property Organization  
International Bureau(43) International Publication Date  
22 November 2001 (22.11.2001)

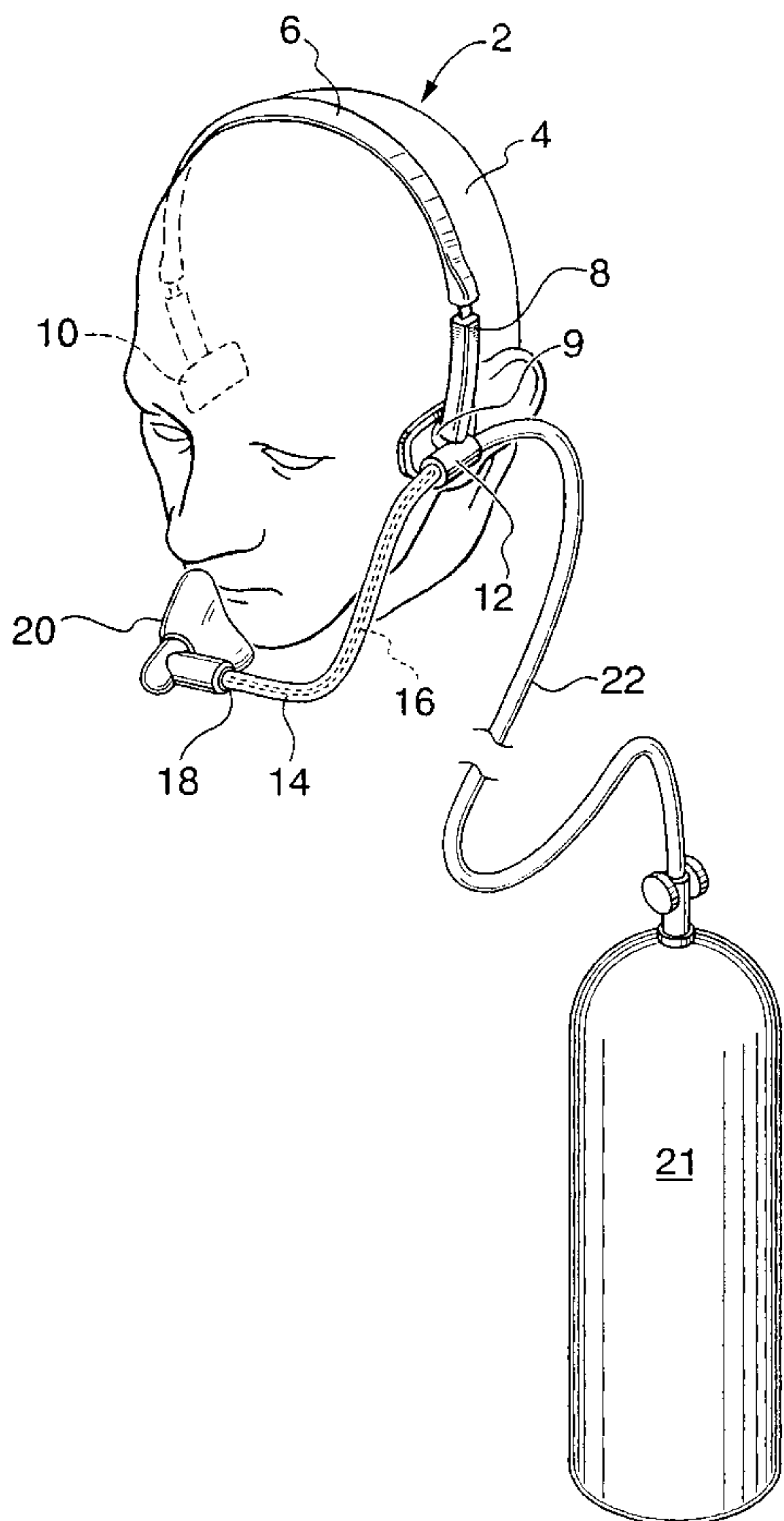
PCT

(10) International Publication Number  
**WO 01/87394 A3**

- (51) International Patent Classification<sup>7</sup>: **A61M 16/06**
- (21) International Application Number: PCT/CA01/00622
- (22) International Filing Date: 7 May 2001 (07.05.2001)
- (25) Filing Language: English
- (26) Publication Language: English
- (30) Priority Data:  
09/572.637 17 May 2000 (17.05.2000) US  
09/849.863 4 May 2001 (04.05.2001) US
- (71) Applicant: **SOUTHMEDIC INCORPORATED**  
[CA/CA]; 50 Alliance Blvd., Barrie, Ontario L4M 5K3  
(CA).
- (72) Inventors: **LAVIMODIERE, Maurice, Jr.**; 205 Cardinal Street, Barrie, Ontario L4M 6G8 (CA). **MCDONALD, Lee**; 34 Royal Oak Drive, Barrie, Ontario L4M 4S6 (CA).
- (74) Agent: **KENT, W., Charles**; Ridout & Maybee LLP, 150 Metcalfe Street, 19th Floor, Ottawa, Ontario K2P 1P1 (CA).
- (81) Designated States (*national*): AE, AG, AL, AM, AT, AU, AZ, BA, BB, BG, BR, BY, BZ, CA, CH, CN, CR, CU, CZ, DE, DK, DM, DZ, EE, ES, FI, GB, GD, GE, GH, GM, HR, HU, ID, IL, IN, IS, JP, KE, KG, KP, KR, KZ, LC, LK, LR, LS, LT, LU, LV, MA, MD, MG, MK, MN, MW, MX, MZ, NO, NZ, PL, PT, RO, RU, SD, SE, SG, SI, SK, SL, TJ, TM, TR, TT, TZ, UA, UG, UZ, VN, YU, ZA, ZW.
- (84) Designated States (*regional*): ARIPO patent (GH, GM, KE, LS, MW, MZ, SD, SL, SZ, TZ, UG, ZW), Eurasian patent (AM, AZ, BY, KG, KZ, MD, RU, TJ, TM), European patent (AT, BE, CH, CY, DE, DK, ES, FI, FR, GB, GR, IE, IT, LU, MC, NL, PT, SE, TR), OAPI patent (BF, BJ, CF, CG, CI, CM, GA, GN, GW, ML, MR, NE, SN, TD, TG).

[Continued on next page]

(54) Title: PATIENT OXYGEN DELIVERY SYSTEM



(57) Abstract: A lightweight oxygen delivery system for a patient comprising a curved resilient headband to extend from side to side over a patient's head and to be comfortably seatably engaged thereon. A clip is secured towards one end of the headband. An elongated tubular boom is secured at one end to the clip to extend and hold its position, when in operation from said one end at the clip to another end located at a space in front of, and proximal to the patient's nose and mouth. An oxygen diffuser port is located at the other end of the boom, to deliver oxygen from the boom to the space in the vicinity of the patient's nose and mouth. The clip is constructed so as to hold securely an oxygen delivery tube from an oxygen source in fluid communication with said one end of the boom so as to deliver oxygen from the source to the boom for discharge through the diffuser.

WO 01/87394 A3

**WO 01/87394 A3**



**Published:**

— *with international search report*

*For two-letter codes and other abbreviations, refer to the "Guidance Notes on Codes and Abbreviations" appearing at the beginning of each regular issue of the PCT Gazette.*

**(88) Date of publication of the international search report:**

2 May 2002

- 1 -

**TITLE OF THE INVENTION****PATIENT OXYGEN DELIVERY SYSTEM****BACKGROUND OF THE INVENTION**

5 The present invention relates to a novel system for delivery of oxygen to a patient, and more particularly relates to a device which can be used to replace conventional oxygen masks and nose cannula oxygen delivery systems.

Mask oxygen therapy has been around for a very long time and has seen virtually no changes. Problems encountered with this style of therapy are well known but unavoidable using the mask as it is supplied today. A number of vendors supply oxygen masks as a commodity item, with the result that there has been little or no improvement in the technology because of the low profit margins accompanying the sale of such masks.

15 Conventional oxygen masks comprise tent like structures which are strapped over the nose and mouth of a patient, often using an elastic band or bands behind the patient's ears or head. Oxygen is fed from a supply through a tube into the bottom portion of the mask at the front of the patient.

Common problems with the mask include:

1. Some patients find it claustrophobic.
- 20 2. Many patients cannot tolerate the smell of plastic resin.
3. Patients must take the mask off to speak or eat thereby discontinuing therapy.
4. Some patients are allergic to the elastic (latex allergy).
5. Some patients feel ill when they wear an oxygen mask, (the psychological effect is truly remarkable on the patient and the patient's family alike).
- 25 6. Patients often aspirate if they vomit while wearing the mask.
7. The mask cannot be used during facial surgery due to intrusion

- 2 -

into the sterile field.

8. The mask cannot be worn if the patient has facial injuries such as burns.
9. Skin irritation is often found from the plastic.
- 5 10. The face mask does not effectively fit all sizes and shapes of face. Often the soft plastic masks are delivered in a deformed fashion.
11. The face mask usually necessitates clipping the oxygen delivery tube in front of the patient at the bottom of the mask. This is awkward and inconvenient as it may interfere with a patient's movement.
- 10 12. The face mask creates irregular infusion of oxygen by the patient, with exhaled air from the patient being mixed with oxygen in the mask.

Another current approach to oxygen delivery to a patient employs  
15 an oxygen delivery tube with tubular open ended nasal prongs or cannulae, at the delivery end of the tube, for insertion into a patient's nasal passages.

Disadvantages of nasal cannulas include:

1. The patient may not be a nose breather.
2. Sinus irritation of the patient.
- 20 3. Patients find the front oxygen cord, necessary with nasal cannulas, difficult to handle as it hangs down directly in front of them and applies downward pressure on their ears, where the cord is again suspended, as in the case of masks.

Of background interest is U.S. Patent No. 4,593,688 of Payton  
25 issued June 10, 1986, which describes and illustrates a tubular system for, example, delivering nebulized oxygen enriched fog or the like to the face and mouth of a croup patient, the tube being suspended, at its delivery end, from a series of straps secured about a patient's head. A portion of the tube is mounted on a pivoting, u-shaped frame member so that the tubing is held in front of and  
30 below the patient's face, for delivery of the nebulized oxygen-enriched fog. The gas delivery to the nose and mouth area of the patient is through orifices in the

- 3 -

tube, near the patient's nose and mouth when the tube is in position. This system is intended for children, and would be uncomfortable and restrictive to one's movements, if placed in position on a patient for a long period of time.

5           Also of background interest is U.S. Patent No. 6,065,473 issued May 23, 2000 of McCombs et al. This reference describes and illustrates an oxygen delivery system for non-medical uses, for instance in oxygen bars or for oxygen enhancing during exercises such as aerobics or weight lifting. The system comprises a re-usable headset and a conduit to direct oxygen from a  
10 source to a headset and to a region proximate to the user's nose and mouth. The conduit is supported by a delivery arm which is preset to a predetermined distance from a user's head for proper supply of oxygen to the user's nose and mouth area.

          Also relevant is Knoch et al U.S. Patent No. 5,575,282 issued  
15 November 19, 1996, which describes and illustrates a distribution system for oxygen to a patient's nose and mouth. This system includes a helix for mixing and spirally delivering oxygen towards the patient.

          German laid open specification DE 43 07 754 A1 (Giesen) discloses an oxygen delivery system comprising a headband with a boom  
20 attached with a gas conduit associated with the boom. A mask body is fastened to the free end of the boom at a position forwardly displaced from a user's face. The mask body physically covers a small portion of the user's face such as the nose, or alternatively consists of a diffuser for directing a stream of gas towards the users nose and mouth.

25           U.S. patent 5,697,363 to Hart discloses a headband extending over a patient's head, with a pair of arms extending from either side of the headband to support a mask in front of a patient's face, covering the patient's nose.

- 3a -

It may be noted that in the disclosure and claims of this present patent specification, directional references are frequently employed such as "up" and "down". Such references are used solely for the purpose of convenience and are not intended to limit the scope of the invention in any respect. In particular, such references refer to the device when positioned with a cup-like mask facing directly upwardly in the position shown e.g. in figure 6. It will be understood that the device may be used in any orientation and in fact when in normal use, the cup would usually be oriented generally horizontally as shown in e.g. Figure 5.

### SUMMARY OF THE INVENTION

It is an object of the present invention to provide a lightweight system for delivery of oxygen to a patient, which avoids many of these problems of conventional masks and nasal cannulae, and which is suited for medical use.

The present invention comprises an oxygen delivery system, intended to be worn by a patient for delivery of gas to a patient's nose and mouth region. The invention comprises a grip for gripping a patient's head, such as a headband or ear grip, with a forwardly-protruding arm or boom supported by the grip. An end of the boom extends forwardly of the patient's face, when worn by a patient. A gas conduit is associated with the boom, for example a tube supported by the boom or a bore extending through the interior of the boom. The conduit communicates with a gas diffuser mounted to the boom at a position which permits the diffuser to be positioned in front of the patient's face, with a gap between the diffuser and the patient's face. The diffuser includes a concave interior surface opening towards the user's face, with an oxygen outlet opening into the concave interior space of the diffuser. The diffuser is characterized by a baffle within the concave interior of the diffuser in the path of gas flow for inducing a transition from jet flow to turbulent flow of the gas stream entering into the diffuser from the

- 3b -

gas outlet. In order to achieve this result, the baffle has a generally concave surface facing the path of gas exiting from the gas outlet, and spaced apart from  
5 the gas outlet. Preferably, the baffle comprises a stem extending from the base of the diffuser body, with a cap at the upper end of the stem having a concave lower face. The stem and cap together form a generally mushroom-shaped configuration. Preferably, two gas outlets are provided on either side of the stem, producing a balanced turbulent gas flow. Further, in order to improve the  
10 flow characteristics of gas directed towards the patient, the diffuser preferably has a cup-like body, having a lower portion with diverging side walls merging with an upper rim portion having generally parallel i.e. vertical, side walls, preferably with a very slight outward flaring near the rim.

15 In accordance with a preferred embodiment of the present invention there is provided a lightweight oxygen delivery system for a patient comprising a curved resilient headband to extend from side to side over a patient's head and to be comfortably seatably engaged thereon. A clip is secured towards one end of the headband. An elongated tubular boom is  
20 secured at one end to the clip to extend and hold its position, when in operation from said one end at the clip to another end located at a space in front of, and proximal to the patient's nose and mouth. An oxygen diffuser port is located at the other end of the boom, to deliver oxygen from the boom to the space in the vicinity of the patient's nose

- 4 -

and mouth. The clip is constructed so as to hold securely an oxygen delivery tube from an oxygen source in fluid communication with said one end of the boom so as to deliver oxygen from the source to the boom for discharge through the diffuser.

5           In an alternative embodiment of the present invention the boom further comprises a second tube for oxygen/carbon dioxide monitoring. This second tube is secured at one end to the clip and has at its other end an oxygen/carbon dioxide inlet port when in operation to be located at a space proximal to the patient's nose and mouth. The clip is constructed so as also to  
10 hold securely an oxygen/carbon dioxide monitor tube in fluid communication with the oxygen/carbon dioxide tube of the boom, for delivery of oxygen/carbon dioxide from the space in the vicinity of the patient's nose and mouth to an oxygen/carbon dioxide monitor.

          In yet a further alternative embodiment of the invention, an  
15 elongated rigid sleeve is provided, one end of which is pivotably mounted to an exterior side of the headband near an end thereof, to rotate 360° with respect to the headband about an axis passing through the headband and a portion of the sleeve where it is mounted. An elongated tubular boom is secured within the sleeve to extend from the other end of the sleeve so that the free end of the  
20 boom is located when in operation at a space in front of, and proximal to, the patient's nose and mouth. An oxygen diffuser is positioned at said free end of the boom. In operation, oxygen is delivered from the boom to the space in the vicinity of the patient's nose and mouth. The end of the boom within the sleeve, and the sleeve, are constructed so as to hold a portion of an oxygen delivery  
25 tube from an oxygen source in fluid communication with that end of the boom so as to deliver oxygen from the source to the boom for discharge through the diffuser.

          The system of the present invention, as will be described in more detail subsequently, avoids many of the problems inherent with conventional  
30 medical oxygen delivery systems such as face masks and nasal cannulae. It has no facial contact and allows both nose and mouth breathing preferences

with more efficient oxygen delivery.

### **BRIEF DESCRIPTION OF THE DRAWINGS**

These and other advantages of the invention will become apparent upon reading the following detailed description and upon referring to the drawings in which:-

FIGURE 1 is a perspective view of an oxygen delivery system according to the present invention mounted on the head of a patient.

FIGURE 2 is a perspective view of an alternative embodiment of oxygen delivery system according to the present invention.

FIGURE 3 is a perspective view of yet a further alternative embodiment of oxygen delivery system according to the present invention.

FIGURE 4 is a section view of the diffuser port of the devices of Figures 1, 2 and 3.

FIGURE 5 is a perspective view of a further embodiment and of an oxygen delivery device according to the present invention mounted on the head of a patient.

FIGURE 6 is a section view of the diffuser of the device of Figure 5.

FIGURE 7 is a side view of the diffuser of the device of Figure 5 in position in front of the face of a wearer.

FIGURE 8 is a schematic side view of the device of Figure 5 on a wearer's head, illustrating the adjustability of the headband.

FIGURE 9 is a partial view of the device of Figure 5 showing the sleeve, boom and oxygen inlet tube.

FIGURE 10 is a partial view of the boom of the device of Figure 5 when worn on a patient, illustrating its positioning flexibility.

FIGURE 11 is a graph illustrating oxygen concentrations delivered to patient's in percentages, based on flow rate settings, of the device of Figure 5 when situated at a distance of 2 cm from a wearer's face, when compared to

- 6 -

oxygen concentrations delivered by a conventional oxygen mask.

FIGURES 12a and 12b are schematic views, from the side, showing the concentration of oxygen in the air around the diffuser body during operation of the system, respectively when the patient is not inhaling, and when  
5 the patient inhales.

While the invention will be described in conjunction with illustrated embodiments, it will be understood that it is not intended to limit the invention to such embodiments. On the contrary, it is intended to cover all alternatives, modifications and equivalents as may be included within the spirit and scope of  
10 the invention, as defined by the appended claims.

### **DETAILED DESCRIPTION OF THE PREFERRED EMBODIMENTS**

In the following description, similar features in the drawings have been given similar reference numerals.

Turning to Figure 1, there is shown a lightweight delivery system  
15 2, in accordance with the invention, mounted on the head 4 of a patient. The system comprises a curved resilient headband 6 which is provided with suitable adjustment means such as telescopic portions 8 and swivel connections 9, to enable the headband to be seated comfortably, from side to side over or behind the patient's head (or in positions therebetween). A pair of soft pads 10, made  
20 of rubber or other suitable material, are secured to swivel connections 9 and to the insides of the end portions of headband 6. To one side of headband 6 is secured a clip 12, which in the illustrated embodiment is of sleeve-like configuration. Secured to clip 12 is a tubular boom 14 which extends downwardly and forwardly to end, as illustrated, at a space in the vicinity of the  
25 patient's nose and mouth. Boom 14 is preferably a plastic tube in which is embedded a positioning wire 16 which enables the tube to be bent into an appropriate shape to position the lower end 18 of boom 14 appropriately for delivery of oxygen to the patient, and to be held in that position. At this lower end 18 of boom 14 is secured an oxygen diffuser 20 through which oxygen, fed

- 7 -

into boom 14, is passed into the space in front of the patient's nose and mouth. The boom construction of the system according to the present invention enables adjustment from left to right and from front to back for precise oxygen delivery. The key is that the diffuser 20 preferably sits centrally approximately one to two  
5 centimeters from the patient's mouth and nose. Diffuser 20 allows for the administration of the oxygen flow to the patient without the patient feeling a direct flow of air onto his/her face. From an appropriate oxygen source 21 an oxygen delivery tube 22 extends and is releasably engaged in the sleeve of clip  
10 12 as illustrated for fluid communication with the tubular boom 14. In this manner clip 12 provides for oxygen delivery from tube 22 to boom 14 and diffuser 20.

In Figure 2 there is illustrated a similar oxygen delivery system with the exception that tubular boom 14 incorporates a pair of tubes, one of which (23) is designed for oxygen delivery, the other of which (24) is intended to collect  
15 oxygen/carbon dioxide in the space of the vicinity of the patient's nose and mouth and deliver that sample to an oxygen/carbon dioxide monitor (not illustrated) through tube 26. Tube 26 is releasably secured, during operation, within clip 12, for fluid communication with the corresponding oxygen/carbon dioxide monitor tube 24 of boom 14. Preferably tubes 23 and 24 are of integral  
20 construction. An appropriate oxygen/carbon dioxide inlet port 28 (Figure 4) is associated with diffuser 20, as will be described in more detail subsequently.

The oxygen delivery system according to Figures 1 and 2 is comfortable and adjustable for all head sizes. The use of the thin side cushions allows a patient to lie on his/her side with comfort.

25 While the device of Figures 1 and 2 is shown with a headband, optional means of securing boom 14 in position for oxygen delivery to a patient by means of a conventional over-the-ear mount 30 is shown in Figure 3. Other conventional securing means may also be appropriate.

A preferred form of diffuser 20 is detailed in section in Figure 4. Its  
30 body 32, having an interior surface of generally concave configuration, circumscribes the oxygen outlet end of oxygen delivery tube 23 and directs the

- 8 -

flow of oxygen generally towards the patient's mouth and nose when the diffuser 20 is properly positioned and operational. A mushroom-shaped baffle 36 is seated over oxygen outlet 34 so as to assist in the diffusion of oxygen and avoid a direct flow of oxygen towards the patient's face. Baffle 36 impedes oxygen 5 flow from the rear of the body 32, inducing a transmission from jet to turbulent flow. Details of the shape of the baffle 36 and body 32 directly influence the mixing characteristics between pure oxygen stream and the ambient air (containing approximately 21% oxygen by volume), and thus determine the oxygen content of the plume of oxygen-enriched air delivered from the diffuser 10 to the surface of the patient's face. As illustrated, the baffle 36 may have a passageway 38 to permit gas analysis of expired gases, passageway 38 constituting a sampling port which is bored on center and axially through the stem 40 of baffle 36.

As well, body 32 of diffuser 20 has a contoured inner surface, 15 forming a somewhat triangular cup shape which follows the shape of the nose/mouth nexus of a patient, thereby forming a shaped plume that directs the oxygen stream towards the patient's face. The enclosed volume of that cup may be modified to accommodate a larger plume and increase the total oxygen delivered during respiratory inspiration. As can be seen in Figure 4, the wall of 20 body 32, near outer rim 48 becomes more "vertical" (with opposite sides being parallel) than outwardly extending, as are the lower portions of the body. This shaping of the rim edges of the body permits a concentrating of oxygen and a shaping of the plume of oxygen-enriched air, providing a more precise direction of that plume towards the patient's nose/mouth. The body 32 of diffuser 20 25 swivels about the oxygen outlet 34 to enable proper orienting of the diffuser when the boom is in either left hand or right hand mode.

Of course the overall shaping of body 32 and baffle 36 may be modified to suit the requirements of a particular application or user need.

Where the delivery system incorporates an oxygen/carbon dioxide 30 monitoring function, a passage way 38 through the stem 40 of baffle 36 communicates directly with oxygen/carbon dioxide monitor tube 24, thereby

- 9 -

enabling a sample of oxygen or carbon dioxide, in the region of the patient's mouth and nose, to be drawn to the oxygen/carbon dioxide monitor (situated at a remote location)

It is also envisaged that a ridge or a plurality of scented material holding pockets 46, in the surface of diffuser body 32 may be provided for purposes of aroma therapy a layer of scented material may be coated on the back of diffuser 20 .

In the alternative embodiment of system 2 illustrated in Figures 5 to 9, there is provided a curved resilient headband 50 which is of a sufficient size to fit most heads without exerting too much pressure. The headband has widened ends 52 which gently grip the patient's head, spreading the pressure over these widen ends, so as to hold the headband in position when on a patient's head. The inner surfaces of ends 52 are provided with inwardly extending ridges 54 (Figure 9) which facilitate the gripping action. As well, apertures 56 in the wider upper portion 58, by capturing some of the patient's hair (where the patient has hair) within, further assist in maintaining the head set in a particular position against unintended dislodgement on a patient's head. The headband is for example made of stiff nylon which gives good tensile strength and resiliency. Figure 8 illustrates various positions and the range of positions, for headband 50 to be operatively positioned on a patient's head.

To one of the widened ends 52 of headband 50 is pivotably secured at pivot 59 sleeve 60. This pivot is illustrated as being a screw. Alternatively, other conventional pivot means may be used. As well, although not illustrated, it is envisaged that headband 50 may be provided with detachable securing means for sleeve 60, so that sleeve 60, boom 62 and diffuser 20 may be replaced on a particular headband 50. This pivoting occurs about an axis (A) as illustrated extending laterally through the upper end of sleeve 60 and associated headband 50. This pivoting motion permits the headband to have the range of motion illustrated in Figure 8, relative to the sleeve, and further enables the sleeve to be pivoted 180° to convert the system from a left hand one, as illustrated, to a right hand one, as will be described in

- 10 -

more detail subsequently. Longitudinally slidably secured in sleeve 60 is a tubular boom 62 which extends downwardly and forwardly to end, as illustrated, at a space in the vicinity of the patient's nose and mouth. Boom 62 is preferably a plastic tube in which is embedded a positioning wire 64 which enables the tube  
5 to be bent into an appropriate shape to position the lower end 66 of boom 62 appropriately for delivery of oxygen to the patient, and to be held in that position, as illustrated in Figure 10.

At this lower end 66 of boom 62 is secured an oxygen diffuser 20 similar to that of Figure 1 to 4 through which oxygen, fed to boom 62, is passed  
10 into the space in front of the patient's nose and mouth. It is preferred that the distance between the patient's face and the diffuser be about 2 cm or less, as can be seen in Figure 7. Diffuser 20 is constructed so as to allow for administration of the oxygen flow to the patient without the patient feeling a direct flow of air onto his or her face. From an appropriate oxygen source (not  
15 illustrated), an oxygen delivery tube 68 extends and is connected to the upper end of boom 62 within sleeve 60 for fluid communication with boom 62. Oxygen delivery tube 68 is preferably frictionally engaged within clip portions 70 of sleeve 60. In operation however, relative longitudinal movement of boom 62 and oxygen delivery tube 68 are permitted, with respect to sleeve 60, as illustrated  
20 in Figure 9, thereby assisting in the proper locating of diffuser 20 with respect to the patient's face, irrespective of the size or shape of the patient's head. The limits of this longitudinal movement can be determined by appropriate positioning of stops 72 on sleeve 70 which for example bear against outwardly extending portions 74 of the inner end of boom 62.

25 Of note, in this embodiment, baffle 76 does not have an inner passage way and the diffuser and boom are not constructed to permit sampling of oxygen and carbon dioxide. Diffuser 20 however still swivels on the lower end of boom 62 so it can be properly oriented for right hand or left hand orientation of the boom on the patient.

30 There are many obvious advantages of the present system, for delivery of oxygen to a patient, over prior art devices, including the lack of facial

- 11 -

contact of the present system, the elimination of the possibility of the patient aspirating should the patient be ill during oxygen therapy, the fact that it allows both nose and mouth breathing preferences and the deflection of oxygen flow away from the face of the user during absence of inhalation, for increased patient comfort. As well, the system according to the present invention enables a patient to eat or speak in an unobstructed manner.

The system according to the present invention permits the headband 6 to be adjusted to be clear of any particular area on a patient's head and adjust for a wide range of patient sizes.

As can be seen in Figures 12A and 12B, a plume 78 of oxygen enriched air leaves the diffuser. In operation, this plume will be in the vicinity of the patient's nose and mouth area. When the patient is not inhaling (Figure 12A), the areas of highest increased oxygen concentration X in plume 78 remain in and near diffuser body 32 with the areas Y of moderately increased oxygen concentration and areas Z of lowest increased oxygen concentration extending outwardly from diffuser body 32 as illustrated. When the patient inhales, as seen in Figure 12B, the areas X and Y of highest and moderate increased oxygen concentrations are drawn towards the patient's mouth and nose area, making these increased oxygen concentrations available to be inhaled by the patient.

In clinical test results which are illustrated in the graph of Figure 11, the actual oxygen concentration for a 2 cm distance of Applicant's device from a patient's face ranges between 46% at a flow rate setting of 2 (approximately litres per minute) to 66% at a flow rate setting of 12 (approximately litres per minute), as compared to an oxygen concentration delivery of between 22% and 30% for flow rate settings of from 2 to 10 in a conventional oxygen mask. Thus, higher concentrations of oxygen can be delivered to a patient, using the system of the present invention, at lower oxygen flow rates, and with conventional face masks, providing a significant saving in oxygen.

Advantages of the present system, for delivery of oxygen to a patient, over prior art devices, include the facts:

- the possibility of the patient aspirating is eliminated should they be

- 12 -

- ill during oxygen therapy,
- it is lightweight,
- it does not give the patient the feeling of being sick, instead it has a high tech look that is positive for the patient,
- 5 – it allows for the sampling and monitoring of expired carbon dioxide directly at the boom end,
- oxygen tubing comes off at the side instead of directly at the bottom of the mask as seen in traditional mask devices, making it easier for nursing staff to handle,
- 10 – the device does not outgas as often happens with full face masks,
- there is no smell of plastic,
- there is no need to remove oxygen therapy while patient is eating or speaking,
- it is well tolerated by patients; it provides comfort not found with traditional devices,
- 15 – it could be reused for a longer period of time than conventional masks and nose cannula systems,
- it allows for the administration humidified air as well as non-humidified air,
- 20 – one size adjusts for a wide range of patient sizes,
- it is effective whether the patient is a mouth or nose breather,
- it permits adjusting to be clear of any particular area on a patient's head.

The oxygen delivery system of the present invention is envisaged  
25 as having particular application where a patient has his/her faculties and is not in a state where the headband might be unintentionally dislodged, or the diffuser and associated boom might be unintentionally displaced from normal, operative position.

As for children, this population traditionally does not tolerate mask  
30 oxygen therapy. The device according to the present invention is not only likely to be considered to be stylish by older children, it also could support decorations

- 13 -

to represent popular cartoon characters, or the like, to appeal to younger children.

Thus, it is apparent that there has been provided in accordance with the invention a lightweight oxygen delivery system that fully satisfies the  
5 objects, aims and advantages set forth above. While the invention has been described in conjunction with an illustrated embodiment thereof, it is evident that many alternatives, modifications and variations will be apparent to those skilled in the art in light of the foregoing description. For example, a multi lumena boom  
10 18, instead of one having a single tube, may be provided, each tube having a distinct function. Another application of the system according to the present invention is for "closed drape" patient, surgical procedures where a microphone  
pick up 80 (Figures 4 and 6) is associated with the baffle 36 or 76 as illustrated, to provide voice pick up and transmission for a patient in surgery. Often such  
patients are required to respond orally to questions from the surgeon, and pick  
15 up microphone 80 is well positioned to receive the patient's response. That response can be conveyed by wires (Figure 4) or by a wireless microphone (Figure 6) to a speaker in the operating room or otherwise. Accordingly, it is intended to embrace all such alternatives, modifications and variations as fall within the spirit and broad scope of the invention.

**CLAIMS:**

1. An oxygen delivery system for a patient comprising:
  - (a) a grip (6, 30, 50) for gripping a patient's head;
  - (b) a boom (14, 60) secured to said grip;
  - (c) a conduit (14, 23, 62) supported by or contained within said boom for delivery of oxygen from an oxygen source;
  - (d) an oxygen diffuser (20) engaged to said boom, to deliver an oxygen stream from said conduit to a space between said diffuser and the patient's face in the vicinity of the patient's nose and mouth, said diffuser (20) comprising a generally concave body (32) having a hollow interior space for opening towards a patient's face, an oxygen outlet (34) communicating with said conduit and opening into the hollow interior of said body and a baffle (36) within said interior of said body (32) located in the path of an oxygen stream exiting said oxygen outlet, characterized by:  
said baffle having a generally concave surface facing said oxygen outlet for inducing a transition from jet flow to turbulent flow of said oxygen stream.
2. A system according to claim 1, wherein said grip comprises a headband provided with means to adjust the size of the headband for comfortable seating on a patient's head.
3. A system according to claim 1, further characterized by a wire (64) embedded in the boom to permit bending of the boom to a particular shape and maintaining of that shape.
4. A system according to claim 1, further characterized by said boom being adjustably fastened to said grip by a clip (60) having a hollow interior so as to receive said boom (62) for telescopic extension of said boom relative to said grip.

- 15 -

5. A system according to claim 1, wherein said baffle comprises an upstanding stem (40) extending from the base of said diffuser and a cap (32) at the upper end of said stem.
6. A system according claim 1, further characterized by said diffuser (20) comprising an exterior wall defined by upper and lower regions, the wall at said lower region diverging apart towards the open end of said diffuser and said upper region (48) being a rim region and comprising a generally vertical wall with opposing sides thereof being generally parallel to each other.
7. A system according to claim 6 wherein the wall at said upper rim region slightly diverges towards said open end.
8. A system as defined in claim 1, wherein said grip (30) comprises an over the ear mount.
9. A system according to claim 5, comprising two spaced apart oxygen outlets at the base of the said diffuser, directed upwardly towards said baffle and on opposing sides of said stem of said baffle.
10. An oxygen delivery system according to claim 1, wherein said boom (62) is fastened to said grip (50) by a pivot mount (59) to be pivotally adjustable by at least about 180° with respect to the grip for reversible left or right hand configuration of said system.
11. A system according to claim 1, further comprising a second conduit (24) designated for gas monitoring, this second conduit having at one end a gas inlet port when in operation to be located at a space proximal to the patient's nose and mouth.

- 16 -

12. A system according to claim 11, wherein said second conduit is an integrally combined part of the boom.
13. A system according to claim 1, wherein a passageway (28, 38) through the baffle communicates directly with said conduit thereby enabling a sample of gas, in the region of the patient's mouth and nose, to be withdrawn.
14. A system according to claim 1 further comprising a source of scented material in the diffuser.
15. A system according to claim 2, wherein the ends of the headband are widened so as to spread the engaging force of the headband on a patient's head.

- 17 -

16. A system according to claim 15, wherein interior surfaces of the widened ends of the headband are provided with inwardly extending ribs to assist in frictionally engaging a patient's head when the headband is in position.
17. A system according to claim 2, wherein the headband is constructed so as to be of a size and shape to enable it to be fit both over or behind a patient's head when its ends are in position on the sides of a patient's head.
18. A system according to claim 2, wherein intermediate portions of the headband are provided with apertures through which a patient's hair may extend, to further facilitate holding the headband in position on a patient's head and prevent it from becoming dislodged from that position.
19. A system according to claim 4, wherein stop means are provided within said clip to limit the telescopic longitudinal adjustment of the boom with respect to the clip between two longitudinal extremities.
20. A system according to claim 1, wherein the boom is constructed so as to be bendable to a particular shape to facilitate its positioning with respect to a patient's nose and mouth.
21. A system according to claim 1, wherein the interior surface of said diffuser has a generally triangular, cup-like shape to follow the shape of the nose/mouth nexus of a patient when in position on a patient.
22. A system according to claim 1, wherein the diffuser includes a microphone to pick up sounds from the patient.

- 18 -

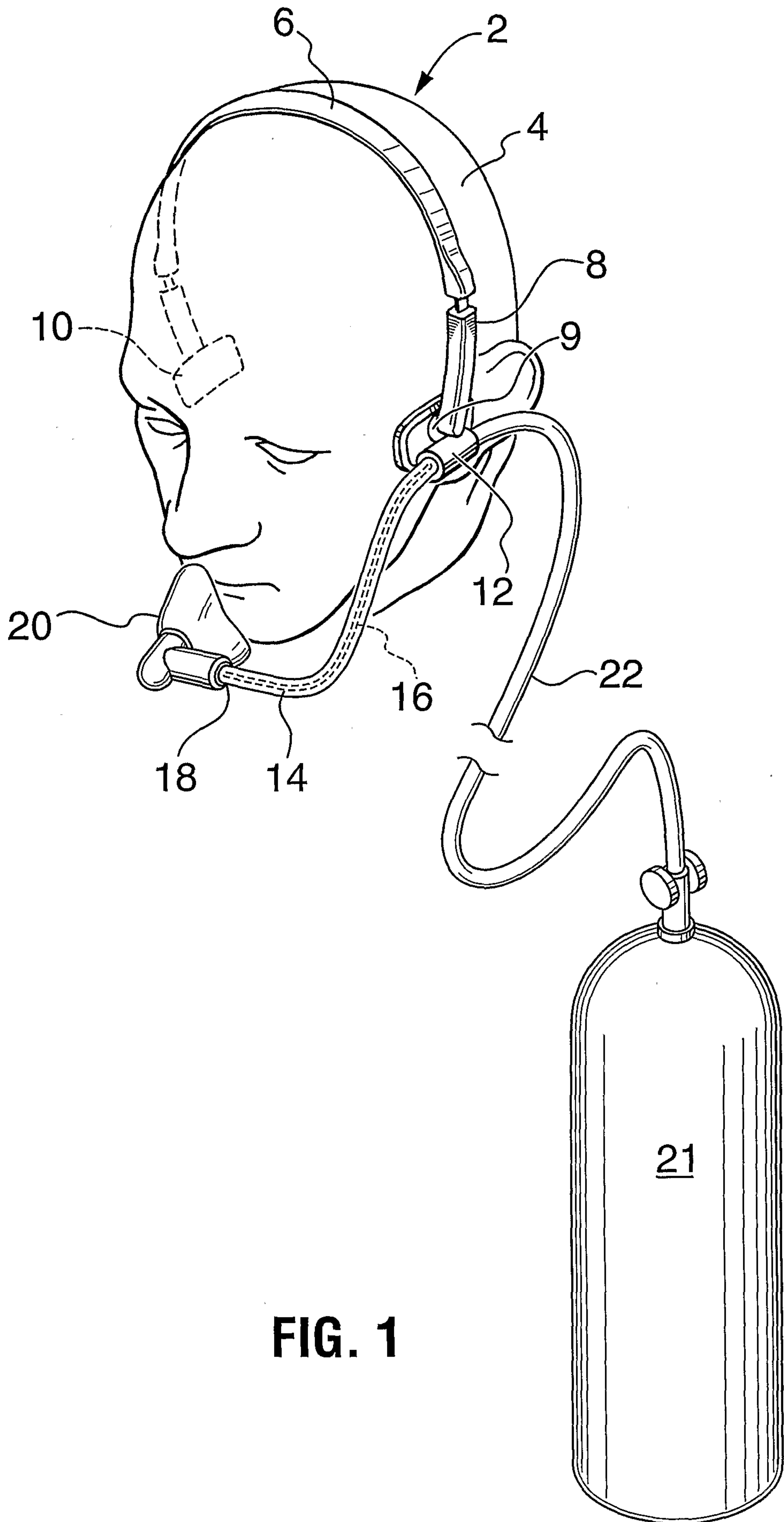
23. An oxygen delivery system for patient comprising:
- a) a grip (6, 30, 50) for gripping a patient's head;
  - b) a boom (14, 60) secured to said grip;
  - c) a conduit (14, 23, 62) supported by or within said boom for delivery of oxygen from an oxygen source;
  - d) an oxygen diffuser (20) engaged to said boom to deliver an oxygen stream from said conduit to a space between said diffuser and the patient's face in the vicinity of the patient's nose and mouth, comprising a generally concave body (32) having a hollow interior space for opening towards a patient's face, an oxygen outlet (34) communicating with said conduit and opening into the hollow interior of said body, characterized by:

said diffuser (20) comprising an exterior wall defined by upper and lower regions, the wall at said lower region diverging apart towards the open end of said diffuser and the wall at said upper region (48) being a rim region of said diffuser and being generally vertical with opposing sides thereof being generally parallel to each other.

24. A system as defined in claim 23 wherein the wall at said upper region rim slightly diverges towards said open end.

25. A system as defined in claim 23, having two spaced apart oxygen outlets at the base of said diffuser.

1/8



**FIG. 1**

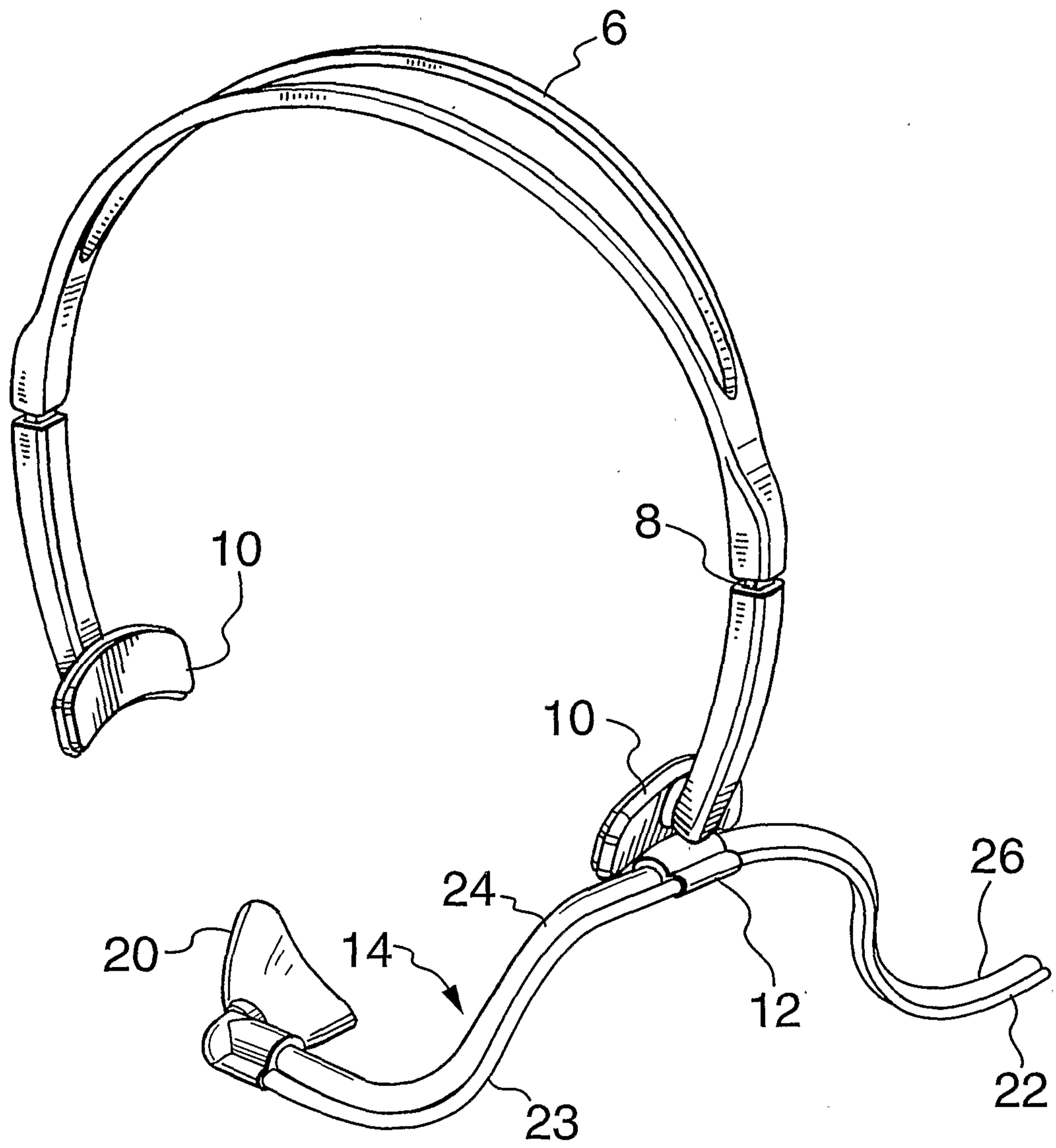
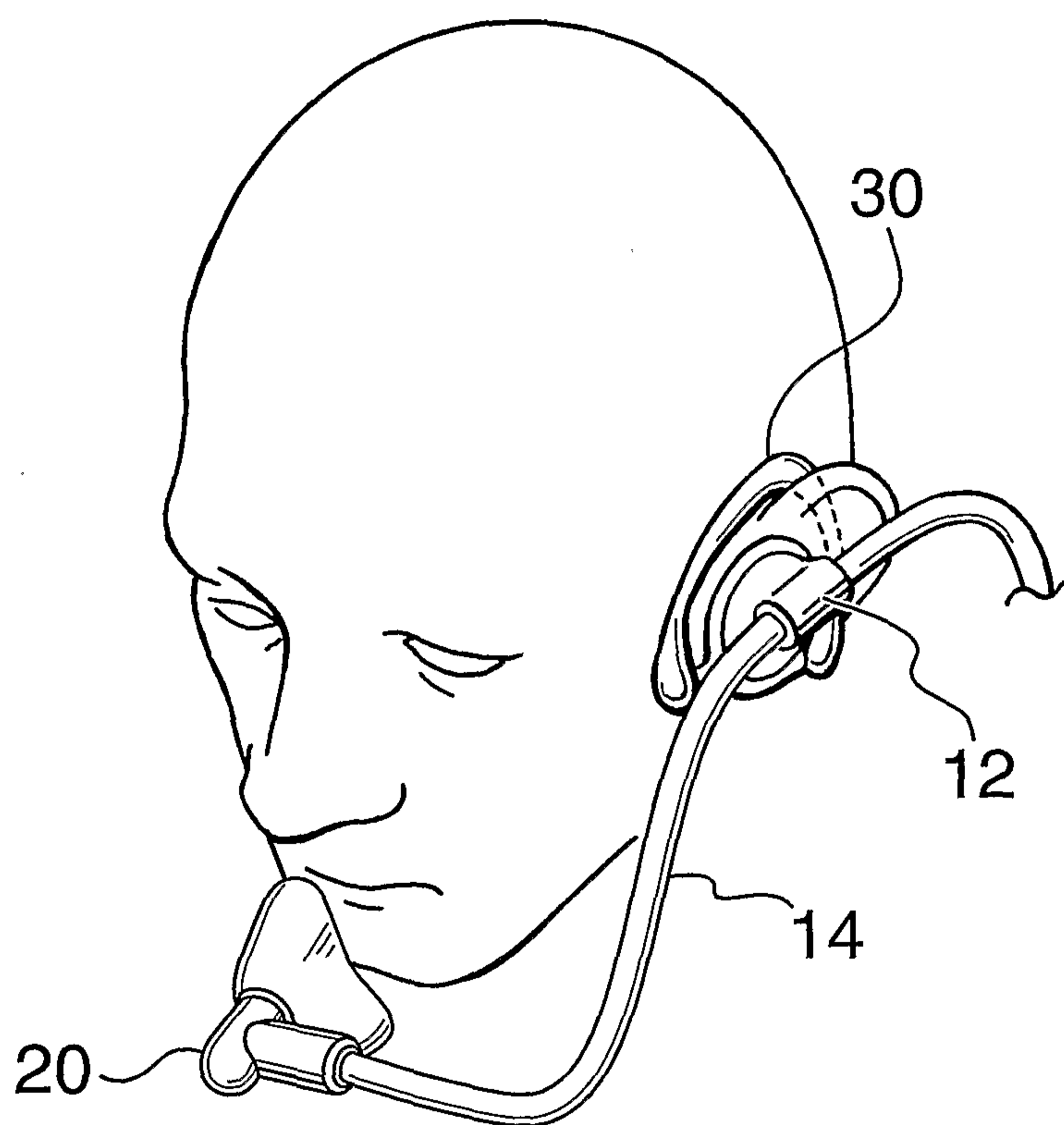


FIG. 2



**FIG. 3**

4/8

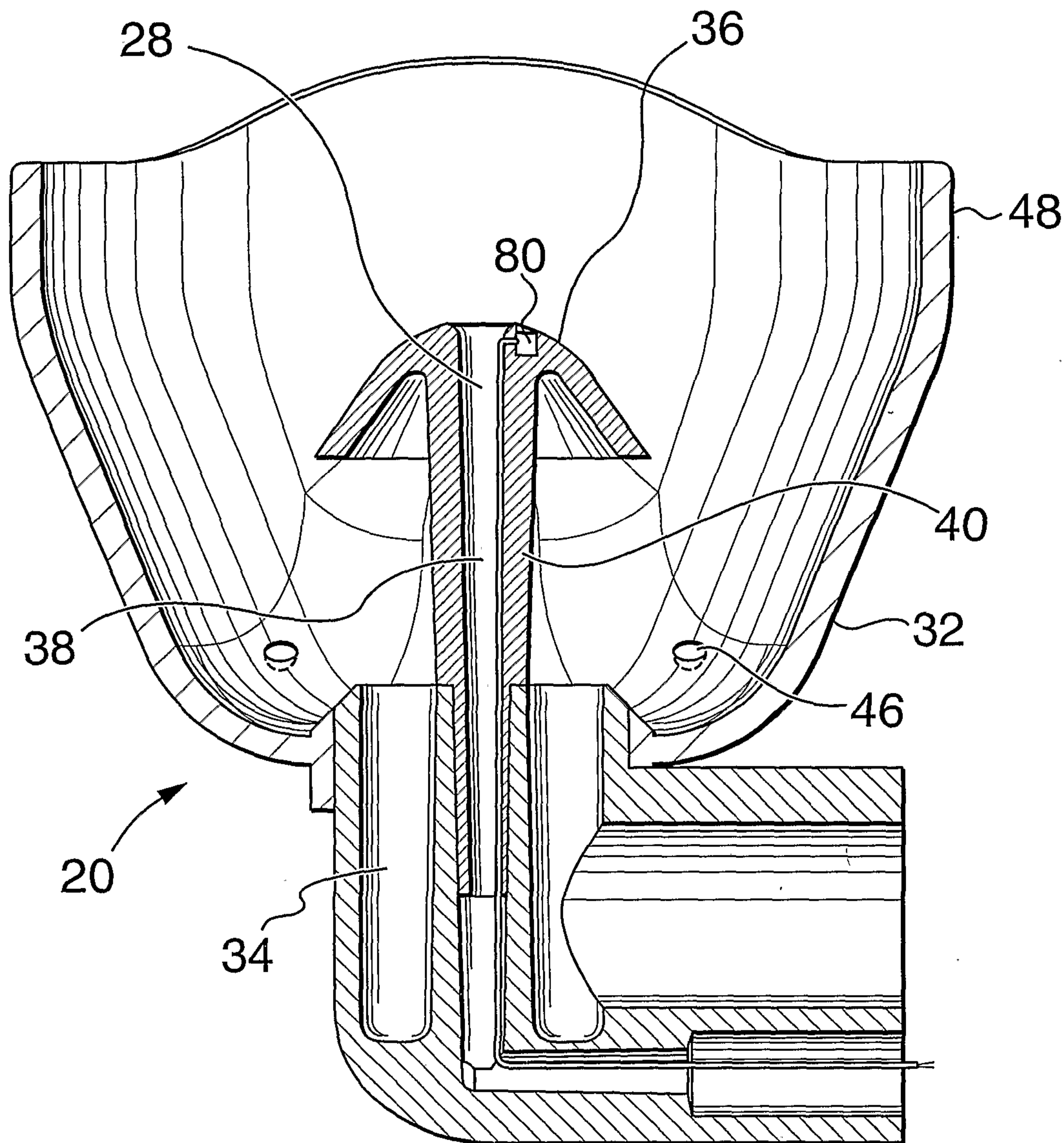
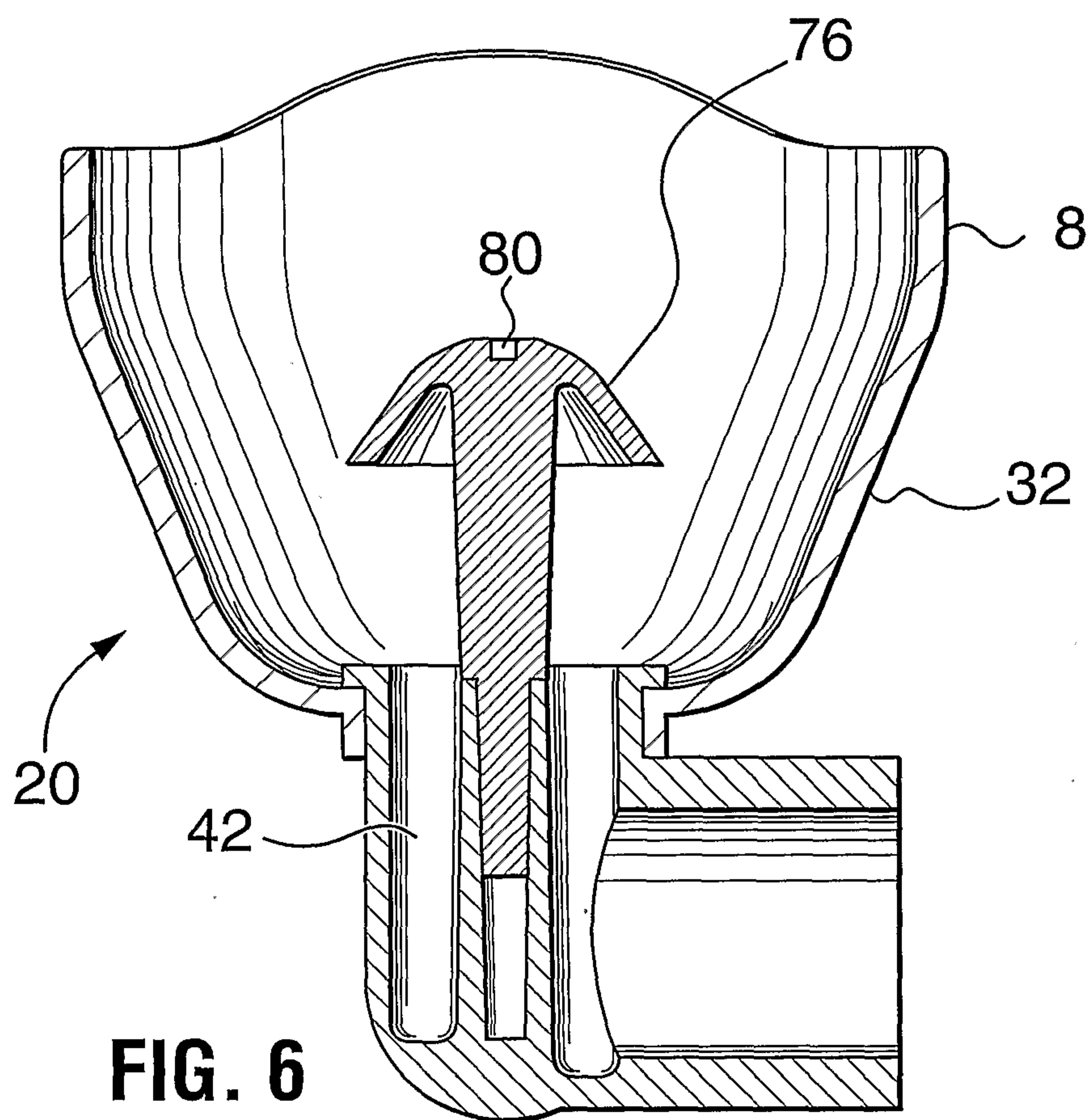
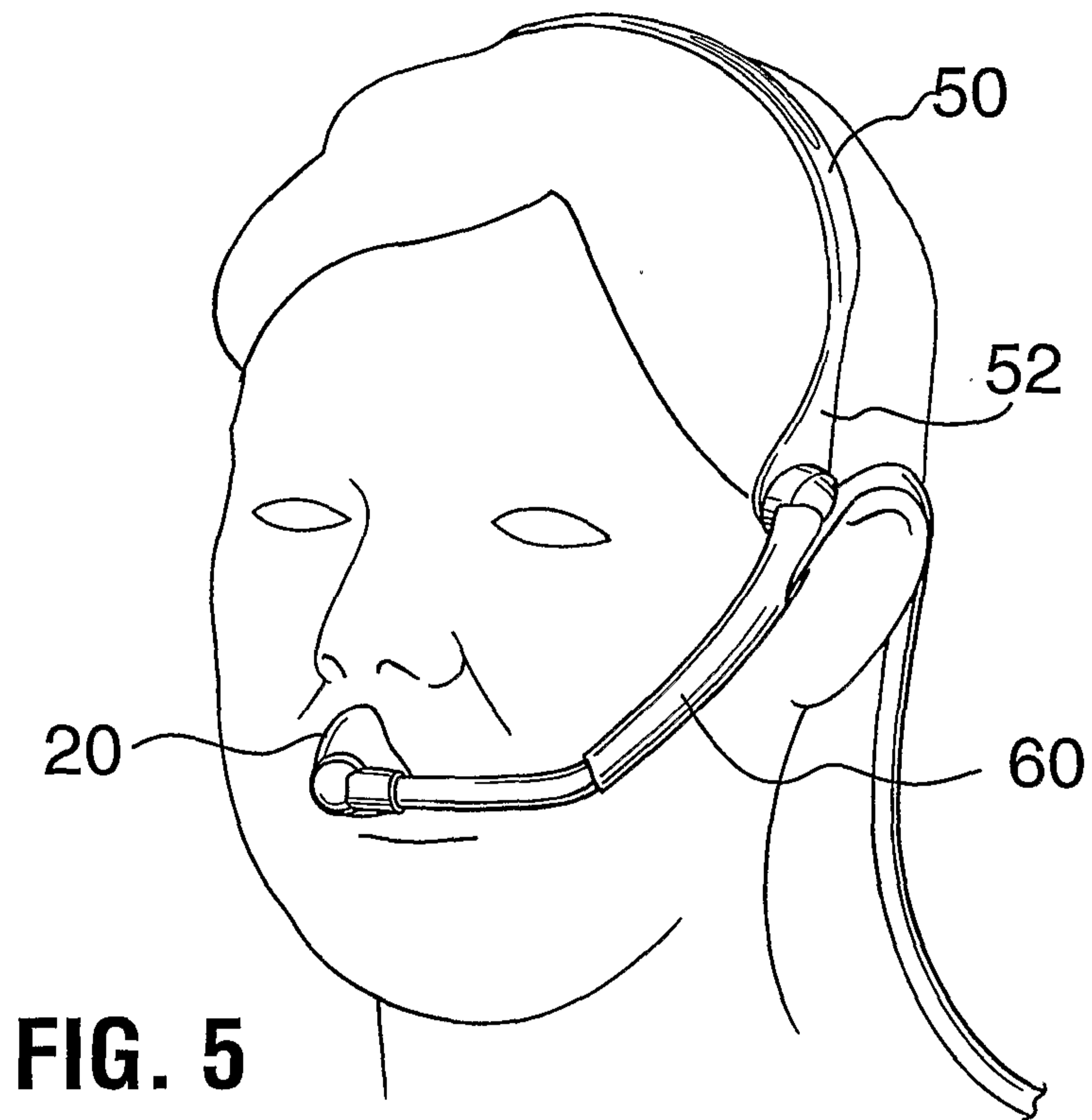
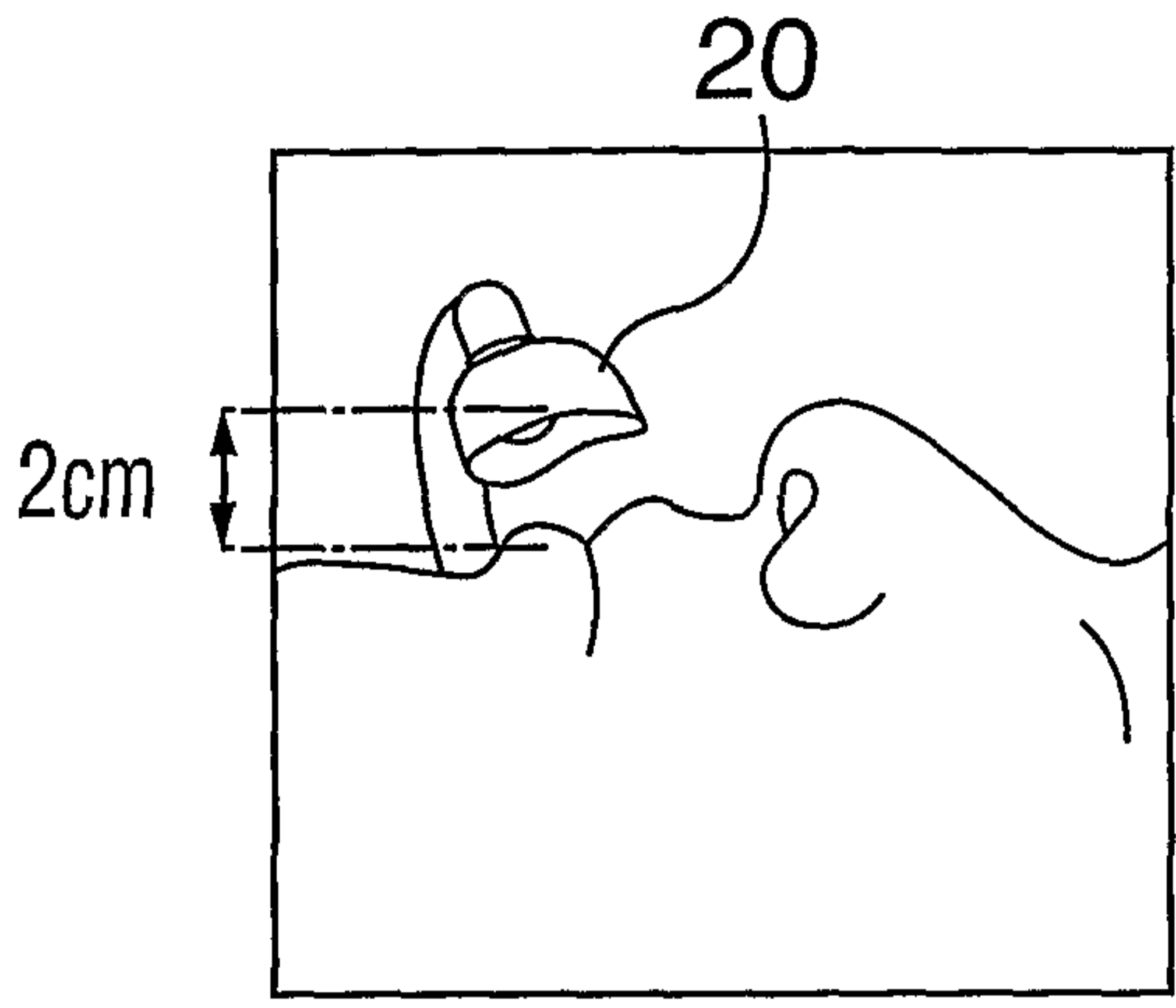


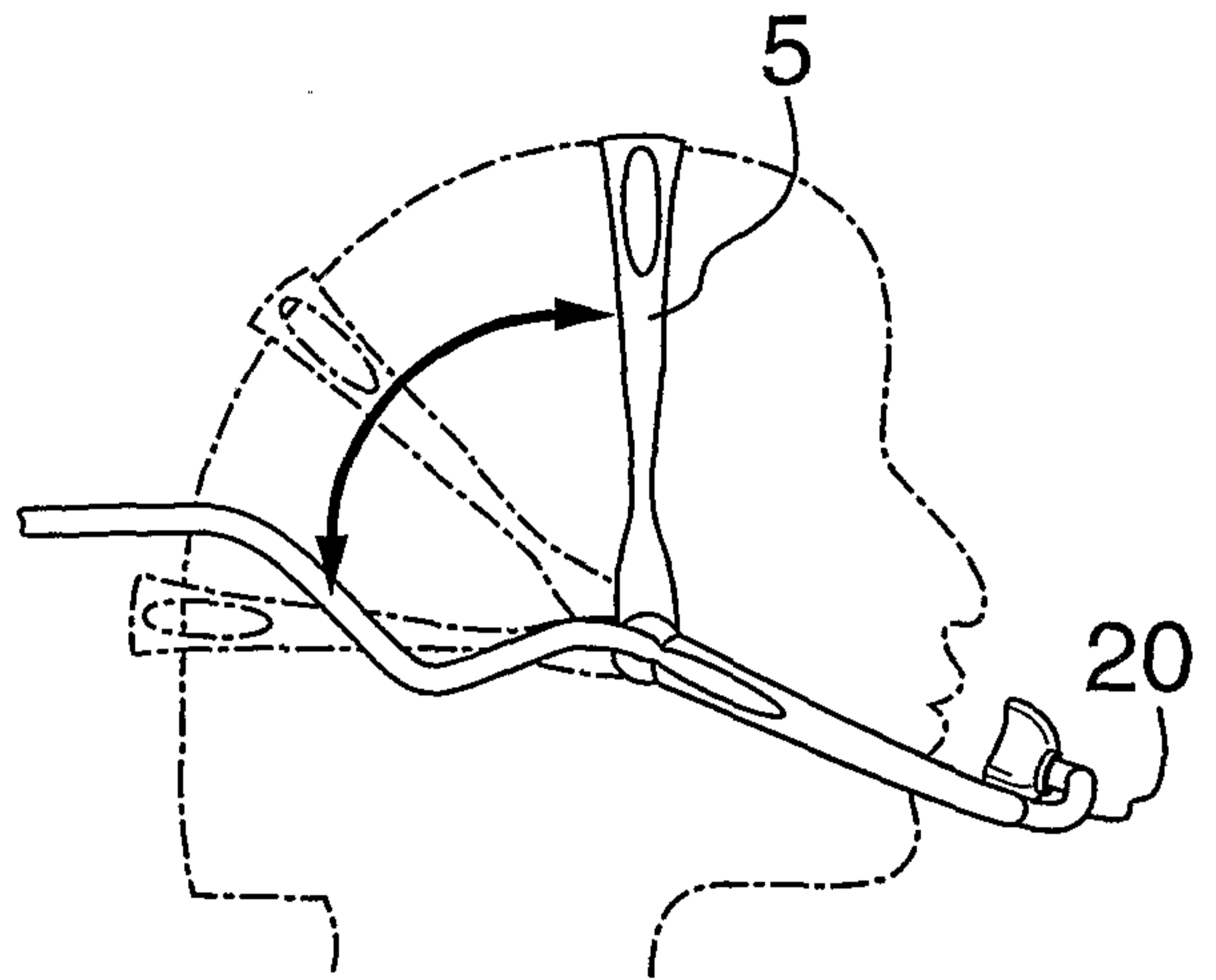
FIG. 4

5/8

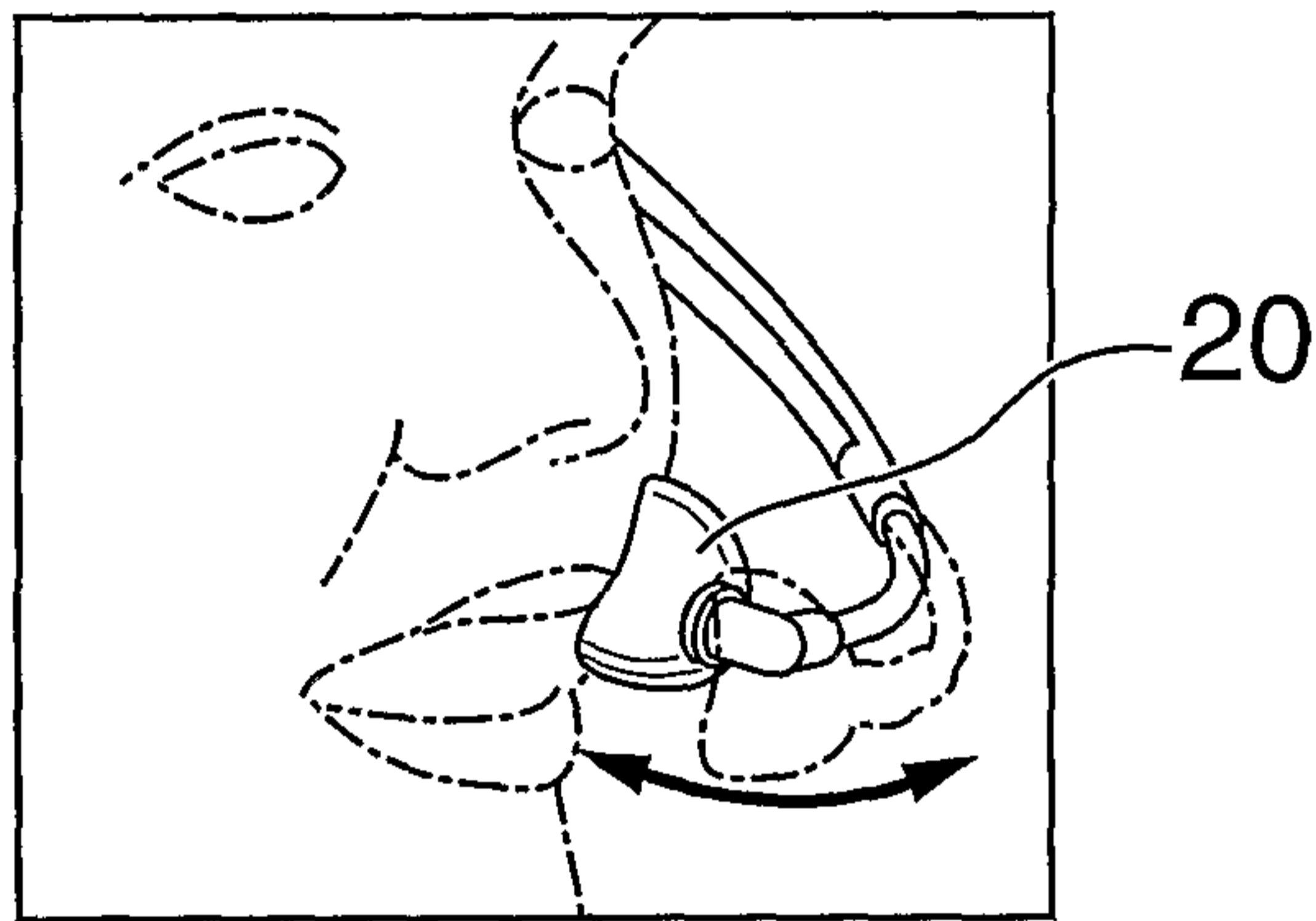




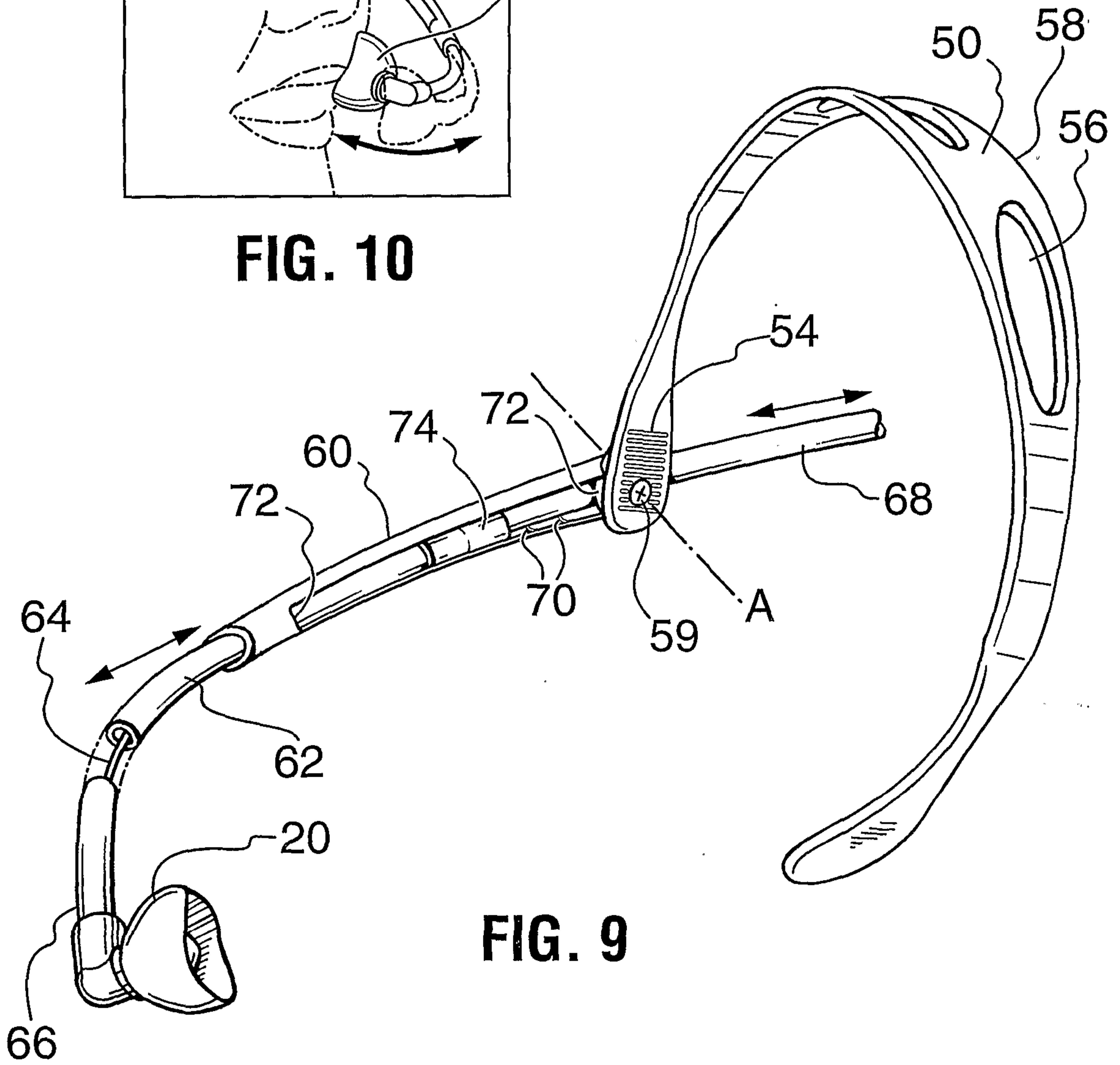
**FIG. 7**



**FIG. 8**

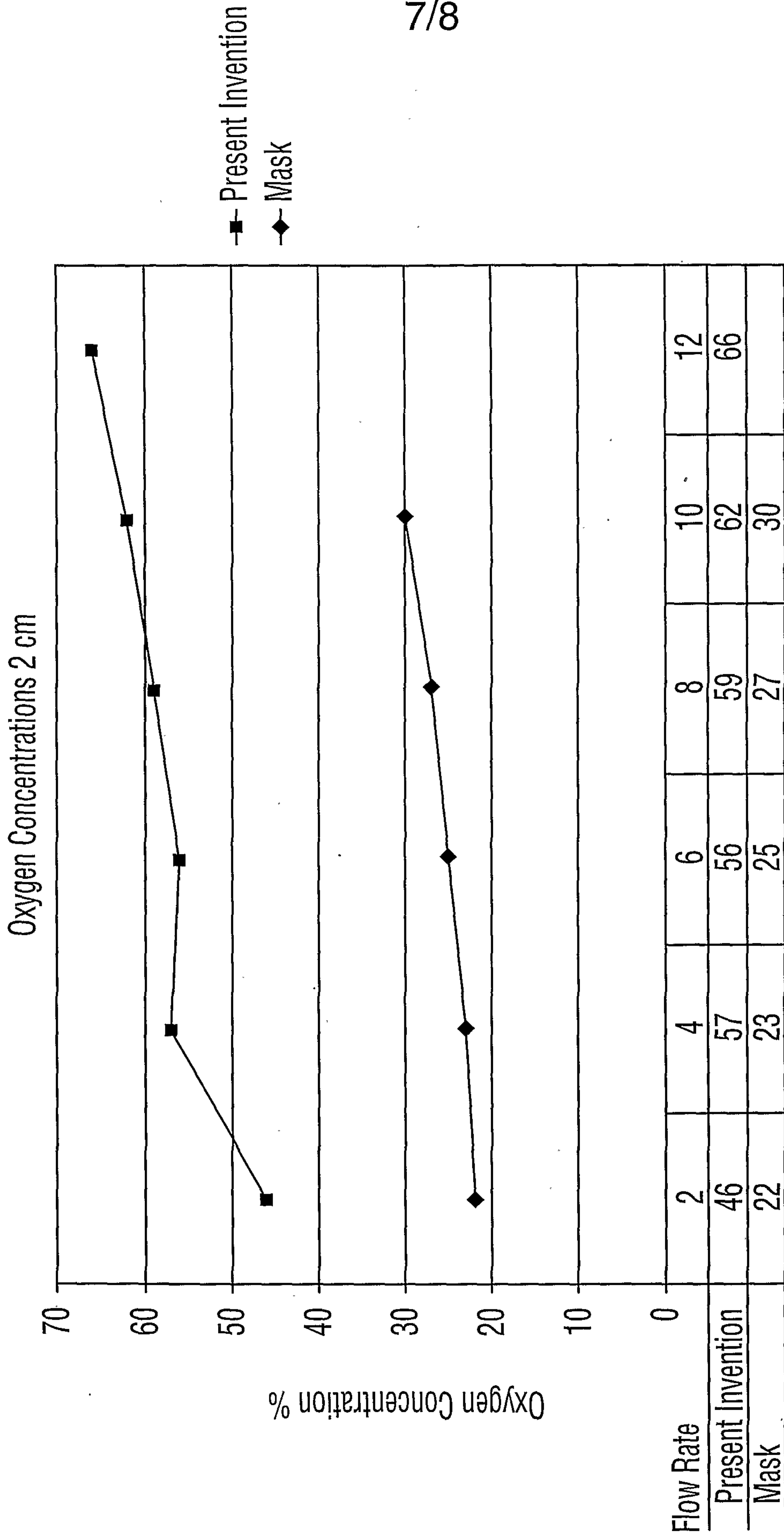


**FIG. 10**



**FIG. 9**

7/8



Flow Rate Setting

**FIG. 11**

8/8

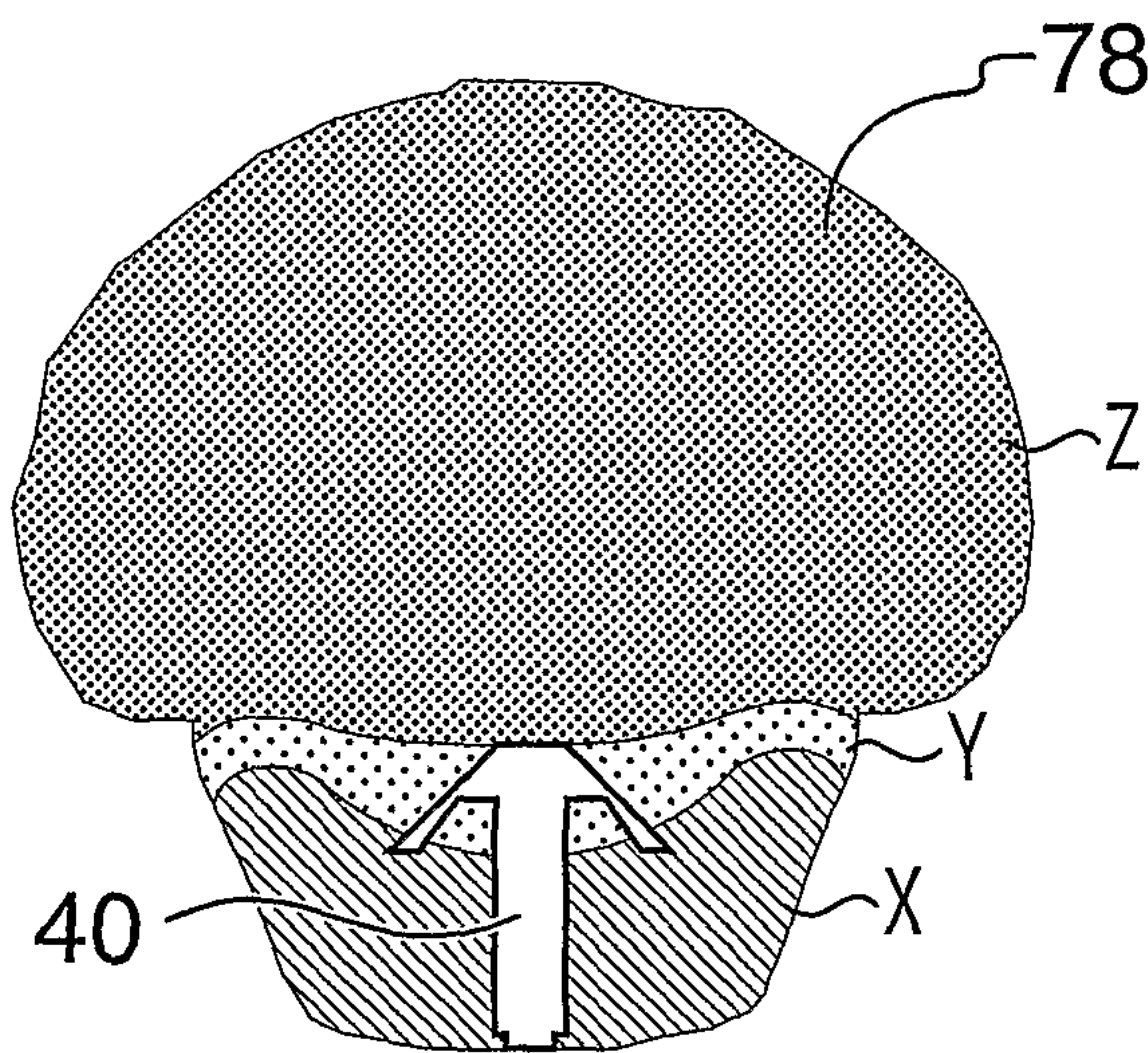


FIG. 12A

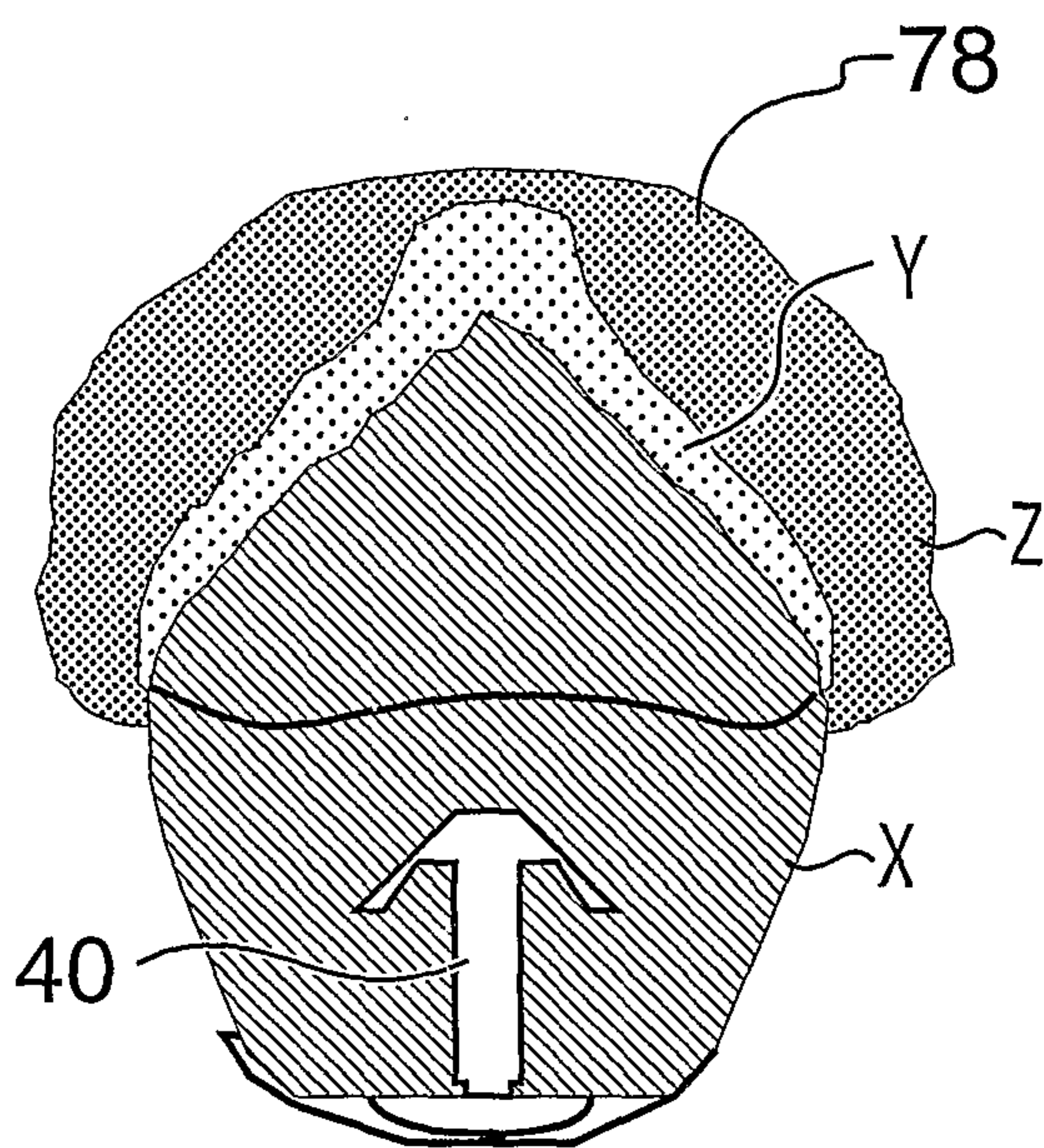


FIG. 12B

