



- (51) **International Patent Classification:**
A61M 16/00 (2006.01)
- (21) **International Application Number:**
PCT/US2012/049715
- (22) **International Filing Date:**
6 August 2012 (06.08.2012)
- (25) **Filing Language:** English
- (26) **Publication Language:** English
- (30) **Priority Data:**
13/229,133 9 September 2011 (09.09.2011) US
- (71) **Applicant (for all designated States except US):** **ALLIED HEALTHCARE PRODUCTS, INC.** [US/US]; 1720 Sublette Avenue, St. Louis, Missouri 63110 (US).
- (72) **Inventors; and**
- (75) **Inventors/Applicants (for US only):** **KROUPA, Kevin** [US/US]; 1720 Sublette Avenue, St. Louis, Missouri 63110 (US). **PALMER, Steve** [US/US]; 1720 Sublette Avenue, St. Louis, Missouri 63110 (US).
- (74) **Agents:** **BAI, Ari** et al.; Polsinelli Shughart PC, 100 South Fourth Street, Suite 1000, St. Louis, Missouri 63102-1825 (US).

- (81) **Designated States (unless otherwise indicated, for every kind of national protection available):** AE, AG, AL, AM, AO, AT, AU, AZ, BA, BB, BG, BH, BN, BR, BW, BY, BZ, CA, CH, CL, CN, CO, CR, CU, CZ, DE, DK, DM, DO, DZ, EC, EE, EG, ES, FI, GB, GD, GE, GH, GM, GT, HN, HR, HU, ID, IL, IN, IS, JP, KE, KG, KM, KN, KP, KR, KZ, LA, LC, LK, LR, LS, LT, LU, LY, MA, MD, ME, MG, MK, MN, MW, MX, MY, MZ, NA, NG, NI, NO, NZ, OM, PE, PG, PH, PL, PT, QA, RO, RS, RU, RW, SC, SD, SE, SG, SK, SL, SM, ST, SV, SY, TH, TJ, TM, TN, TR, TT, TZ, UA, UG, US, UZ, VC, VN, ZA, ZM, ZW.
- (84) **Designated States (unless otherwise indicated, for every kind of regional protection available):** ARIPO (BW, GH, GM, KE, LR, LS, MW, MZ, NA, RW, SD, SL, SZ, TZ, UG, ZM, ZW), Eurasian (AM, AZ, BY, KG, KZ, RU, TJ, TM), European (AL, AT, BE, BG, CH, CY, CZ, DE, DK, EE, ES, FI, FR, GB, GR, HR, HU, IE, IS, IT, LT, LU, LV, MC, MK, MT, NL, NO, PL, PT, RO, RS, SE, SI, SK, SM, TR), OAPI (BF, BJ, CF, CG, CI, CM, GA, GN, GQ, GW, ML, MR, NE, SN, TD, TG).

Published:
— with international search report (Art. 21(3))

(54) **Title:** SHUTTLING BY-PASS COMPRESSOR APPARATUS

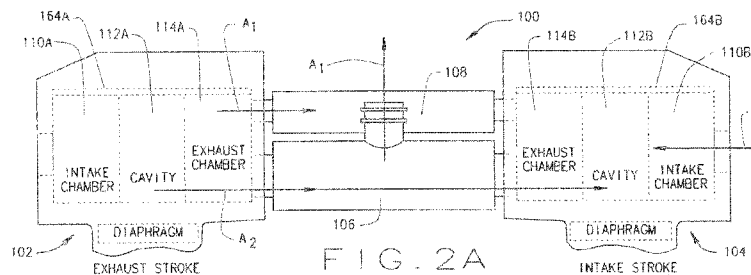

(57) **Abstract:** A compressor apparatus (100) having a first compressor head (102) for generating a first gas flow and a second compressor head (104) for generating a second gas flow with a shuttling by-pass component (108) in fluid flow communication between the first and second compressor heads (102, 104) for allowing the output of a portion of either the first gas flow or the second gas flow to be diverted to the other compressor head (102, 104) is disclosed.

WO 2013/036339 A1

SHUTTLING BY-PASS COMPRESSOR APPARATUS

FIELD

[0001] This document relates to a compressor apparatus for providing compressed gas, and in particular to a shuttling by-pass compressor apparatus used with a ventilator system to achieve steady flow rates using less power.

BACKGROUND

[0002] In medicine, mechanical ventilation is a method to mechanically assist or replace spontaneous breathing of a patient using a machine called a ventilator. The ventilator may include a prior art compressor apparatus that draws in gas and delivers compressed gas to the patient in a controlled manner to meet patient specifications. As shown in FIG. 1, the prior art compressor apparatus **10** may include a pair of compressor heads **12** and **14** that are synchronized to draw in and force out gas in an alternating fashion such that there is a continuous inflow and outflow of gases from the prior art compressor apparatus **10**. In the illustrated embodiment, each of the compressor heads **12** and **14** further includes a respective intake chamber **16A** and **16B** in selective communication with a respective inlet port **18A** and **18B** for the entry of gas, such as air, oxygen or a mixture of gases, which then flows into a respective cavity **17A** and **17B** through a one-way intake valve (not shown). The cavity is configured such that the gas flow from the respective intake chamber **16A** and **16B** can be compressed and forced from the cavity **17A** and **17B** of each compressor head **12** and **14** and into an exhaust chamber **20A** and **20B** through a one-way exhaust valve (not shown), which then allows the compressed gas to exit the compressor heads **12** and **14** through a respective outlet port **22A** and **22B**. The gas is drawn in, compressed, and forced from the cavity through the exhaust valve by a flexible diaphragm or piston (not shown) driven against the cavity in a reciprocating motion that draws in and forces out the gas flow from the cavity for delivery to the patient at a predetermined flow rate through an output connector 24. Although the prior art high flow compressor apparatus has proven satisfactory for its intended purpose, such a compressor apparatus is unable to provide both a steady flow of a small volume of gas at lower flow rates while also being capable of providing a steady flow of a large volume of gas at higher flow rates. Typically, the prior art compressor apparatus **10** cannot achieve steady state flow of gas at flow

rates under 3 liters per minute or the compressor apparatus 10 can stall since the compressor apparatus 10 cannot achieve sufficiently low revolutions per minute by a standard motor used normally for compressor apparatuses 10 that drives each compressor head 12 and 14. In addition, standard compressors are limited in the ratio of minimum flow to maximum flow, which is typically less than 100 to 1. As such, there is a need in the art for a compressor apparatus that permits a steady flow of gases at higher and lower flow rates.

SUMMARY

[0003] In one embodiment, a compressor apparatus may include a first compressor head for generating a first gas flow, a second compressor head in fluid flow communication with the first compressor head for generating a second gas flow, and an output connector in fluid flow communication with the first compressor head and the second compressor head for permitting a continuous alternating output of gas flow by the first compressor head and the second compressor head. The compressor apparatus may also include a shuttling by-pass component in fluid flow communication with the first compressor head and the second compressor head for permitting alternating gas flow between the first compressor head and the second compressor head such that a portion of the first gas flow is diverted from the first compressor head to the second compressor head and a portion of the second gas flow is diverted from the second compressor head to the first compressor head in an alternating sequence.

[0004] In another embodiment, a method for using a compressor apparatus may include:

providing a compressor apparatus including:

a first compressor head for generating a first gas flow;

a second compressor head in fluid flow communication with the second compressor head for generating a second gas flow;

an output connector in fluid flow communication with the first compressor head and the second compressor head for permitting a continuous alternating output of gas flow by the first compressor head and the second compressor head; and

a shuttling by-pass component in fluid flow communication with the first compressor head and the second compressor head for permitting alternating gas flow between the first compressor head and the second compressor head through such that a portion of the first gas flow is diverted from the first compressor head to the second compressor head and a portion of the second gas flow is diverted from the second compressor head to the first compressor head in alternating sequence;

diverting a portion of the first gas flow from the first compressor head to the second compressor head through the shuttling by-pass component; and

diverting a portion of the second gas flow from the second compressor head to the first compressor head through the shuttling by-pass component.

[0005] In yet another embodiment, a method of manufacturing a compressor apparatus may include:

engaging a first compressor head to a second compressor head with an output connector to permit an output of a first gas flow from the first compressor head and an output of a second gas flow from the second compressor head in an alternating sequence;

engaging a shuttling by-pass component between the first compressor head and the second compressor head for establishing fluid flow communication between the first compressor head and the second compressor head to permit a portion of the outputted first gas to flow from the first compressor head to the second compressor head and a portion of the outputted second gas flow to flow from the second compressor head to the first compressor head in alternating sequence; and

operatively engaging a motor with the first compressor head and the second compressor head for driving the first compressor head and the second compressor head in alternating sequence.

[0006] Additional objectives, advantages and novel features will be set forth in the description which follows or will become apparent to those skilled in the art upon examination of the drawings and detailed description which follows.

BRIEF DESCRIPTION OF THE DRAWINGS

[0007] FIG. 1 is a simplified illustration of a prior art compressor head;

[0008] FIG. 2A is a simplified illustration of one embodiment of a compressor apparatus having a shuttling by-pass component illustrating the flow of gas during half of the cycle of operation of the compressor apparatus;

[0009] FIG. 2B is a simplified illustration of the compressor apparatus having the shuttling by-pass component illustrating the flow of gas during the other half of the cycle of operation of the compressor apparatus;

[0010] FIG. 3 is an elevated perspective view of the compressor apparatus;

[0011] FIG. 4 is a front view of the compressor apparatus;

[0012] FIG. 5 is a top view of the compressor apparatus;

[0013] FIG. 6 is a side view of the compressor apparatus;

[0014] FIGS. 7A and 7B are cross-sectional views taken along line 7-7 of FIG. 6 illustrating the shuttling gas flow between a first compressor head and a second compressor head during different portions of the cycle for the compressor apparatus;

[0015] FIG. 8 is an exploded view of the compressor apparatus;

[0016] FIG. 9 is a flow chart illustrating the method of using the compressor apparatus;

[0017] FIG. 10 is a flow chart illustrating the method of manufacturing the compressor head; and

[0018] FIG. 11 is a graph illustrating relative performance of the prior art compressor apparatus with the compressor apparatus having the shuttling by-pass component.

[0019] Corresponding reference characters indicate corresponding elements among the view of the drawings. The headings used in the figures should not be interpreted to limit the scope of the claims.

DETAILED DESCRIPTION

[0020] As described herein, various embodiments of a compressor apparatus having a shuttling by-pass component is configured such that a portion of each gas flow generated by one compressor head is diverted to the other compressor head, and vice versa, through a shuttle component to achieve an efficient steady output of gas at extremely low flow rates. The result is a minimum to maximum flow ratio that is much greater than standard compressor apparatuses.

[0021] Referring to the drawings, various embodiments of the compressor apparatus are illustrated and generally indicated as **100** in FIGS. **2-8**. In one embodiment, the compressor apparatus **100** includes a first compressor head **102** and a second compressor head **104** that operate in alternating sequence of intake strokes, wherein gas is drawn into either the first compressor head **102** or second compressor head **104** and alternating sequence of exhaust strokes, wherein gas is exhausted from either the first compressor head **102** or second compressor head **104** in which first and second half cycles of operation represent one full cycle of operation of the compressor apparatus **100**. For example, in the first half cycle of operation the first compressor head **102** is in the intake stroke, while the second compressor head **104** is in the exhaust stroke. In the second half cycle of operation the first compressor head **102** is in the exhaust stroke, while the second compressor head **104** is in the intake stroke.

[0022] FIGS. **2A** and **2B** illustrate this alternating sequence of operation in which FIG. **2A** illustrates a first half cycle of operation and FIG. **2B** illustrates the second half cycle of operation. As shown in FIG. **2A**, during the first half cycle of operation the first compressor head **102** is in the exhaust stroke and exhausts a first gas flow **A₁**, while the second compressor head **104** is in the intake stroke and simultaneously intakes a second gas flow **B**. Conversely, as shown in FIG. **2B**, during the second half cycle of operation the first compressor head **102** is in the intake stroke and intakes gas flow **A**, while the second compressor head **104** is in the exhaust stroke and simultaneously exhausts gas flow **B**. An output connector **106** is in fluid flow communication with the first compressor head **102** and the second compressor head **104** for permitting a continuous alternating exhaust of a portion of gas flow **A** or **B**, designated **A₁** or **B₁**, generated by the first compressor head **102** or the second compressor head **104**, respectively. In addition, the compressor apparatus **100** includes a shuttling by-pass component **108** that is in fluid flow

communication with the first compressor head **102** and the second compressor head **104** for permitting alternating gas flow directly between the first compressor head **102** and the second compressor head **104** during their respective exhaust strokes such that a portion of the first gas flow **A**, designated **A₂**, is diverted from the first compressor head **102** directly to the second compressor head **104**, while a portion of the second gas flow **B**, designated **B₂**, is then diverted from the second compressor head **104** to the first compressor head **102** during the alternating exhaust strokes of the compressor apparatus **100**. In one embodiment, the first half cycle of operation for the compressor apparatus **100** requires that diverted gas flow **A₂** from the first compressor head **102** flow into the second compressor head **104** through the shuttling by-pass component **108** in one direction, which completes the first half cycle of operation, and then diverted gas flow **B₂** from the second compressor head **104** may flow into the first compressor head **102** in an opposite direction through the shuttling by-pass component **108** during the second half cycle of operation in a continuous alternating sequence of diverted gas flow **A₂** and **B₂**. Since the first compressor head **102** and the second compressor head **104** exhaust gas flows **A₁** or **B₁** from the compressor apparatus **100** in a continuous alternating sequence, the flow of diverted gas flows **A₂** and **B₂** between the first compressor head **102** and the second compressor head **104** follows the same alternating sequence of operation. For example, during the first half cycle of operation diverted gas flow **A₂** is directed from the first compressor head **102** into the second compressor head **104** as the gas flow **A₁** exits the output connector **106**, while gas flow **B** simultaneously enters the second compressor head **104**. Conversely, during the second half cycle of operation the diverted gas flow **B₂** now flows from the second compressor head **104** into the first compressor head **102** as the gas flow **B₁** exits the output connector **106**, while gas flow **A** simultaneously enters the first compressor head **102**. For example, the compressor apparatus **100** has been shown to achieve minimum steady flow rates as low as **0.2** liters per minute, which is far below flow rates that are normally achieved by the conventional compressor apparatuses **10** without the by-pass component **108** for diverting a portion of gas flow from one compressor head **102** or **104** to the other compressor head **102** or **104**. As shall be discussed in greater detail below, comparison tests have been conducted that show that the flow rate ratio of a maximum flow rate to a minimum flow rate is less than **100** to **1** for conventional compressor apparatuses, while a similar test conducted on the

compressor apparatus **100** with the shuttling by-pass component **108** have shown a flow rate ratio of **480** to **1** can be achieved. Moreover, in some embodiments, the compressor apparatus **100** can switch the shuttling by-pass component **108** between operational and non-operational states such that an extremely low flow rate can be achieved when the shuttling by-pass component **108** is made operational, while an extremely high flow rate can be achieved when the shuttling by-pass component **108** is made non-operational by the compressor apparatus **100**. In such embodiments of the compressor apparatus **100**, a flow rate ratio of over **800** to **1** has been achieved.

[0023] Referring to FIGS. **3-6**, one embodiment of the compressor apparatus **100** may include the first compressor head **102** and the second compressor head **104** in fluid flow communication with an intake connector **106A** for allowing the entry of gas flows **A** or **B** during the respective intake strokes and an output connector **106B** gas flows **A₁** or **B₁** during the respective exhaust strokes for delivery to a patient through a ventilator (not shown). FIG. **7A** and **7B**, illustrate the various flow pathways through the compressor apparatus **100** in which the first compressor head **102** and the second compressor head **104** operate in alternating intake and exhaust strokes during completion of a full cycle of operation. In the first half cycle of operation undertaken by the compressor apparatus **100** shown in FIG. **7A**, the first compressor head **102** draws in gas flow **A** into the first compressor head **102** during its respective intake stroke, while the second compressor head **104** simultaneously exhausts out gas flow **B₁** through the output connector **107** and diverts a portion of gas flow **B₁**, designated gas flow **B₂**, through the shuttling by-pass component **108** to the first compressor head **102** during its respective exhaust stroke. Conversely, during the second half cycle of operation by the compressor apparatus **100** shown in FIG. **7B**, the first compressor head **102** exhausts out gas flow **A** through the output connector **106** during its respective exhaust stroke while simultaneously diverting a portion of gas flow **A₁**, designated gas flow **A₂**, through the shuttling by-pass component **108** in a direction opposite to that taken by the diverted gas flow **B₂** to the second compressor head **104** as the second compressor head **104** simultaneously draws in gas flow **B** during its respective intake stroke. As such, the compressor apparatus **100** completes a full cycle of operation when the first compressor head **102** and second compressor head **104** have alternately drawn in respective gas flows **A** or **B** and then forced out respective gas flows **A₁**, **A₂** or **B₁**,

B₂ in alternating fashion through the shuttling by-pass component **108** or the output connector **107** to complete an intake stroke and an exhaust stroke, respectively.

[0024] Referring to FIG. 8, the structural elements of the compressor apparatus **100** and their operation will be discussed in greater detail. In one embodiment, the first compressor head **102** is substantially similar in structure and operation as the second compressor head **104** with the exception that the first compressor head **102** operates in alternating sequence relative to the second compressor head **104** to complete a full cycle of operation for the compressor apparatus **100**. A motor **116** is provided to operate the first compressor head **102** and the second compressor head **104**. In particular, the motor **116** includes a first rotatable shaft **144** for operating the first compressor head **102** and a second rotatable shaft **146** for operating the second compressor head **104**.

[0025] As shown, the first compressor head **102** includes a pump casing **124A** defining a chamber **134A** having an arrangement of a connecting rod **128A** engaged to an eccentric mass **130A** and counterweight **132A** disposed therein. The bottom portion of the connecting rod **128A** is engaged to the eccentric mass **130A** and counterweight **132A**, while the top portion of the connecting rod **128A** is engaged to a flexible diaphragm **126A** through a set screw **162A**. Moreover, the bottom portion of the connecting rod **128A** is engaged to the rotatable shaft **144** of the motor **116** for moving the connecting rod **128A** in an eccentric motion. In operation, the eccentric movement of the connecting rod **128A** by the motor **116** moves the diaphragm **126A** in a reciprocating motion. An adaptor plate **136A** may engage one end of the motor **116** to the pump casing **124A**.

[0026] In one embodiment, the top portion of the pump casing **124** is engaged to the bottom portion of a compressor head housing **118A**, while the top head of the compressor head housing **118A** is engaged to a cover head **138A**. The compressor head housing **118A** includes an inlet **140A** that communicates with the intake chamber **110A** for permitting the gas flow **A** to enter therein. The intake chamber **110A** is in fluid flow communication with the cavity **112A** through a plurality of one-way intake valves **120A** that permit the inflow of gas into the cavity **112A** from the intake chamber **110A**, but prevents retrograde gas flow back into the intake chamber **110A**. In addition, the cavity **112A** is in fluid flow communication with the exhaust chamber **122A** through a plurality of one-way exhaust valves **122A** that permit the inflow of gas into the exhaust chamber **114A** from the cavity **112A**, but

prevents retrograde gas flow back into the cavity **112A**. The cavity **112A** is configured to act in concert with the reciprocating diaphragm **126A** such that movement of the diaphragm **126A** from the cavity **112A** during one-half cycle causes gas flow into the cavity **112A** from the intake chamber **110A**, while movement of the diaphragm **126A** toward the cavity **112A** during the other half-cycle causes the gas to become compressed and flow from the cavity **112A** and into the exhaust chamber **114A** such that the compressed gas exits the outlet connector **107** through the outlet **142A** of the compressor head housing **118A**.

[0027] Similar to the first compressor head **102**, the second compressor head **104** includes a pump casing **124B** defining a chamber **134B** having an arrangement of a connecting rod **128B** engaged to an eccentric mass **130B** and counterweight **132B** disposed therein. The bottom portion of the connecting rod **128B** is engaged to the eccentric mass **130B** and counterweight **132B**, while the top portion of the connecting rod **128B** is engaged to a flexible diaphragm **126B** through a set screw **162B**. Moreover, the bottom portion of the connecting rod **128B** is engaged to the rotatable shaft **144** of the motor **116** for moving the connecting rod **128B** in an eccentric motion. In operation, the eccentric movement of the connecting rod **128B** by the motor **116** moves the diaphragm **126B** in a reciprocating motion. An adaptor plate **136B** may engage one end of the motor **116** to the pump casing **124B**.

[0028] In one embodiment, the top portion of the pump casing **124** is engaged to the bottom portion of a compressor head housing **118B**, while the top head of the compressor head housing **118B** is engaged to a cover head **138A**. The compressor head housing **118B** includes an inlet **140B** that communicates with the intake chamber **110B** for permitting the gas flow **B** to enter therein. The intake chamber **110B** is in fluid flow communication with the cavity **112B** through a plurality of one-way intake valves **120B** that permit the inflow of gas into the cavity **112B** from the intake chamber **110B**, but prevents retrograde gas flow back into the intake chamber **110B**. In addition, the cavity **112B** is in fluid flow communication with the exhaust chamber **122B** through a plurality of one-way exhaust valves **122B** that permit the inflow of gas into the exhaust chamber **114B** from the cavity **112B**, but prevents retrograde gas flow back into the cavity **112B**. The cavity **112B** is configured to act in concert with the reciprocating diaphragm **126B** such that movement of the diaphragm **126B** from the cavity **112B** during first half cycle causes gas flow into the cavity **112B** from the intake chamber **110B**, while movement of the

diaphragm **126B** toward the cavity **112B** during the second half cycle causes the gas to become compressed and flow from the cavity **112B** and into the exhaust chamber **114B** such that the compressed gas exits the outlet connector **106B** through the outlet **142B** of the compressor head housing **118B**.

[0029] As further shown, the shuttling by-pass component **108** may be an elongated hollow shaft that permits two-way gas flow between the first compressor head **102** and the second compressor head **104** when diverted gas flow **A₂** and diverted gas flow **B₂** alternately flow between the compressor heads **102** and **104**. The shuttling by-pass component **108** defines one end that engages a by-pass fitting **148A** for coupling the shuttling by-pass component **108** to the cover head **138A** of the first compressor head **102** and an opposite end that engages another by-pass fitting **148B** for coupling the shuttling by-pass component **108** to the second compressor head **104**. Sealing elements **158A**, such as O-rings, provide a fluid-tight seal between the cover head **138A** and the by-pass fitting **148A**, while sealing elements **158B** provide a fluid-tight seal between the cover head **138B** and the by-pass fitting **148B**. In one embodiment, the by-pass fitting **148B** is operatively engaged to a solenoid **150** through a by-pass seat **152** having a spring **154**. The spring **154** applies a bias for permitting or preventing fluid flow communication through an orifice **149** formed by the cover head **138B**, which is configured to engage the by-pass seat **152** by action of the solenoid **150** which opens and closes the orifice **149** to diverted gas flow **A₂** or **B₂**. As such, the presence of the shuttling by-pass component **108** allows for the compressor apparatus **100** to achieve extremely lower and steadier flow rates in comparison to the flow rates achievable by the conventional compressor apparatus **10** without the by-pass component **108**.

[0030] In operation, the solenoid **150** opens the by-pass seat **152** during the exhaust stroke of the first compressor head **102** to permit diverted gas flow **A₂** to flow from the first compressor head **102** to the second compressor head **104** during first half of cycle of operation. Similarly, the solenoid **150** opens the by-pass seat **152** during the exhaust stroke of the second compressor head **104** to permit diverted gas flow **B₂** to flow from the second compressor head **104** to the first compressor head **102** during the second half cycle of operation in order to complete a full cycle of operation by the compressor apparatus **100**. In some components, the orifice size of the shuttling by-pass component **108** may be tailored to achieve a particular flow rate by the compressor apparatus **100** by diverting a specific amount of diverted gas flow

from each of the first and second compressor heads **102** and **104**. In other embodiments, the shuttling by-pass component **108** may include a variable orifice (not shown) that provides a variable-sized opening for varying the degree of diverted gas flow **A₂** or **B₂** permitted to flow through the shuttling by-pass component **108** to the other compressor head **102** or **104** in order to provide flow adjustment capability. In this manner, the amount of diverted gas flow **A₂** and **B₂** may be adjusted for achieving different degrees of low flow rates by the compressor apparatus **100**.

[0031] In some embodiments, the shuttling by-pass component **108** may be a screw drive or rotary actuator that may be used to open the orifice **149** as a substitute for the solenoid **150**.

[0032] The advantages of incorporating the shuttling by-pass component **108** into the compressor apparatus **100** is that it lowers the potential steady flow rate attainable by the compressor apparatus **100** by diverting a portion of the gas flow from one compressor head during its exhaust cycle to the other compressor head during its intake cycle, and vice versa, as one full cycle of operation of the compressor apparatus **100** is completed. For example, the compressor apparatus **100** with the shuttling by-pass component **108** can achieve an extremely low flow rate, such as **0.1** liters per minute, when about **97%** (based on an **80+** liters per minute of compressor apparatus **100** capacity) of the exhausted gas flow is diverted to the other compressor head and vice versa. This results in a maximum to minimum flow ratio of **800** to **1**. The same bypass function may be applied to other compressors with varying capacity to achieve either higher or lower bypass flow rates.

[0033] In some embodiments, the shuttling by-pass component **108** may be incorporated into the compressor apparatus **100** having a motor with a fixed power source as an after market modification, which may be used as a means of achieving flow adjustment for the compressor apparatus by varying the amount of gas flow that may be diverted through the shuttling by-pass component **108**.

[0034] Referring to FIG. **9**, a flow chart illustrates one method of using the compressor apparatus **100**. At block **200**, a compressor apparatus **100** is provided having a first compressor head **102** in fluid flow communication with a second compressor head **104** through an output connector **106** and then engaging a shuttling by-pass component **108** in fluid flow communication between the first compressor head **102** and the second compressor head **104**. At block **202**, the

compressor apparatus **100** is engaged to a ventilator system for providing gas flow to the first compressor head **102** and the second compressor head **104**. At block **204**, the compressor apparatus **100** is actuated such that the first compressor head **102** generates a first gas flow during a first exhaust stroke of the first compressor head **102** and the second compressor head **104** generates a second gas flow during an alternating second exhaust stroke of the second compressor head **104**. At block **206**, a portion of the first gas flow is allowed to flow from the first compressor head **102** and into the second compressor head **104** through the shuttling by-pass component **108** during the first exhaust stroke of the first compressor head **102** and then allowing a portion of the alternating second gas flow from the second compressor head **104** to flow through the shuttling by-pass component **108** and into the first compressor head **102** during an alternating second exhaust stroke of the second compressor head **104**.

[0035] Referring to FIG. **10**, a flow chart illustrates one method of manufacturing the compressor apparatus **100**. At block **300**, the first compressor head **102** is engaged to the second compressor head **104** through an output connector **106** to permit exhaust of a gas flow from the first compressor head **102** and the second compressor head **104** in alternating sequence. At block **302**, a shuttling by-pass component **108** is engaged between the first compressor head **102** and the second compressor head **104** for establishing fluid flow communication between the first compressor head **102** and the second compressor head **104** to permit a portion of the exhausted gas flow from either the first compressor head **102** or the second compressor head **104** to be diverted to the other respective compressor head **102** or **104**. This allows the compressor apparatus **100** to achieve a much lower and steadier flow rate using less power than would otherwise be required by a compressor apparatus **10** without the shuttling by-pass component **108**. At block **304**, a motor **116** is operatively engaged with the first compressor head **102** and the second compressor head **104** for driving the first compressor head **102** and the second compressor head **104** in alternating sequence.

[0036] The compressor apparatus **100** with the shuttling by-pass component **108** may have applications outside the medical field described herein. For example, the compressor apparatus **100** may be used in heating and air conditioning applications as well as refrigeration industries where multi-speed compressors are commonly used.

Test Results

[0037] Two different tests were conducted to demonstrate the superior performance of the compressor apparatus **100** with the shuttling by-pass component **108** in comparison with the prior art standard compressor apparatuses **10** without the shuttling by-pass component **108**. The first test was directed to comparing minimum/maximum flow rate ratios exhibited by the standard compressor apparatuses **10** relative to the compressor apparatus **100** and the second test was directed to comparing the variance in flow rate between a standard compressor apparatus **10** and the compressor apparatus **100** with the shuttling by-pass component **108**. With respect to the first test, tables **1-5** below provide test results that compare the maximum/minimum flow rate ratio achieved by the compressor apparatus **100** with the shuttling by-pass component **108** (Table **5**) with the maximum/minimum flow rate ratios achieved by four prior art standard compressor apparatuses **10** without the shuttling by-pass component **108** (Tables **1-4**). As shown, table **1** represents a standard compressor apparatus **10** without the shuttling by-pass component **108** manufactured under the product name GAST 15D, which exhibits a minimum flow rate of **0.2** liters per minute at a voltage setting of **2** volts and a maximum flow rate of **17.1** liters per minute at a voltage setting of **12** volts.

GAST 15D

PUMP WEIGHT: 1.54 LBS

VDC	LPM
0	0
1	0
2	0.2
3	0.4
4	1.7
5	4.4
6	6.7
7	8.5
8	10.8
9	12.5
10	13.7
11	15.6
12	17.1

TABLE 1

T SQUARED

PUMP WEIGHT: 3.82 LBS

VDC	LPM
0	0
1	5.1
2	11.3
3	18.4
4	25.9
5	32.5
6	39.6
7	46.6
8	53.8
9	60.9
10	68.2
11	75.1
12	82.3

TABLE 2

KNF

PUMP WEIGHT: 6.64 LBS

POT SETTING

VDC	LPM
0	0
1	31.1
2	58.7
3	69.6
4	72.7
5	73.8
6	73.8
7	73.8
8	73.8

TABLE 3

POWEREX
ANEST IWATA
PUMP WEIGHT: 2.74 LB

VOLTAGE SETTING	LPM
1.7	1.3
1.8	5.4
1.9	8.8
2	12.6
2.2	18.9
2.4	24.9
2.6	30.8
2.8	37.2
3	43.3
3.2	49.4
3.4	55.1
3.6	60.7
3.8	66.5
4	71.6
4.2	76.9
4.4	79.3
4.6	79.3

TABLE 4

ALLIED
 PUMP 1
 WEIGHT: 4.44 LB

VDC	FULL FLOW	BYPASS
	LPM	FLOW LPM
1	3.1	0.1
2	10.3	0.3
3	17.7	0.8
4	22.4	5.1
5	33.8	10.6
6	40.7	13.6
7	45.8	18.7
8	55.4	24.1
9	63.1	31.2
10	69.3	37.1
11	76.4	43.2
12	83.5	48.1

TABLE 5

[0038] Table 2 represents another standard compressor apparatus 10 without the shuttling by-pass component 108 manufactured under the product name T-Squared, which exhibits a minimum flow rate of 5.1 liters per minute at a voltage setting of 1 volt and a maximum flow rate of 82.3 liters per minute at a voltage setting of 12 volts. Table 3 represents another standard compressor apparatus 10 without the shuttling by-pass component 108 manufactured under the product name KNF, which exhibits a minimum flow rate of 31.1 liters per minute at a voltage setting of 1 volt and a maximum flow rate of 73.8 liters per minute at a voltage setting of 8 volts. Table 4 represents yet another standard compressor apparatus 10 without the shuttling by-pass component 108 manufactured under the product name Powerex, which exhibits a minimum flow rate of 1.3 liters per minute at a voltage setting of 1.7 volts. Finally, table 5 represents a compressor apparatus 100 with the shuttling by-pass component 108 manufactured by the Applicants, which exhibits a minimum flow rate of 0.1 liters per minute at a voltage setting of 1 volt and a maximum flow rate of 48.1 liters per minute at a voltage setting of 12 volts when the shuttling by-pass component 108 is made operational, while the compressor apparatus 100 exhibits a minimum flow rate of 3.1 liters per minute at a voltage setting of 1 volt and a

maximum flow rate of **83.5** liters per minute when the shuttling by-pass component **108** is made non-operational. As noted above, the compressor apparatus **100** with the shuttling by-pass component **108** can operate to make the shuttling by-pass component **108** operational at times to achieve any extremely low flow rate, while making the shuttling by-pass component **108** non-operational at times to achieve an extremely high flow rate. Table **6** shows the minimum flow rate, maximum flow rate, and the output flow ratios (maximum flow rate/minimum flow rate) for each of the aforementioned compressor apparatuses **10** without the shuttling by-pass component **108** in comparison with the compressor apparatus **100** having the shuttling by-pass component **108**.

	GAST 15D	T SQUARED	KNF	POWEREX ANEST IWATA	ALLIED
Compressor Type	Standard	Standard	Standard	Standard	By-Pass
Minimum Flow	0.2	5.1	31.1	1.3	0.1
Maximum Flow	17.1	82.3	73.8	79.3	83.5
Output Flow Ratio (Max Flow / Min Flow)	85.5	16.1	2.4	61.0	835.0

TABLE 6

[0039] As shown in table **6**, the flow rate ratio of the compressor apparatus **100** with the shuttling by-pass component **108** is almost ten times the flow rate ratio of the closest standard compressor apparatus **10** without the shuttling by-pass component **108**. For example, the flow rate ratio of the GAST 15D compressor apparatus **10** without the shuttling by-pass component **108** of table **1** is **85.5 to 1**, the flow rate ratio of the T-Squared compressor apparatus **10** without the shuttling by-pass component **108** of table **2** is **16.1 to 1**, the flow rate ratio of the KNF compressor apparatus **10** without the shuttling by-pass component **108** of table **3** is **2.4 to 1**, and the flow rate ratio of the Powerex compressor apparatus **10** without the shuttling by-pass component **108** of table **4** is **61.0 to 1**. In contrast, the flow rate ratio of the compressor apparatus **100** when the shuttling by-pass component **108** is made operational is **481 to 1**, while an even higher flow rate ratio of **836 to 1** can be achieved when the compressor apparatus **100** switches the shuttling by-pass component **108** between operational mode to achieve a low flow rate of **0.1** liters per minute and the non-operational mode to achieve a high flow rate of **83.5** liters per minute as illustrated in FIG. **5**. The test results clearly show that the compressor

apparatus **100** with the shuttling by-pass component **108** has a far greater ratio of maximum flow rate to the minimum flow rate, thereby exhibiting much greater range of flow rates than is achievable by the prior art standard compressor apparatuses **10** without the by-pass component **108** under similar operating conditions. It should be noted that although the voltage settings of the KNF and Powerex compressor apparatuses **10** are between **1-8** volts and **1.7-4.6** volts, respectively, rather than the normal voltage setting range of **1-12** volts used for the other compressor apparatuses **10** and the compressor apparatus **100** during the tests, these smaller voltage setting ranges for the KNF and Powerex compressor apparatuses **10** are due to the smaller operational voltage settings for operating these particular compressor apparatuses **10** at their equivalent full operational range to obtain both comparable minimum and maximum flow rates.

[0040] Table **7** shows the results of the second test for comparing the variance in flow rate, referred to as pulsations, for a standard compressor apparatus **10** as compared with the compressor apparatus **100** having the shuttling by-pass component **108** at the same flow rate of **10** liters per minute. Minimizing the flow rate pulsations or the variance in flow rate by the compressor apparatus when maintaining a particular flow rate is important since a large variance in flow rate can be felt by a patient connected to a ventilator when the compressor apparatus exhibits a high variance in flow rate when maintaining a particular flow rate. The graph illustrated in FIG. **11** and the test results between the two types of compressor apparatuses **10** and **100** of table **7** clearly show that the compressor apparatus **100** with the shuttling by-pass component **108** demonstrates a much lower variance in flow rate when maintaining a flow rate of **10** liters per minute than the standard compressor apparatus **10** without the shuttling by-pass component **108** when maintaining the same **10** liters per minute flow rate. As shown, the flow rate variance in maintaining a flow rate of **10** liters per minute exhibited by the standard compressor apparatus **10** without the shuttling by-pass component **108** is about **4.7** liters per minute, while the variance in maintaining the same **10** liters per minute flow rate exhibited by the compressor apparatus **100** with the shuttling by-pass component **108** is about **2.0** liters per minute. As such, the standard compressor apparatus **10** without the shuttling by-pass components **108** exhibits a variance in flow rate about **2.5** times larger than the variance in flow rate for the compressor

apparatus **100** with the shuttling by-pass component **108**. Table **7** showing the test data illustrated in the graph of FIG. **11** is set forth below.

Date--Time: Wed, Jun 15, 2011--
1:58:43 PM

Channel 1		TIME	FLOW
TIME	LPM STP		
0	10.15	0	9.65
0.0625	9.35	0.05	10.191
0.125	9.91	0.1	7.947
0.1875	9.91	0.15	8.368
0.25	9.88	0.2	8.225
0.3125	10.41	0.25	9.831
0.375	9.96	0.3	11.172
0.4375	9.96	0.35	11.377
0.5	9.26	0.4	10.701
0.5625	10.45	0.45	9.65
0.625	8.97	0.5	8.599
0.6875	8.97	0.55	8.008
0.75	10.25	0.6	8.853
0.8125	10.05	0.65	10.508
0.875	10.35	0.7	11.498
0.9375	10.35	0.75	11.969
1	9.64	0.8	11.728
1.0625	9.27	0.85	10.423
1.125	10.05	0.9	9.131
1.1875	10.05	0.95	8.756
1.25	8.91	1	9.892
1.3125	10.01	1.05	11.402
1.375	9.26	1.1	12.09
1.4375	9.26	1.15	11.981
1.5	9.9	1.2	11.426
1.5625	9.44	1.25	10.17
1.625	9.38	1.3	9.203
1.6875	9.38	1.35	8.865
1.75	9.54	1.4	9.928
1.8125	9.69	1.45	11.365
1.875	8.88	1.5	12.295
1.9375	8.88	1.55	12.549
2	10.25	1.6	11.788
2.0625	9.65	1.65	10.194
2.125	10.42	1.7	9.312
2.1875	10.42	1.75	9.264
2.25	9.7	1.8	10.459
2.3125	9.02	1.85	11.679
2.375	9.85	1.9	12.042
2.4375	9.85	1.95	11.873

2.5	8.95	2	11.003
2.5625	10.15	2.05	9.59
2.625	8.98	2.1	8.744
2.6875	8.98	2.15	8.95
2.75	9.73	2.2	10.266
2.8125	9.96	2.25	11.776
2.875	9.55	2.3	12.573
2.9375	9.55	2.35	12.368
3	9.17	2.4	11.317
3.0625	9.46	2.45	9.856
3.125	9.51	2.5	9.034
3.1875	9.51	2.55	9.517
3.25	10.2	2.6	10.943
3.3125	9.13	2.65	11.981
3.375	10.57	2.7	12.271
3.4375	10.57	2.75	11.679
3.5	9.94	2.8	10.363
3.5625	8.89	2.85	9.215
3.625	9.65	2.9	8.72
3.6875	9.65	2.95	9.602
3.75	8.94	3	11.172
3.8125	9.95	3.05	12.295
3.875	9.76	3.1	12.585
3.9375	9.76	3.15	12.078
4	9.66	3.2	10.749
4.0625	9.67	3.25	9.505
4.125	9.78	3.3	9.058
4.1875	9.78	3.35	10.085
4.25	9.18	3.4	11.522
4.3125	10.18	3.45	12.223
4.375	9.55	3.5	12.138
4.4375	10.27	3.55	11.595
4.5	10.27	3.6	10.218
4.5625	9.94	3.65	9.143
4.625	10.48	3.7	8.817
4.6875	9.84	3.75	10.013
4.75	9.84	3.8	11.462
4.8125	9.07	3.85	12.162
4.875	10.28	3.9	12.368
4.9375	8.88	3.95	11.522
5	8.88	4	10.109
5.0625	10.13	4.05	9.095
5.125	10	4.1	9.143
5.1875	10.36	4.15	10.484
5.25	10.36	4.2	11.583
5.3125	10.05	4.25	12.054

5.375	9.27	4.3	11.836
5.4375	9.78	4.35	11.184
5.5	9.78	4.4	10.013
5.5625	9.98	4.45	9.095
5.625	9.52	4.5	9.372
5.6875	10.12	4.55	10.846
5.75	10.12	4.6	12.078
5.8125	9.35	4.65	12.658
5.875	9.15	4.7	12.67
5.9375	9.64	4.75	11.365
6	9.64	4.8	9.976
6.0625	9.01	4.85	9.131
6.125	10.3	4.9	9.783
6.1875	8.6	4.95	11.232
6.25	8.6	5	12.199
6.3125	10.59	5.05	12.078
6.375	9.85	5.1	11.51
6.4375	10	5.15	10.363
6.5	10	5.2	9.348
6.5625	9.69	5.25	8.829
6.625	8.89	5.3	9.578
6.6875	9.8	5.35	11.027
6.75	9.8	5.4	12.283
6.8125	8.49	5.45	12.609
6.875	9.94	5.5	12.332
6.9375	8.97	5.55	11.075
7	8.97	5.6	9.638
7.0625	9.94	5.65	9.083
7.125	9.81	5.7	10.061
7.1875	9.65	5.75	11.438
7.25	9.65	5.8	12.078
7.3125	9.84	5.85	11.788
7.375	9.77	5.9	11.341
7.4375	9.32	5.95	10.278
7.5	9.81	6	9.191
7.5625	9.81	6.05	8.781
7.625	9.98	6.1	9.819
7.6875	9.44	6.15	11.184
7.75	9.64	6.2	12.271
7.8125	9.64	6.25	12.597
7.875	9.25	6.3	11.812
7.9375	9.44	6.35	10.206
8	9.03	6.4	9.119
8.0625	9.03	6.45	9.107
8.125	10.07	6.5	10.423
8.1875	9.93	6.55	11.426

8.25	10.29	6.6	11.909
8.3125	10.29	6.65	11.764
8.375	9.42	6.7	11.027
8.4375	8.84	6.75	9.735
8.5	10.07	6.8	8.913
8.5625	10.07	6.85	9.107
8.625	8.48	6.9	10.496
8.6875	10.15	6.95	11.836
8.75	9.34	7	12.15
8.8125	9.34	7.05	11.933
8.875	9.77	7.1	10.882
8.9375	9.84	7.15	9.662
9	9.7	7.2	8.926
9.0625	9.7	7.25	9.542
9.125	9.9	7.3	10.991
9.1875	9.71	7.35	12.066
9.25	9.34	7.4	12.102
9.3125	9.34	7.45	11.45
9.375	10.33	7.5	10.411
9.4375	9.52	7.55	9.312
9.5	10.49	7.6	8.684
9.5625	10.49	7.65	9.445
9.625	10.01	7.7	11.015
9.6875	8.48	7.75	12.15
9.75	9.96	7.8	12.259
9.8125	9.96	7.85	12.005
9.875	8.89	7.9	10.556
9.9375	10.3	7.95	9.312
10	8.83	8	8.865

TABLE 7

[0041] It should be understood from the foregoing that, while particular embodiments have been illustrated and described, various modifications can be made thereto without departing from the spirit and scope of the invention as will be apparent to those skilled in the art. Such changes and modifications are within the scope and teachings of this invention as defined in the claims appended hereto.

CLAIMS

What is claimed is:

1. A compressor apparatus **(100)** comprising:
 - a first compressor head **(102)** for generating a first gas flow;
 - a second compressor head **(104)** in fluid flow communication with the first compressor head **(102)** for generating a second gas flow;
 - an output connector **(106)** in fluid flow communication with the first compressor head **(102)** and the second compressor head **(104)** for permitting a continuous alternating output of the first gas flow and the second gas flow by the first compressor head **(102)** and the second compressor head **(104)**, respectively; and
 - a shuttling by-pass component **(108)** in fluid flow communication with the first compressor head **(102)** and the second compressor head **(104)** for permitting alternating gas flow between the first compressor head **(102)** and the second compressor head **(104)** such that a portion of the first gas flow is diverted from the first compressor head **(102)** to the second compressor head **(104)** and a portion of the second gas flow is diverted from the second compressor head **(104)** to the first compressor head **(102)** in alternating sequence.
2. The compressor apparatus **(100)** of claim 1, wherein the portion of the first gas flow diverted from the first compressor head **(102)** to the second compressor head **(104)**, and vice versa, flows through the shuttling by-pass component **(108)** flows through a respective by-pass connector **(148A, 148B)** that is in fluid flow communication between the first compressor head **(102)** and the second compressor head **(104)**.
3. The compressor apparatus **(100)** of claim 2, wherein the portion of the second gas flow diverted from the second compressor head **(104)** to the first compressor head **(102)** through the by-pass component **(148A, 148B)** flows through the shuttling by-pass connector **(108)** that is in fluid flow communication between the first compressor head **(102)** and the second compressor head **(104)**.

4. The compressor apparatus **(100)** of claim 1, wherein the first compressor head **(102)** operates in a first intake stroke to draw in the first gas flow and an alternating first exhaust stroke to output the first gas flow while the second compressor head **(104)** operates in a second intake stroke to draw in the second gas flow and an alternating second exhaust stroke to output the second gas flow, wherein when the first compressor head **(102)** is in the first intake stroke the second compressor head **(104)** is simultaneously in the second exhaust stroke and wherein when the first compressor head **(102)** is in the first exhaust stroke the second compressor head **(104)** is simultaneously in the second intake stroke.
5. The compressor apparatus **(100)** of claim 1, wherein the shuttling by-pass component **(108)** includes a by-pass orifice **(149)** for permitting the flow of either the diverted first gas flow or the diverted second gas flow when the by-pass orifice **(149)** is in the open position and preventing the flow of either the diverted first gas flow or the diverted second gas flow when the by-pass orifice is in the closed position.
6. The compressor apparatus **(100)** of claim 5, wherein the by-pass orifice **(149)** is a solenoid **(150)** having a spring-loaded seat **(152)** the permits or prevents gas flow of either the diverted first gas flow or diverted second gas flow through the shuttling by-pass connector **(108)** by the by-pass orifice **(149)**.
7. The compressor apparatus **(100)** of claim 4, wherein the first compressor head **(102)** and the second compressor head **(104)** each comprise:
 - an inlet port **(140A, 140B)** in fluid flow communication with an intake chamber **(110A, 110B)** for allowing the entry of the gas flow therein;
 - at least one intake valve **(120A, 120B)** in communication with the intake chamber **(110A, 110B)** and a cavity **(112A, 112B)** for permitting the gas flow to flow from the intake chamber **(110A, 110B)** and into the cavity **(112A, 112B)** during a respective first and second intake strokes;
 - at least one exhaust valve **(122A, 122B)** in communication with the cavity **(112A, 112B)** and an exhaust chamber **(114A, 114B)** for

permitting the gas flow to flow from the cavity **(112A, 112B)** and into the exhaust chamber **(114A, 114B)** during a respective first and second exhaust strokes;

a flexible diaphragm **(126A, 126B)** configured to be driven against the cavity **(112A, 112B)** in a reciprocating motion for drawing in the gas flow into the cavity **(112A, 112B)** in one motion of the flexible diaphragm **(126A, 126B)** during the respective first or second intake strokes and forcing gas out of the cavity **(112A, 112B)** in an opposite motion of the flexible diaphragm **(126A, 126B)** during the respective first or second exhaust strokes; and

an outlet port **(142A, 142B)** in fluid flow communication with the exhaust chamber **(114A, 114B)** for permitting the gas flow to exit from the exhaust chamber **(114A, 114B)** during the respective first and second exhaust strokes.

8. The compressor apparatus **(100)** of claim 1, wherein the compressor apparatus **(100)** achieves a minimum flow rate of about 0.1 liters per minute.
9. The compressor apparatus **(100)** of claim 1, wherein the compressor apparatus **(100)** achieves a variance in flow rate about 2.5 times less than another compressor apparatus **(100)** without the shuttling by-pass component **(108)**.
10. The compressor apparatus **(100)** of claim 1, wherein a flow rate ratio of a maximum flow rate to a minimum flow rate for the compressor apparatus **(100)** is over 800 to 1.
11. The compressor apparatus **(100)** of claim 4, wherein when the first compressor head **(102)** is in the exhaust stroke the portion of the first gas flow is diverted from the first compressor head **(102)** to the second compressor head **(104)** and wherein when the second compressor head **(104)** is in the exhaust stroke the portion of the second gas flow is diverted from the second compressor head **(104)** to the first compressor head **(102)**.
12. The compressor apparatus **(100)** of claim 1, further comprising:

at least one motor **(116)** in operative engagement with the first compressor head **(102)** and the second compressor head **(104)** for driving the diaphragm **(126A, 126B)** in the reciprocating motion.

13. A method for using a compressor apparatus **(100)** comprising:
- providing a compressor apparatus **(100)** comprising:
 - a first compressor head **(102)** for generating a first gas flow;
 - a second compressor head **(104)** in fluid flow communication with the first compressor head **(102)** for generating a second gas flow;
 - an output connector **(106)** in fluid flow communication with the first compressor head **(102)** and the second compressor head **(104)** for permitting a continuous alternating output of gas flow by the first compressor head **(102)** and the second compressor head **(104)**; and
 - a shuttling by-pass component **(108)** in fluid flow communication with the first compressor head **(102)** and the second compressor head **(104)** for permitting alternating gas flow between the first compressor head **(102)** and the second compressor head **(104)** through the shuttling by-pass component **(108)** such that a portion of the first gas flow is diverted from the first compressor head **(102)** to the second compressor head **(104)** and a portion of the second gas flow is diverted from the second compressor head **(104)** to the first compressor head **(102)** in alternating sequence;
 - diverting a portion of the first gas flow from the first compressor head **(102)** to the second compressor head **(104)** through the shuttling by-pass component **(108)**; and
 - diverting a portion of the second gas flow from the second compressor head **(104)** to the first compressor head **(102)** through the shuttling by-pass component **(108)** in alternating sequence with

diverting the portion of the first gas flow from the first compressor head **(102)** to the second compressor head **(104)**.

14. The method of claim 13, wherein diverting the portion of the first gas flow from the first compressor head **(102)** to the second compressor head **(104)** alternates with diverting the portion of the second gas flow from the second compressor head **(104)** to the first compressor head **(102)**.
15. The method of claim 13, wherein diverting the portion of the first gas flow from the first compressor head **(102)** to the second compressor head **(104)** alternates with diverting the portion of the second gas flow from the second compressor head **(104)** to the first compressor head **(102)** allows for the operation of the compressor apparatus **(100)** at less than full potential capacity of both the first compressor head **(102)** and the second compressor head **(104)**, respectively.
16. A method of manufacturing a compressor apparatus **(100)** comprising:
 - engaging a first compressor head **(102)** to a second compressor head **(104)** with an output connector **(106)** to permit an output of a first gas flow from the first compressor head **(102)** and an output of a second gas flow from the second compressor head **(104)** in an alternating sequence;
 - engaging a shuttling by-pass component **(108)** between the first compressor head **(102)** and the second compressor head **(104)** for establishing fluid flow communication between the first compressor head **(102)** and the second compressor head **(104)** to permit a portion of the outputted first gas flow to flow from the first compressor head **(102)** to the second compressor head **(104)** and a portion of the outputted second gas flow to flow from the second compressor head **(104)** to the first compressor head **(102)** in alternating sequence; and
 - operatively engaging a motor **(116)** with the first compressor head **(102)** and the second compressor head **(104)** for driving the first compressor head **(102)** and the second compressor head **(104)** in alternating sequence.

17. The method of claim 16, wherein the output connector **(106)** is a first output connector **(106A)** for outputting the first gas flow from the first compressor head **(102)** and a second output connector **(106B)** for outputting the second gas flow from the second compressor head **(104)**.
18. The method of claim 16, wherein the first compressor head **(102)** further comprises a first diaphragm **(126A)** for generating the first gas flow during an intake stroke of the first compressor head **(102)** and the second compressor head **(104)** further comprises a second diaphragm **(126B)** for generating the second gas flow during an intake stroke of the second compressor head **(104)**.
19. The method of claim 18, wherein the first diaphragm **(126A)** causes a portion of the first gas flow to be diverted through the shuttling by-pass component **(108)** to the second compressor head **(104)** during an exhaust stroke of the first compressor head **(102)** and wherein the second diaphragm **(126B)** causes a portion of the second gas flow to be diverted through the shuttling by-pass **(108)** component to the first compressor head **(102)** during an exhaust stroke of the second compressor head **(104)**.
20. The method of claim 16, wherein the shuttling by-pass component **(108)** includes a by-pass orifice **(149)** for permitting the flow of either the diverted first gas flow or the diverted second gas flow through the shuttling by-pass component **(108)** when the by-pass orifice **(149)** is in the open position and preventing the flow of either the diverted first gas flow or the diverted second gas flow when the by-pass orifice **(149)** is in the closed position.

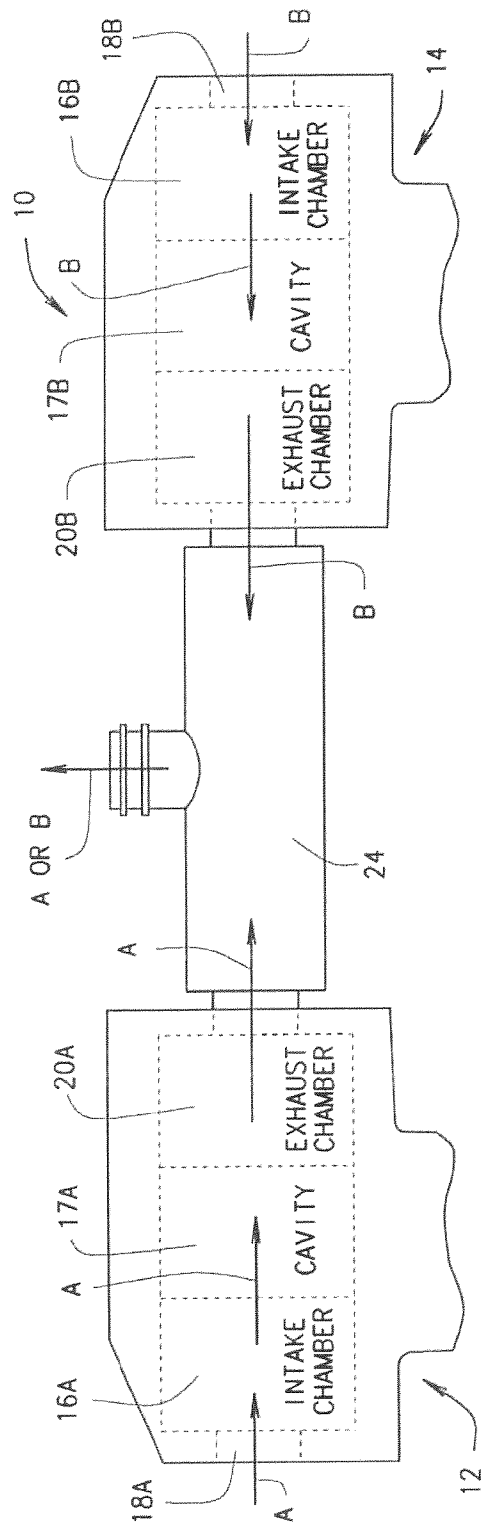
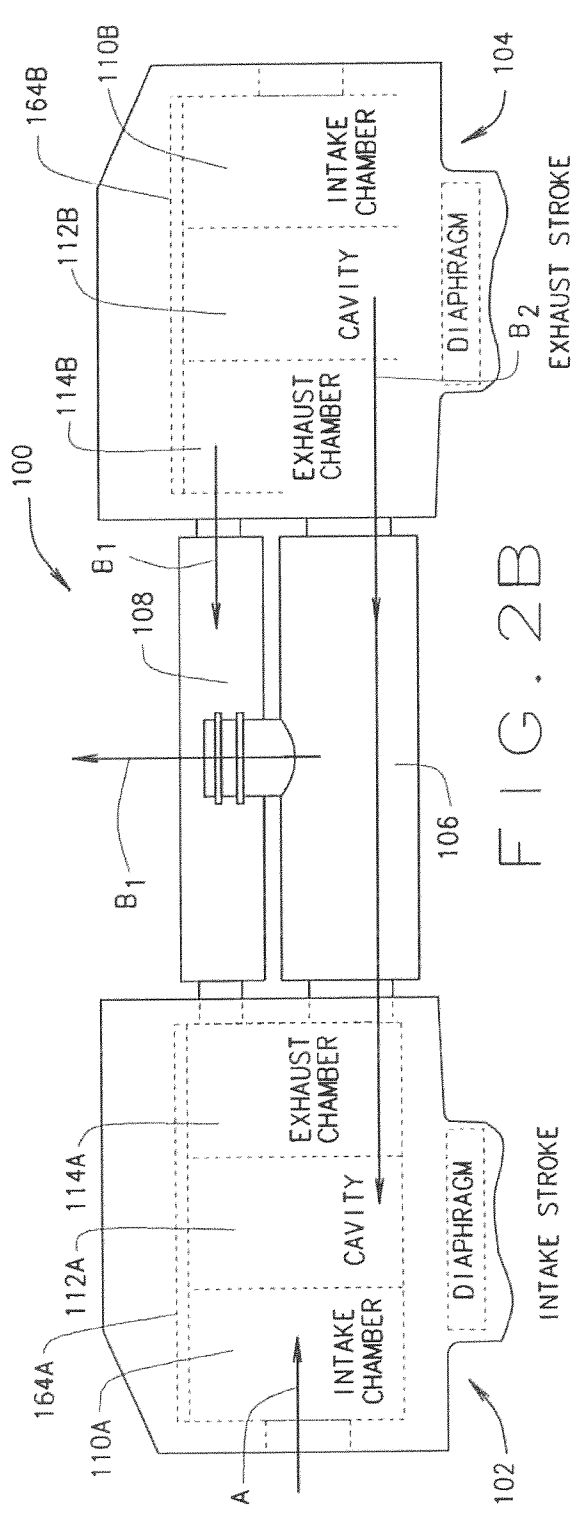
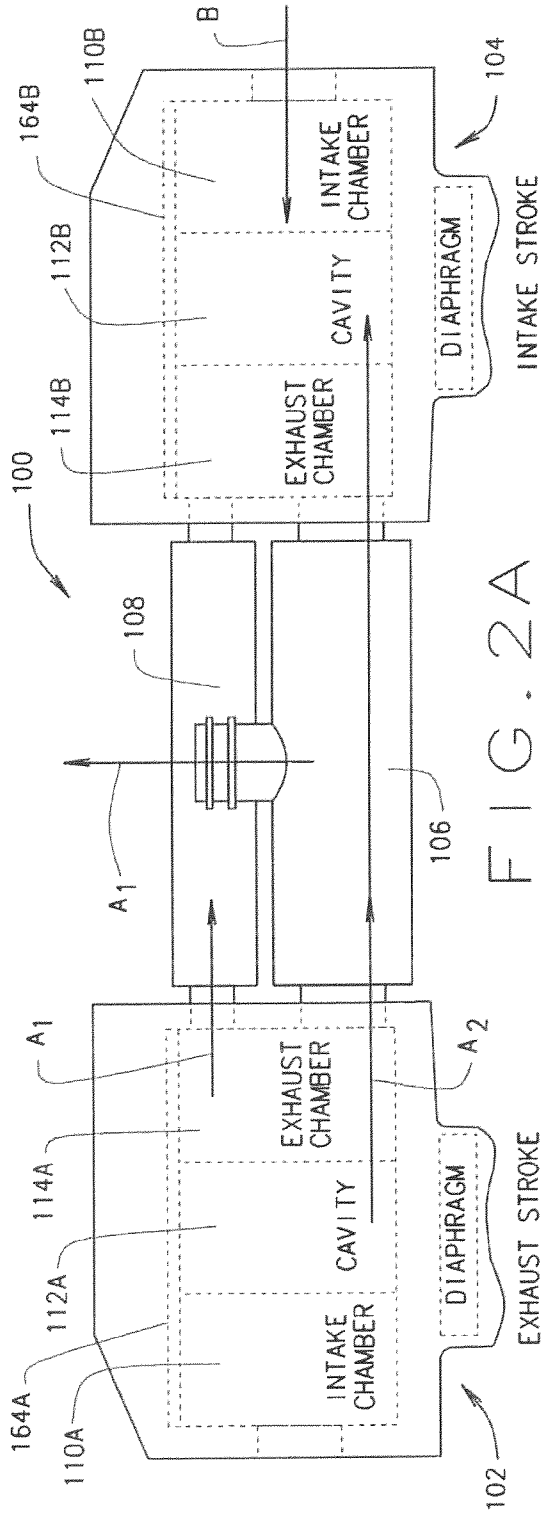
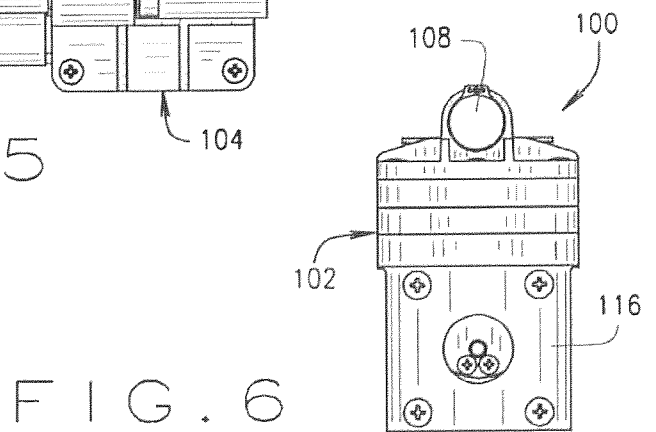
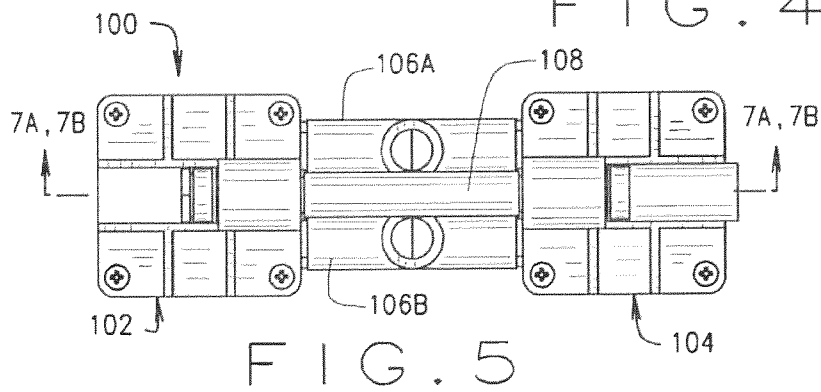
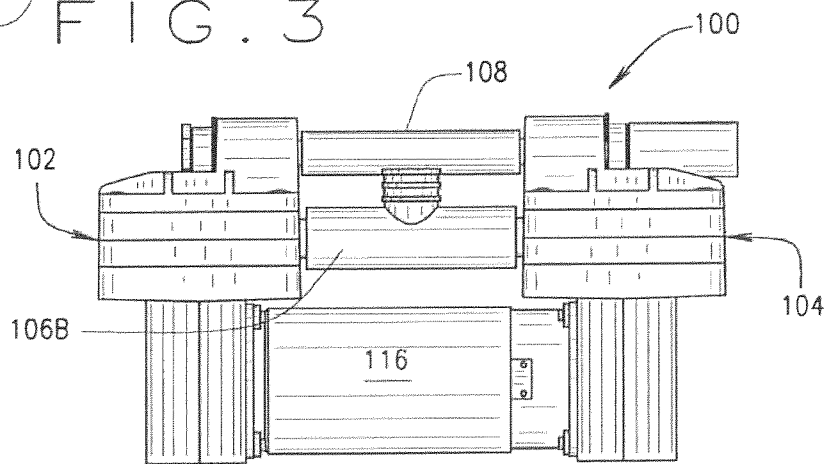
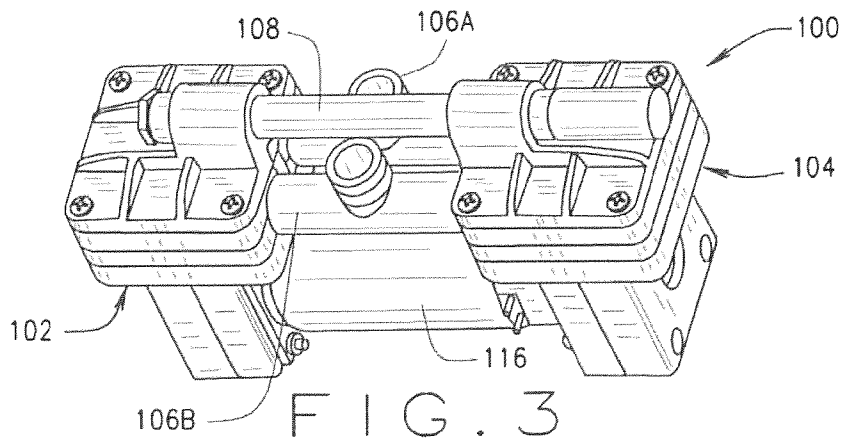

FIG. 1
PRIOR ART





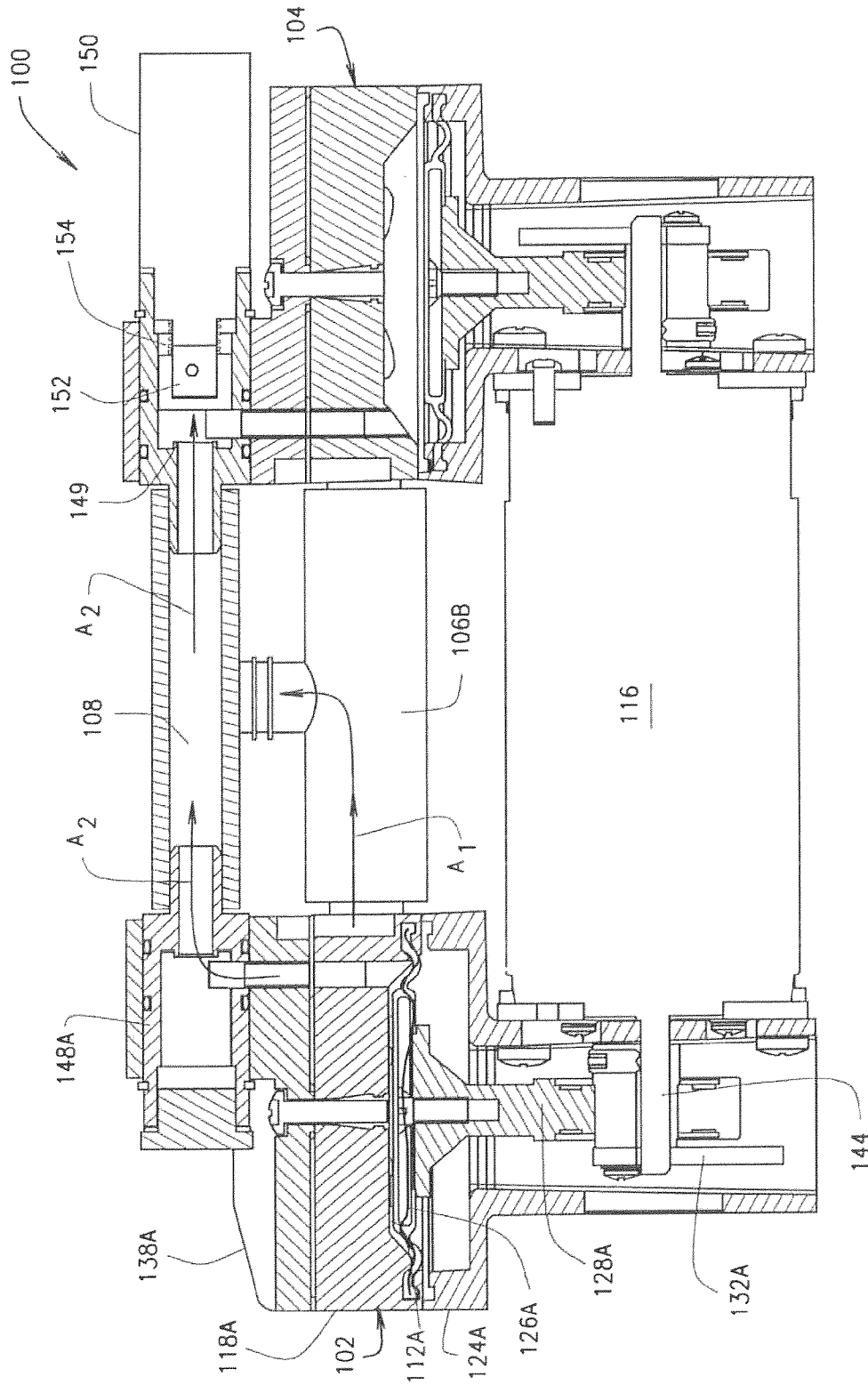

FIG. 7A

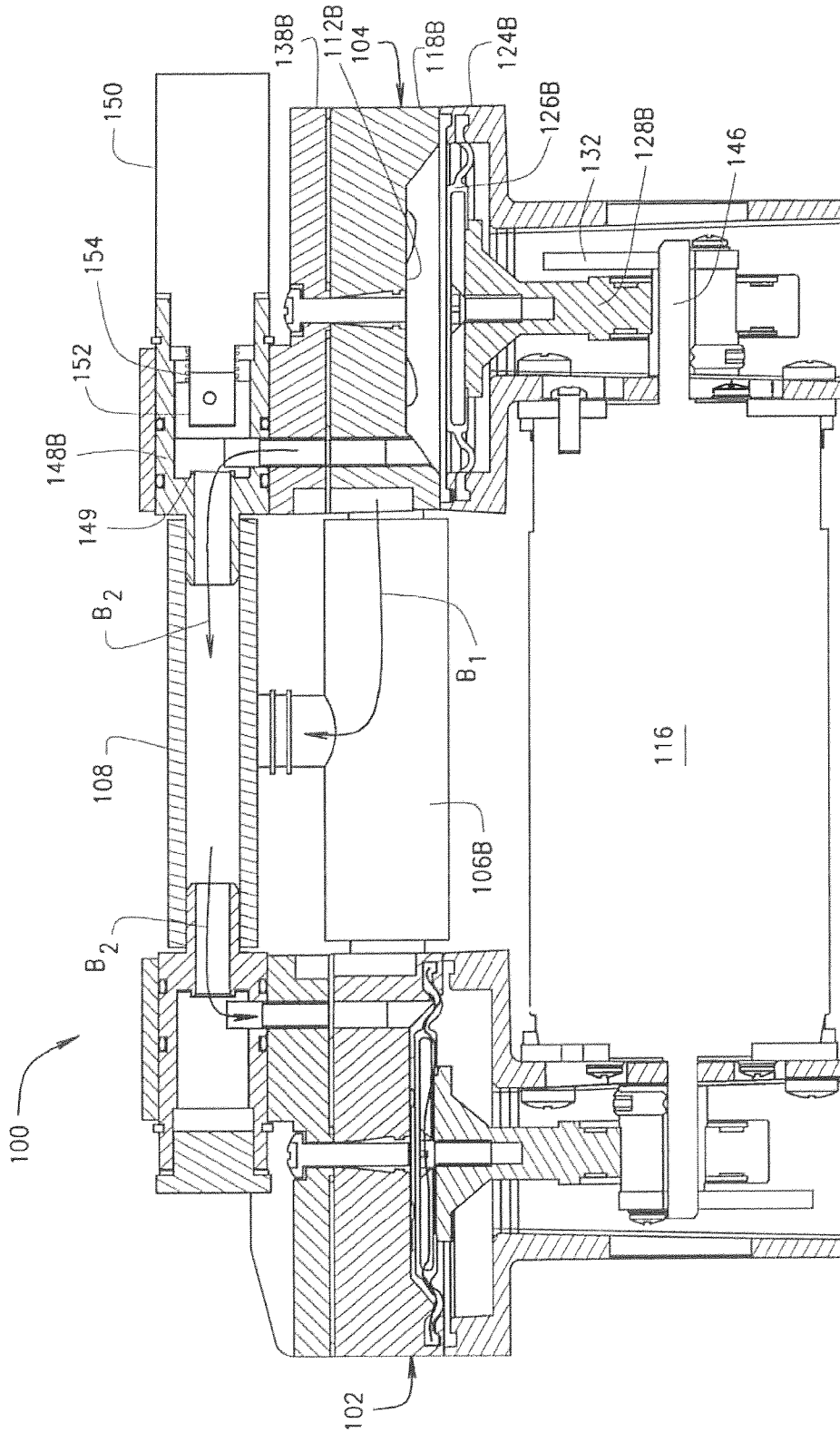

FIG. 7B

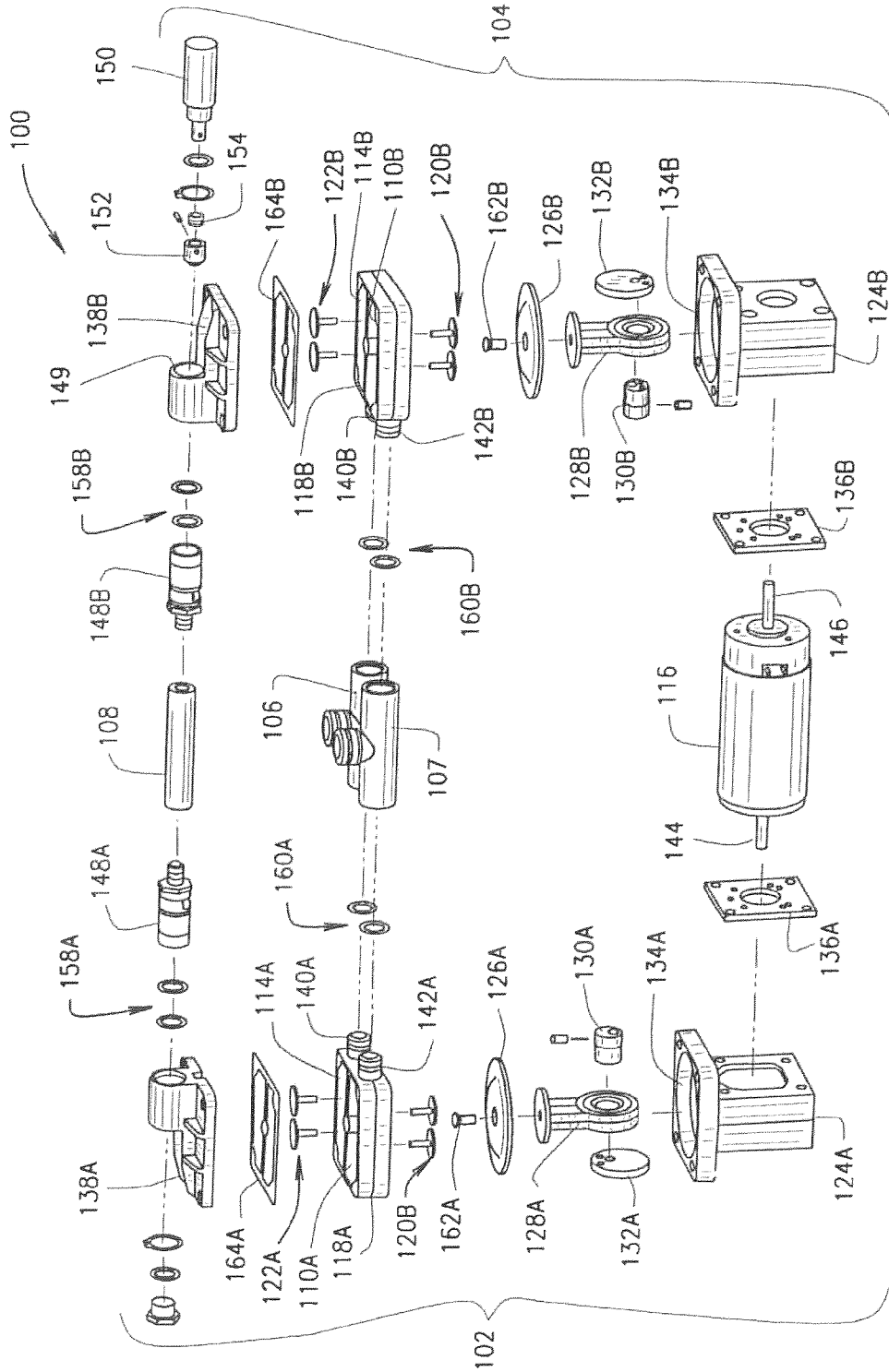

FIG. 8

7/9

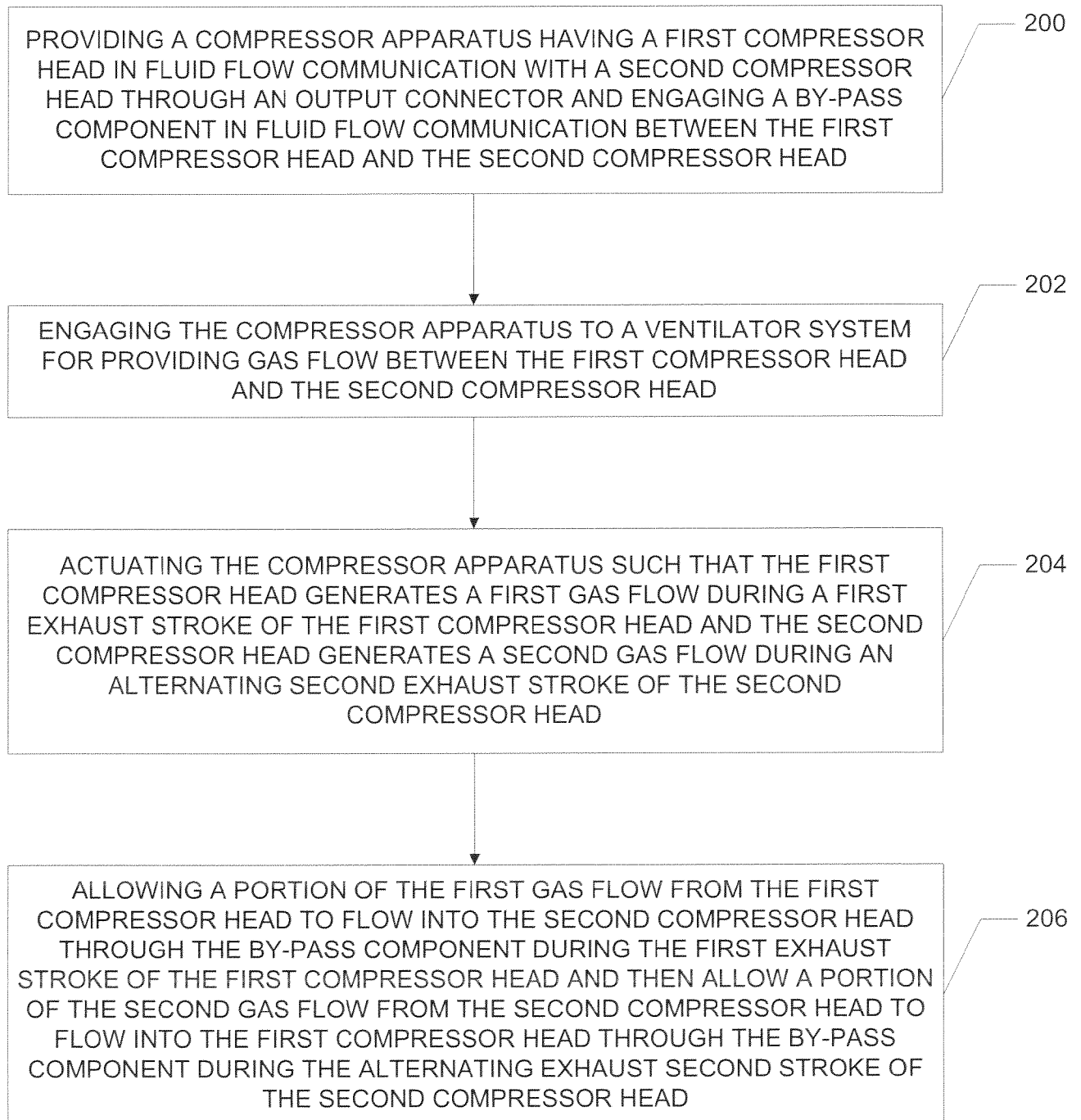

FIG. 9

8/9

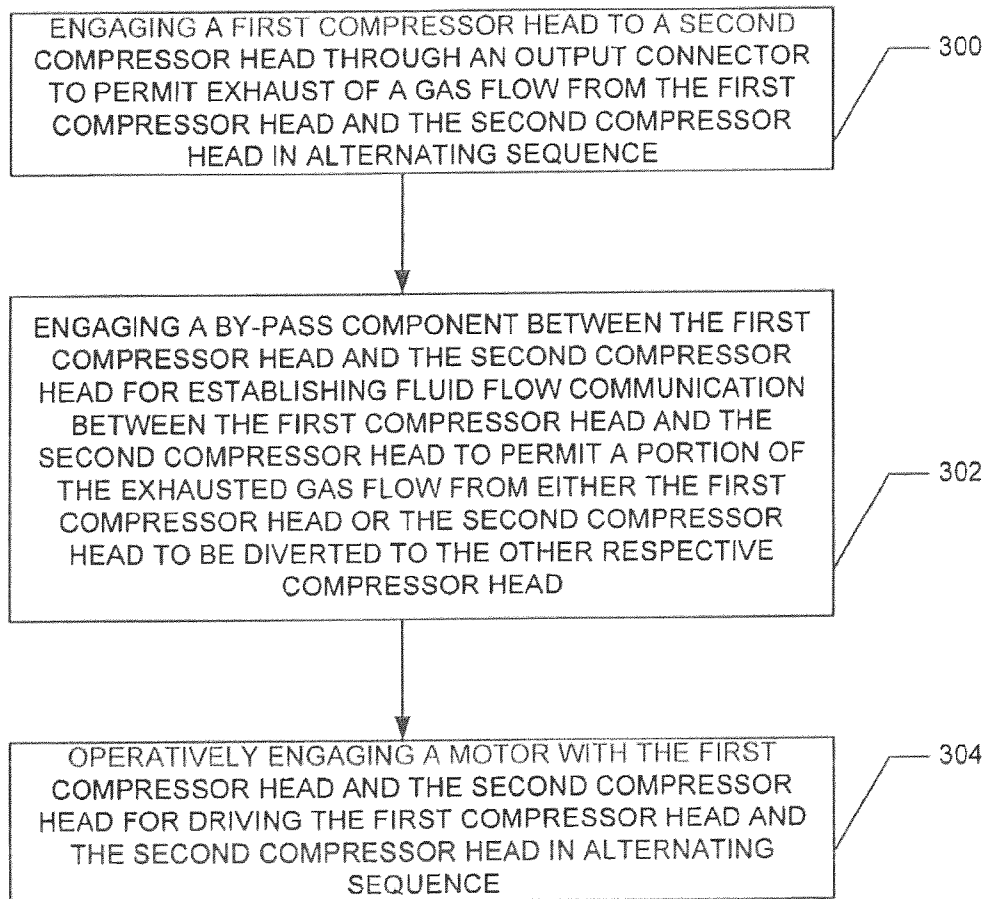

FIG. 10

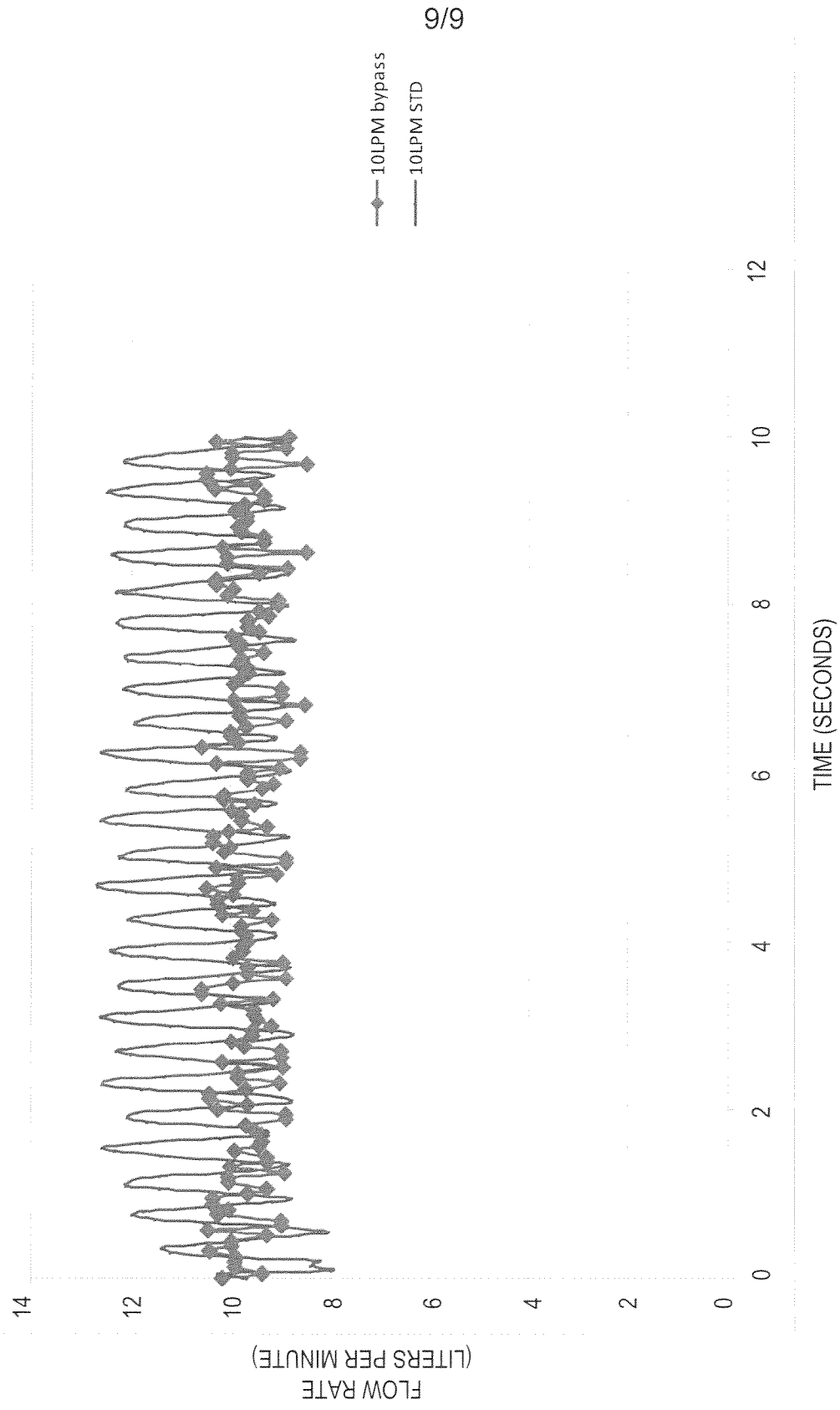

FIG. 11

INTERNATIONAL SEARCH REPORT

International application No.

PCT/US2012/049715

<p>A. CLASSIFICATION OF SUBJECT MATTER IPC(8) - A61M 16/00 (2012.01) USPC - 128/204.18 According to International Patent Classification (IPC) or to both national classification and IPC</p>																	
<p>B. FIELDS SEARCHED</p> <p>Minimum documentation searched (classification system followed by classification symbols) IPC(8) - A61M 16/00, 16/20; A62B 7/00 (2012.01) USPC - 128/204.18, 204.26, 205.18, 205.24; 137/111; 417/288, 307; 600/529</p> <p>Documentation searched other than minimum documentation to the extent that such documents are included in the fields searched</p> <p>Electronic data base consulted during the international search (name of data base and, where practicable, search terms used) PatBase</p>																	
<p>C. DOCUMENTS CONSIDERED TO BE RELEVANT</p> <table border="1"> <thead> <tr> <th>Category*</th> <th>Citation of document, with indication, where appropriate, of the relevant passages</th> <th>Relevant to claim No.</th> </tr> </thead> <tbody> <tr> <td>Y</td> <td>US 7,686,870 B1 (DEANE et al) 30 March 2010 (30.03.2010) entire document</td> <td>1-20</td> </tr> <tr> <td>Y</td> <td>US 2004/0221845 A1 (PRANGER et al) 11 November 2004 (11.11.2004) entire document</td> <td>1-20</td> </tr> <tr> <td>Y</td> <td>US 3,101,708 A (PERRY et al) 27 August 1963 (27.08.1963) entire document</td> <td>6</td> </tr> <tr> <td>Y</td> <td>US 2009/0065007 A1 (WILKINSON et al) 12 March 2009 (12.03.2009) entire document</td> <td>7, 12, 18, 19</td> </tr> </tbody> </table>			Category*	Citation of document, with indication, where appropriate, of the relevant passages	Relevant to claim No.	Y	US 7,686,870 B1 (DEANE et al) 30 March 2010 (30.03.2010) entire document	1-20	Y	US 2004/0221845 A1 (PRANGER et al) 11 November 2004 (11.11.2004) entire document	1-20	Y	US 3,101,708 A (PERRY et al) 27 August 1963 (27.08.1963) entire document	6	Y	US 2009/0065007 A1 (WILKINSON et al) 12 March 2009 (12.03.2009) entire document	7, 12, 18, 19
Category*	Citation of document, with indication, where appropriate, of the relevant passages	Relevant to claim No.															
Y	US 7,686,870 B1 (DEANE et al) 30 March 2010 (30.03.2010) entire document	1-20															
Y	US 2004/0221845 A1 (PRANGER et al) 11 November 2004 (11.11.2004) entire document	1-20															
Y	US 3,101,708 A (PERRY et al) 27 August 1963 (27.08.1963) entire document	6															
Y	US 2009/0065007 A1 (WILKINSON et al) 12 March 2009 (12.03.2009) entire document	7, 12, 18, 19															
<p><input type="checkbox"/> Further documents are listed in the continuation of Box C. <input type="checkbox"/></p>																	
<p>* Special categories of cited documents:</p> <table border="0"> <tr> <td>“A” document defining the general state of the art which is not considered to be of particular relevance</td> <td>“T” later document published after the international filing date or priority date and not in conflict with the application but cited to understand the principle or theory underlying the invention</td> </tr> <tr> <td>“E” earlier application or patent but published on or after the international filing date</td> <td>“X” document of particular relevance; the claimed invention cannot be considered novel or cannot be considered to involve an inventive step when the document is taken alone</td> </tr> <tr> <td>“L” document which may throw doubts on priority claim(s) or which is cited to establish the publication date of another citation or other special reason (as specified)</td> <td>“Y” document of particular relevance; the claimed invention cannot be considered to involve an inventive step when the document is combined with one or more other such documents, such combination being obvious to a person skilled in the art</td> </tr> <tr> <td>“O” document referring to an oral disclosure, use, exhibition or other means</td> <td>“&” document member of the same patent family</td> </tr> <tr> <td>“P” document published prior to the international filing date but later than the priority date claimed</td> <td></td> </tr> </table>			“A” document defining the general state of the art which is not considered to be of particular relevance	“T” later document published after the international filing date or priority date and not in conflict with the application but cited to understand the principle or theory underlying the invention	“E” earlier application or patent but published on or after the international filing date	“X” document of particular relevance; the claimed invention cannot be considered novel or cannot be considered to involve an inventive step when the document is taken alone	“L” document which may throw doubts on priority claim(s) or which is cited to establish the publication date of another citation or other special reason (as specified)	“Y” document of particular relevance; the claimed invention cannot be considered to involve an inventive step when the document is combined with one or more other such documents, such combination being obvious to a person skilled in the art	“O” document referring to an oral disclosure, use, exhibition or other means	“&” document member of the same patent family	“P” document published prior to the international filing date but later than the priority date claimed						
“A” document defining the general state of the art which is not considered to be of particular relevance	“T” later document published after the international filing date or priority date and not in conflict with the application but cited to understand the principle or theory underlying the invention																
“E” earlier application or patent but published on or after the international filing date	“X” document of particular relevance; the claimed invention cannot be considered novel or cannot be considered to involve an inventive step when the document is taken alone																
“L” document which may throw doubts on priority claim(s) or which is cited to establish the publication date of another citation or other special reason (as specified)	“Y” document of particular relevance; the claimed invention cannot be considered to involve an inventive step when the document is combined with one or more other such documents, such combination being obvious to a person skilled in the art																
“O” document referring to an oral disclosure, use, exhibition or other means	“&” document member of the same patent family																
“P” document published prior to the international filing date but later than the priority date claimed																	
<p>Date of the actual completion of the international search</p> <p>10 October 2012</p>	<p>Date of mailing of the international search report</p> <p align="center">26 OCT 2012</p>																
<p>Name and mailing address of the ISA/US</p> <p>Mail Stop PCT, Attn: ISA/US, Commissioner for Patents P.O. Box 1450, Alexandria, Virginia 22313-1450 Facsimile No. 571-273-3201</p>	<p>Authorized officer:</p> <p align="center">Blaine R. Copenheaver</p> <p>PCT Helpdesk: 571-272-4300 PCT OSP: 571-272-7774</p>																