

No. 801,103.

PATENTED OCT. 3, 1905.

A. RECTOR.
COMBINATION MANTLE AND SHADE HOLDER.
APPLICATION FILED APR. 30, 1904. RENEWED AUG. 30, 1905.

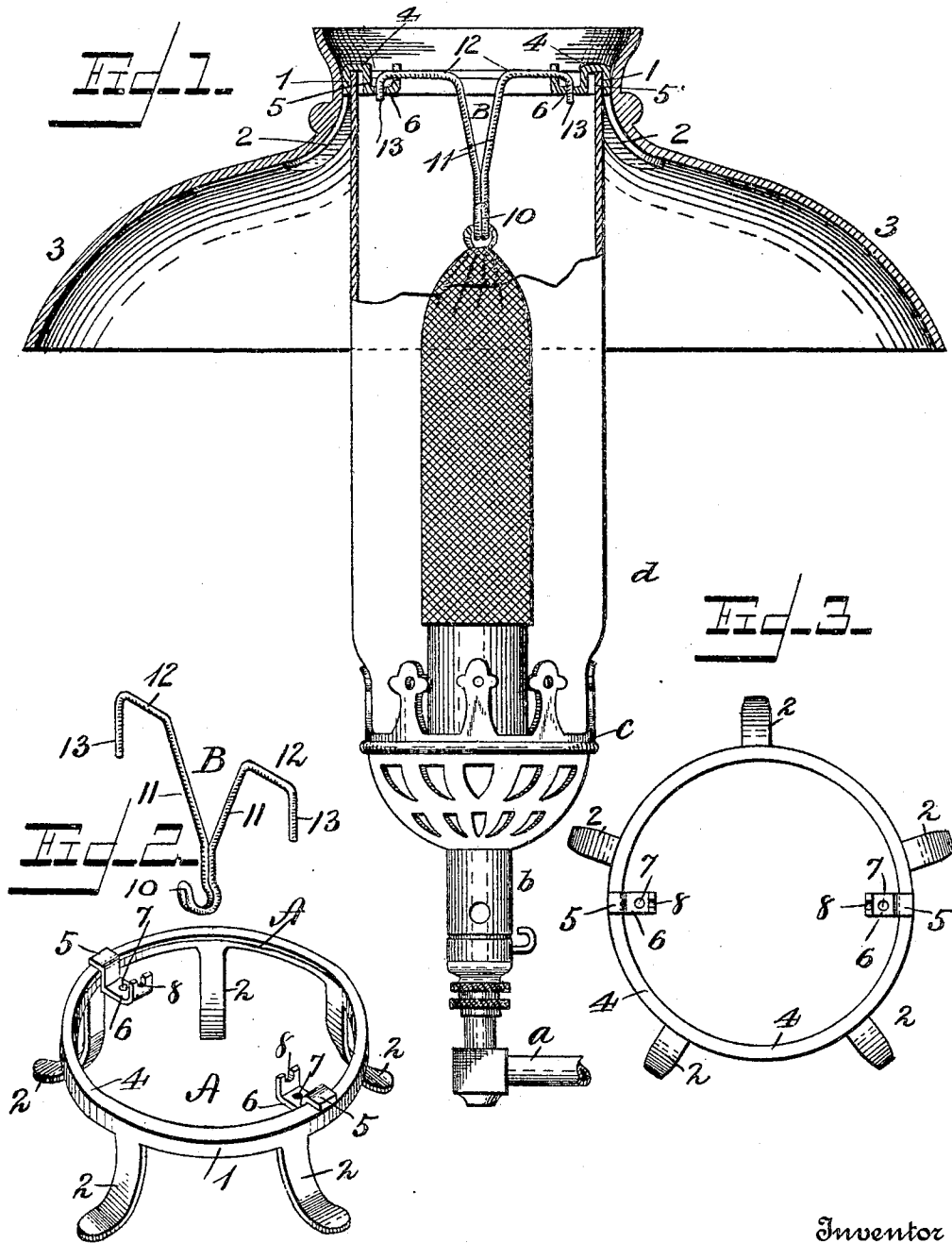

Witnesses
F. L. Orvand
Celle C. Pratt.

Inventor
Alcom Rector
By *J. M. Duffel*
Attorney

UNITED STATES PATENT OFFICE.

ALCORN RECTOR, OF NEW YORK, N. Y., ASSIGNOR TO THE RECTOR LIGHT COMPANY, OF STAMFORD, CONNECTICUT.

COMBINATION MANTLE AND SHADE HOLDER.

No. 801,103.

Specification of Letters Patent.

Patented Oct. 3, 1905.

Application filed April 30, 1904. Renewed August 30, 1905. Serial No. 276,476.

To all whom it may concern:

Be it known that I, ALCORN RECTOR, a citizen of the United States, residing at New York, in the county of New York and State of New York, have invented new and useful Improvements in Combination Mantle and Shade Holders, of which the following is a specification.

My invention is a combination mantle and shade holder; and it consists in the novel construction and arrangement of its parts, as set forth in the following specification and claims.

In the accompanying drawings, Figure 1 is an elevation of a lamp or gas burner with my invention illustrated in section thereon. Fig. 2 is a perspective view of my combined mantle and shade holder. Fig. 3 is a top plan view of the shade-holder with two brackets attached thereto.

In the accompanying drawings, *a* represents the tip end of a gas-chandelier.

b represents my improved burner.

c represents the gallery; *d*, the chimney seated in the gallery. The upper part of the chimney is shown in section, so that my invention may be shown in section seated thereon.

My invention is described as follows:

A is the cap, in which 1 represents a circular band having projecting from its lower edge arms 2, which turn outwardly at a suitable angle to support a shade 3. Extending inwardly from the upper edge of the band 1 is a circular flange 4. This flange is not necessarily much wider than the thickness of the chimney, just being wide enough to allow contraction and expansion. This cap rests on the top of the chimney. Extending inwardly and immediately opposite each other from the flange 4 is a pair of brackets 5. These brackets when they reach the inner edge of the flange 4 turn immediately down parallel with the band, then inwardly at right angles to said band, forming in each a base 6. This base is provided at its center with a perforation 7; then these brackets turn upwardly at right angles to the base, and are bifurcated, leaving at their ends recesses 8; a mantle-support B, consisting of a hook 10; extending up from the hook, is a shank 11, which may or may not be divided; then, splitting and extending outwardly on a horizontal line are arms 12; then downwardly at right angles to said arms forming pins 13. This mantle-support B rests in

the brackets thus: The pins 13 pass down through the perforations 7 and the arms in the recesses 8 of the brackets, and the mantle is secured in the hook 10. Thus it will be seen that the support can swing neither to the right nor left nor forward nor back, and consequently the mantle is constantly and steadily in the center of the chimney and over the burner. This is a great advantage, because if the mantle be allowed to swing in either direction it is certain to be broken, as it is very fragile. Another great advantage in having the mantle supported from the center is the fact that I thereby do away with the side wires, which are not only unsightly, but more or less obstruct the light and are certain in a short time to be bent by the heat, thereby throwing the mantle out of center, and so cause the flame to run up one side of the mantle and only give a partial light and smoke to the other side. A central wire is subject to the same conditions and will produce the same unsatisfactory results, and another advantage is as I have no side wires the mantle stands out clear and unobstructed and is a thing of beauty.

Having described my invention, what I claim as new, and desire to secure by Letters Patent, is—

1. The combination of a circular band 1; arms 2, extending downwardly and outwardly from the lower edge of said band; a circular flange 4, extending inwardly at right angles from the upper edge of said band; brackets 5, immediately opposite each other, extending downwardly, parallel with said band, then inwardly, parallel with said flange, forming in each a base 6; then upwardly, parallel with said band, having in each base a perforation 7, and in each end a recess 8; a mantle-support consisting of a hook 10, shank 11, arms 12, extending outwardly on a horizontal line, and pins 13, extending downwardly from said arms, said arms adapted to rest in the recesses 8, and the pins 13, in the perforations 7, of the said brackets, substantially as shown and described and for the purposes set forth.

2. The combination of a circular band; arms extending outwardly and downwardly from said band; a circular flange, extending inwardly from the upper edge of said band; brackets immediately opposite each other, extending downwardly parallel with said band,

then inwardly, forming in each a base 6, then
upwardly, said brackets having in each base
a perforation 7, and in each end a recess 8; a
mantle-support provided at the lower end of
5 its shank with means to suspend the mantle,
and arms, extending horizontally from the
shank of said support, then downwardly, form-
ing pins, said arms adapted to rest in the re-
cesses and the pins in the perforations of said

brackets, substantially as shown and described 10
and for the purposes set forth.

In testimony whereof I have signed my name
to this specification in the presence of two sub-
scribing witnesses.

ALCORN RECTOR.

Witnesses:

A. E. OSBORNE,

M. J. CRAWFORD.