



INTERNATIONAL APPLICATION PUBLISHED UNDER THE PATENT COOPERATION TREATY (PCT)

(51) International Patent Classification ⁶ : A61B 17/39	A1	(11) International Publication Number: WO 95/19739 (43) International Publication Date: 27 July 1995 (27.07.95)
(21) International Application Number: PCT/IB94/00353 (22) International Filing Date: 14 November 1994 (14.11.94) (30) Priority Data: 08/184,515 21 January 1994 (21.01.94) US (71) Applicant: VALLEYLAB, INC. [US/US]; 5920 Longbow Drive, Boulder, CO 80301 (US). (72) Inventors: CIMINO, William, W.; 578 West Sagebrush Court, Louisville, CO 80027 (US). LONTINE, Michael, D.; 9925 Hoyt Lane, Westminster, CO 80021 (US). SCHOLLMAYER, Michael, P.; 1217 Columbia Drive, Longmont, CO 80503 (US). (74) Agents: SPIEGEL, Allen, J. et al.; Pfizer Inc., 235 East 42nd Street, New York, NY 10017 (US).	(81) Designated States: AU, CA, DE (Utility model), JP, European patent (AT, BE, CH, DE, DK, ES, FR, GB, GR, IE, IT, LU, MC, NL, PT, SE). Published <i>With international search report.</i>	

(54) Title: ELECTROSURGICAL TIPS**(57) Abstract**

An electrosurgical tip (10) for the application of electromagnetic energy in either a monopolar or a bipolar circuit through the tissue and the bodily fluids of an animal or human (13) has a metallic electrically and thermally conductive electrode for connection to an electrosurgical generator proximally and for transmission of the electromagnetic electrosurgical energy (12) to the tissue and the bodily fluids of the animal or human (13) distally. A sheath (18) of heat shrinkable fluorinated polymeric substance is an electrical and thermal insulator (14) held about the electrode for preventing the flow of electromagnetic and thermal energy from the metallic electrically and thermally conductive electrode to the tissue and the bodily fluids. A smooth surface of the sheath (18) contacts the tissue and the bodily fluids and has a low surface free energy. Openings (16) through the sheath (18) extend from the electrode to the surface (15) for permitting the passage of energy. A wall (17) of the sheath (18) is of a thickness adequate to space the electrode from substantially any contact with the tissue and isolate heat due to the arcs. A ceramic substance (19) is an electrical and thermal insulator (14) about the conductive electrode for preventing the energy flow. A method of making the tip includes covering the electrode with the insulator, isolating physically the heat generated due to the passage of energy. A method of using the tip places the surface (15) in close proximity to the tissue and the bodily fluids, transmits the electromagnetic energy through the openings (16), allows cleaning tissue and bodily fluids from the surface (15). The use includes first passing energy through openings (16) in a wall (17) of electrical and thermal insulation and application of electromagnetic energy by either a monopolar or a bipolar circuit relative to the tissue and the bodily fluids of an animal or human (13).

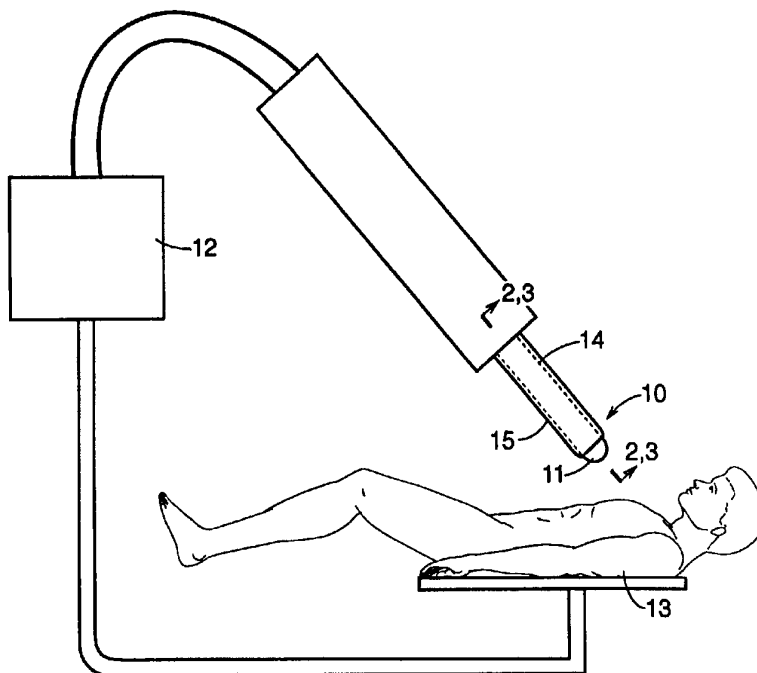

FOR THE PURPOSES OF INFORMATION ONLY

Codes used to identify States party to the PCT on the front pages of pamphlets publishing international applications under the PCT.

AT	Austria	GB	United Kingdom	MR	Mauritania
AU	Australia	GE	Georgia	MW	Malawi
BB	Barbados	GN	Guinea	NE	Niger
BE	Belgium	GR	Greece	NL	Netherlands
BF	Burkina Faso	HU	Hungary	NO	Norway
BG	Bulgaria	IE	Ireland	NZ	New Zealand
BJ	Benin	IT	Italy	PL	Poland
BR	Brazil	JP	Japan	PT	Portugal
BY	Belarus	KE	Kenya	RO	Romania
CA	Canada	KG	Kyrgystan	RU	Russian Federation
CF	Central African Republic	KP	Democratic People's Republic of Korea	SD	Sudan
CG	Congo	KR	Republic of Korea	SE	Sweden
CH	Switzerland	KZ	Kazakhstan	SI	Slovenia
CI	Côte d'Ivoire	LI	Liechtenstein	SK	Slovakia
CM	Cameroon	LK	Sri Lanka	SN	Senegal
CN	China	LU	Luxembourg	TD	Chad
CS	Czechoslovakia	LV	Latvia	TG	Togo
CZ	Czech Republic	MC	Monaco	TJ	Tajikistan
DE	Germany	MD	Republic of Moldova	TT	Trinidad and Tobago
DK	Denmark	MG	Madagascar	UA	Ukraine
ES	Spain	ML	Mali	US	United States of America
FI	Finland	MN	Mongolia	UZ	Uzbekistan
FR	France			VN	Viet Nam
GA	Gabon				

5

ELECTROSURGICAL TIPS

10

1. Field of the Invention This relates to electrosurgical tips for the application of electromagnetic energy to tissue of animal and human and more particularly to the cleanability of such tips.

15

2. Background of the Disclosure Tips for electrosurgical use are subject to high temperature at least whereat the electrosurgical arc emanates during, e. g. fulguration. The heat thus provided causes the proteins in the bodily fluids to coagulate and adhere to the tips.

20

Coatings have been used to increase the ease of cleanability of the electrosurgical tips. U. S. Patent 4,785,807 has a primer and top coating of Teflon polymer over an etched or abraded stainless steel tip. The coating is thin and during application of electromagnetic energy it is said that there is capacitive coupling to allow passage of power to the tissue being treated. Thus, the Teflon polymer surface should remain largely intact and so the cleanability of the tip is good.

25

U.S. Patent 4,492,231 discusses temperature, tip conductivity and sticking of desiccated blood in a bipolar forceps.

30

U.S. Patents 4,232,676 and 4,314,559 assigned to Corning Glass Works, disclose tips that with areas for electrosurgery and other areas which do not conduct high frequency power. The '676 patent has bipolar electrodes on the same tip so that power passing therebetween will cauterize bleeders. The '559 patent is an electrically conductive tip with a rough surface finish filled with Teflon polymer to provide non-stick properties. Thus, portions of the tip are not covered and form an electrical connection between surgical tip and the tissue. The Teflon polymer only fills interstices, inclusions and the like at the surface, thus providing non-stick areas on the cutting or coagulating instrument. The '559 patent has a surface which provides areas of Teflon polymer and raw metal and so recognizes the conductive nature of the tip and permits energy flow without the need to overcome the electrical insulation of the coating. Specifically, interstices along the surface of the metal tip

35

are filled with primer and a top coat of Teflon polymer. The surface is thus partly conductive metal and partly cleanable Teflon polymer.

Australian patent 637755 has a conductive shaft with insulation providing both electrical and thermal insulation and abrasion-resistance along the shaft between its ends, and is e.g., provided by a shrink fitted plastic tube. The purpose of this is strictly an electrical insulator with no appreciation of blade anti-coagulation.

No electrosurgical tips exist wherein a relatively thick sheath of fluorinated polymer having areas open to expose metallic conductor therewithin and provide an effective thermal and electrical barrier are known in the prior patents. It has been found that the cleanability of the electrosurgical tips is a function of surface temperature and surface free energy. The ability to provide electrosurgical energy while minimizing heat transfer to the tissue and significantly reducing adherence to the tip is presently not appreciated in the prior patents.

15

SUMMARY OF THE INVENTION

An electrosurgical tip for the application of electromagnetic energy in either a monopolar or a bipolar circuit through the tissue and the bodily fluids of an animal or human preferably has an electrically conductive electrode for connection to a source of electromagnetic electrosurgical energy and for transmission of the energy. An electrical and thermal insulator is preferably held about the conductive electrode for preventing the flow of electromagnetic and thermal energy from the electrically conductive electrode to the tissue and the bodily fluids. A surface of the electrical and thermal insulator for contact with the tissue and the bodily fluids most preferably has a low surface free energy. The surface is a fluorinated polymer.

Openings through the electrical and thermal insulator may be provided to extend from the electrically conductive electrode to the surface for the passage of energy from the electrode to the tissue and the bodily fluids. A wall of the electrical and thermal insulator between the surface of the electrical and thermal insulator and the electrically conductive electrode most preferably has a thickness ample to space the electrode from substantially any contact with the tissue and to physically isolate heat generated in the conductive electrode due to passage energy through the openings.

The electrical and thermal insulator is in a preferred embodiment a heat shrinkable polymeric sheath. The electrical and thermal insulator may alternatively be a ceramic substance with the surface thereof sheathed or treated to reduce its surface free energy. The wall of the insulator may be a porous substance having an open cellular configuration allowing passage of electromagnetic energy from the electrode to the tissue and the bodily fluids and preventing the flow of thermal energy so there is a thermal gradient between the electrically conductive electrode and the surface. The electrically conductive electrode is at least in part metallic having electrical and thermal conductivity and may perhaps be selected from the group consisting of copper, gold, silver, aluminum, ferrous alloys and alloys thereof.

The surface is in an alternative embodiment a material different from that of the sheath. The surface may have a lower surface free energy than the wall. The surface might have a coating having a low surface free energy. The coating might be lubricous. The ceramic substance may act as an electrical and thermal insulator about the conductive electrode for preventing the flow of electromagnetic and thermal energy from the conductive electrode to the tissue and the bodily fluids. The ceramic substance is preferably of a thickness ample to space the conductive electrode from substantially any contact with the tissue and to physically isolate heat generated in the conductive electrode due to flow of electromagnetic energy through the electrically conductive electrode.

A method of making an electrosurgical tip for the application of electromagnetic energy in either a monopolar or a bipolar circuit through the tissue and the bodily fluids of an animal or human has steps. Connecting an electrically conductive electrode to a source of electromagnetic electrosurgical energy may be a step. Covering the electrically conductive electrode with an electrical and thermal insulator may be a step. Providing openings in the electrical and thermal insulator, the openings extending therethrough from the electrically conductive electrode for permitting passage of electromagnetic electrosurgical energy from the electrically conductive electrode to the tissue and the bodily fluids may be a step. Providing the surface with a low surface free energy may be a step. Extending the openings through the surface may be a step. Providing a wall in the electrical and thermal insulator between the surface and the electrically conductive electrode may be a step. Making the wall of a thickness ample to space the conductive electrode from

substantially any contact with the tissue of the animal or human may be a step. Isolating physically the heat generated due to the passage of energy from the electrically conductive electrode through the openings to the tissue and the bodily fluids of the animal or human may be a step.

5 The method of making may include the step of covering performed by heat shrinking a polymeric tube placed over the electrically conductive electrode. The method of making might have the step of providing the openings performed before or after heat shrinking the tube. A method of using an electrosurgical tip that is electrically and thermally insulated but has openings for passage of and the
10 application of electromagnetic energy in either a monopolar or a bipolar circuit through the tissue and the bodily fluids of an animal or human has steps. Placing in close proximity to the tissue and the bodily fluids of the animal or human a surface of the electrical and thermal insulator may be a step. Transmitting the electromagnetic energy through the openings to the tissue and the bodily fluids of
15 the animal or human may be a step. Cleaning tissue and bodily fluids from the surface may be a step. Transmitting the electromagnetic energy includes first passing it through openings in a wall of electrical and thermal insulation may be a step. Application of electromagnetic energy either by monopolar or bipolar circuitry relative to the tissue and the bodily fluids of an animal or human is a step.

20

BRIEF DESCRIPTION OF THE DRAWINGS

Figure 1 is an electrosurgical tip for the application of electromagnetic energy in either a monopolar or a bipolar circuit shown schematically and in perspective.

25 Figure 2 is a side view in cross section as taken along lines 2-2 of Figure 1 of the preferred embodiment of an electrosurgical tip.

Figure 3 is a side view in cross section as taken along lines 3-3 of Figure 1 of the alternate embodiment of an electrosurgical tip.

30 Figure 4 is a side view in cross section of an electrosurgical tip showing schematically the coating or layer having a low surface energy and the porous material permitting the passage of electrically conductive energy.

DETAILED DESCRIPTION OF THE INVENTION

In Figure 1 is an electrosurgical tip 10 for the application of electromagnetic energy in either a monopolar or a bipolar circuit and is shown schematically in perspective and in the alternative. In Figure 2, a side view in cross section as taken
5 along lines 2-2 of Figure 1 of the preferred embodiment, the electrosurgical tip is disclosed. Figure 4 is another side view in cross section of the electrosurgical tip which shows schematically a coating or layer having a low surface energy and a porous material permitting the passage of electrically conductive energy. An electrically conductive electrode 11 connects to a source of electromagnetic
10 electrosurgical energy 12 for transmission of the electromagnetic electrosurgical energy to the tissue and the bodily fluids of the animal or human 13. An electrical and thermal insulator 14 is held about the electrically conductive electrode 11 for preventing the flow of electromagnetic and thermal energy from the electrically conductive electrode 11 to the tissue and the bodily fluids. A surface 15 of the
15 electrical and thermal insulator 14 contacts the tissue and the bodily fluids of the animal or human 13. The surface having a low surface free energy. Openings 16 through the electrical and thermal insulator 14 extend from the electrically conductive electrode 11 to the surface 15 for the passage of electromagnetic electrosurgical energy from the electrically conductive electrode 11 to the tissue and
20 the bodily fluids.

A wall 17 of the electrical and thermal insulator 14 is between the surface 15 of the electrical and thermal insulator 14 and the electrically conductive electrode 11. The wall 17 is of a thickness ample to space the conductive electrode 11 from substantially any contact with the tissue of the animal or human 13 and to physically
25 isolate heat generated in the conductive electrode due to the passage of energy from the electrically conductive electrode 11 through the openings 16 to the tissue and the bodily fluids of the animal or human 13. Thickness of fluorocarbon polymer in the range of 3 to 10 thousandths of an inch are preferred.

In Figure 3, a side view in cross section as taken along lines 3-3 of Figure 1,
30 the alternate embodiment of the electrosurgical tip 10 is revealed. Specifically, the electrical and thermal insulator 14 may be a sheath 18 of a polymeric substance (Figure 2) or a ceramic substance 19 (Figure 3). The surface 15 of the sheath 18 may be treated to reduce its surface free energy. The wall 17 of the sheath 18 may

be in one embodiment a porous substance having an open cellular configuration, as shown in Figure 4, allowing passage of electromagnetic energy from the electrically conductive electrode 11 to the tissue and the bodily fluids while preventing the flow of thermal energy and/or electromagnetic energy so there is a thermal gradient
5 between the electrically conductive electrode 11 and the surface 15.

The electrically conductive electrode 11 is at least in part metallic and preferably medical grade stainless steel, having electrical and thermal conductivity or could be selected from the group consisting of copper, gold, silver, aluminum, ferrous alloys and alloys thereof. The surface 15 is preferably a fluorinated polymer,
10 e.g. Teflon by DuPont. The surface 15 may be a material different from that of the sheath 18 to minimize its surface free energy. The surface 15 may have an extra coating (not shown) having a low surface free energy or to reduce the surface free energy of the surface 15. The coating may be lubricous, i.e. lanolin, silicone, etc. The surface 15 of the sheath 18 if ceramic, porous or such that it has high surface
15 free energy is preferably coated with a material of low surface free energy, e.g. a flourocarbon or silicone and in that instance the coating thickness can be thin in the range of 1/2 to 3 thousandths of an inch since the thermal barrier is the sheath 18.

The sheath 18 is most preferably of a heat shrinkable polymeric substance, as an electrical and thermal insulator, slid over the electrically conductive electrode
20 and held thereabout for preventing the flow of electromagnetic and thermal energy from the electrically conductive electrode to the tissue and the bodily fluids. The sheath 18 of a heat shrinkable polymer may be applied over the ceramic substance 19 as in Figure 3 for surrounding and for contact with the tissue and the bodily fluids of the animal or human 13. The openings 16 in that alternate embodiment can be
25 through the sheath 18 and the ceramic substance 19.

A method of making the electrosurgical tip 10 for the application of electromagnetic energy in either a monopolar or a bipolar circuit through the tissue and the bodily fluids of the animal or human 13 has steps. Connecting the electrically conductive electrode 11 to the source of electromagnetic electrosurgical
30 energy 12 is a step in making the electrosurgical tip 10. Covering the electrically conductive electrode 11 with the electrical and thermal insulator 14 is another step in the making of the electrosurgical tip 10. Providing openings 16 in the electrical and thermal insulator 14 so that the openings 16 extend therethrough from the

electrically conductive electrode 11 for permitting passage of electromagnetic electrosurgical energy from the electrically conductive electrode 11 to the tissue and the bodily fluids is a further step in the making.

Then the step of providing the surface 15 with a low surface free energy is performed. Extending the openings 16 through the surface 15 allows the passage of electromagnetic energy. Providing the wall 17 in the electrical and thermal insulator between the surface 15 and the electrically conductive electrode 11 is a step. Making the wall 17 of a thickness ample to space the electrically conductive electrode 11 from substantially any contact with the tissue of the animal or human 13 is the step that prevents thermal energy transmission. Isolating physically the heat generated in the conductive electrode due to the passage of energy from the electrically conductive electrode 11 through the openings 16 to the tissue and the bodily fluids of the animal or human 13 is another step. The step of covering is preferably performed by heat shrinking a polymeric tube placed over the electrically conductive electrode 11. The step of providing the openings 16 may be performed before heat shrinking the tube. The step of providing the openings 16 may alternately be performed after heat shrinking the tube.

A method of using the electrosurgical tip 10 that is electrically and thermally insulated but has openings 16 for passage of and the application of electromagnetic energy in either a monopolar or a bipolar circuit through the tissue and the bodily fluids of the animal or human 13 has steps. Placing in close proximity to the tissue and the bodily fluids of the animal or human 13 the surface 15 of the electrical and thermal insulator 14 is a step. Transmitting the electromagnetic energy through the openings 16 to the tissue and the bodily fluids of the animal or human 13 is a further step. Cleaning tissue and bodily fluids from the surface 15 is another step. The step of transmitting the electromagnetic energy includes first passing it through openings 16 in the wall 17 of electrical and thermal insulation 14. The step of application of electromagnetic energy is either by monopolar or bipolar circuitry relative to the tissue and the bodily fluids of the animal or human 13. The claims which follow seek to protect the technique and apparatus for providing an electrosurgical tip that significantly reduces the adherence of coagulated tissue protein by minimizing surface temperature with a low surface free energy conductive tip.

5

What is claimed is:

1. An electrosurgical tip 10 for the application of electromagnetic energy in either a monopolar or a bipolar circuit through the tissue and the bodily fluids of an animal or human 13 comprising:

10 an electrically conductive electrode 11 for connection to a source of electromagnetic electrosurgical energy 12 and for transmission of the electromagnetic electrosurgical energy 12 to the tissue and the bodily fluids of the animal or human 13;

15 an electrical and thermal insulator 14 held about the electrically conductive electrode for preventing the flow of electromagnetic and thermal energy from the electrically conductive electrode 11 to the tissue and the bodily fluids;

a surface 15 of the electrical and thermal insulator 14 for contact with the tissue and the bodily fluids of the animal or human 13, the surface 15 having a low surface free energy;

20 openings 16 through the electrical and thermal insulator 14, the openings 16 extending from the electrically conductive electrode 11 to the surface 15 for the passage of electromagnetic electrosurgical energy 12 from the electrically conductive electrode 11 to the tissue and the bodily fluids, and

25 a wall 17 of the electrical and thermal insulator 14 traversing between the surface 15 of the electrical and thermal insulator 14 and the electrically conductive electrode 11 recessed in the openings, the wall 17 of a thickness about the openings and ample to space the electrically conductive electrode from substantially any direct contact with the tissue of the animal or human 13 and to physically isolate heat generated in the electrically conductive electrode due to the
30 passage of energy from the electrically conductive electrode 11 through the openings 16 to the tissue and the bodily fluids of the animal or human 13.

2. The electrosurgical tip 10 for the application of electromagnetic energy to the tissue or bodily fluids of an animal or human 13 of Claim 1 wherein the electrical and thermal insulator 14 is a sheath 18.

35 3. The electrosurgical tip 10 for the application of electromagnetic energy to the tissue or bodily fluids of an animal or human 13 of Claim 2 wherein the sheath 18 is a polymeric substance.

4. The electrosurgical tip 10 for the application of electromagnetic energy to the tissue and the bodily fluids of an animal or human 13 of Claim 2 wherein the sheath 18 is a ceramic substance 19 and the surface 15 thereof is treated to reduce its surface free energy.
- 5 5. The electrosurgical tip 10 for the application of electromagnetic energy to the tissue and the bodily fluids of an animal or human 13 of Claim 3 wherein the wall 17 of the sheath 18 is a porous substance having an open cellular configuration allowing passage of electromagnetic energy from the electrically conductive electrode 11 to the tissue and the bodily fluids and preventing the flow of thermal energy so
10 there is a thermal gradient between the electrically conductive electrode 11 and the surface 15.
6. The electrosurgical tip 10 for the application of electromagnetic energy to the tissue and the bodily fluids of an animal or human 13 of Claim 4 wherein the
15 wall 17 of the sheath 18 is a porous substance having an open cellular configuration allowing passage of electromagnetic energy from the electrically conductive electrode 11 to the tissue and the bodily fluids and preventing the flow of thermal energy so there is a thermal gradient between the electrically conductive electrode 11 and the surface 15.
7. The electrosurgical tip 10 for the application of electromagnetic energy
20 to the tissue and the bodily fluids of an animal or human 13 of Claim 1 wherein the electrically conductive electrode 11 is at least in part metallic having electrical and thermal conductivity and is selected from the group consisting of copper, gold, silver, aluminum, ferrous alloys and alloys thereof.
8. The electrosurgical tip 10 for the application of electromagnetic energy
25 to the tissue and the bodily fluids of an animal or human 13 of Claim 1 wherein the surface 15 is a fluorinated polymer.
9. The electrosurgical tip 10 for the application of electromagnetic energy to the tissue and the bodily fluids of an animal or human 13 of Claim 1 wherein the
30 surface 15 is a material different from that of the sheath 18, the surface 15 having a low surface 15 free energy.
10. The electrosurgical tip 10 for the application of electromagnetic energy to the tissue and the bodily fluids of an animal or human 13 of Claim 1 wherein the surface 15 has a coating having a low surface 15 free energy.

11. The electrosurgical tip 10 for the application of electromagnetic energy to the tissue and the bodily fluids of an animal or human 13 of Claim 1 wherein the coating is lubricous.

12. An electrosurgical tip 10 for the application of electromagnetic energy
5 in either a monopolar or a bipolar circuit through the tissue and the bodily fluids of an animal or human 13 comprising:

an electrically conductive electrode 11 for connection to a source of electromagnetic electrosurgical energy 12 and for transmission of the electromagnetic electrosurgical energy 12 to the tissue and the bodily fluids of the
10 animal or human 13;

a sheath 18 of heat shrinkable polymeric substance as an electrical and thermal insulator 14 held about the electrically conductive electrode for preventing the flow of electromagnetic and thermal energy from the electrically conductive electrode 11 to the tissue and the bodily fluids;

15 a surface 15 of the sheath 18 for contact with the tissue and the bodily fluids of the animal or human 13, the surface 15 having a low surface 15 free energy for contact with the tissue and the bodily fluids;

openings 16 through the sheath 18, the openings 16 extending from the electrically conductive electrode 11 to the surface 15 for the passage of
20 electromagnetic electrosurgical energy 12 from the electrically conductive electrode 11 to the tissue and the bodily fluids, and

a wall 17 of the sheath 18 between the surface 15 and the electrically conductive electrode 11, the wall 17 of a thickness about the openings and ample to space the electrically conductive electrode recessed in the openings from
25 substantially any contact with the tissue of the animal or human 13 and to physically isolate heat generated in the electrically conductive electrode due to the passage of energy from the electrically conductive electrode 11 through the openings 16 to the tissue and the bodily fluids of the animal or human 13.

13. An electrosurgical tip 10 for the application of electromagnetic energy
30 in either a monopolar or a bipolar circuit through the tissue and the bodily fluids of an animal or human 13 comprising:

an electrically conductive electrode 11 for connection to a source of electromagnetic electrosurgical energy 12 and for transmission of the

electromagnetic electrosurgical energy 12 to the tissue and the bodily fluids of the animal or human 13;

a ceramic substance 19 as an electrical and thermal insulator 14 about the electrically conductive electrode for preventing the flow of electromagnetic and thermal energy from the electrically conductive electrode 11 to the tissue and the bodily fluids, the ceramic substance 19 of a thickness about the openings and ample to space the electrically conductive electrode recessed in the openings from substantially any direct contact with the tissue of the animal or human 13 and to physically isolate heat generated in the electrically conductive electrode due to flow of electromagnetic energy through the electrically conductive electrode 11;

a sheath 18 of a heat shrinkable polymer for surrounding the ceramic substance 19 and for contact with the tissue and the bodily fluids of the animal or human 13;

a surface 15 on the sheath 18 having a low surface free energy for contact with the tissue and the bodily fluids;

openings 16 through the sheath 18 and the ceramic substance 19, the openings 16 extending from the electrically conductive electrode 11 through the surface 15 for the passage of electromagnetic electrosurgical energy 12 from the electrically conductive electrode 11 to the tissue and the bodily fluids.

14. A method of making an electrosurgical tip 10 for the application of electromagnetic energy in either a monopolar or a bipolar circuit through the tissue and the bodily fluids of an animal or human 13 having the steps of:

connecting an electrically conductive electrode 11 to a source of electromagnetic electrosurgical energy 12;

covering the electrically conductive electrode 11 with an electrical and thermal insulator 14 having a surface;

providing openings 16 in the electrical and thermal insulator 14, the openings 16 extending therethrough from the electrically conductive electrode 11 for permitting passage of electromagnetic electrosurgical energy 12 from the electrically conductive electrode 11 to the tissue and the bodily fluids;

providing the surface 15 with a low surface free energy;

extending the openings 16 through the surface 15;

providing a wall 17 in the electrical and thermal insulator 14 between the surface 15 and the electrically conductive electrode 11;

making the wall 17 of a thickness about the openings and ample to space the electrically conductive electrode recessed in the openings from
5 substantially any direct contact with the tissue and of the animal or human 13, and

isolating physically the heat generated in the electrically conductive electrode due to the passage of energy from the electrically conductive electrode 11 through the openings 16 to the tissue and the bodily fluids of the animal or human
13.

10 15. The method of making an electrosurgical tip 10 for the application of electromagnetic energy of Claim 14 wherein the step of covering is performed by heat shrinking a polymeric tube placed over the electrically conductive electrode 11.

15 16. The method of making an electrosurgical tip 10 for the application of electromagnetic energy of Claim 15 wherein the step of providing the openings 16 is performed before heat shrinking the tube.

17. The method of making an electrosurgical tip 10 for the application of electromagnetic energy of Claim 15 wherein the step of providing the openings 16 is performed after heat shrinking the tube.

20 18. A method of using an electrosurgical tip 10 that is electrically and thermally insulated but has openings 16 for passage of and the application of electromagnetic energy in either a monopolar or a bipolar circuit through the tissue and the bodily fluids of an animal or human 13 having the steps of:

placing in close proximity to the tissue and the bodily fluids of the animal or human 13 a surface 15 of the electrical and thermal insulator 14;

25 transmitting the electromagnetic electrosurgical energy through the openings 16 to the tissue and the bodily fluids of the animal or human 13;

delivering electromagnetic electrosurgical energy through openings in a wall of the electrical and thermal insulation from the electrically conductive electrode recessed in the openings to a surface of the wall;

30 spacing the electrically conductive electrode recessed in the openings from substantially any direct contact with the tissue of the animal or human with the wall of a thickness about the openings ample to provide thermal insulation, and cleaning tissue and bodily fluids from the surface 15.

19. The method of using the electrosurgical tip 10 of Claim 18 wherein the step of application of electromagnetic energy is either by monopolar or bipolar circuitry relative to the tissue and the bodily fluids of an animal or human 13.

20. An electrosurgical tip 10 for the application of electromagnetic energy
5 in either a monopolar or a bipolar circuit through the tissue and the bodily fluids of an animal or human 13 comprising:

a metallic electrically and thermally conductive electrode for connection to an electrosurgical generator proximally and for transmission of the electromagnetic electrosurgical energy 12 to the tissue and the bodily fluids of the animal or human
10 13 distally;

a sheath 18 of heat shrinkable fluorinated polymeric substance as an electrical and thermal insulator 14 held about the metallic electrically and thermally conductive electrode for preventing the flow of electromagnetic and thermal energy from the metallic electrically and thermally conductive electrode to the tissue and the
15 bodily fluids;

a smooth surface of the sheath 18 for contact with the tissue and the bodily fluids of the animal or human 13, the surface 15 having a low surface free energy;

openings 16 through the sheath 18, the openings 16 extending from
20 the metallic electrically and thermally conductive electrode to the smooth surface for permitting the passage of electromagnetic electrosurgical energy 12 in the form of arcs from the metallic electrically and thermally conductive electrode to the tissue and the bodily fluids, and

a wall 17 of the sheath 18 between the smooth surface and the
25 metallic electrically and thermally conductive electrode, the wall 17 of a thickness about the openings and adequate to space the metallic electrically and thermally conductive electrode recessed in the openings from substantially any direct contact with the tissue and the bodily fluids of the animal or human 13 and to physically isolate heat generated in the electrically conductive electrode due to the emission of
30 arcs from the metallic electrically and thermally conductive electrode through the openings 16 to the tissue and the bodily fluids of the animal or human 13.

FIG. 1

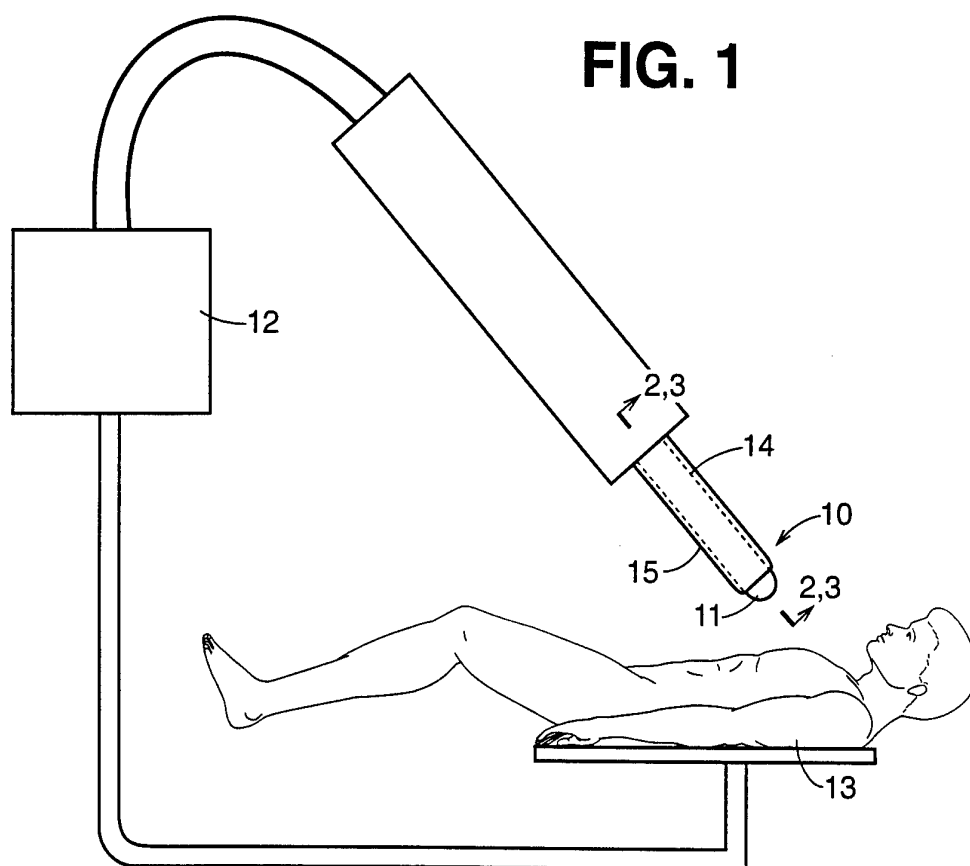

FIG. 2

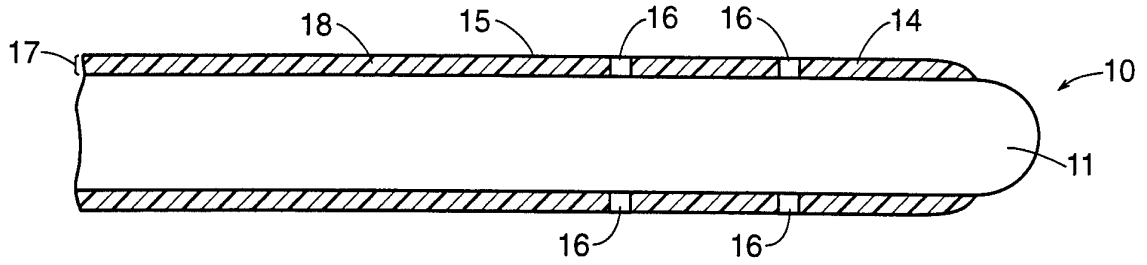

FIG. 3

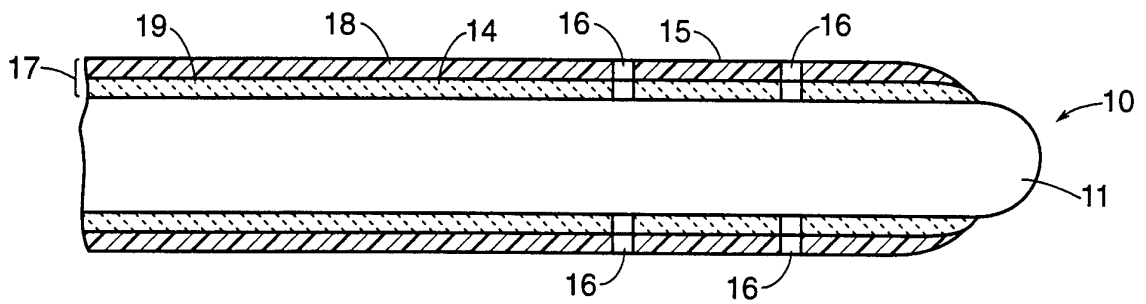
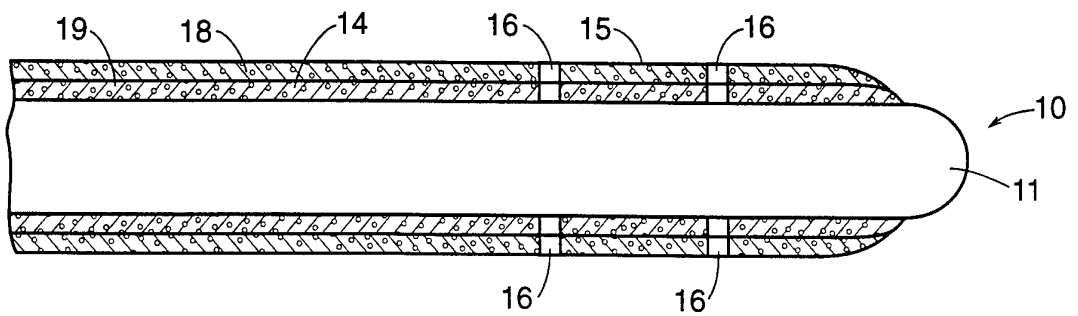

FIG. 4



INTERNATIONAL SEARCH REPORT

Intern al Application No
PCT/IB 94/00353

A. CLASSIFICATION OF SUBJECT MATTER IPC 6 A61B17/39				
According to International Patent Classification (IPC) or to both national classification and IPC				
B. FIELDS SEARCHED				
Minimum documentation searched (classification system followed by classification symbols) IPC 6 A61B				
Documentation searched other than minimum documentation to the extent that such documents are included in the fields searched				
Electronic data base consulted during the international search (name of data base and, where practical, search terms used)				
C. DOCUMENTS CONSIDERED TO BE RELEVANT				
Category °	Citation of document, with indication, where appropriate, of the relevant passages	Relevant to claim No.		
A	US,A,4 314 559 (ALLEN) 9 February 1982 cited in the application see abstract ----	1, 12, 13, 20		
A	US,A,5 151 102 (KAMIYAMA) 20 September 1992 see abstract; figures 3-5 ----	1, 12-14, 20		
A	EP,A,0 067 680 (RAYCHEM CORP.) 22 December 1982 see abstract; figure 2 ----	1, 12-14, 20		
A	EP,A,0 479 482 (MEGADYNE) 8 April 1992 -----			
<input type="checkbox"/> Further documents are listed in the continuation of box C.				
<input checked="" type="checkbox"/> Patent family members are listed in annex.				
° Special categories of cited documents :				
<table style="width: 100%; border: none;"> <tr> <td style="width: 50%; border: none; vertical-align: top;"> *A* document defining the general state of the art which is not considered to be of particular relevance *E* earlier document but published on or after the international filing date *L* document which may throw doubts on priority claim(s) or which is cited to establish the publication date of another citation or other special reason (as specified) *O* document referring to an oral disclosure, use, exhibition or other means *P* document published prior to the international filing date but later than the priority date claimed </td> <td style="width: 50%; border: none; vertical-align: top;"> *T* later document published after the international filing date or priority date and not in conflict with the application but cited to understand the principle or theory underlying the invention *X* document of particular relevance; the claimed invention cannot be considered novel or cannot be considered to involve an inventive step when the document is taken alone *Y* document of particular relevance; the claimed invention cannot be considered to involve an inventive step when the document is combined with one or more other such documents, such combination being obvious to a person skilled in the art. *&* document member of the same patent family </td> </tr> </table>			*A* document defining the general state of the art which is not considered to be of particular relevance *E* earlier document but published on or after the international filing date *L* document which may throw doubts on priority claim(s) or which is cited to establish the publication date of another citation or other special reason (as specified) *O* document referring to an oral disclosure, use, exhibition or other means *P* document published prior to the international filing date but later than the priority date claimed	*T* later document published after the international filing date or priority date and not in conflict with the application but cited to understand the principle or theory underlying the invention *X* document of particular relevance; the claimed invention cannot be considered novel or cannot be considered to involve an inventive step when the document is taken alone *Y* document of particular relevance; the claimed invention cannot be considered to involve an inventive step when the document is combined with one or more other such documents, such combination being obvious to a person skilled in the art. *&* document member of the same patent family
A document defining the general state of the art which is not considered to be of particular relevance *E* earlier document but published on or after the international filing date *L* document which may throw doubts on priority claim(s) or which is cited to establish the publication date of another citation or other special reason (as specified) *O* document referring to an oral disclosure, use, exhibition or other means *P* document published prior to the international filing date but later than the priority date claimed	*T* later document published after the international filing date or priority date and not in conflict with the application but cited to understand the principle or theory underlying the invention *X* document of particular relevance; the claimed invention cannot be considered novel or cannot be considered to involve an inventive step when the document is taken alone *Y* document of particular relevance; the claimed invention cannot be considered to involve an inventive step when the document is combined with one or more other such documents, such combination being obvious to a person skilled in the art. *&* document member of the same patent family			
Date of the actual completion of the international search <div style="text-align: center; font-size: 1.2em;">10 February 1995</div>		Date of mailing of the international search report <div style="text-align: center; font-size: 1.2em;">21.02.95</div>		
Name and mailing address of the ISA European Patent Office, P.B. 5818 Patentlaan 2 NL - 2280 HV Rijswijk Tel. (+31-70) 340-2040, Tx. 31 651 epo nl, Fax: (+31-70) 340-3016		Authorized officer <div style="text-align: center; font-size: 1.2em;">Papone, F</div>		

INTERNATIONAL SEARCH REPORT

Information on patent family members

Intern. Application No PCT/IB 94/00353

Patent document cited in search report	Publication date	Patent family member(s)	Publication date
US-A-4314559	09-02-82	DE-A- 3045202	27-08-81
		FR-A- 2471403	19-06-81
		GB-A- 2066104	08-07-81
		JP-A- 56091743	24-07-81
US-A-5151102	29-09-92	JP-A- 3004847	10-01-91
		JP-A- 4033653	05-02-92
		DE-A, C 4017626	06-12-90
		FR-A, B 2647683	07-12-90
EP-A-0067680	22-12-82	US-A- 4483338	20-11-84
		AT-T- 10430	15-12-84
		GB-A, B 2101893	26-01-83
		JP-A- 57211344	25-12-82
		US-A- 4566183	28-01-86
EP-A-0479482	08-04-92	US-A- 5100402	31-03-92
		AU-B- 637755	03-06-93
		AU-A- 8450891	09-04-92
		CA-A- 2052657	06-04-92
		JP-A- 6339485	13-12-94