



G. W. ROBERTSON.  
STATION INDICATOR.

No. 523,919.

Patented July 31, 1894.

Fig: 3.

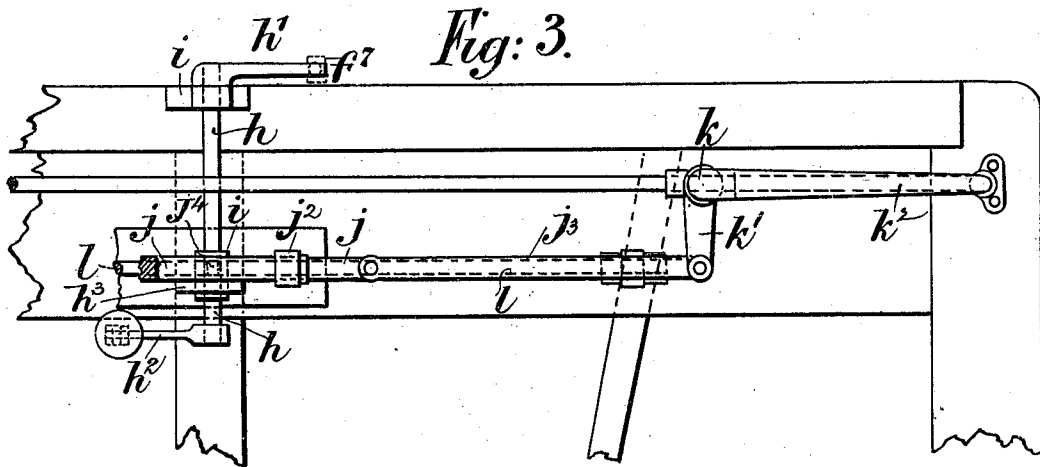
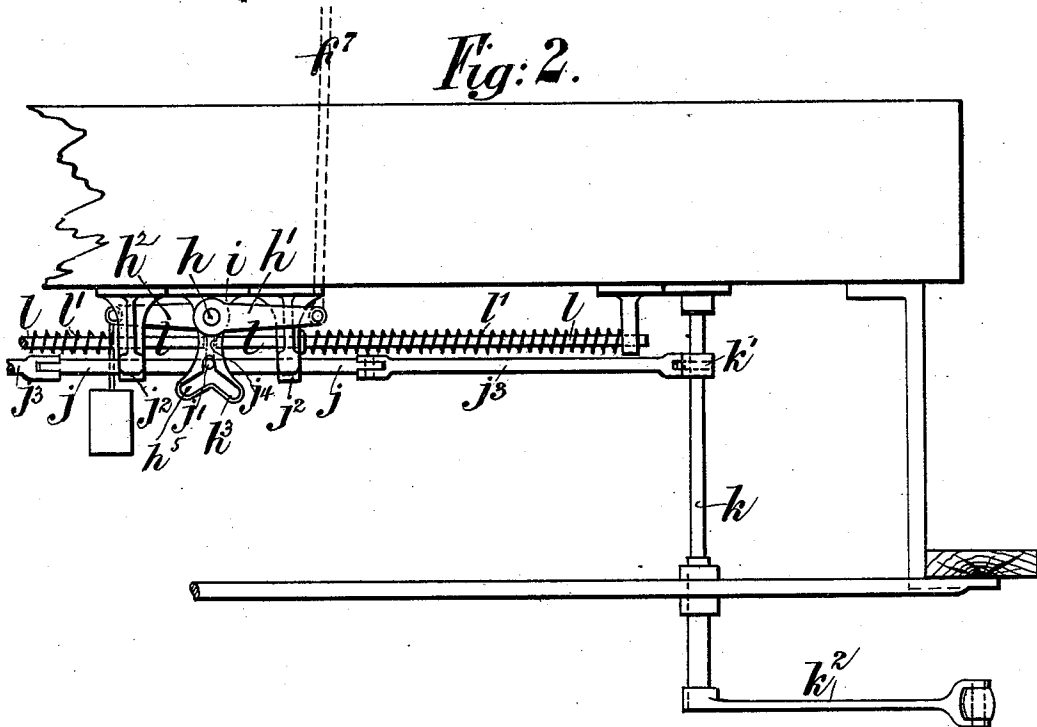

Fig: 2.



Witnesses:  
Walter E. Allen  
S. Allen.

Inventor:  
George Washington Robertson.  
By Knight Bros  
Attorneys

G. W. ROBERTSON.  
STATION INDICATOR.

No. 523,919.

Patented July 31, 1894.

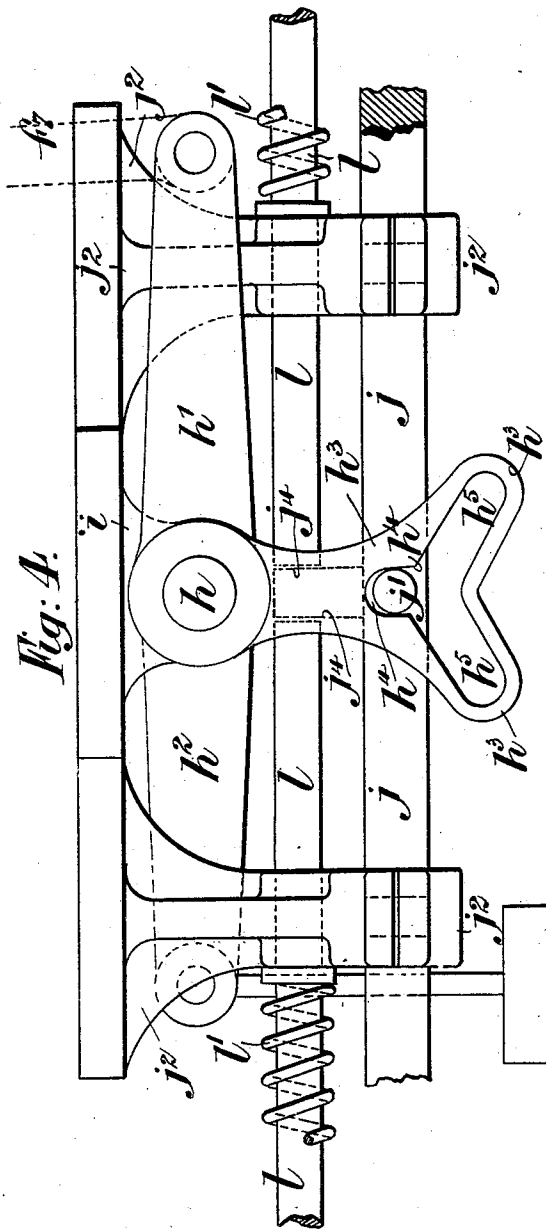

Fig. 4.

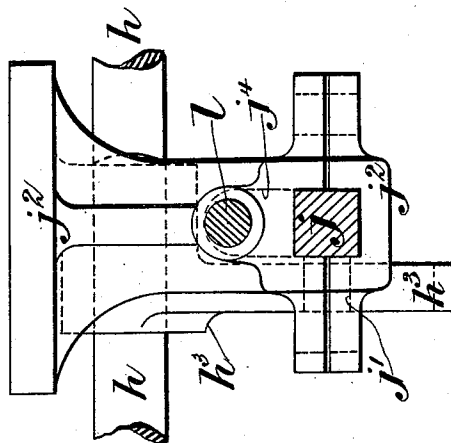

Fig. 5.

Witnesses:  
Walter E. Allen.  
S. Allen.

Inventor:  
George Washington Robertson.  
By Knight Bros  
Attorneys.

G. W. ROBERTSON.  
STATION INDICATOR.

No. 523,919.

Patented July 31, 1894.

Fig: 6.

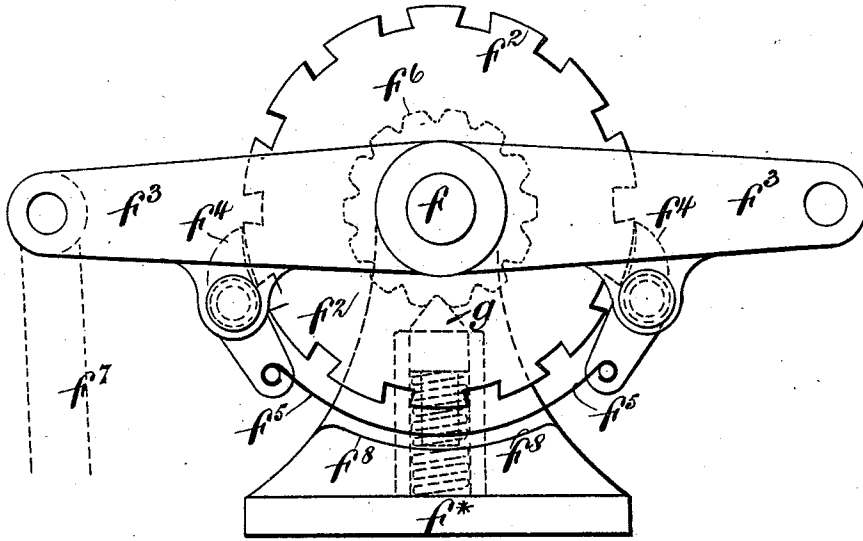
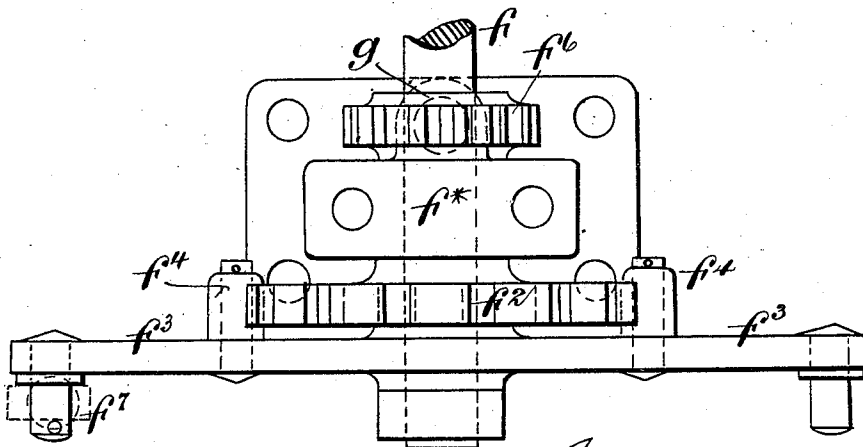

Fig: 7.



Witnesses.  
Walter E. Allen.  
S. Allen.

f Inventor:  
George Washington Robertson.  
By Knight Bros  
Attorneys.

(No Model.)

10 Sheets—Sheet 5.

G. W. ROBERTSON.  
STATION INDICATOR.

No. 523,919

Patented July 31, 1894.

Fig. 8.

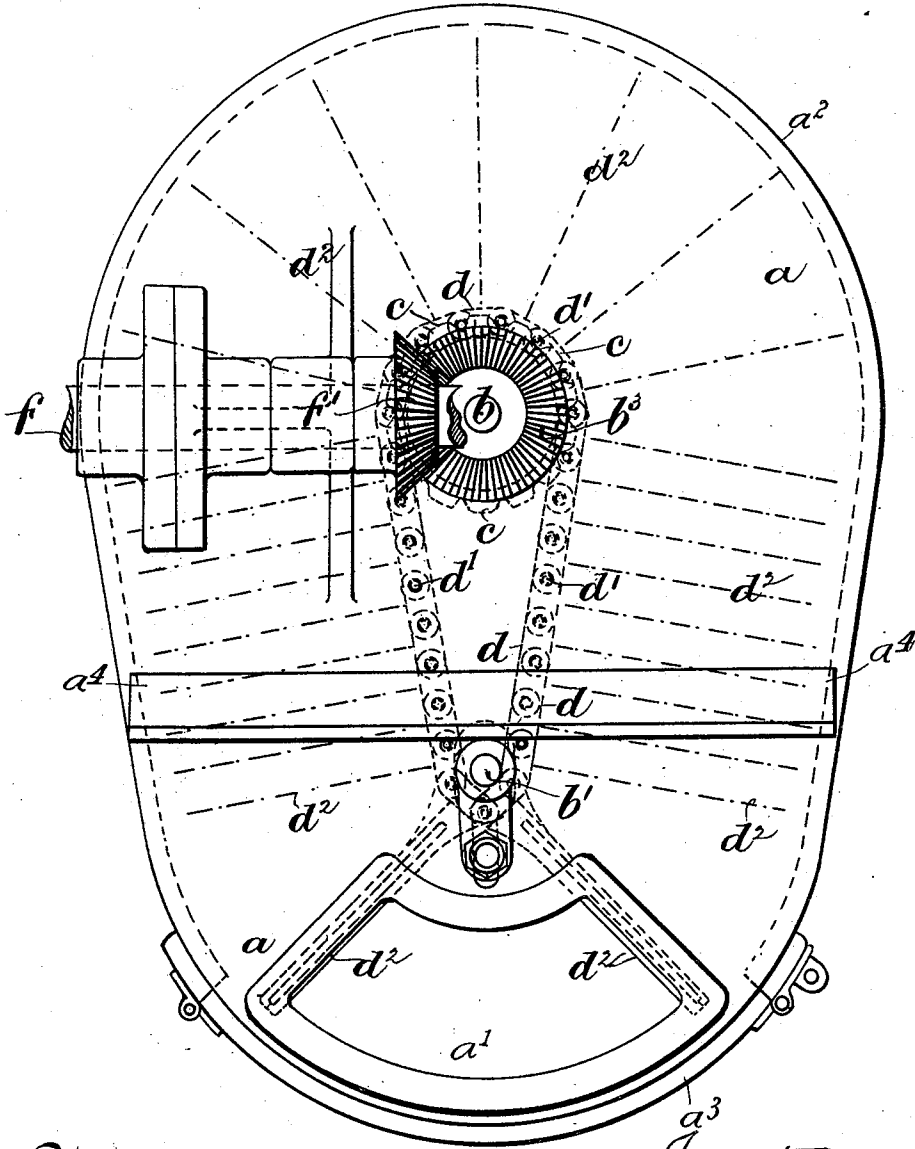

Witnesses:  
Walter E. Allen  
S. Allen.

Inventor:  
George Washington Robertson.  
By  
Knight & Co.  
Attorneys.

G. W. ROBERTSON.  
STATION INDICATOR.

No. 523,919.

Patented July 31, 1894.

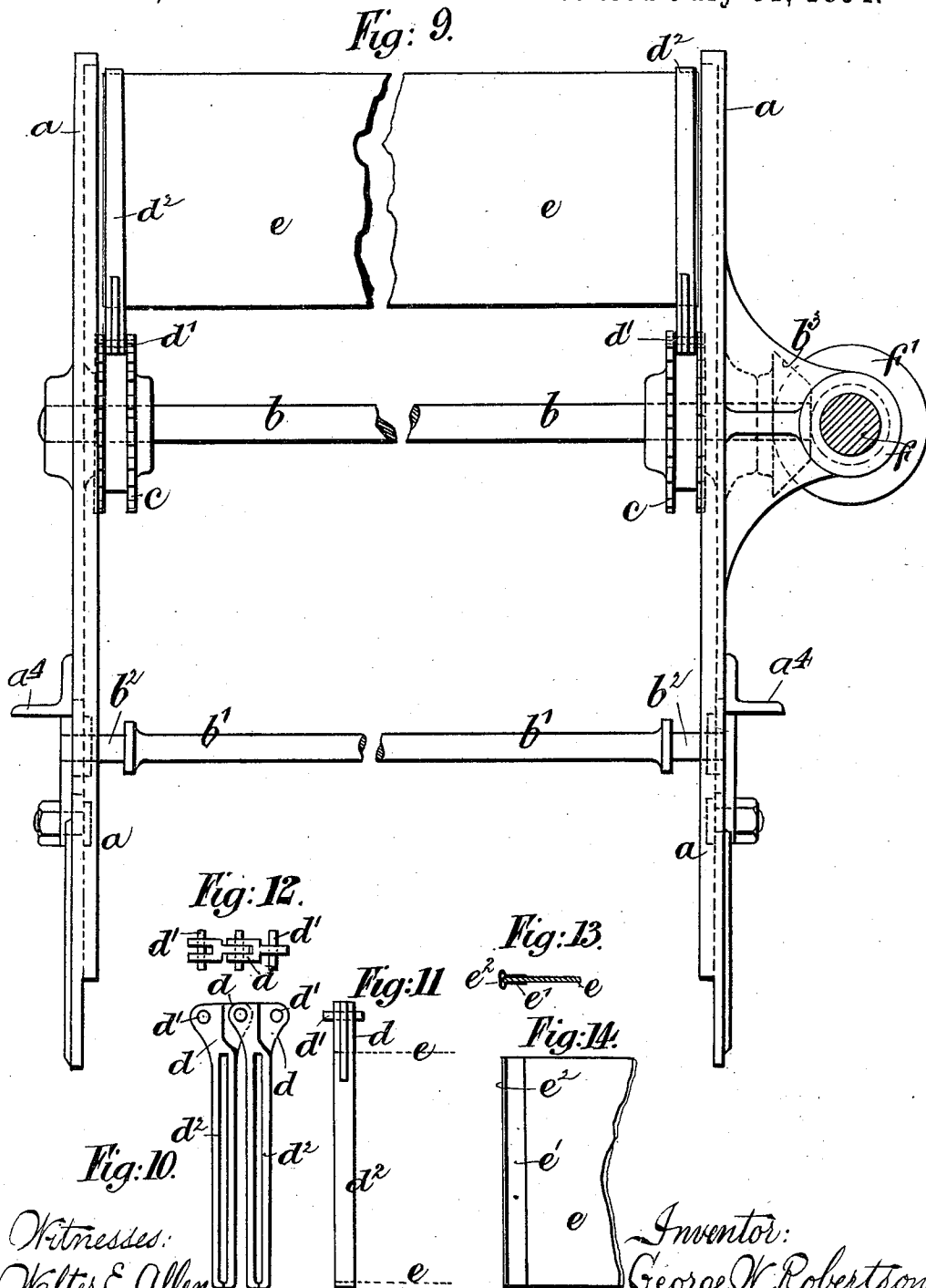

Witnesses:  
 Walter E. Allen  
 S. Allen

Inventor:  
 George W. Robertson  
 By *Knigh Bros.*  
 Attorneys.

G. W. ROBERTSON.  
STATION INDICATOR.

No. 523,919.

Patented July 31, 1894.

Fig. 22.

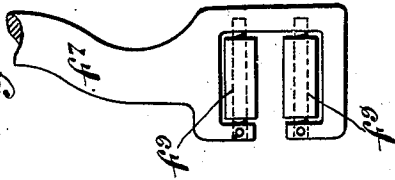

Fig. 21.

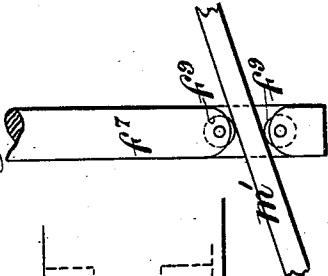

Fig. 15.

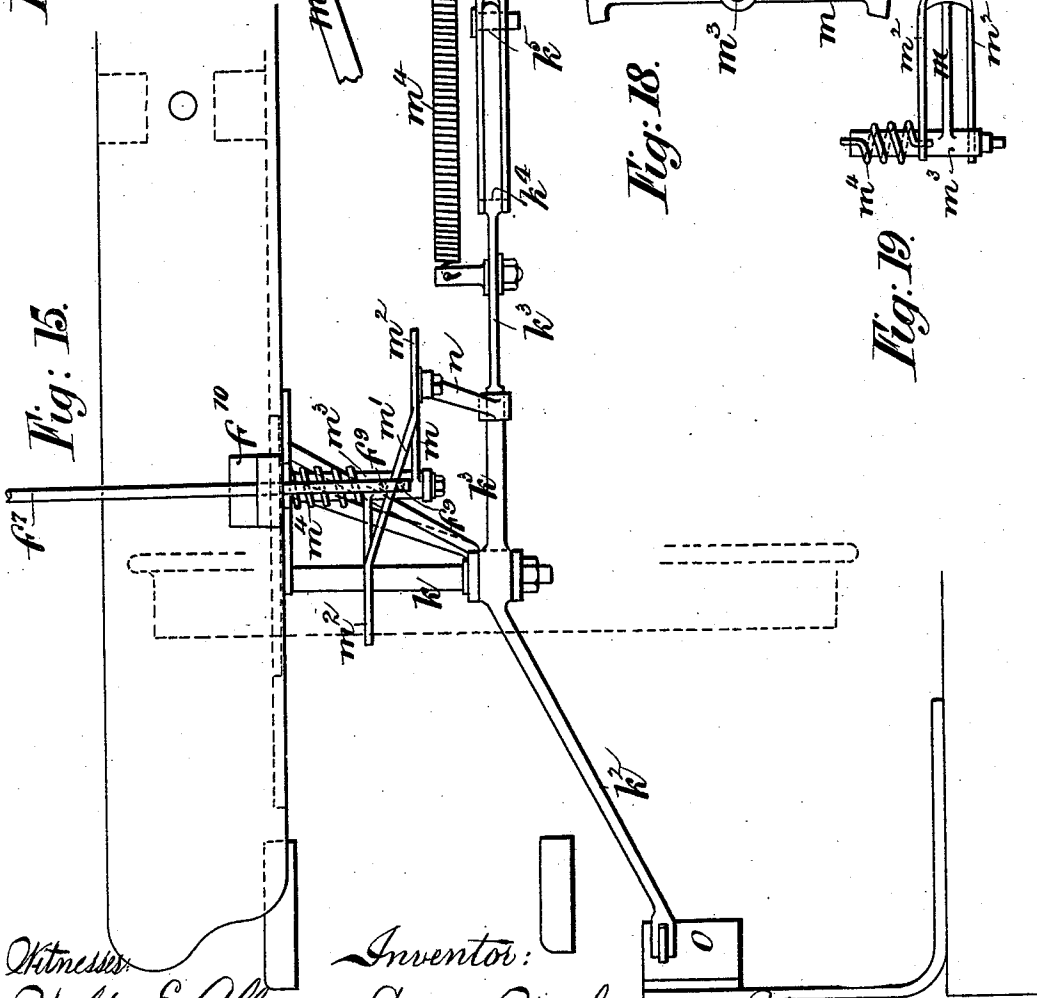

Fig. 20.

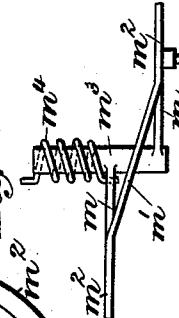

Fig. 18.

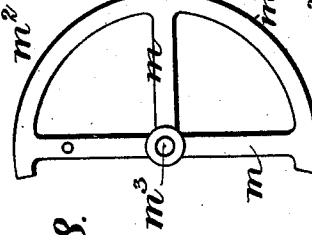
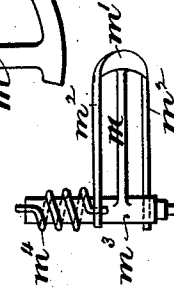

Fig. 19.



Witnesses:  
Walter E. Allen.  
Sadie Allen.

Inventor:  
George Washington Robertson.  
By Knight & Co. Attorneys.



(No Model.)

10 Sheets—Sheet 9.

G. W. ROBERTSON.  
STATION INDICATOR.

No. 523,919.

Patented July 31, 1894.

*Fig. 17.*

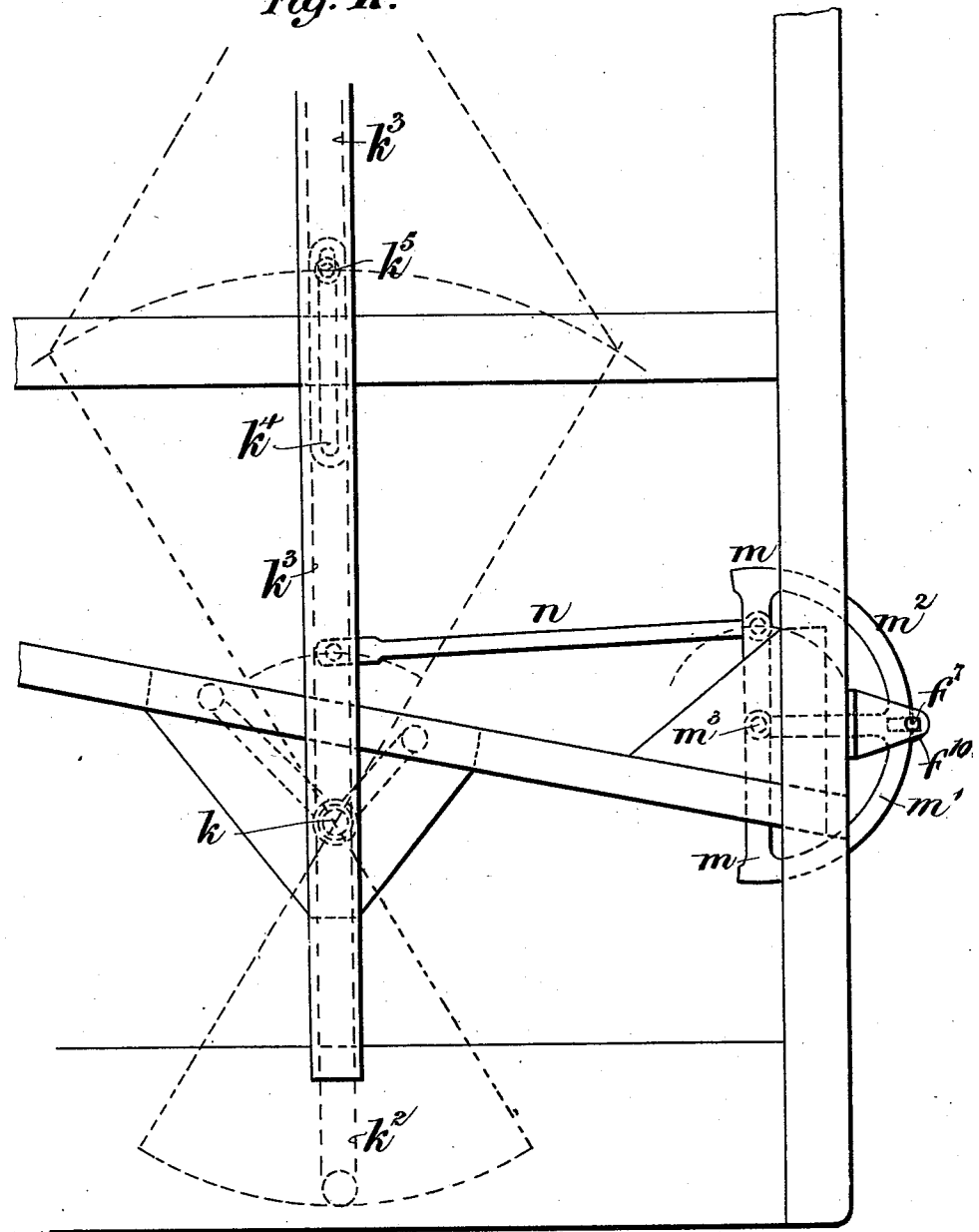

*Witnesses:*  
*Walter E. Allen.*  
*S. Allen*

*Inventor:*  
*George Washington Robertson*  
*By* *Smith Bros*  
*Attorneys*

G. W. ROBERTSON.  
STATION INDICATOR.

No. 523,919.

Patented July 31, 1894.

Fig. 23.

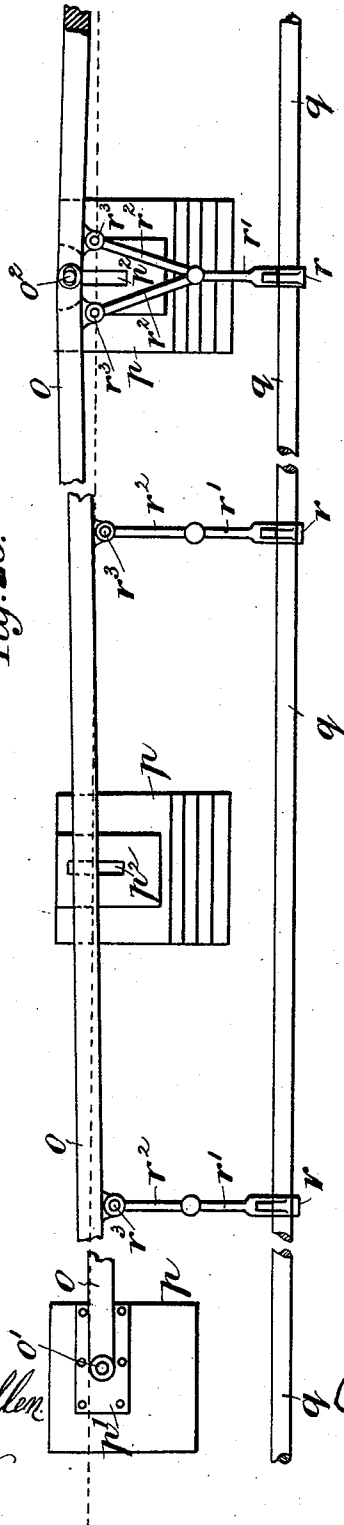

Fig. 24.

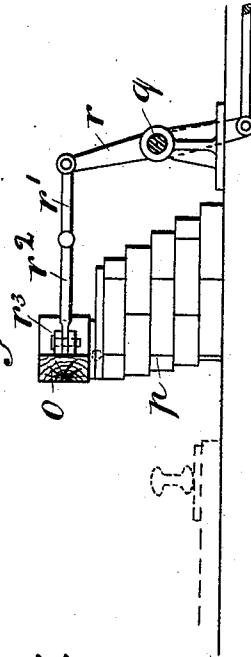
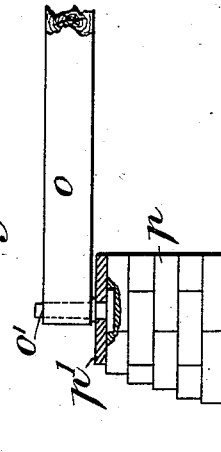

Fig. 25.



Witnesses:  
 Walter E. Allen  
 S. Allen.

Inventor:  
 George Washington Robertson  
 By Knight Bros  
 Attorneys.

# UNITED STATES PATENT OFFICE.

GEORGE W. ROBERTSON, OF LONDON, ENGLAND.

## STATION-INDICATOR.

SPECIFICATION forming part of Letters Patent No. 523,919, dated July 31, 1894.

Application filed October 24, 1893. Serial No. 489,029. (No model.) Patented in England January 2, 1893, No. 1.

To all whom it may concern:

Be it known that I, GEORGE WASHINGTON ROBERTSON, a subject of the Queen of Great Britain, residing at Haverstock Hill, London, in the county of Middlesex, England, have invented certain new and useful Improvements in Station-Indicators, (for which I have obtained Letters Patent in England, No. 1, of January 2, 1893,) of which the following is a specification.

The invention relates to improvements upon an invention for which I obtained a patent in the United States of America, dated November 3, 1891, and numbered 462,588, and the present improvements are represented in the accompanying drawings, in which—

Figure 1 is an end view of a railway carriage fitted with the improved station indicating apparatus. Fig. 2 is an end view and Fig. 3 is an under side view of the parts connecting the prime mover with the vertical connecting rod at the end of the carriage. Fig. 4 is an elevation and Fig. 5 is a cross section of some of the parts shown in the previous figures. Fig. 6 is an elevation and Fig. 7 is a plan of parts at end of shaft on top of carriage. Fig. 8 is an end view of indicator. Fig. 9 is a side view of parts of the indicator. Figs. 10 and 11 are elevations and Fig. 12 is a plan or end view of part of the indicator chain, and Fig. 13 is a sectional edge view and Fig. 14 is a side view of part of an indicator card. Fig. 15 is an end view, Fig. 16 is a side view and Fig. 17 is a plan, of part of a railway carriage showing applied thereto a modification of parts for giving motion from the prime mover to the vertical rod at end of carriage. Figs. 18, 19 and 20 are a plan and two elevations of cam communicating motion from prime mover to said vertical rod, and Figs. 21 and 22 are two elevations of lower part of vertical rod. Fig. 23 is a plan showing one method of constructing and operating my movable cams or inclines. Fig. 24 is a cross section of same and Fig. 25 is a detail view showing one of the end studs or axes.

*a a* are the indicator side frames.

*bb'* are two shafts mounted in the frames *a a*.

*cc* are chain wheels fixed on the shaft *b*.

*dd* are chains passing around the chain wheels with their pins *d'* resting in the notches

of the chain wheels; these chains also pass around the necks *b<sup>2</sup>* of the shaft *b'* so as to keep them properly distended. Each link of the chains is provided with a divided arm *d<sup>2</sup>* to receive the metallic edge *e'* of the tablet *c*, said edge *e'* being formed with projections or flanges *e<sup>2</sup>* on its sides to fit against the outer edges of the arms *d<sup>2</sup>*. The two parts of the arms *d<sup>2</sup>* are sprung toward each other and they are bent at their free ends so as to meet and thereby hold the tablets *c* securely and yet permit of ready change. Each tablet *c* will carry the name of a station and an advertisement as heretofore.

The indicator side frames *a a* are provided with glazed apertures *a' a'* to admit light to the interior of the indicator. The frames *a a* are connected together by a metal casing *a<sup>2</sup>*, while the segmental shaped bottom of the indicator frame is provided with a hinged glazed door *a<sup>3</sup>* to enable the indicator tablets *c* to be seen and to permit of access to the interior of the indicator.

The lower part of the indicator passes through the carriage roof to the interior of the carriage and the indicator is fixed in position by means of two flanges *a<sup>4</sup>* thereon resting on and fixed to carriage roof.

On one end of the shaft *b* is fixed a bevel wheel *b<sup>3</sup>* which meshes with a bevel wheel *f'* fixed on the shaft *f* which latter extends along the carriage top and is fitted with as many wheels *f'* as there are indicators to a carriage. One end of the shaft *f* has a double acting ratchet wheel *f<sup>2</sup>* and a notched wheel *f<sup>6</sup>* fixed thereon and a double ended pawl lever *f<sup>3</sup>* mounted loosely thereon, the pawls *f<sup>4</sup>* of which act on opposite sides of the ratchet wheel *f<sup>2</sup>* and are sprung toward the edge of the latter by a spring *f<sup>5</sup>*. The shaft *f* is mounted in standards *f<sup>\*</sup>* and a spring dog *g* mounted in a socket in the end standard *f<sup>\*</sup>* acts in connection with the notched wheel *f<sup>6</sup>* to insure correct adjustment and firm holding of the chain of tablets.

By the above arrangement all the indicators of a carriage are enabled to be operated by a single ratchet wheel *f<sup>2</sup>* and notched wheel *f<sup>6</sup>* fixed on the end of shaft *f* and one double pawl lever mounted on said shaft, instead of, as heretofore, employing a set of such parts to each indicator.

Either end of the pawl lever  $f^3$  is connected by rod  $f^7$  to a lever  $h'$  fixed on one end of a shaft  $h$  mounted in brackets  $i$  on the under side of the carriage and provided at its other end with a counterbalance lever  $h^2$ . The rod  $f^7$  is connected to one or the other end of the pawl lever  $f^3$  according to the direction in which the train is required to travel. On the shaft  $h$  is fixed a cam lever  $h^3$  within the cam slot of which works a stud  $j'$  fixed in a bar  $j$ . This bar  $j$  is mounted in brackets  $j^2$  and is pin-jointed to links  $j^3$ , which latter are also pin-jointed to levers  $k'$  fixed on shafts  $k$  one at each side of the carriage. On the lower end of each shaft  $k$  is fixed a prime motion lever  $k^2$ , the outer end of which is acted upon by an incline or cam  $o$  fixed on the permanent way or to a platform or other structure alongside the line.

$l$  are two centering rods which are acted upon by springs  $l'$ ; these rods bear at their inner ends against a projection  $j^4$  on the bar  $j$  and act after each action of the apparatus to restore the parts to the central position shown in the drawings.

The cam slot in the lever  $h^3$  has a central short slot  $h^4$  within which the pin  $j'$  on the bar  $j$  normally rests, and such cam slot  $h^4$  is connected to inclined cam slots  $h^5$ . Thus, when the bar  $j$  is moved in either direction by a prime motion lever  $k^2$ , the pin  $j'$  first works against one or other side of the cam slot  $h^4$  and thereby gives a definite amount of motion to the cam lever  $h^3$  and consequently to the indicator chains, then, on a prime mover  $k^2$  receiving more motion than that required to work the indicators, the stud  $j'$  will move out of the cam slot  $h^4$  and will move along one or other of the cam slots  $h^5$ , which latter at such time will be in a horizontal direction; the cam lever  $h^3$  will thereby, after having received its proper motion, be held firm notwithstanding that the stud  $j'$  continues to travel a certain distance.

When one of the pawls  $f^4$  is rising to give motion to the ratchet wheel  $f^2$ , the other pawl descends and, in order to prevent the descending pawl from interfering with the rotation of the wheel  $f^2$ , its tail is pressed inward by the fixed cam  $f^8$  so as to raise its nose away from the edge of the wheel  $f^2$ .

I will now describe the modification shown at Figs. 15 to 22 for communicating a certain fixed amount of motion from the prime mover  $k^2$  to the vertical rod  $f^7$ . In this arrangement the rod  $f^7$  is mounted in guides  $f^{10}$  fixed to end of carriage, and the lower end of such rod is provided with anti-friction rollers  $f^9$  to fit against the upper and lower sides of the edge of a cam formed segment  $m$  whose cam edge is formed with an incline  $m'$  and a straight part  $m^2$  at each end of such incline. This cam formed segment  $m$  is mounted on an axis  $m^3$  and it is connected by link  $n$  with an arm  $k^3$  of one of the prime movers  $k^2$ , which arms  $k^3$  are connected together by means of a slot  $k^4$  in one and a pin  $k^5$  from the other pass-

ing through said slot thereby causing them to move in unison; consequently the arm  $k^3$  connected to the cam formed segment  $m$  will give motion to such segment when either prime mover  $k^2$  is acted upon by an operative cam or incline  $o$ . Springs  $m^4$  restore the cam segment  $m$  to its normally central position after each action thereof.

It should be understood that the prime motion levers  $k^2$  and the fixed operating cams  $o$  are so arranged that the prime mover may receive more motion than is necessary to give the required motion to the indicator chain, but, by the interposition of a lost motion arrangement between the prime mover and the vertical rod  $f^7$ , the latter receives only the exact amount of motion required to correctly operate the indicators, while the prime mover may receive a variable amount of motion depending upon the sway of the train caused by the wear of the wheels and line and other causes.

The invention also relates to means for enabling the indicators to be quickly shifted so as to indicate the proper stations when the carriages are caused to run on different lines or branches. Thus supposing a train sometimes runs from end to end of line A and sometimes branches off therefrom on to line B; the indicator tablets are so arranged that the names of all the stations appear in succession thereon, say, those of line A and then those of line B. Now on running on line A the names of its stations will be successively shown by the indicators until the junction with line B is reached, and even then would continue to be indicated in succession at the different stations on line B unless means were devised for obviating the same. For this purpose there are arranged at or near the junction a series of cams or inclines  $o$  near to each other and of a number corresponding with that of the stations on line A which are not passed by the train; these cams or inclines  $o$  are made movable, as shown at Figs. 23, 24 and 25, and they are constructed and operated as follows:—The movable cams or inclines  $o$ , which may be supported upon suitable columns of brickwork or masonry  $p$ , are at their outer ends mounted on studs or axes  $o'$  fixed in plates  $p'$  fixed to the brickwork or masonry  $p$ . At their inner or adjacent ends they are provided with hinges  $o^2$  which are loosely fitted so as to allow the slight endwise motion of each part of the cam or incline when it is being pushed into or withdrawn from the working position. At the back of the cams or inclines  $o$  I mount in suitable bearings a shaft  $q$  capable of receiving rotary motion by means of links and levers or in any other suitable manner. This shaft  $q$  has fixed thereon a number of levers  $r$  the outer ends of which are connected by means of connecting rods  $r'$  to guided thrust rods  $r^2$  connected to the back of the movable cams or inclines  $o$  by hinged joints  $r^3$ . The levers  $r$  are of various lengths according to their position in relation to the

cams or inclines  $o$ , those nearer the center  $o^3$  being longer than those nearer the pivoted ends  $o'$ . The cams  $o$  have anti-friction rollers running in grooves upon the metal plates  $p^2$ .

5 By the above arrangement an attendant at the side of the line can readily place the cams or inclines  $o$  in or out of position for operation. Thus when the train from line A begins to run on line B the series of movable  
10 cams or inclines  $o$  are placed in position to act on the prime movers  $k^2$ , thus causing the names of stations of line A from the junction to the end of said line and first station on line B to be passed in rapid succession by the indicators, so that the latter shall, before arriv-  
15 ing at the first station on line B, indicate the name of said station and then successively the names of the remainder of the stations on said line B. By means of these movable cams  
20 or inclines  $o$ , means may be readily provided to suit various arrangements of traffic.

Having fully described my invention, what I desire to claim and secure by Letters Patent is—

25 1. In a station indicator, the combination of a casing containing the indicating tablets, suitable means for intermittently moving the said tablets, consisting of a shaft carrying the  
30 tablets, a bevel wheel on said shaft, a shaft carrying a bevel wheel for engagement with the tablet carrying shaft a double-acting ratchet-wheel fixed on the end of said shaft, and a lever carrying a pair of pawls for en-  
35 gagement with said ratchet-wheel mounted on said shaft, and suitable means for moving said lever consisting of a rod connected with the lever and a prime mover connected with the rod and adapted to be engaged by a series of  
40 cams located along the line of travel substantially as shown and for the purpose set forth.

2. In a station indicator, the combination of a casing containing the indicating tablets, suitable means for intermittently moving the  
45 said tablets consisting of a shaft carrying the tablets, a bevel wheel on said shaft, a shaft carrying a bevel wheel for engagement with the tablet carrying shaft and a double-acting ratchet-wheel and a cog-wheel fixed on  
50 said shaft, a lever carrying a pair of pawls for engagement with said ratchet-wheel and mounted on said shaft, a spring dog for engagement with said cog-wheel, and a prime mover adapted to be engaged by a series of cams lo-  
55 cated along the line of travel, connected with the lever carrying the pawls substantially as and for the purpose set forth.

3. In a station indicator the combination of

a casing containing a number of indicating tablets suitable mechanism connected there-  
60 with for intermittently moving the said tablets, and suitable mechanism for operating the intermittent mechanism consisting of a cam-lever  $h^3$  provided with the cam slots  $h^4$ ,  $h^5$  and carried by a shaft  $h$ , a suitable connection  
65 between the shaft  $h$  and the intermittent mechanism, and a prime mover connected with the cam-lever and adapted to be engaged by a series of cams located along the line of travel substantially as and for the purpose  
70 set forth.

4. In a station indicator, the combination of a casing containing a series of indicating tablets, suitable mechanism connected therewith  
75 for intermittently moving the tablets, a cam-lever  $h^3$  connected with said mechanism for operating it, a prime mover connected with the said cam-lever, and a pair of spring-pressed bars bearing on said cam-lever for normally holding it in position substantially  
80 as and for the purpose set forth.

5. In a station indicator, the combination of a casing containing a number of indicating tablets suitable mechanism connected there-  
85 with for intermittently moving them, a prime mover connected with said mechanism, and adapted to engage a series of cams located along the line of travel, and suitable means for adjusting said cams consisting of a series  
90 of pivoted levers of different lengths, connected with said cams, said levers being connected with and operated by a shaft substantially as and for the purpose set forth.

6. In a station indicator, the combination with a prime mover  $k^2$ , of a lost motion cam, connections between such prime mover and  
95 said cam, connections between such cam and a vertical rod  $f^7$  at the end of the carriage, a longitudinal shaft  $f$  along the carriage top, a double acting ratchet wheel  $f^2$  fixed on shaft  $f$ , a double ended pawl lever  $f^3$  mounted  
100 loosely on shaft  $f$ , a notched wheel  $f^6$  fixed on shaft  $f$ , a spring dog  $g$  acting with said wheel  $f^6$ , and bevel wheels  $f'$  on shaft  $f$  giving motion to indicators by means of bevel wheels  $b^3$  fixed on indicator shafts  $b$ , substantially as  
105 herein shown and described and for the purpose stated.

GEO. W. ROBERTSON.

Witnesses:

B. J. B. MILLS,

CLAUDE K. MILLS,

Patent Agents, 23 Southampton Buildings,  
London, W. C.