

V. WASEM.

Improvement in Wagon-Beds.

No. 129,769.

Patented July 23, 1872.

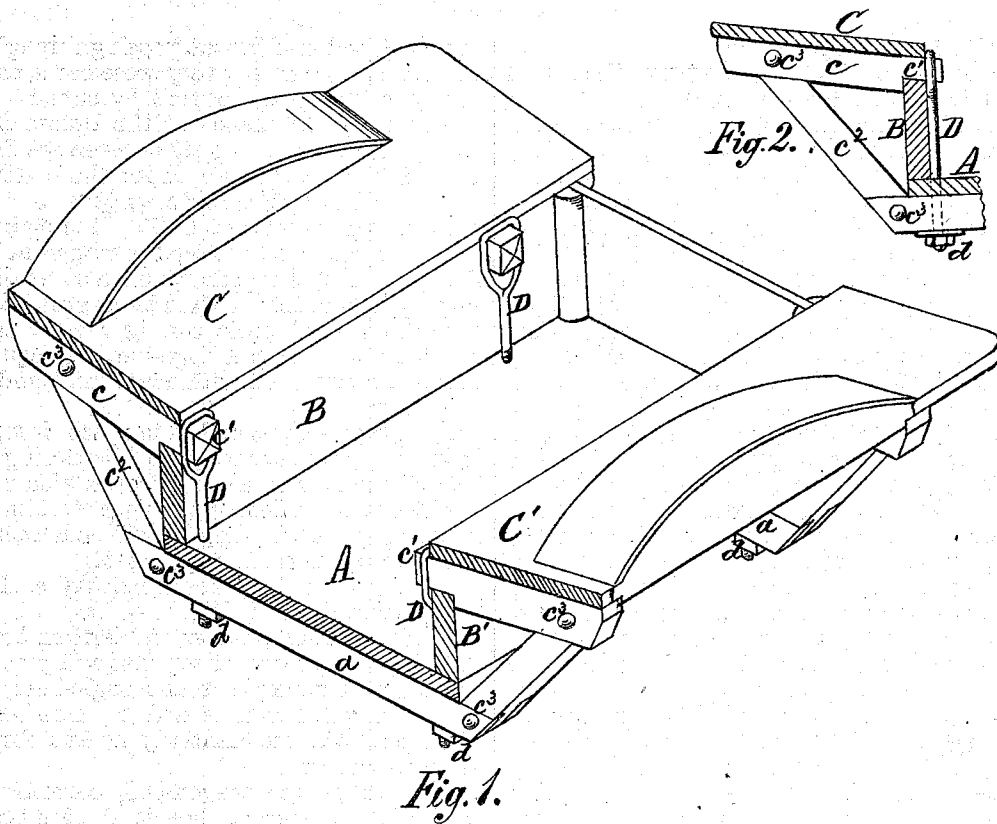

WITNESSES:

*Robert Burns.*  
*J. W. Herthel.*

INVENTOR:

*Valentin Waseem.*  
*per. Herthel & Co.*  
*attys.*

# UNITED STATES PATENT OFFICE.

VALENTIN WASEM, OF FAYETTEVILLE, ILLINOIS.

## IMPROVEMENT IN WAGON-BEDS.

Specification forming part of Letters Patent No. 129,769, dated July 23, 1872.

### *To all whom it may concern:*

Be it known that I, VALENTIN WASEM, of Fayetteville, in the county of St. Clair and State of Illinois, have invented a new and useful Improved Wagon-Bed; and I do hereby declare that the following is a full and true description thereof, reference being had to the accompanying drawing, and to the letters of reference marked thereon.

This invention relates to wagons for farm use—the hauling, carrying, and transporting of hay, oats, wheat, and grain crops in general. This invention consists in the peculiar construction of forming the wagon-bed, so that its several frame parts can be taken apart, removed, as well as replaced, from and upon the wagon-wheels; also, the wagon-bed here shown is grain-tight, preventing the loss of seed and grain, and otherwise possesses advantages of lessening the labor incurred in the use of the ordinary wagon-beds for this purpose.

To enable those herein skilled to make and use my said improvements, I will now more fully describe the same, referring to—

Figure 1 as a sectional isometrical view; to Fig. 2 as a detail section.

A is the bottom boards; B B', the respective side boards; C C', the respective top side boards. To the bottom A are firmly secured cross-bars *a*. The side boards B B' are placed on top of the bottom bed A. To the top side boards C C', respectively, are properly secured the under cross-bars *c*, the projecting tenons *c'* of which are fitted to engage proper mortises in the side boards B B', as shown in Figs. 1 and 2. The under cross-bars *c* are mortised to receive the tenon of the angle-bars *c''*, the latter, further, by their tenons, being fitted to engage the mortise of each of the cross-bars *a*, as indicated in the figures. The several mortise-joints are secured together by pins *d*. D are iron braces, which are formed to clamp the

tenons *c'*, and said braces, passing through the bottom A, as well as every cross-bar *a*, can be firmly and properly secured by nuts *d*. (See the figures.) By means of the braces D the respective side and top side boards are firmly braced to the cross-bars under the bottom or bed A. The angle-bars *c''* strengthen and support the top side board C C'. It is plain the several parts constituting the wagon-bed are firmly connected together, and also by disengaging the pins the mortised joints are loosened and the several parts can be readily taken apart as well as put together, as required. The bed is provided with usual front and tail boards.

My improved wagon-bed is space-clear, and is grain-tight, preventing the scattering and loss of grain, and the readiness with which the bed can be taken apart for protection and housing, as well as simplicity in construction, are advantages readily apparent.

Having thus fully described my said improvements, what I claim is—

1. The cross-bars under the bottom boards or bed, joined, by mortise-joints and pins and braces, with under bars and angle-bars, that support the side boards and top side boards of wagon-beds, substantially as and for the purpose set forth.

2. An improved wagon-bed, consisting of the bed A, cross-bar *a*, braces D, side boards B B', angle-bars *c''*, under bars *c*, and top side boards C C', all said parts being arranged and constructed so as to be taken apart and put together, as herein shown and for the purpose set forth.

In testimony of said invention I have hereunto set my hand.

VALENTIN WASEM.

Witnesses:

WILLIAM W. HERTHEL,  
ROBERT BURNS.