

No. 775,115.

PATENTED NOV. 15, 1904.

J. M. McCLELLON.
LOCOMOTIVE BOILER.

APPLICATION FILED JULY 11, 1903.

NO MODEL.

4 SHEETS—SHEET 1.

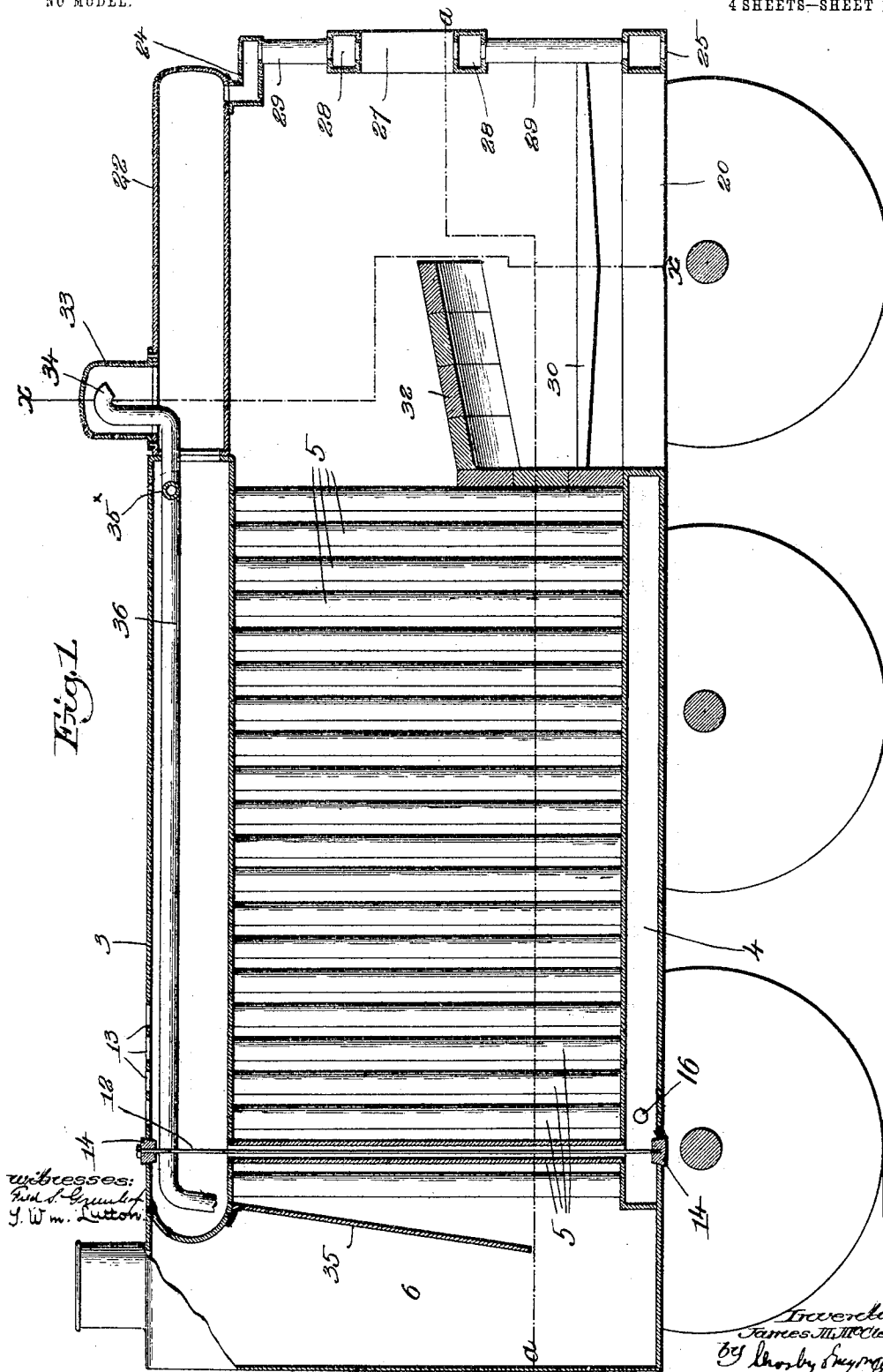

J. M. McCLELLON.
LOCOMOTIVE BOILER.
APPLICATION FILED JULY 11, 1903.

NO MODEL.

4 SHEETS—SHEET 2.

Fig. 2.

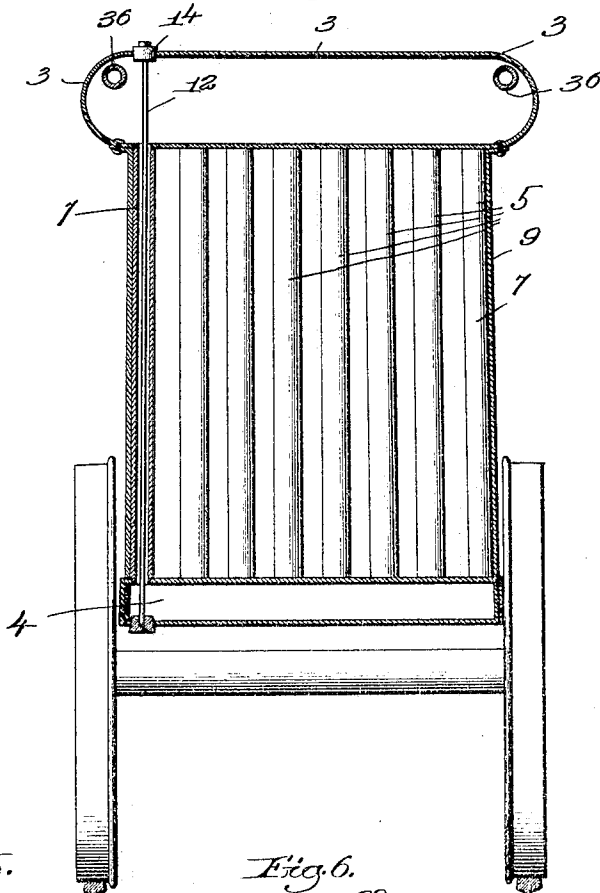

Fig. 5.

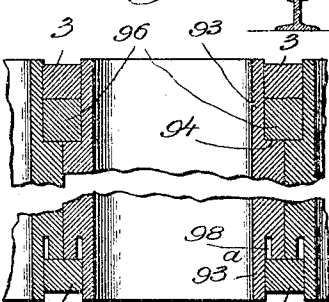

Fig. 6.

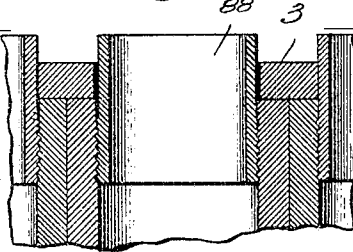

Fig. 7.

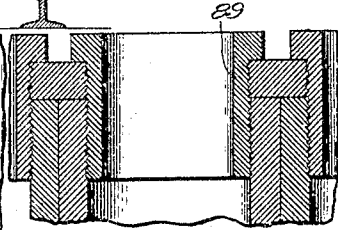
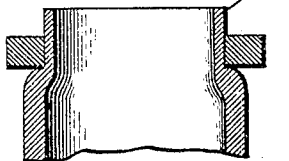

Fig. 8.



Witnesses:
 Fred S. Grunlof.
 J. Wm. Lutton.

Invention
 James H. McClellon,
 by Wesley Ferguson
 attys.

J. M. McCLELLON.
LOCOMOTIVE BOILER.

APPLICATION FILED JULY 11, 1903.

NO MODEL.

4 SHEETS—SHEET 3.

Fig. 3.

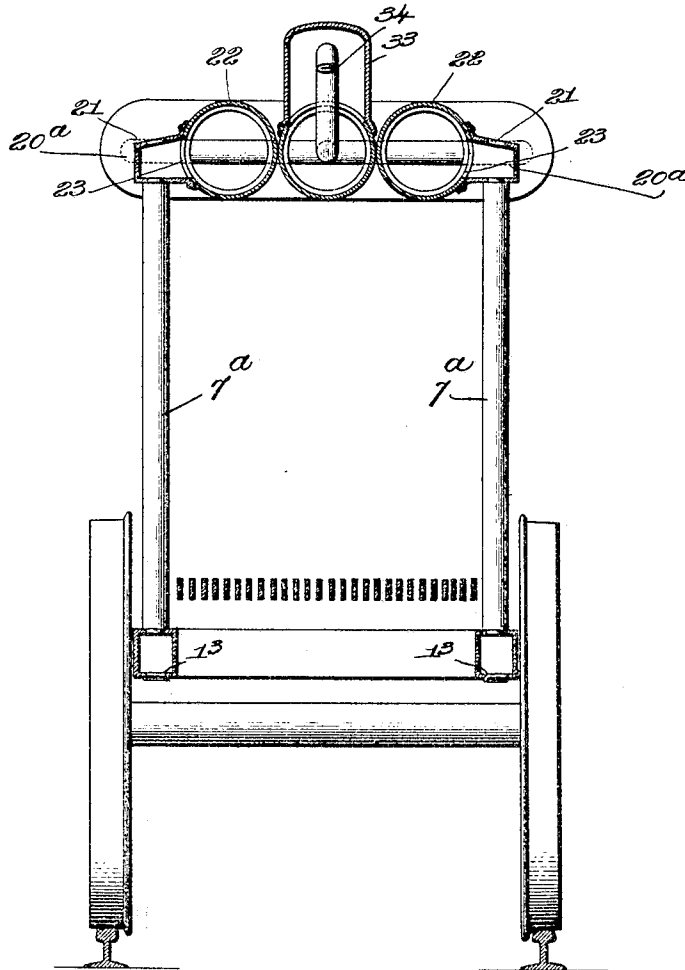

Fig. 9.

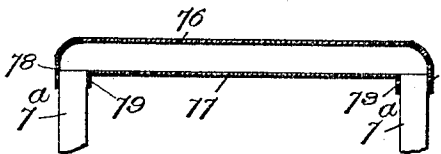
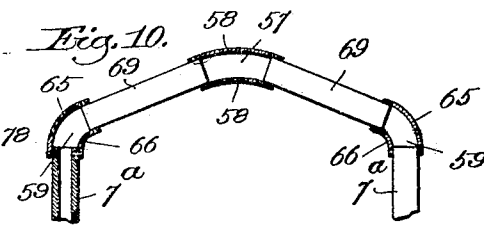

Fig. 10.



Witnesses:

Fred S. Grumbaf.
J. Wm. Luton.

Inventor.
James M. McClellon,
by Densley Ferguson,
attys.

J. M. McCLELLON.
LOCOMOTIVE BOILER.

APPLICATION FILED JULY 11, 1903.

NO MODEL.

4 SHEETS—SHEET 4.

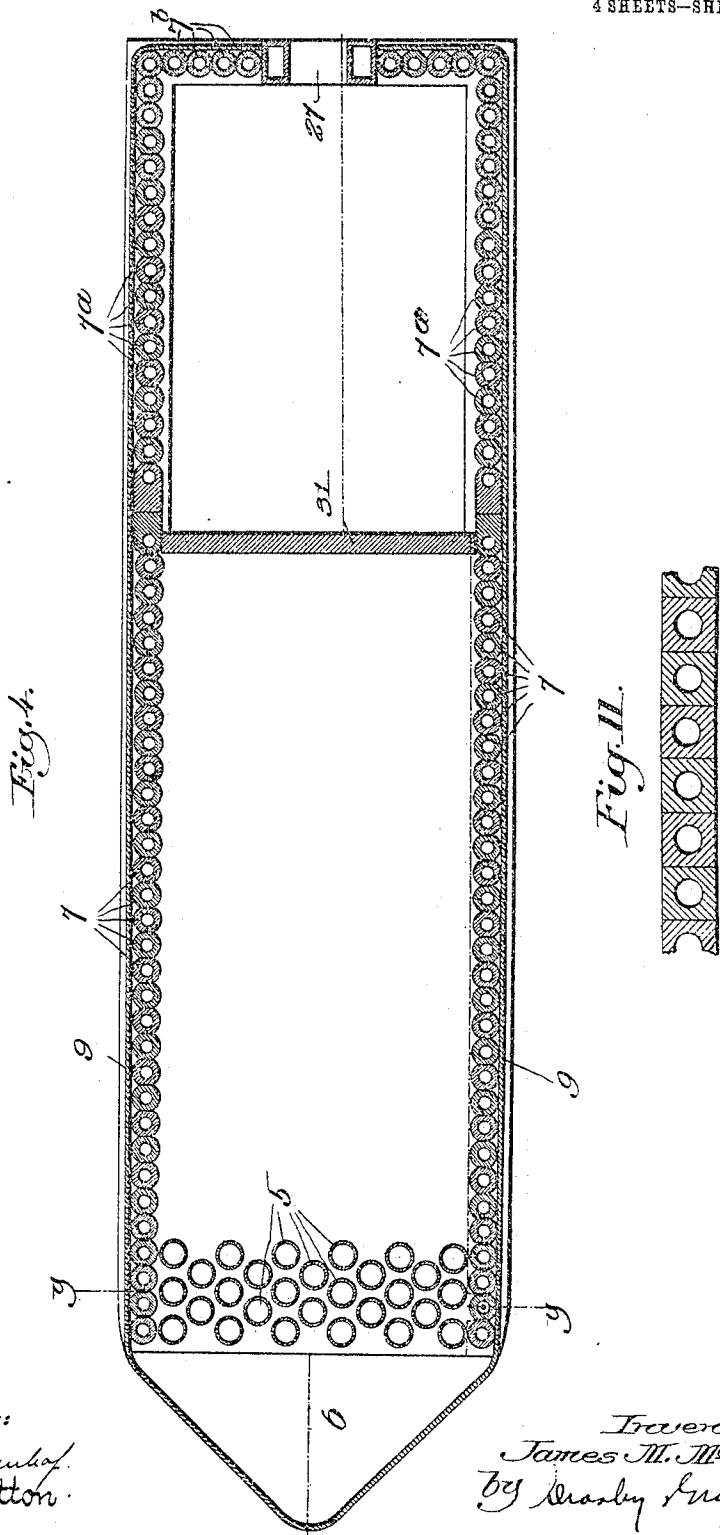

Witnesses:
Fred S. Grunkof.
J. Wm. Sutton.

Inventor:
James M. McClellon,
by Masby Gregory
attys.

UNITED STATES PATENT OFFICE.

JAMES M. McCLELLON, OF EVERETT, MASSACHUSETTS.

LOCOMOTIVE-BOILER.

SPECIFICATION forming part of Letters Patent No. 775,115, dated November 15, 1904.

Application filed July 11, 1903. Serial No. 165,111. (No model.)

To all whom it may concern:

Be it known that I, JAMES M. McCLELLON, a citizen of the United States, residing at Everett, in the county of Suffolk and State of Massachusetts, have invented an Improvement in Locomotive-Boilers, of which the following description, in connection with the accompanying drawings, is a specification, like figures on the drawings representing like parts.

This invention relates to water-tube boilers, and especially to locomotive-boilers of this type, and has for its object to provide a boiler which is simple in construction, easy to repair, and in which the stayed surfaces, especially around the fire-box, are eliminated and which also has a very high efficiency. The stayed surfaces around the fire-box are avoided by making the walls of the fire-box of closely-arranged or engaging water-tubes, which of course do not need to be stayed, and by using drums at the top of the fire-box. The body of the boiler is formed by two shells or water-chambers forming the top and bottom of the flue which connects the fire-box with the smoke-chamber and two rows of closely-arranged water-tubes connecting said shells and which form the sides of the flue. The water-tubes within the flue are arranged substantially vertically and connect the upper and the lower shells. The construction is such that any one of the tubes may be removed without disturbing any of the other tubes, thus simplifying greatly the construction and repair of the boiler. The water-tubes within the flue extend substantially parallel to the general direction in which the products of combustion are displaced as they pass from the fire-box to the smoke-chamber, and the feed-water is introduced into the boiler at or near the point where the products of combustion escape into the smoke-chamber. There is therefore an opposite displacement of water in the water-tubes and products of combustion through the flue, with the result that the coolest water receives its first heat from the cooler gases, and as said water is displaced toward the evaporating-surface it receives heat from gases having a progressively-increasing temperature. The hottest water, or that at the evaporating-surface, therefore receives heat

from the hottest gases, while the coolest water in the boiler is being heated from the cooler gases. By this means I can use the heated products of combustion most economically and increase to a considerable extent the efficiency of the boiler.

Other novel features of my invention will be hereinafter more specifically pointed out, and set forth in the claims.

In the drawings, Figure 1 is a vertical central section of a locomotive-boiler embodying my improvements. Fig. 2 is a section on the line *yy*, Fig. 1. Fig. 3 is a section on the line *xx*, Fig. 1. Fig. 4 is a horizontal section on the line *aa*, Fig. 1. Figs. 5, 6, 7, and 8 are details showing different ways in which the water-tubes at the sides of the flue may be expanded into the headers. Figs. 9 and 10 show modified forms of fire-box construction. Fig. 11 shows the form of water-tubes used in the construction illustrated in Figs. 9 and 10.

3 designates an upper shell forming a steam and water chamber, and 4 designates a lower shell forming a water-chamber. These chambers are suitably connected by a plurality of water-tubes 5, which are expanded into the lower side of the upper shell 3 and the upper side of the lower shell 4 in any suitable or approved manner. The space between these two shells forms the flue connecting the fire-box, which will be hereinafter described, and the smoke-chamber 6. The sides of the flue are formed by two rows of closely-arranged or engaging water-tubes 7, as best seen in Fig. 4, said tubes being secured in some suitable way to the upper and lower shells 3 and 4. These tubes may have any desired contour or shape, those illustrated being substantially round and having comparatively thick walls. These tubes are shown as extending substantially vertical and when of the form shown in Fig. 4 may either be placed so that the convex surface of one engages the convex surface of the other, or the engaging sides of the tubes may be flattened by being planed off or otherwise, as shown in the drawings. I prefer this latter construction, because better joints between adjacent pipes can be made.

Outside of each row of tubes 7 I prefer to

place a suitable covering of asbestos or other non-heat-conducting material and a finishing or protecting sheet 9. Since the tubes 7 of each row engage each other, it would be im-
 5 possible to expand their ends into the shells 3 and 4 in the usual way without first reduc-
 ing their ends, for otherwise so much of the material of the shells at the point where the tubes enter would be removed as to unduly
 10 weaken them. Various expedients may be resorted to to secure these tubes to the shells without unduly weakening the latter, and in Figs. 5 to 8 I have shown some ways in which this may be accomplished. In Fig. 5 I have
 15 illustrated the ends of each tube 7 as being necked or reduced in size, as at 93 93^a. This construction makes the necked or reduced portions of the tubes which are inserted through the shells thin enough so that they
 20 can be expanded and also leave sufficient metal between adjacent holes in the shells to give the requisite strength. Where this construction is employed, I propose to make the neck or reduced portion 93 at one end of the
 25 tube longer than the neck 93^a at the opposite end of the tube. I do this so as to facilitate the insertion or removal of any individual tube, for with this construction it will be seen that the longer necked portion 93 may be
 30 first inserted through the aperture in the shell 3 and the tube raised until the shoulder 94 engages said shell. When in this position, the lower end of the tube may be brought over the corresponding aperture in the lower
 35 shell and then the tube moved laterally into the position shown in Fig. 5. To hold the tubes steady, I propose to insert a filling-piece 96 between the shoulder 94 and the shell 3. Each of the tubes is illustrated as having
 40 an annular groove 98 at the base of the neck portion 93^a, the object of which construction is to permit the neck portion to be expanded both on the outside and inside of the shell. Without such groove the thickness of the
 45 wall of the tube below the neck would prevent its being expanded. In Fig. 6 I have illustrated a slightly-different way of securing the tubes in place. In this construction the tubes are of a length to set between the shells, and their ends butt against the shells.
 50 In inserting the tube it is placed between the shells and in line with the apertures through the shells, and thereafter a suitable bushing or sleeve 88 is inserted through the shell and screw-threaded into the end of the tube.
 55 Said bushing projects through the shell sufficiently so that it can be expanded therein. Fig. 7 is somewhat similar to Fig. 6, in that the tubes 7 are of a length to be received between the shells; but the form of the bushing
 60 89 is somewhat different. This latter bushing is screw-threaded into both the shell and the tube. In Fig. 8 the ends of the tube are made smaller, as at 86, by spanning or drawing
 65 the tubes and said ends expanded into the

shell. Various other ways of accomplishing this object may be employed without departing from the invention.

From the above it will be seen that the top and bottom of the flue is formed by the upper and lower shells 3 and 4, and the sides of the flue is formed by the rows of water-tubes 7. I will preferably construct the upper side of the shell 3 and the lower side of the shell 4 with a plurality of apertures or holes 13, which
 70 are normally filled by suitable plugs 14.

I propose to place one hole opposite the end of each tube 5, so that by removing the plugs 14 access may be had to the tubes 5 for the purpose of removing any individual tube and
 80 replacing it by a fresh tube. This construction permits any individual tube 5 to be removed without in any way disturbing the other tubes. I also propose to place these apertures 13 opposite the end of each of the tubes
 85 7, so that any one of the latter may be removed without disturbing the others.

The shells 3 and 4 may be stayed in any suitable way, though I prefer the construction shown in Fig. 1, wherein stay-rods 12 extend
 90 through the water-tubes 5 and are connected at their ends to the plugs 14.

16 designates the end of the feed-pipe through which the feed-water is delivered to the boiler, it being noted that said water is
 95 delivered to the lower chamber 4. The fire-box I propose to use is also of novel construction. Its top is formed by a plurality of longitudinal drums 22, which are connected at their ends in some suitable way to the end of
 100 the shell 3 and which communicate with said shell. The side walls and also the door end of the fire-box are formed by closely-arranged water-tubes which are connected at their upper ends to the drums and at their lower ends
 105 to suitable headers. The water-tubes at the sides of the fire-box are designated by 7^a and those at the door end by 7^b. The water-tubes 7^a form, in effect, a continuation of the rows of tubes 7, as seen in Fig. 4. These water-tubes may be secured to the drums in a variety of ways. As herein shown, the out-
 110 side drums each have secured thereto a longitudinally-extending header 20^a, to which the upper ends of the tubes 7^a are secured, the lower ends of said tubes being secured to suitable headers 20, which extend along the sides of the bottom of the fire-box. The tubes 7^b are secured at their upper ends to a cross-header 24, which in turn is secured to
 115 the ends of the drums, and the bottom of the tubes 7^b are secured to a cross-header 25. Any appropriate way of securing these tubes 7^a and 7^b at their ends to the headers may be employed. I prefer to provide said headers
 120 with apertures opposite each of the tubes, so that any individual tube may be cut for removal or expanded without disturbing the others. These apertures, it will be understood, will be closed by the suitable plugs 26.
 125
 130

I may make the short tubes 29 above and below the door 27 in the form of drop-tubes, or I may employ suitable headers 28, which form the top and bottom of the door from and to which the tubes 29 are secured.

Grates 30 of any suitable construction are employed, and the space between the headers 20 and 25 is intended to be occupied by any usual ash-pan construction.

The front of the fire-box is partially lined with fire-bricks 31 to prevent the burning coal from coming directly in contact with the tubes 5. I will preferably employ a deflecting-arch 32, of any suitable material, which deflects the heated products of combustion backward and upward against the drums 22. One of the drums, preferably the central drum, has the dome 33 of any suitable construction thereon, in which the end of the steam-pipe 34 terminates and which contains any usual form of throttle-valve. (Not shown.) This pipe 34 extends into the rear end of the shell 3 and is there branched, as at 35, and the two branches 36 taken along the sides of the shell 3, as seen in Fig. 2, and into the smoke-chamber, where they pass to the steam-chests of the cylinders, as usual. By locating the two pipes 36 at the sides of the shell 3 they are carried out of line of any of the pipes 5 or 7.

In the front end of the boiler is arranged a deflecting-plate 35, which deflects the gases downwardly and causes them to enter the lower end of the smoke-chamber 6. It will be understood, of course, that the smoke-chamber has in it the usual spark-arrester and exhaust-nozzle and other parts usually found in the front end of locomotives.

With this construction the heated gases pass first up against the drums 22 and thence along underneath the shell 3. As the deflecting-plate 35 prevents them from passing directly into the smoke-chamber and causes them to pass downwardly along the tubes 5 and into the lower end of the smoke-chamber, the result is that the displacement of the gases is in a downward direction, the hottest gases remaining at the top of the flue and the cooler gases settling to the bottom of the flue and thence passing to the smoke-chamber. The water, however, which is fed into the lower chamber 4 gradually rises as it is heated, and the greatest evaporation occurs when the gases are the hottest. There is therefore a gradual upward displacement of the water and a corresponding downward displacement of the products of combustion, with the result that the cool water entering the boiler first abstracts heat from the cool gases, and as it is gradually heated and rises it takes heat from the hot and hotter gases until at the upper portion of the boiler it is being heated by the hottest gases. By this arrangement a much more economical use of the fuel is obtained than is possible with the ordinary construction.

By using water-tubes to form the sides of the flue I practically obtain water-chambers at the sides of the flue which do not need to be stayed in any way, as water-chambers formed by flat surfaces would have to be. Furthermore, by using drums at the upper end of the fire-box and using the water-tubes to form the sides of the fire-box I do away entirely with all stayed constructions around the fire-box and yet secure a maximum amount of heating-surface.

The only surfaces in my improved boiler which it is necessary to stay are the upper and lower sides of the shells 3 and 4, which are subjected to the action of the hot gases, and these can be easily stayed by means of the stay-bolts 12. The lower side of the shell 3 and the upper side of the shell 4 are properly stayed by the tubes 5 and 7.

A boiler constructed as above described is substantially rectangular in vertical cross-section, and I prefer to make it of such a width that it will set between the drivers of the engine, as seen in Figs. 1, 2, and 3, thus making a boiler the maximum heating-surface of which can be set low upon the engine.

Instead of employing the drums 22 at the top side of the fire-box I may employ either of the constructions shown in Figs. 9 and 10. In Fig. 9 the top of the fire-box is formed by two sheets of metal 76 and 77, forming between them a water-chamber. These sheets of metal extend across the fire-box and are bent downwardly at their ends, as at 78 and 79, and said downwardly-bent ends are secured to the tubes 7 in any suitable way. With this construction it will be necessary to stay each of the sheets 76 and 77. In Fig. 10 the upper ends of the tubes 7 at the sides of the fire-box have secured thereto short curved sheets 65 and 66, which extend the length of the fire-box, and other short tubes, 69, are also secured to these sheets and extend over the top of the fire-box, said latter tubes being secured together by curved sheets 58 at the top of the fire-box. The space between the sheets 65 and 66 forms chambers 59, into which the ends of the tubes 7 and 69 open, and the tubes 69 also open into a chamber 57 between the two sheets or plates 58. Where the constructions shown in Figs. 9 and 10 are employed, I will preferably make the tubes 7 square in exterior cross-section, so that the outer and inner faces of the tubes make a flat surface, to which the sheets may be riveted.

While I have shown one way in which my invention may be embodied, I do not wish to be limited to the particular details of construction shown, as various changes may be made without departing in any way from the invention expressed in the appended claims.

Having described my invention, what I claim as new, and desire to secure by Letters Patent, is—

1. In a locomotive-boiler, a combustion-

- chamber, a smoke-chamber, a horizontal flue connecting said chambers, means to cause a general downward displacement of the products of combustion in said flue, water-tubes extending through the flue in a direction substantially parallel to the general direction of displacement of the products of combustion, and means whereby any water-tube may be removed and replaced by another tube from the exterior of the boiler without disturbing any other tube.
2. In a water-tube locomotive-boiler a combustion-chamber at one end of the boiler, smoke-chambers at the other end of said boiler, a horizontal flue connecting said chambers, means to cause a general downward displacement of the products of combustion in said flue, and vertical water-tubes extending through said flue, and means to admit the water to the boiler at the lower end of the water-tubes.
3. In a locomotive-boiler, an upper shell and a lower shell, said shells extending longitudinally of the boiler and forming between them the flue, and water-tubes connecting said shells.
4. In a locomotive-boiler a horizontal upper shell and a horizontal lower shell, said shells extending longitudinally of the boiler and forming between them the flue, water-tubes connecting said shells, and tie-rods extending through the tubes and connecting the upper surface of the upper shell with the lower surface of the lower shell.
5. In a locomotive-boiler, two parallel shells forming between them a flue, a fire-box at one end of the flue, a smoke-chamber at the other end of the flue, rows of engaging water-tubes connecting said shells at the sides and forming the sides of the flue, and other water-tubes connecting said shells and passing through the flue.
6. A locomotive water-tube boiler having a fire-box at one end thereof, a smoke-chamber at the other end, two parallel shells forming the top and bottom of the flue which connects said fire-box and smoke-chamber, rows of vertical water-tubes which engage each other connecting said shells at their sides and forming the sides of the flue, and other water-tubes connecting said shells and passing through the flue.
7. In a locomotive-boiler, two horizontal shells connected by water-tubes, the space between said shells forming a flue, a combustion-chamber communicating with one end of the flue, and a smoke-chamber with the other end of the flue, means to admit the feed-water to the lower shell, and means to cause a downward movement of the products of combustion as they pass from the combustion-chamber to the smoke-chamber.
8. In a locomotive-boiler, two separate horizontally-extending shells connected by water-tubes, the space between said shells forming a flue, and a fire-box at one end of said flue, said fire-box having its sides formed of engaging water-tubes.
9. In a locomotive-boiler, a fire-box having its sides formed by vertically-extending water-tubes which engage each other, and longitudinally-extending headers at the bottom and top of the fire-box to which said tubes are directly connected.
10. In a locomotive-boiler, headers extending around the bottom and top of the fire-box, and vertical water-tubes connecting said headers and forming the sides of the fire-box.
11. In a locomotive-boiler, headers extending around the bottom and top of the fire-box, and vertical water-tubes connecting said headers and forming the sides of the fire-box, the adjacent tubes engaging each other throughout their full length.
12. A locomotive-boiler having a fire-box at one end and a smoke-chamber at the other connected by a flue, the sides of the flue being formed by engaging water-tubes.
13. A locomotive-boiler having a fire-box and a smoke-chamber connected by a flue, the sides of the flue being formed by a row of vertically-extending water-tubes which engage each other.
14. A fire-box for a boiler having its sides formed by vertically-extending water-tubes which engage each other, and its top by longitudinally-extending drums.
15. In a fire-box for a boiler, a plurality of drums forming the top of the fire-box, and rows of engaging water-tubes forming the sides and one end of the said box.
16. In a locomotive-boiler, a fire-box and a smoke-chamber connected by a flue, the sides of the fire-box and flue being formed by rows of engaging water-tubes.
17. In a water-tube locomotive-boiler, a combustion-chamber at one end, a smoke-chamber at the other end, a horizontal flue connecting said chambers, means to cause a general downward displacement of the products of combustion in said flue, vertical water-tubes extending through the flue, and means to feed water to the lower end of said tubes.
18. In a locomotive-boiler, a fire-box having headers on its sides and one end, both at the top and bottom, and vertical water-tubes connecting said headers and forming the walls of the fire-box.
19. In a locomotive-boiler a fire-box and a smoke-chamber connected by a flue, the sides of the flue and the sides and one end of the fire-box being formed of rows of engaging water-tubes.
20. In a fire-box for a locomotive-boiler, longitudinally-extending drums forming the top of said fire-box, rows of engaging water-tubes forming the sides thereof, and headers secured to the drums and to which said tubes are connected.
21. In a fire-box for a boiler, longitudinally-extending drums forming the top of said fire-box, rows of engaging water-tubes forming the sides thereof, and headers secured to the drums and to which said tubes are connected.

nally-extending drums forming the top of said fire-box, headers connected to said drums at the sides and one end of said fire-box, other headers at the bottom of the fire-box extending along the sides and across said end thereof, and tubes connecting said headers and forming the walls of the fire-box.

22. In a locomotive-boiler, a fire-box and a smoke-chamber connected by a horizontal flue, headers extending along the sides of the flue and fire-box, both at the top and bottom thereof, and vertical water-tubes connected to said headers and forming the sides of the fire-box and flue.

23. In a locomotive-boiler, a fire-box and a smoke-chamber connected by a flue, headers extending along the sides of the fire-box and flue and across the end of the fire-box at the top and bottom thereof, and water-tubes connecting said headers and forming the sides of the flue and the sides and end of the fire-box.

24. In a locomotive-boiler, a fire-box and a smoke-chamber connected by a flue, longitudinally-extending drums forming the top of the fire-box, headers extending along the sides of the fire-box and flue, both at the top and bottom thereof, other headers extending across the end of the fire-box both at the top and bottom, and vertical engaging water-tubes connecting said headers and forming the sides of the flue and the side and end walls of the fire-box.

25. In a water-tube locomotive-boiler, a

combustion-chamber at one end of the boiler, a smoke-chamber at the other end thereof, a horizontal flue connecting said chambers, means to cause a general downward displacement of the products of combustion in said flue, vertical water-tubes extending through the flue, means to admit the water to the boiler at the lower end of the water-tubes, and means whereby any individual water-tube may be removed from the exterior of the boiler.

26. A locomotive-boiler having an upper shell and a lower shell, each extending longitudinally of the boiler, said shells forming between them the flue, water-tubes connecting said shells and situated within the flue, and means whereby any individual water-tube may be removed from the exterior of the boiler without disturbing any other tube.

27. A locomotive-boiler having an upper shell and a lower shell, each extending longitudinally of the boiler, said shells forming between them the flue, and water-tubes connecting said shells, the outer side of each shell having apertures in line with the water-tubes, and removable plugs for said apertures.

In testimony whereof I have signed my name to this specification in the presence of two subscribing witnesses.

JAMES M. McCLELLON.

Witnesses:

JOHN C. EDWARDS,

LOUIS C. SMITH.