



(11) **EP 1 717 061 A3**

(12) **EUROPEAN PATENT APPLICATION**

(88) Date of publication A3:  
**07.02.2007 Bulletin 2007/06**

(51) Int Cl.:  
**B44D 3/12 (2006.01)**

(43) Date of publication A2:  
**02.11.2006 Bulletin 2006/44**

(21) Application number: **06252251.1**

(22) Date of filing: **27.04.2006**

(84) Designated Contracting States:  
**AT BE BG CH CY CZ DE DK EE ES FI FR GB GR  
HU IE IS IT LI LT LU LV MC NL PL PT RO SE SI  
SK TR**  
Designated Extension States:  
**AL BA HR MK YU**

- **Hushka, Charles S. Jr.**  
**Tinley Park,**  
**Illinois 60477 (US)**
- **Choi, Jun Y.**  
**Naperville,**  
**Illinois 60565 (US)**
- **Nania, Frank**  
**Naperville,**  
**Illinois 60565 (US)**
- **Arciniegas, Alfonso**  
**Morton Grove,**  
**Illinois 60053 (US)**

(30) Priority: **29.04.2005 US 119003**  
**29.04.2005 US 119050**

(71) Applicant: **Central Can Company**  
**Chicago IL 60623 (US)**

(72) Inventors:

- **Kline, Terry L.**  
**Wheaton,**  
**Illinois 60187 (US)**

(74) Representative: **Spencer, Michael David et al**  
**Bromhead Johnson**  
**19 Buckingham Street**  
**London WC2N 6EF (GB)**

(54) **Plastic paint can**

(57) A paint can has a molded plastic bucket and cover which are releasably engageable with one another at a seal. The bucket (10) has an integrally-formed handle (46) with a cushioned grip formed therein. The handle (46) has an enlarged central portion (50) that facilitates knitting of the molten material fed into the handle mold. The cover (56) has a central panel (58) and a surrounding closure member (62) joined to the panel (58) by a connector (60). The connector (60) supports the central panel (58) intermediate the first sealing surface on the closure member. The connector (60) resiliently urges the closure member into sealing engagement with the bucket rim. The sealing surfaces have a polished finish. Grooves in a reinforcing ring on the bucket provide access for removal of the cover.

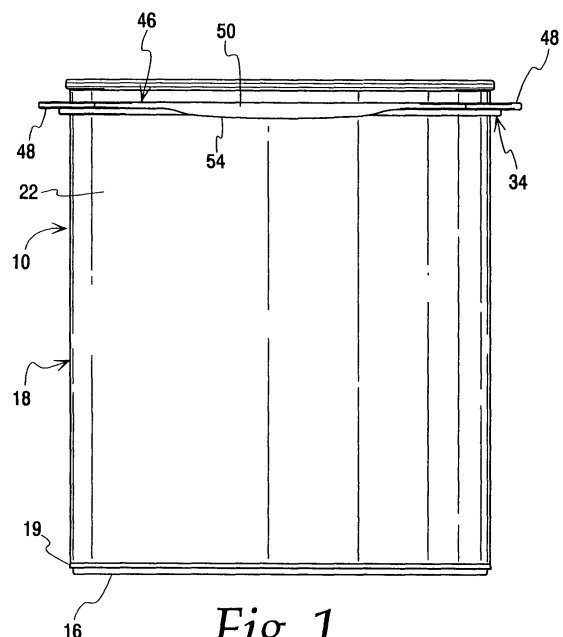

*Fig. 1*

**EP 1 717 061 A3**



**DOCUMENTS CONSIDERED TO BE RELEVANT**

Category	Citation of document with indication, where appropriate, of relevant passages	Relevant to claim	CLASSIFICATION OF THE APPLICATION (IPC)	
X	US 2004/055259 A1 (CARUSO NICHOLAS A) 25 March 2004 (2004-03-25) * paragraph [0025]; figure 1 *	1-8	INV. B44D3/12	
X	GB 2 199 311 A (* MARDON ILLINGWORTH LIMITED; * LAWSON MARDON) 6 July 1988 (1988-07-06) * page 2, line 11 - page 3, line 16; figures 1,2 *	1-8		
X	EP 0 186 979 A (MARDON ILLINGWORTH LIMITED) 9 July 1986 (1986-07-09) * page 3, line 28 - page 6, line 6; figures 1-3 *	1-8		
X	US 4 446 986 A (BOWEN ET AL) 8 May 1984 (1984-05-08) * column 3, line 4 - column 3, line 58; figures 1,3 *	1-8		
X	EP 0 112 691 A (MARDON ILLINGWORTH LIMITED) 4 July 1984 (1984-07-04) * column 3, line 6 - column 4, line 8; figures 1,2 *	1-8		TECHNICAL FIELDS SEARCHED (IPC)
X	GB 2 131 775 A (* MARDON ILLINGWORTH LIMITED) 27 June 1984 (1984-06-27) * page 1, line 90 - page 2, line 28; figures 1-5 *	1-8		B44D
A	EP 0 151 876 A (REED INTERNATIONAL P.L.C; CROWN BERGER EUROPE LIMITED) 21 August 1985 (1985-08-21) * page 8, line 13 - page 8, line 19; figure 1 *	1-8		
<del>The present search report has been drawn up for all claims</del>				
Place of search <b>Munich</b>		Date of completion of the search <b>7 September 2006</b>	Examiner <b>Sartor, Michele</b>	
CATEGORY OF CITED DOCUMENTS X : particularly relevant if taken alone Y : particularly relevant if combined with another document of the same category A : technological background O : non-written disclosure P : intermediate document		T : theory or principle underlying the invention E : earlier patent document, but published on, or after the filing date D : document cited in the application L : document cited for other reasons ..... & : member of the same patent family, corresponding document		

1  
EPO FORM 1503 03/82 (P04C01)

**CLAIMS INCURRING FEES**

The present European patent application comprised at the time of filing more than ten claims.

- Only part of the claims have been paid within the prescribed time limit. The present European search report has been drawn up for the first ten claims and for those claims for which claims fees have been paid, namely claim(s):
- No claims fees have been paid within the prescribed time limit. The present European search report has been drawn up for the first ten claims.

**LACK OF UNITY OF INVENTION**

The Search Division considers that the present European patent application does not comply with the requirements of unity of invention and relates to several inventions or groups of inventions, namely:

see sheet B

- All further search fees have been paid within the fixed time limit. The present European search report has been drawn up for all claims.
- As all searchable claims could be searched without effort justifying an additional fee, the Search Division did not invite payment of any additional fee.
- Only part of the further search fees have been paid within the fixed time limit. The present European search report has been drawn up for those parts of the European patent application which relate to the inventions in respect of which search fees have been paid, namely claims:
- None of the further search fees have been paid within the fixed time limit. The present European search report has been drawn up for those parts of the European patent application which relate to the invention first mentioned in the claims, namely claims:

1-8



The Search Division considers that the present European patent application does not comply with the requirements of unity of invention and relates to several inventions or groups of inventions, namely:

1. claims: 1-8

cover with closure member and connector locating member  
intermediate upper and lower boundaries of sealing surface  
---

2. claims: 9-10

cover with closure member and connector with lead-in leg  
---

3. claims: 11-19

paint can with cover and first sealing surface with height  
twice as second sealing surface  
---

4. claim: 20

paint can with cover and with sealing surfaces with polished  
finish  
---

5. claim: 21

paint can with cover and reinforcing ring  
---

**ANNEX TO THE EUROPEAN SEARCH REPORT  
ON EUROPEAN PATENT APPLICATION NO.**

EP 06 25 2251

This annex lists the patent family members relating to the patent documents cited in the above-mentioned European search report. The members are as contained in the European Patent Office EDP file on  
The European Patent Office is in no way liable for these particulars which are merely given for the purpose of information.

07-09-2006

Patent document cited in search report		Publication date	Patent family member(s)	Publication date
US 2004055259	A1	25-03-2004	NONE	
-----				
GB 2199311	A	06-07-1988	NONE	
-----				
EP 0186979	A	09-07-1986	AU 5120485 A	26-06-1986
			DK 563885 A	20-06-1986
			GB 2168960 A	02-07-1986
			JP 61152562 A	11-07-1986
			US 4606474 A	19-08-1986
-----				
US 4446986	A	08-05-1984	CA 1185927 A1	23-04-1985
			GB 2124602 A	22-02-1984
-----				
EP 0112691	A	04-07-1984	NONE	
-----				
GB 2131775	A	27-06-1984	NONE	
-----				
EP 0151876	A	21-08-1985	AU 575888 B2	11-08-1988
			AU 3661584 A	05-12-1985
			CA 1247560 A1	27-12-1988
			DE 3477754 D1	24-05-1989
			ES 291746 U	16-05-1986
			IE 55835 B1	30-01-1991
			US 4691838 A	08-09-1987
-----				

EPO FORM P0459

For more details about this annex : see Official Journal of the European Patent Office, No. 12/82