

[54] APPARATUS FOR CONTINUOUSLY SCOURING WEBS OF KNIT MATERIAL OR THE LIKE

1,803,968 5/1931 Heberlein.....68/205 R X
2,431,372 11/1947 Cook et al.....68/205 R
3,579,679 5/1971 Willis.....8/151

[72] Inventor: William J. Holm, Springfield, Vt.
[73] Assignee: Riggs & Lombard, Inc., Lowell, Mass.
[22] Filed: Dec. 2, 1969
[21] Appl. No.: 881,497

Primary Examiner—William I. Price
Attorney—Morse, Altman & Oates

[52] U.S. Cl.68/19.1, 68/18 C, 68/18 F, 68/205 R
[51] Int. Cl.B05c 3/132
[58] Field of Search.....68/19.1, 20, 18 R, 18 F, 18 C, 68/205 R; 8/151

[57] ABSTRACT

A running web of easily stretchable material such as knit goods or the like is solvent scoured on a continuous basis by means of a plurality of conveyor belts which deliver the web from a solvent spray station in an enclosure through a drying stage, the longitudinal tension in the fabric itself being employed to control the speed of the conveyors. The web is transferred from one conveyor to the next in a relaxed condition and in the drying stage steam coils are employed to heat the enclosed atmosphere whereby the vaporized solvent itself serves as a drying agent in flashing off liquid solvent in the web.

[56] References Cited

UNITED STATES PATENTS

1,527,369 2/1925 Meyer.....68/205 R

4 Claims, 1 Drawing Figure

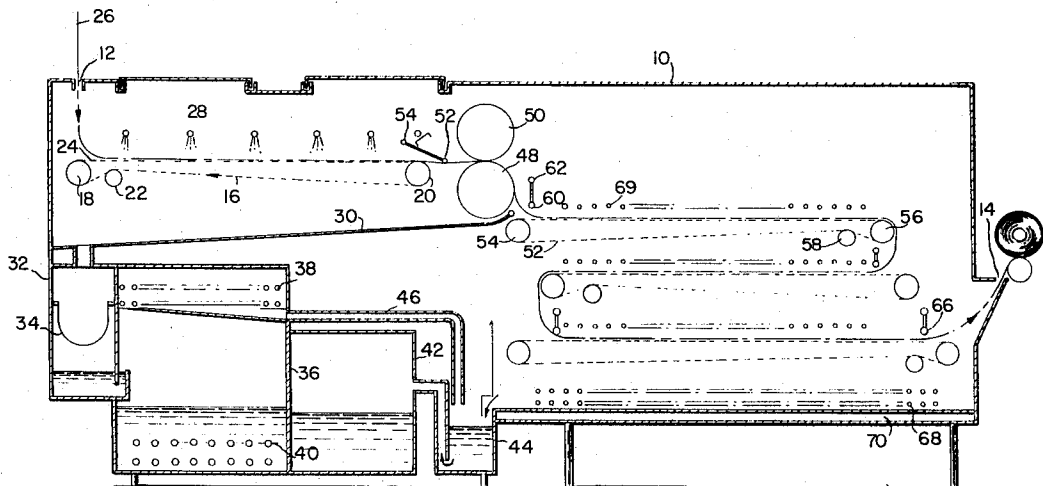

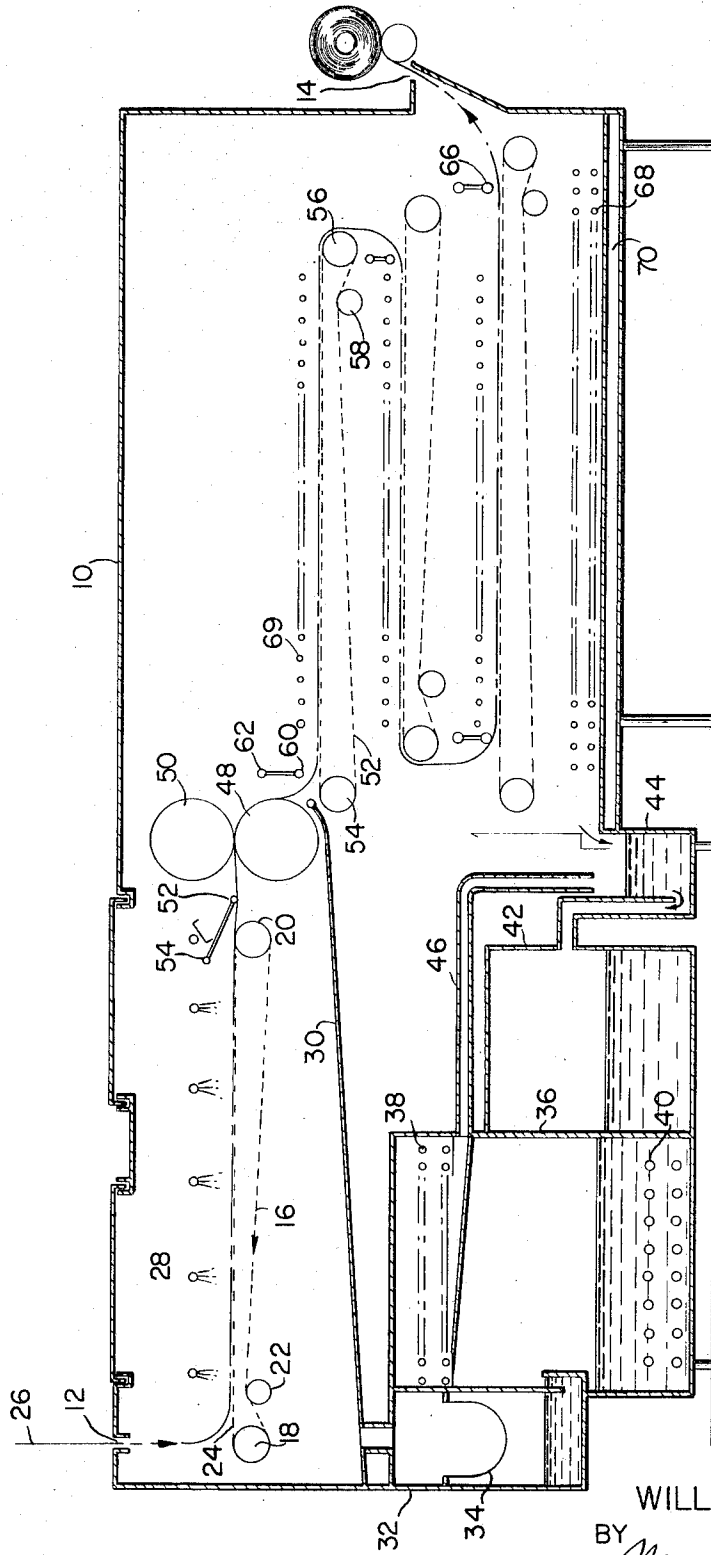

INVENTOR
WILLIAM J. HOLM
BY *Morse, Allman & Oates*
ATTORNEYS

APPARATUS FOR CONTINUOUSLY SCOURING WEBS OF KNIT MATERIAL OR THE LIKE

BACKGROUND OF THE INVENTION

1. Field of the Invention

This invention relates generally to the production of textile webs and more particularly is directed towards a novel method and associated apparatus for solvent scouring knit goods or the like on a continuous basis without distorting the fabric.

2. History of the Prior Art

In the production of textiles it is the practice to scour or otherwise treat the material to remove various impurities from the web. Because of the high stretch-stain ratio of knit materials and other fragile materials, there has been no satisfactory means available for processing materials of this type on a continuous basis. Heretofore, the practice has been to scour material of this type on a batch basis which is quite slow and inefficient.

Accordingly, it is an object of the present invention to provide a new method and associated apparatus for scouring or otherwise treating on a continuous basis fragile web materials such as knit goods or the like without distorting the web.

SUMMARY OF THE INVENTION

This invention features a novel method of processing a running web of knit material or the like on a continuous basis, comprising the steps of supporting the running web in an open width relaxed condition while spraying a solvent over the web. The web is then squeezed to remove excess solvent and transferred to another conveyor in an enclosure wherein the solvent is vaporized through the medium of a heated vapor atmosphere to dry the web.

This invention also features an apparatus for continuously scouring fragile fabric webs comprising a plurality of variable speed conveyors arranged to transfer the web from one to another in a relaxed condition and fully supported throughout and within an enclosure wherein the web is first washed with a solvent and then dried by a heated atmosphere employing heating elements disposed in proximity to the running web. A condensate system is provided for recovering the vaporized solvent.

BRIEF DESCRIPTION OF THE DRAWINGS

FIG. 1 is a sectional view in side elevation of an apparatus made according to the invention.

DETAILED DESCRIPTION OF THE PREFERRED EMBODIMENT

Referring now to the drawings, the reference character 10 generally indicates an enclosure in the form of a housing having an inlet slot 12 at the left-hand end thereof and an exit slot 14 at the right-hand end thereof. The apparatus is generally organized into three main sections namely, a wet out section in the upper left-hand portion thereof, a drying section in the right-hand portion thereof and a condensate section in the lower left-hand portion thereof.

The wet out section includes an endless conveyor belt 16 supported and driven by means of rolls 18 and 20 operating in conjunction with a tensioning roller 22. The belt and rollers are arranged to provide a horizontal upper reach 24, the left-hand end of which is located below the entrance slot 12 in position to pick up a web 26 delivered in open width form through the slot, downwardly onto the conveyor for movement to the right through the wet out section. Disposed transversely above the horizontal upper reach 24 of the conveyor and the web 26 are spaced spray nozzles 28 adapted to spray solvent or the like down over the web to wash out various impurities. In order to provide an optimum-washing action, it is desirable that a perforate conveyor belt 16 be employed to permit the solvent to flow through the web and belt. The solvent drains from the web and belt down onto an inclined baffle

30 which directs the solvent into a drain 32, preferably provided with a flock screen 34 for filtering the solvent before it drains through a solvent seal into a still 36. The still is provided with cooling coils 38 in its upper portion for condensing the vapor from solvent evaporated by heating coils 40 in its lower portion. Adjacent to the still 36 is a storage tank 42 for clean solvent, the tank connecting with a water separator 44 which also receives condensate draining from the cooling portion of the still by means of a drain line 46. In addition, the water separator also collects the condensate from the drying portion of the apparatus. Suitable pumps (not shown) are provided for delivering clean solvent from the storage tank to the spray nozzles 28.

As the web 26 leaves the conveyor 16 and before it enters into the bite of a pair of nip rollers 48 and 50, it engages a pivoted feeler 52 which senses the tension on the web and by means of a switch 54, which operates in response to the movement of the feeler 52, controls the speed of variable speed motors which drive either or both of the conveyor rollers 18 and 20. The arrangement insures that the web 26 does not become too slack or too tight and provides a direct and immediate control over the web tension by controlling the speed of the conveyor belt 16 independently of any other conveyor in the system.

From the nip rolls 48 and 50 the web 26 is delivered into the drying section of the apparatus and is guided down onto the uppermost of a bank of stacked conveyors, each comprised of a belt 52, rollers 54 and 56, at least one of which is driven, and a tensioning roller 58. The several conveyors are arranged in staggered relation with horizontal upper reaches positioned to receive the web as it travels from one conveyor downwardly to the next and thence out through the exit slot 14. At the start of each conveyor where the web is delivered onto the upper reach of the belt, a web feeler 60 is provided similar to the feeler 52 described above and each feeler is adapted to control a switch or other device by which variable speed motors driving each of the drying conveyors may be regulated independently of one another. The feelers 60 and 52 insure that the web does not become longitudinally stretched by controlling the speed of the conveyors and also insure that the web does not become too slack so as to fold or otherwise become distorted.

Disposed above the upper horizontal reach of each drying conveyor 52 are heating elements 64, typically steam coils, extending over the width of the web and coextensive therewith. The steam coils 64 serve to heat the atmosphere within the housing, the atmosphere being comprised primarily of vaporized solvent. The vaporized solvent is heated by the steam coils and the heated vapor itself is sufficient to cause the liquid solvent in the web to flash off into vapor, leaving the web free of the solvent so that by the time it is discharged from the tank the web is in a clean, dry condition.

A final tension feeler 66 is located at the discharge end of the lowermost conveyor prior to the exit slot 14 to control the speed of the takeup roll located outside the housing. Located at the base of the drying section are cooling coils 68 disposed directly above a water jacket 70 which is slightly inclined to deliver condensate into the water separator 44. In practice, the temperature of the atmosphere within the drying section can be maintained at a relatively low level and a range of 140°-160° F. is sufficient for most common types of scouring solvents to flash off into vapor.

It will be appreciated that the tension in the web itself controls the various conveyors individually to insure maintaining the web in a substantially relaxed condition as it is processed. While the apparatus has been described as employing pivoted sensing feelers, various other tension-sensing means may be employed, such as photoelectric systems for example, by which the sag in the material may be sensed and controlled by speeding up or slowing down individual conveyors.

Having thus described the invention what I claim and desire to obtain by Letters Patent of the United States is:

1. Apparatus for processing a web of knit material or the like with a liquid medium, comprising

3

- a. first conveyor means adapted to transport said web in a longitudinal direction fully supported and in an open width condition,
- b. liquid applying means associated with said first conveyor means for washing said web with said liquid while on said first conveyor means,
- c. second conveying means adapted to receive said web from said first conveying means for transporting said web in a longitudinal direction fully supported and in an open width condition,
- d. web squeezing means between said first and second conveying means for removing a substantial portion of the liquid from said web, and,
- e. atmosphere heating means associated with said second

4

conveyor means for heating the atmosphere adjacent that portion of said web on said second conveyor means sufficiently to vaporize the remaining liquid from said web.

5 2. Apparatus according to claim 1 wherein said conveyor means include continuous belts and rollers.

3. Apparatus according to claim 2 including independent variable speed drive means operatively connected to at least one of the rollers of each conveyor means.

10 4. Apparatus according to claim 3 including web tension-sensing means between said first and second conveyor means and operatively connected to said drive means for controlling the speed of said first conveyor means.

* * * * *

15

20

25

30

35

40

45

50

55

60

65

70

75