



- (51) International Patent Classification:  
A61B 6/00 (2006.01) A61N 5/10 (2006.01)
- (21) International Application Number:  
PCT/IB2013/050994
- (22) International Filing Date:  
7 February 2013 (07.02.2013)
- (25) Filing Language: English
- (26) Publication Language: English
- (30) Priority Data:  
61/601,088 21 February 2012 (21.02.2012) US
- (71) Applicant: **KONINKLIJKE PHILIPS N.V.** [NL/NL];  
High Tech Campus 5, NL-5656 AE Eindhoven (NL).
- (72) Inventors: **MANZKE, Robert**; c/o High Tech Campus  
Building 44, NL-5656 AE Eindhoven (NL). **SCHIRRA,  
Carsten Oliver**; c/o High Tech Campus Building 44, NL-  
5656 AE Eindhoven (NL).
- (74) Agents: **STEFFEN, Thomas** et al.; High Tech Campus,  
Building 44, NL-5656 AE Eindhoven (NL).
- (81) Designated States (unless otherwise indicated, for every  
kind of national protection available): AE, AG, AL, AM,

AO, AT, AU, AZ, BA, BB, BG, BH, BN, BR, BW, BY, BZ, CA, CH, CL, CN, CO, CR, CU, CZ, DE, DK, DM, DO, DZ, EC, EE, EG, ES, FI, GB, GD, GE, GH, GM, GT, HN, HR, HU, ID, IL, IN, IS, JP, KE, KG, KM, KN, KP, KR, KZ, LA, LC, LK, LR, LS, LT, LU, LY, MA, MD, ME, MG, MK, MN, MW, MX, MY, MZ, NA, NG, NI, NO, NZ, OM, PA, PE, PG, PH, PL, PT, QA, RO, RS, RU, RW, SC, SD, SE, SG, SK, SL, SM, ST, SV, SY, TH, TJ, TM, TN, TR, TT, TZ, UA, UG, US, UZ, VC, VN, ZA, ZM, ZW.

- (84) Designated States (unless otherwise indicated, for every kind of regional protection available): ARIPO (BW, GH, GM, KE, LR, LS, MW, MZ, NA, RW, SD, SL, SZ, TZ, UG, ZM, ZW), Eurasian (AM, AZ, BY, KG, KZ, RU, TJ, TM), European (AL, AT, BE, BG, CH, CY, CZ, DE, DK, EE, ES, FI, FR, GB, GR, HR, HU, IE, IS, IT, LT, LU, LV, MC, MK, MT, NL, NO, PL, PT, RO, RS, SE, SI, SK, SM, TR), OAPI (BF, BJ, CF, CG, CI, CM, GA, GN, GQ, GW, ML, MR, NE, SN, TD, TG).

**Declarations under Rule 4.17:**

- as to applicant's entitlement to apply for and be granted a patent (Rule 4.17(ii))

[Continued on next page]

(54) Title: ADAPTIVE RADIOTHERAPY WITH SPECTRAL TISSUE OF INTEREST IMAGING AND TRACKING

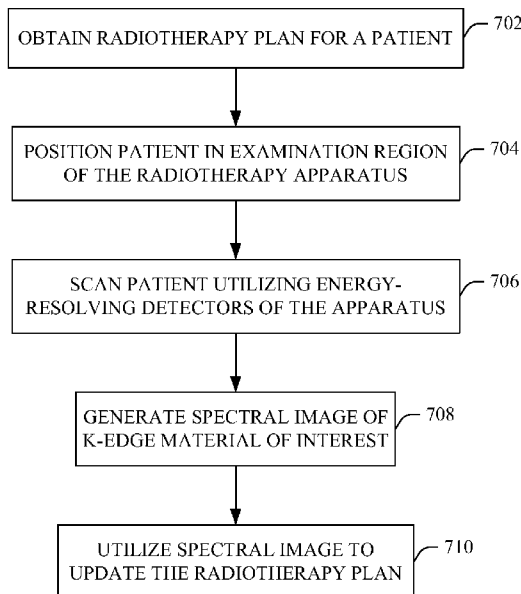

FIGURE 7

(57) Abstract: A radio therapy apparatus (100) includes a tissue of interest tracker (124) that receives a first image of tissue of interest and a second later acquired spectral image of the tissue of interest and tracks a change in a geometry and/or location of the tissue of interest based at least on the first and second images and generates a signal indicative of the change. The second image is generated based on a first spectral signal corresponding to an output of an energy-resolving radiation sensitive detector array for a first predetermined energy range and a second spectral signal corresponding to an output of the energy-resolving radiation sensitive detector array for a second predetermined energy range and visually enhances scanned structure corresponding to the first or second signals while visually suppressing scanned structure corresponding to the other of the first or second signals. An adaptive planner (126) updates a radiotherapy treatment plan based on the signal.





---

— *as to the applicant's entitlement to claim the priority of the earlier application (Rule 4.17(iii))* — *before the expiration of the time limit for amending the claims and to be republished in the event of receipt of amendments (Rule 48.2(h))*

**Published:**

— *with international search report (Art. 21(3))*

## ADAPTIVE RADIOTHERAPY WITH SPECTRAL TISSUE OF INTEREST IMAGING AND TRACKING

The following generally relates adaptive radiotherapy and more particularly to an adaptive radiotherapy with spectral tissue of interest imaging and tracking.

Radiotherapy (also referred to as radiation oncology and radiation therapy) is a technique in which ionizing radiation is used to control or kill tissue of interest, such as tumor cells, and works by damaging the DNA of the cells of the tissue of interest. With radiotherapy, the patient typically receives a dose of ionizing radiation administered regularly (e.g. daily) over a period of time, for example, on the order of several weeks. During a treatment session, the patient is positioned in an examination region of a radiotherapy device (generally referred to as a linear accelerator or a linac), which is used to irradiate the tumor. To spare surrounding tissue, the radiotherapy plan typically defines a beam shape and several angles of exposure that intersect at the tissue of interest, which results in an absorbed dose that is localized to the tissue of interest. A margin of tissue around the tissue of interest can be defined to allow for uncertainty in the treatment plan.

Over the course of the treatment sessions, a geometry (e.g., size and/or shape) of the tissue of interest and/or a location of the tissue of interest in the patient may change within the patient. This can occur due to shrinkage of the tissue of interest, patient weight loss, internal organ movement (e.g., respiration), etc. As a consequence, the radiotherapy plan may no longer optimize treatment of the tissue of interest or mitigate damage to surrounding tissue. This has been compensated for through tumor tracking and adaptive radiotherapy planning in which the relative geometry and/or location changes of the tissue of interest in the patient after the radiotherapy plan is created and before a treatment or subsequent treatment is tracked and used to update the radiotherapy plan for a treatment session. Such tracking has been achieved using bi-planar or CT-based kilovolt (kV) and/or megavolt (MV) imaging of gold beads implanted in or close proximity to the tissue of interest.

For tissue of interest tracking, the patient is scanned and the relative geometry and the location of the tissue of interest is determined with respect to the gold beads in the resulting images. The radiotherapy plan can then be updated based on this information and the initial plan so that the treatment beam again is substantially localized only at the tissue of interest.

Examples of such tracking are discussed in T. R. Mackie et al., "Tomotherapy: a new concept for the delivery of dynamic conformal radiotherapy," *MEDICAL PHYSICS-LANCASTER PA*, vol. 20, pp. 1709–1709, 1993, P. J. Keall et al., "The management of respiratory motion in radiation oncology report of AAPM Task Group 76," *Medical physics*, vol. 33, p. 3874, 5 2006, and R. D. Wiersma, W. Mao, and L. Xing, "Combined kV and MV imaging for real-time tracking of implanted fiducial markers," *Medical Physics*, vol. 35, no. 4, p. 1191, 2008.

Unfortunately, implanting such beads in or close to the tissue of interest in the patient is an invasive procedure and can be a challenging task. In view of at least the above, there is an unresolved need for one or more other approaches to tissue of interest tracking and 10 updating a radiotherapy plan based thereon in adaptive radiotherapy.

Aspects described herein address the above-referenced problems and others.

In one aspect, a radiotherapy apparatus includes a tissue of interest tracker that receives a first image of tissue of interest and a second later acquired spectral image of the tissue of interest and tracks a change in a geometry and/or location of the tissue of interest 15 based at least on the first and second images and generates a signal indicative of the change. The second later acquired spectral image is generated based on a first spectral signal corresponding to an output of an energy-resolving radiation sensitive detector array for a first predetermined energy range and a second spectral signal corresponding to an output of the energy-resolving radiation sensitive detector array for a second predetermined energy range. 20 The second later acquired spectral image visually enhances scanned structure corresponding to the first or second signals while visually suppressing scanned structure corresponding to the other of the first or second signals. An adaptive planner updates a radiotherapy treatment plan based on the signal indicative of the change from the tissue of interest tracker.

In another aspect, an imaging method for a radiotherapy system includes 25 receiving imaging data from an energy-resolving radiation sensitive detector array of the radiotherapy system, obtaining a predetermined sub-energy range of interest, which is a sub-energy range of the acquired data energy range, selecting sub-imaging of the received imaging data corresponding to the obtained sub-energy range of interest, and generating a spectral image based on the selected sub-imaging data.

30 In another aspect, a method includes obtaining a first image of tissue of interest, obtaining a second image of the tissue of interest, including a spectral composition of the tissue of interest, determining a changes in the tissue of interest between the first and second images, and updating a therapy plan based on the determined change to the tissue of interest.

The invention may take form in various components and arrangements of components, and in various steps and arrangements of steps. The drawings are only for purposes of illustrating the preferred embodiments and are not to be construed as limiting the invention.

5                   FIGURE 1 schematically illustrates a side view of an example radiotherapy system that includes energy-resolving radiation sensitive detectors.

                  FIGURE 2 schematically illustrates a front view looking into the example radiotherapy system of FIGURE 1 along line A-A.

10                   FIGURE 3 schematically illustrates an example scintillator / back mounted photosensor energy-resolving radiation sensitive detector.

                  FIGURE 4 schematically illustrates an example scintillator / side mounted photosensor energy-resolving radiation sensitive detector.

                  FIGURE 5 schematically illustrates direct conversion energy-resolving circuitry for a direct conversion detector of the example radiotherapy system of FIGURE 1.

15                   FIGURE 6 schematically illustrates an example comparator of the discriminator of the energy-resolving circuitry of FIGURE 5.

                  FIGURE 7 illustrates an example method.

                  The following describes an adaptive radiotherapy approach in which spectral x-ray and/or spectral CT imaging capabilities of a radiotherapy apparatus are configured to  
20                   image gold and/or other k-edge material doped nanoparticles (which are targeted to tissue of interest in a patient and optionally used enhance local dose to the cells of the tissue of interest during a radiotherapy session of the patient) to produce contrast enhanced spectral images of the tissue of interest. This may improve the contrast enhancement of the tissue of interest, relative to a configuration in which such spectral imaging capabilities are not present, which  
25                   allows for improved tissue of interest tracking and targeting in adaptive radiotherapy without interventional marker bead implantation in the patient.

                  FIGURES 1 and 2 schematically illustrate an example radiotherapy apparatus 100 that includes spectral imaging hardware and capabilities. FIGURE 1 schematically  
30                   illustrates a side view of the example radiotherapy apparatus 100, and FIGURE 2 schematically illustrates a front view looking into the example radiotherapy apparatus 100 along line A-A of FIGURE 1.

                  The illustrated radiotherapy apparatus 100 includes a generally stationary portion 102 and a rotatable portion 104, which is rotatably supported by the generally stationary portion 102 and rotates about an examination region 106. The rotatable portion

104 is configured to rotate over a predetermined angular range or arc, such as two hundred degrees, or more or less than two hundred degrees.

The radiotherapy apparatus 100 further includes a radiation source 108, such as a megavolt (MV) radiation source, which is supported by and rotates with the rotatable portion 104. In this example, the radiation source 108 is configured at least as a radiotherapy treatment source for radiotherapy apparatus 100. Optionally, the radiation source 108, in connection with an optional two-dimensional (e.g., a flap panel) detector array 110, is also configured as an imaging source. The radiation source 108, as shown, is located opposite the detector array 110, across the examination region 106. The source 108 and the detector array 110 form a source/detector pair 108/110.

The illustrated radiotherapy apparatus 100 also includes a radiation source 112, such as a kilovolt (kV) source. Likewise, the radiation source 112 is supported by and rotates with the rotatable portion 104 about the examination region 106. In this example, the source 112, in connection with a two-dimensional (e.g., a flat panel) detector array 114, is configured as an imaging source. Likewise, the radiation source 112, as shown, is located opposite the detector array 114, across the examination region 106. The source 112 and the detector array 114 form a source/detector pair 112/114.

In the illustrated embodiment, the source/detector pair 108/110 and the source/detector pair 112/114 are angularly offset from each other by approximately ninety degrees, as shown in FIGURE 2. However, in other embodiments, the angularly offset may be different. Furthermore, the illustrated source/detector pair 112/114 includes an x-ray source/detector pair. However, in another embodiment, the source/detector pair 112/114 alternatively or additionally includes a cone beam computed tomography (CT) source/detector pair.

Generally, for radiotherapy treatment, the source 108 emits a treatment beam, which is directed at and irradiates tissue of interest (e.g., a tumor or other tissue of interest) of a patient on a subject support 116, which is used to position the patient in the examination region 106 for treatment and/or imaging. The source 108 can be rotated to one or more predetermined angular locations and/or the subject support 116 can be moved to facilitate directing the treatment beam according to the radiotherapy plan and/or user changes thereto.

For imaging with the source 108/detector pair 110, the source 108 emits radiation, while at one or more static positions or while moving along the arc, that traverses the patient in the examination region 106, and the detector array 110 detects the radiation that traverses the patient in the examination region 106 and generates an image indicative thereof.

At a static position, the image is a two dimensional projection image. Projection images acquired at different angular positions can be used to produce a three dimensional image.

It is to be appreciated that treatment and imaging using the source 108 can be performed serially or concurrently.

5 For imaging with the source/detector pair 112/114, the source 112 emits radiation, while at one or more static positions or while moving along the arc, that traverses the patient in the examination region 106, and the detector array 114 detects the radiation that traverses the patient in the examination region 106 and generates an image indicative thereof.

At a static position, the image is a two dimensional projection image. Projection images  
10 acquired at different angular positions can be used to produce a three dimensional image.

In the illustrated embodiment, at least one of the detectors 110 or 114 includes energy-resolving detector pixels, including scintillator-based multi-spectral detectors and/or direct conversion detector pixels (e.g., Si, Ge, GaAs, CdTe, CdZnTe, etc.). FIGURES 3 and 4 respectively illustrate non-limiting examples of scintillator-based multi-spectral detectors  
15 and FIGURES 5 and 6 illustrate a non-limiting example of direction conversion detector photon counting circuitry.

Turning briefly to FIGURE 3, the energy-resolving detector 300 includes a first layer 302 of scintillation material and a second layer 304 of scintillation material. The first and second layers 302 and 304 are coupled such that the first layer 302 is on a side 306  
20 of the detector receiving incoming radiation. A photosensor 308 is coupled to a second opposing side of the detector 300 and includes photodiodes 310 and 312 facing the layers 302 and 304. Energy absorption, generally, is dependent on the thickness thereof. As such, in this example, lower energy photons are absorbed in the first layer 302 and higher energy photons are absorbed in the second layer 304.

25 The photodiodes 310 and 312 respectively have emission spectra that match the spectral sensitivities of the layers 302 and 304. As such, only the light emitted by the first layer 302 is absorbed by the photodiode 310, and only the light emitted by the second layer 304 is absorbed by the photodiode 312, and the photodiodes 310 and 311 respectively output signals indicative of radiation from different energy bands, which correspond to the first and  
30 second layers 302 and 304. FIGURE 4 shows a detector 400 in which the photosensor array 310 is coupled to a side 402 of the scintillator layers, which is perpendicular to the direction of incoming radiation. Other variations may include more scintillation layers / photosensors, and individual scintillation layers may have equal thickness (e.g., FIGURE 3) and/or different thickness (e.g., FIGURE 4).

FIGURES 5 and 6 schematically illustrate non-limiting circuitry 500 for processing an output signal of a direct conversion energy-resolving detector (and/or a conventional integrating scintillator/photosensor detector). Generally, the output of such a detector includes an electrical current or voltage signals having a peak amplitude that is indicative of the energy of a detected photon. A pulse shaper 502 processes the signal and generates a pulse such as voltage or other pulse indicative of the energy of the detected photon. It is to be appreciated that the detector signal may be amplified and/or otherwise processed before being processed by the pulse shaper 702.

An energy-discriminator 504 energy discriminates the pulse. In the illustrated example, the energy-discriminator 504 includes a comparator 506 that compares the amplitude of the pulse with two or more different energy thresholds, which correspond to different energies of interest. The comparator 506 produces an output signal indicative of the energy of the photon based on the comparison. This is shown in FIGURE 6, where the comparator 506 includes N sub-comparators  $602_1, \dots, 602_N$ , wherein N is an integer. Each of the sub-comparators  $606_1, \dots, 606_N$  includes a first input, which receives the output of the pulse shaper 502 and a second input, which receives a threshold value  $TH_1, \dots, TH_N$ , and the comparator 506 produces an output signal indicative of whether the amplitude of the incoming pulse exceeds the corresponding thresholds.

Returning to FIGURE 5, a counter 508 increments a count value for each threshold based on the output of the energy discriminator 506. For instance, when the output of the comparator 506 for a particular threshold indicates that the amplitude of the pulse exceeds the corresponding threshold, the count value for that threshold is incremented. A binner 510 energy bins the signals and, hence, the photons into two or more energy bins based on the counts. An energy bin generally encompass an energy sub-range or window. For example, a bin may be defined for the energy range between two thresholds, where a photon resulting in a count for the lower threshold but not for higher threshold would be assigned to that bin.

Returning to FIGURES 1 and 2, a general purpose computer serves as an operator console 118. The console 118 includes a human readable output device such as a monitor or display and an input device such as a keyboard and mouse. Software resident on the console 118 allows the operator to interact with the scanner 100 via a graphical user interface (GUI) or otherwise. A processor of the console 118 executes the software, which is stored in computer readable storage medium, such as physical memory, of the console 118.

Additionally or alternatively, some or all of the software can be stored on transitory medium such a carrier wave or signal.

An injector 120 is configured to inject a contrast material(s), for example, for a contrast enhanced imaging procedure. The illustrated injector 120 is controlled by the console 118. However, in an alternative embodiment, the contrast agent is manually administered, and the injector 120 can be omitted. A suitable contrast material includes target specific (e.g., a tumor) nanoparticles doped with gold, bismuth, gadolinium, etc. and/or other k-edge material. Nanoparticles doped with gold or other suitable material and targeted to specific cancer cells using dedicated antigens is discussed in R. Popovtzer et al., "Targeted Gold Nanoparticles enable Molecular CT Imaging of Cancer," *Nano letters*, vol. 8, no. 12, pp. 4593-4596, Dec. 2008.

Contrast materials with gold or other k-edge materials are discussed in D. P. Cormode et al., "Atherosclerotic Plaque Composition: Analysis with Multicolor CT and Targeted Gold Nanoparticles1," *Radiology*, vol. 256, no. 3, pp. 774 -782, 2010 and Pan, D. (2010). Computed Tomography in Color: NanoK-Enhanced Spectral CT Molecular imaging. *Angewandte Chemie*, 9635-9. Using such a contrast material along with the energy-resolving detectors (detectors 110 and/or 114) allows for tissue of interest tracking without implanted beads as the acquired data can be spectrally separated based on energy and images of the gold nanoparticles and, hence, substantially only the tissue of interest can be generated.

Moreover, gold doped nanoparticles may also allow for enhancing localized dose to the treated tumor, which may improve the efficacy of the radiotherapy treatment. Utilizing nanoparticles as such is discussed in R. I. Berbeco, W. Ngwa, and G. M. Makrigiorgos, "Localized Dose Enhancement to Tumor Blood Vessel Endothelial Cells via Megavoltage X-rays and Targeted Gold Nanoparticles: New Potential for External Beam Radiotherapy," *International Journal of Radiation Oncology\*Biophysics*, vol. 81, no. 1, pp. 270-276, Sep. 2011, and J. F. Hainfeld, F. A. Dilmanian, D. N. Slatkin, and H. M. Smilowitz, "Radiotherapy enhancement with gold nanoparticles," *Journal of Pharmacy and Pharmacology*, vol. 60, no. 8, pp. 977-985, 2008.

A spectral processor 122 processes the signals from the energy-resolving detectors 110 and/or 114. The spectral processor 122 can generate an image with data corresponding to one of the different energy ranges or two or more (including all) of the different energy ranges. For example, where one energy range corresponds to a k-edge of a k-edge material doped to a nanoparticle attached to the tissue of interest, the spectral processor

122 can process only the data corresponding to the radiation having energy in the energy range of the k-edge material, thereby producing a spectral image in which the tissue of interest is visually enhanced and other tissue is visually suppressed.

5 A tissue of interest (TOI) tracker 124 receives the spectral image of the tissue of interest (and/or other image) from the spectral processor 122 and tracks the geometry and/or location of the tissue of interest in the subject based at least on the spectral image of the tissue of interest and a previously acquired image. For example, the TOI tracker 124 may superimpose, combine, register, etc. the spectral image of the tissue of interest with the previous image, such as the initial planning image, an image after one or more treatments, an  
10 image before positioning the subject in the examination region 106, etc. The TOI tracker 124 visually presents the resulting data in a graphical user interface (GUI).

The TOI tracker 124 can, automatically without user interaction or with user interaction, determine any change in geometry and/or location of the tissue of interest. The TOI tracker 124 can generate a signal indicative of any change. The signal may include  
15 numerical values, a visual representation (e.g., displayed in the GUI), and/or other information. This can be performed for real-time and/or inter-fractional tracking. Known and/or other automatic and/or user interaction based segmentation approaches can be used to identify the geometry and/or location in the images, and known and/or other automatic and/or user interaction based measurement tools can be used to measure any change in geometry  
20 and/or location.

An adaptive planner 126 updates, automatically and/or with user interaction, the treatment plan based on the signal from the TIO tracker 124. The update may include updating the position of the treatment source 108 and/or the subject support 116 to re-focus the treatment beam so that the treatment beam once again is substantially localized only at  
25 the tissue of interest. With user interaction updates, the adaptive planner 126 visually presents a proposed recommended update via a GUI, and the user accepts, modifies or rejects the update.

The updated plan is provided to the console 118, which uses the plan to position the treatment source 108 and/or the subject support 116. Alternatively, the user uses  
30 the update plan to position the treatment source 108 and/or the subject support 116. The treatment plan can be created based on images acquired by the system 100 and/or other system such as a CT scanner, a magnetic resonance (MR) scanner, positron emission tomography (PET), etc.

Variations are contemplated.

In the illustrated embodiment, the radiotherapy apparatus 100 includes a single x-ray or CT source 112. In another embodiment, the radiotherapy apparatus 100 includes two or more sources 112 and corresponding detectors 114, arranged at different angular locations with respect to each other in the x/y plane, where at least two of the radiation sources 112 emit radiation with different energy spectra. The at least two of the two or more radiation sources can be concurrently or individually employed during a same scan and different scans.

Additionally or alternatively, at least one of the sources 110 or 112 is configured to switch between two or more emission voltages, for example, the source 112 can be configured to switch between 20 kVp to 140 kVp and/or other combination of kVps. A source controller or the like can switch the radiation source voltage from scan to scan, integration period to integration period, within an integration period, and/or otherwise. As a result, radiation beams having different mean emission energy spectra can be generated.

In another embodiment, one or more of the detector 110 or the source/detector pair 112/114 are omitted from the radiotherapy apparatus 110. Where either or both are omitted, a spectral imaging scanner separate from the radiotherapy apparatus 100 can be used for spectral imaging.

FIGURE 7 illustrate an example method.

It is to be appreciated that the ordering of the acts in the methods described herein is not limiting. As such, other orderings are contemplated herein. In addition, one or more acts may be omitted and/or one or more additional acts may be included.

At 702, a radiotherapy plan is obtained for a patient. This plan can be created using known and/or other approaches.

At 704, a patient is positioned in the examination region 106 of the radiotherapy apparatus 100.

At 706, the patient is scanned using at least one of the source/detector pairs 108/110 or 112/114.

At 708, the acquired data is processed to produce a spectral image of a k-edge material of a nanoparticle attached to tissue of interest of the patient, wherein the spectral image visually enhances the k-edge material in the spectral image while visually suppressing other material in the spectral image.

At 710, the spectral image is used to update the radiotherapy plan, including updating parameters that are based on the geometry and/or location of the tissue of interest in the patient, as described herein.

For example, the spectral image can be compared with a previously acquired image, and a geometry and/or location change in the tissue of interest, as determined between the two images, can be used to update the therapy plan.

5 It is to be appreciated that the updated radiotherapy plan can be used when employing the radiotherapy apparatus 100 to treat the tissue of interest. Furthermore, the nanoparticles may facilitate localizing dose enhancement to the tissue of interest during treatment of the tissue of interest using the radiotherapy apparatus 100.

10 At least a portion of the above may be implemented by way of computer readable instructions, encoded or embedded on computer readable storage medium, which, when executed by a computer processor(s), cause the processor(s) to carry out the described acts. Additionally or alternatively, at least one of the computer readable instructions is carried by a signal, carrier wave or other transitory medium.

15 The invention has been described with reference to the preferred embodiments. Modifications and alterations may occur to others upon reading and understanding the preceding detailed description. It is intended that the invention be constructed as including all such modifications and alterations insofar as they come within the scope of the appended claims or the equivalents thereof.

## CLAIMS:

1. A radiotherapy apparatus (100), comprising:

a tissue of interest tracker (124) that receives a first image of tissue of interest and a second later acquired spectral image of the tissue of interest and tracks a change in a geometry and/or location of the tissue of interest based at least on the first and second images and generates a signal indicative of the change,

5 wherein the second later acquired spectral image is generated based on a first spectral signal corresponding to an output of an energy-resolving radiation sensitive detector array of the radiotherapy apparatus for a first predetermined energy range and a second spectral signal corresponding to an output of the energy-resolving radiation sensitive detector array of the radiotherapy apparatus for a second predetermined energy range,

10 wherein the second later acquired spectral image visually enhances scanned structure corresponding to the first or second signals while visually suppressing scanned structure corresponding to the other of the first or second signals; and

an adaptive planner (126) that updates a radiotherapy treatment plan based on the signal indicative of the change from the tissue of interest tracker.

2. The radiotherapy apparatus of claim 2, wherein the tissue of interest tracker visually presents a superposition of the first and the second images, including indicia corresponding to the change in the geometry and/or the location of the tissue of interest.

3. The radiotherapy apparatus of any of claims 1 to 3, wherein adaptive planner visually presents a recommended update and updates the radiotherapy treatment plan with the update in response to receiving a signal indicative of user confirmation of the update.

4. The radiotherapy apparatus of any of claims 1 to 3, wherein the update includes updating at least one of a position of a treatment source 108 or a position of a subject support to re-focus a treatment beam so that the treatment beam is substantially localized only at the tissue of interest.

5. The radiotherapy apparatus of any of claims 1 to 4, further comprising:  
at least one radiation source (108, 112) that emits ionizing radiation that traverses an examination region (106); and  
at least one energy-resolving radiation sensitive detector array (110, 114) that detects ionizing radiation that traverses the examination region and generates the first and second spectral signals.
6. The radiotherapy apparatus of claim 5, wherein the at least one radiation source is a megavolt source.
7. The radiotherapy apparatus of claim 5, wherein the at least one radiation source is a kilovolt source.
8. The radiotherapy apparatus of claim 5, wherein the at least one radiation source includes a megavolt radiation source and a kilovolt radiation source.
9. The radiotherapy apparatus of any of claims 5 to 7, wherein the detector array includes at least one scintillator/photodiode pair (300, 400) based detector having a spectral sensitivity corresponding only to the first or second energy range.
10. The radiotherapy apparatus of any of claims 5 to 7, wherein the detector array includes at least one direct conversion photon counting detector and corresponding energy resolving circuitry (500).
11. The radiotherapy apparatus of any of claims 1 to 10, wherein at least one of the first or second energy ranges corresponds to a k-edge energy of interest.
12. The radiotherapy apparatus of claim 11, wherein the k-edge energy of interest corresponds to a k-edge energy of nanoparticles bound to tissue of interest of a patient.
13. The radiotherapy apparatus of any of claims 1 to 12, further comprising:  
a console (118) that controls an injector (120) administering the contrast material.

14. The radiotherapy apparatus of any of claims 1 to 13, further comprising:  
a treatment source (110), wherein the spectral image is used to determine at least one operating parameter of the treatment source.
15. An imaging method for a radiotherapy system (100), comprising:  
receiving imaging data from an energy-resolving radiation sensitive detector array (110, 112) of the radiotherapy system;  
obtaining a predetermined sub-energy range of interest, which is a sub-energy range of the acquired data energy range;  
selecting sub-imaging of the received imaging data corresponding to the obtained sub-energy range of interest; and  
generating a spectral image based on the selected sub-imaging data.
16. The imaging method of claim 15, further comprising:  
utilizing the spectral image to track a change in a geometry and/or a location of tissue of interest for a radiotherapy session.
17. The imaging method of claim 16, further comprising:  
tracking the change by determining in a geometry and/or a location of tissue of interest between the spectral image and a previously acquired image of the tissue of interest.
18. The imaging method of claim 17, further comprising:  
combining the spectral image and the previously acquired image, generating a combined image; and  
visually presenting the combined image.
19. The imaging method of any of claims 15 to 18, wherein the sub-energy range of interest corresponds to a k-edge energy of interest.
20. The imaging method of claim 19, wherein the k-edge energy of interest corresponds to a k-edge energy of nanoparticles bound to tissue of interest of a patient.
21. The imaging method of any of claims 15 to 20, further comprising:  
using the spectral image to determine at least one operating parameter of a

treatment source (110) of the radiotherapy system.

22. A method, comprising:
- obtaining a first image of tissue of interest;
  - obtaining a second image of the tissue of interest, including a spectral composition the of tissue of interest;
  - determining a changes in the tissue of interest between the first and second images; and
  - updating a therapy plan based on the determined change to the tissue of interest.

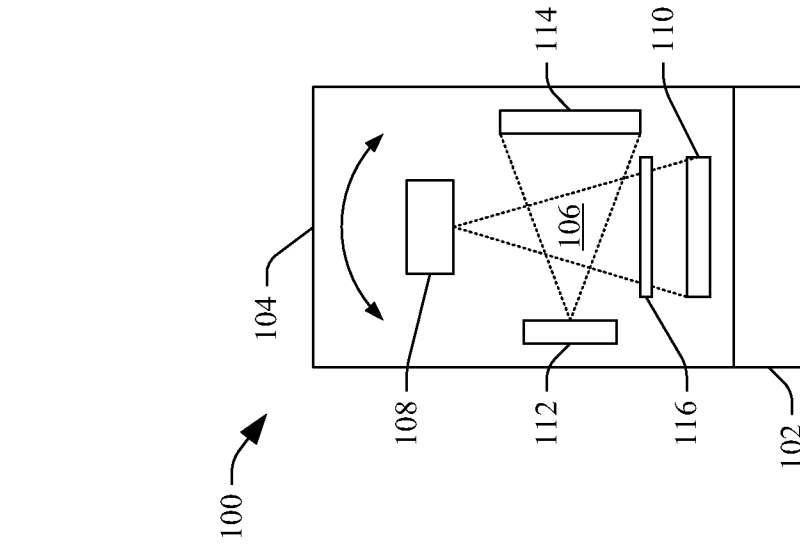

FIGURE 1

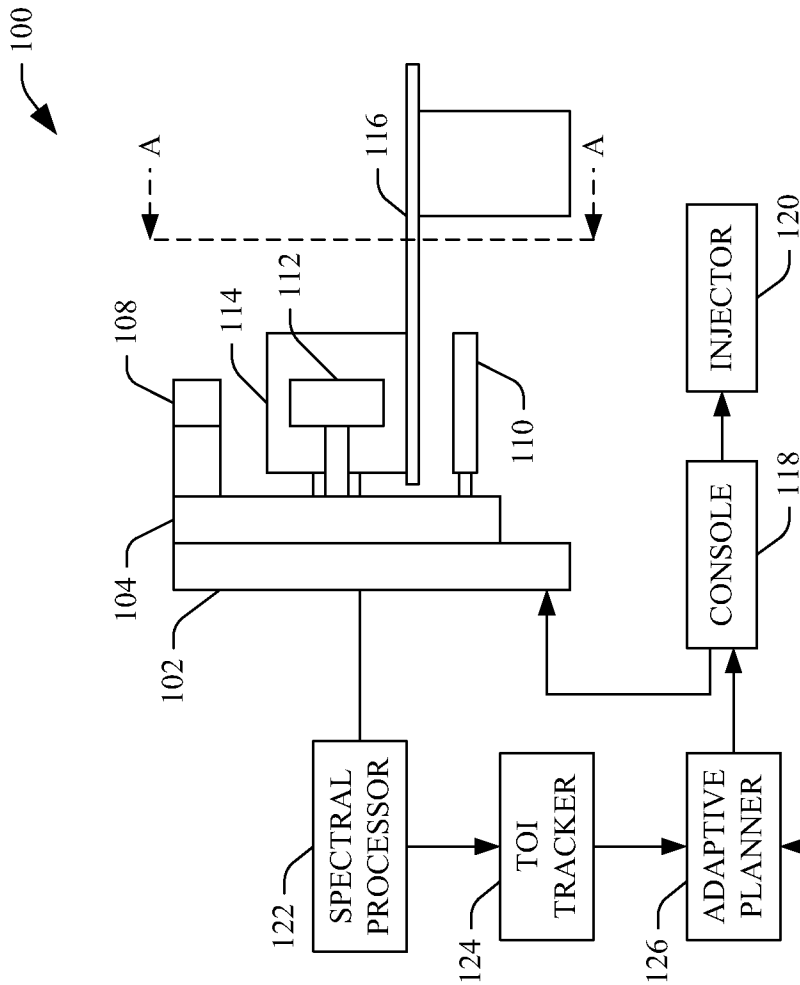

FIGURE 2

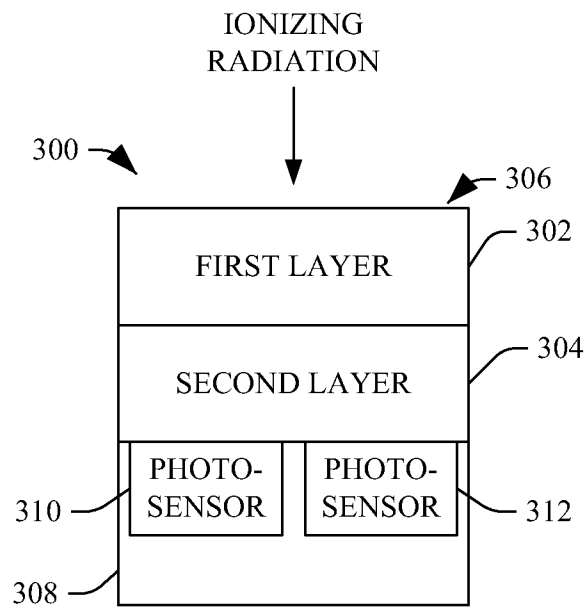

FIGURE 3

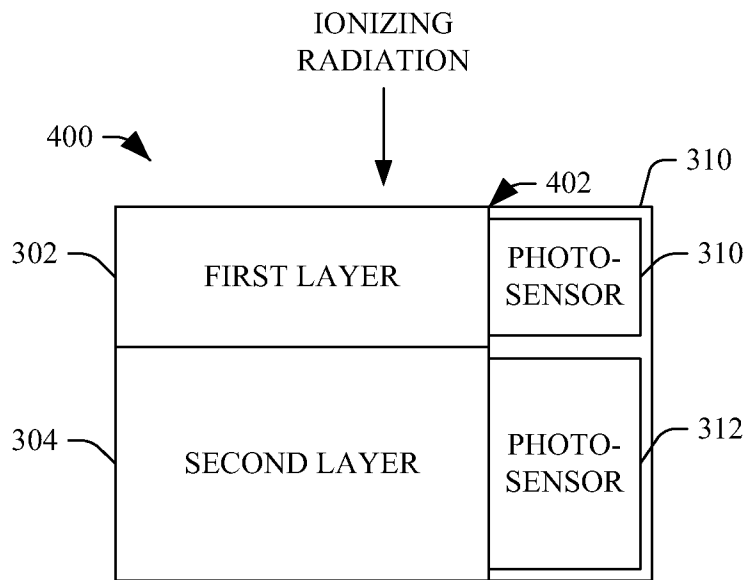

FIGURE 4

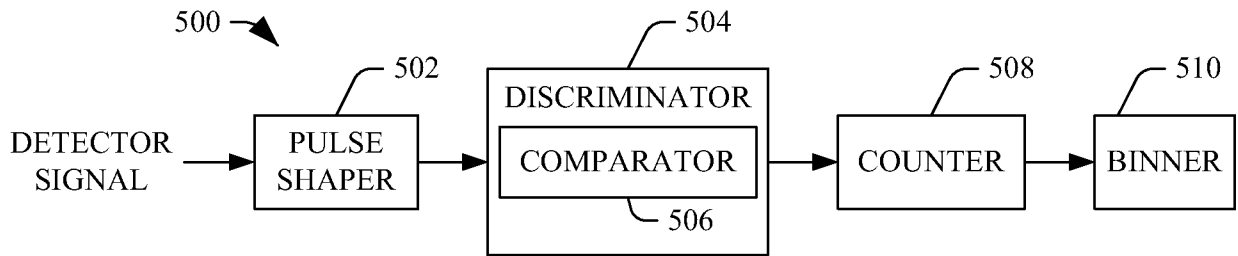

FIGURE 5

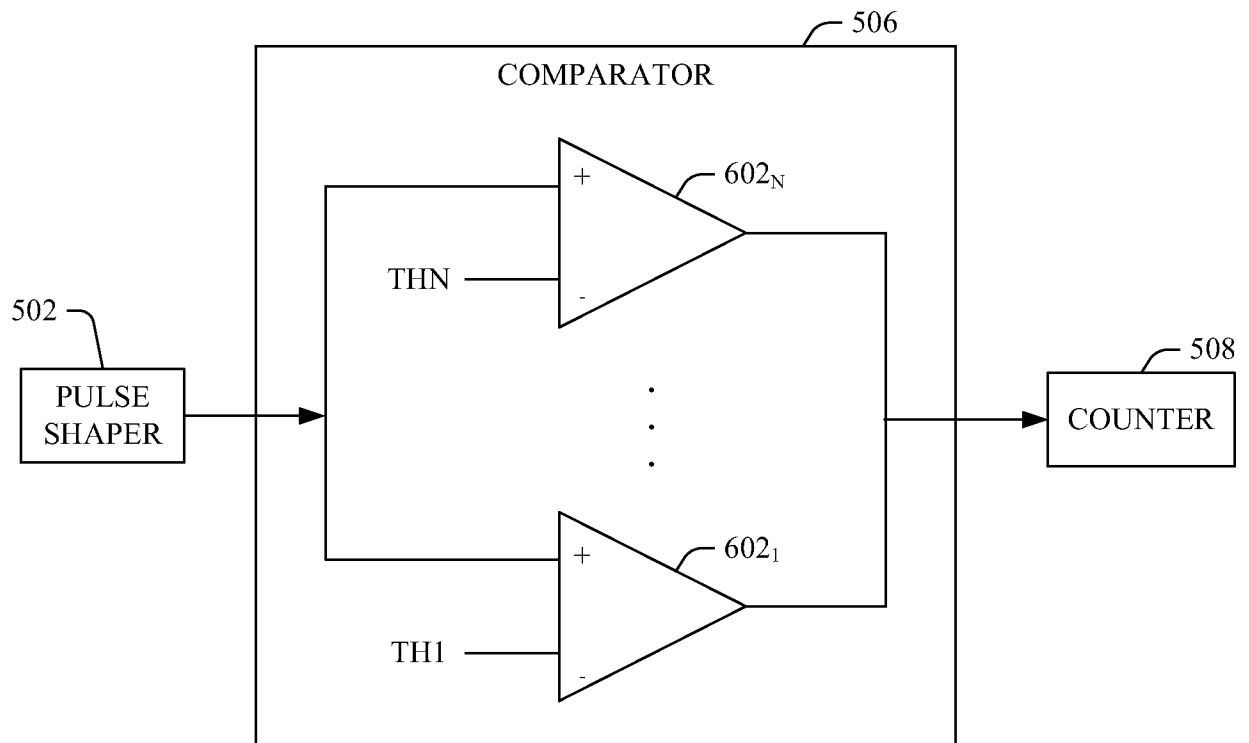

FIGURE 6

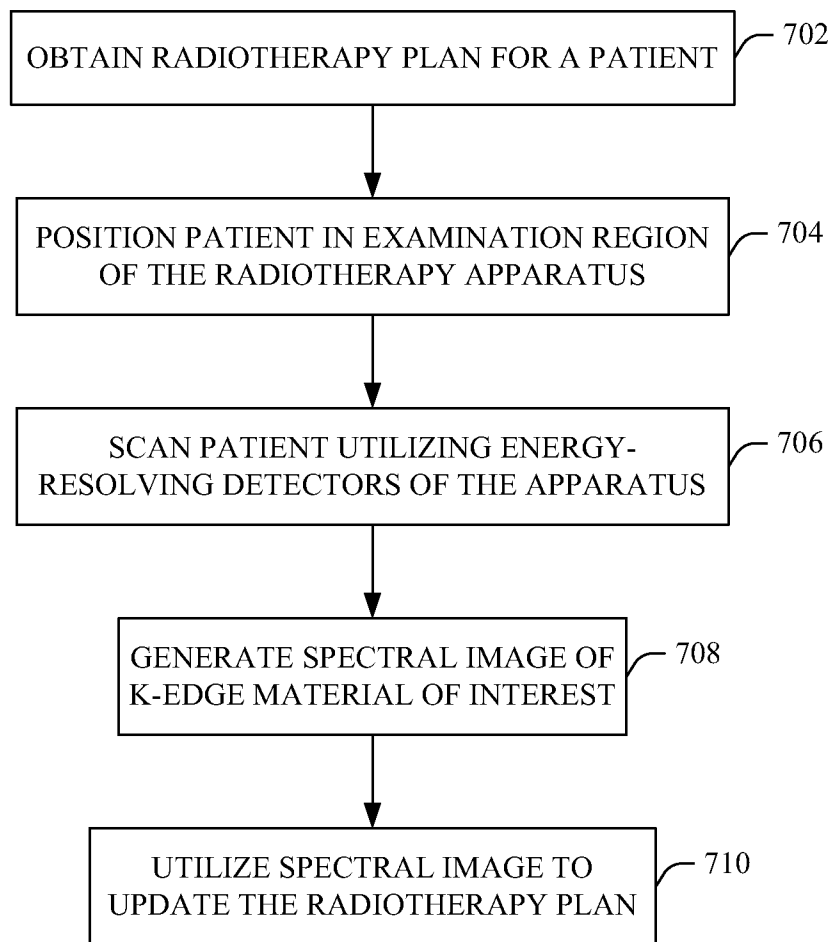

FIGURE 7

# INTERNATIONAL SEARCH REPORT

International application No <b>PCT/IB2013/050994</b>
--

<b>A. CLASSIFICATION OF SUBJECT MATTER</b> INV. A61B6/00                      A61N5/10 ADD.		
According to International Patent Classification (IPC) or to both national classification and IPC		
<b>B. FIELDS SEARCHED</b>		
Minimum documentation searched (classification system followed by classification symbols) A61B A61N		
Documentation searched other than minimum documentation to the extent that such documents are included in the fields searched		
Electronic data base consulted during the international search (name of data base and, where practicable, search terms used)  EPO-Internal, WPI Data		
<b>C. DOCUMENTS CONSIDERED TO BE RELEVANT</b>		
Category*	Citation of document, with indication, where appropriate, of the relevant passages	Relevant to claim No.
X	US 2010/316259 A1 (LIU WU [US] ET AL) 16 December 2010 (2010-12-16) abstract; figure 2 paragraphs [0013] - [0015], [0023], [0024], [0035], [0038], [0041] -----	1-14
X	MACKIE T R ET AL: "TOMOTHERAPY: A NEW CONCEPT FOR THE DELIVERY OF DYNAMIC CONFORMAL RADIOTHERAPY", MEDICAL PHYSICS, AIP, MELVILLE, NY, US, vol. 20, no. 6, 1 November 1993 (1993-11-01), pages 1709-1719, XP000422132, ISSN: 0094-2405, DOI: 10.1118/1.596958 ISBN: 978-1-930524-56-9 abstract; figure 1A paragraph bridging pages 1710 and 1711 -----  -/--	1
<input checked="" type="checkbox"/> Further documents are listed in the continuation of Box C. <input checked="" type="checkbox"/> See patent family annex.		
* Special categories of cited documents :		
"A" document defining the general state of the art which is not considered to be of particular relevance  "E" earlier application or patent but published on or after the international filing date  "L" document which may throw doubts on priority claim(s) or which is cited to establish the publication date of another citation or other special reason (as specified)  "O" document referring to an oral disclosure, use, exhibition or other means  "P" document published prior to the international filing date but later than the priority date claimed	"T" later document published after the international filing date or priority date and not in conflict with the application but cited to understand the principle or theory underlying the invention  "X" document of particular relevance; the claimed invention cannot be considered novel or cannot be considered to involve an inventive step when the document is taken alone  "Y" document of particular relevance; the claimed invention cannot be considered to involve an inventive step when the document is combined with one or more other such documents, such combination being obvious to a person skilled in the art  "&" document member of the same patent family	
Date of the actual completion of the international search	Date of mailing of the international search report	
6 June 2013	18/06/2013	
Name and mailing address of the ISA/ European Patent Office, P.B. 5818 Patentlaan 2 NL - 2280 HV Rijswijk Tel. (+31-70) 340-2040, Fax: (+31-70) 340-3016	Authorized officer  Kajzar, Anna	

**INTERNATIONAL SEARCH REPORT**

International application No PCT/IB2013/050994
---

C(Continuation). DOCUMENTS CONSIDERED TO BE RELEVANT

Category*	Citation of document, with indication, where appropriate, of the relevant passages	Relevant to claim No.
A	D. P. CORMODE ET AL: "Atherosclerotic Plaque Composition: Analysis with Multicolor CT and Targeted Gold Nanoparticles", RADIOLOGY, vol. 256, no. 3, 1 September 2010 (2010-09-01), pages 774-782, XP055021807, ISSN: 0033-8419, DOI: 10.1148/radiol.10092473 abstract; figure 1 page 781, left-hand column -----	11-13
A	US 2012/039519 A1 (FEI BAOWEI [US] ET AL) 16 February 2012 (2012-02-16) abstract; figures 1-4 paragraphs [0014], [0031] - [0033]; claims 1,7 -----	1-14

# INTERNATIONAL SEARCH REPORT

International application No.  
PCT/IB2013/050994

## Box No. II Observations where certain claims were found unsearchable (Continuation of item 2 of first sheet)

This international search report has not been established in respect of certain claims under Article 17(2)(a) for the following reasons:

1.  Claims Nos.: 15-22  
because they relate to subject matter not required to be searched by this Authority, namely:  
Rule 39.1(iv) PCT - Method for treatment of the human or animal body by therapy
2.  Claims Nos.:  
because they relate to parts of the international application that do not comply with the prescribed requirements to such an extent that no meaningful international search can be carried out, specifically:
3.  Claims Nos.:  
because they are dependent claims and are not drafted in accordance with the second and third sentences of Rule 6.4(a).

## Box No. III Observations where unity of invention is lacking (Continuation of item 3 of first sheet)

This International Searching Authority found multiple inventions in this international application, as follows:

1.  As all required additional search fees were timely paid by the applicant, this international search report covers all searchable claims.
2.  As all searchable claims could be searched without effort justifying an additional fees, this Authority did not invite payment of additional fees.
3.  As only some of the required additional search fees were timely paid by the applicant, this international search report covers only those claims for which fees were paid, specifically claims Nos.:
4.  No required additional search fees were timely paid by the applicant. Consequently, this international search report is restricted to the invention first mentioned in the claims; it is covered by claims Nos.:

### Remark on Protest

- The additional search fees were accompanied by the applicant's protest and, where applicable, the payment of a protest fee.
- The additional search fees were accompanied by the applicant's protest but the applicable protest fee was not paid within the time limit specified in the invitation.
- No protest accompanied the payment of additional search fees.

# INTERNATIONAL SEARCH REPORT

Information on patent family members

International application No  
PCT/IB2013/050994

Patent document cited in search report	Publication date	Patent family member(s)	Publication date
US 2010316259	A1	16-12-2010	NONE
-----			
US 2012039519	A1	16-02-2012	NONE
-----			