



(86) Date de dépôt PCT/PCT Filing Date: 2012/11/08  
(87) Date publication PCT/PCT Publication Date: 2013/05/16  
(85) Entrée phase nationale/National Entry: 2014/04/17  
(86) N° demande PCT/PCT Application No.: NO 2012/050218  
(87) N° publication PCT/PCT Publication No.: 2013/070086  
(30) Priorité/Priority: 2011/11/08 (NO20111531)

(51) Cl.Int./Int.Cl. *A41D 31/00* (2006.01),  
*A41D 27/28* (2006.01)  
(71) Demandeur/Applicant:  
HELLY HANSEN AS, NO  
(72) Inventeurs/Inventors:  
ULRIKSEN, KRISTOFFER, NO;  
JENSSEN, TOR, NO;  
OYGARDEN, SILJE, NO  
(74) Agent: KIRBY EADES GALE BAKER

(54) Titre : VETEMENT A COUCHES MULTIPLES  
(54) Title: MULTI-LAYERED GARMENT

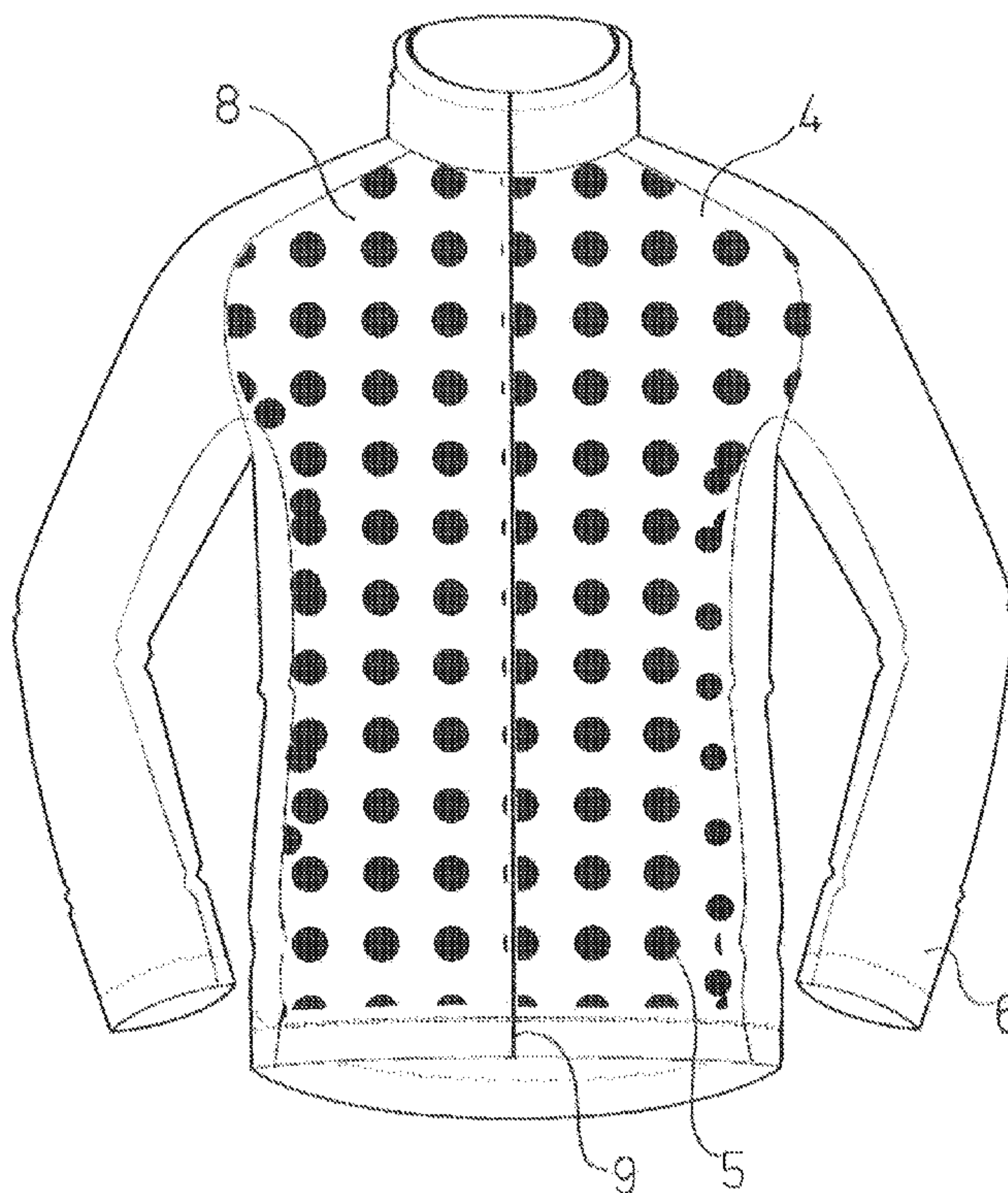

Fig. 8a

(57) **Abrégé/Abstract:**

A garment comprising at least two layers, wherein the first layer (1) is a protective shell, the second layer (4) is an insulating layer. The insulating layer (4) has a thickness sufficient to form predefined holes each capable of holding a volume of air.



(12) INTERNATIONAL APPLICATION PUBLISHED UNDER THE PATENT COOPERATION TREATY (PCT)

(19) World Intellectual Property  
Organization  
International Bureau(10) International Publication Number  
**WO 2013/070086 A1**(43) International Publication Date  
16 May 2013 (16.05.2013)

- (51) International Patent Classification:  
*A41D 31/00* (2006.01)    *A41D 27/28* (2006.01)
- (21) International Application Number:  
PCT/NO2012/050218
- (22) International Filing Date:  
8 November 2012 (08.11.2012)
- (25) Filing Language: English
- (26) Publication Language: English
- (30) Priority Data:  
20111531    8 November 2011 (08.11.2011)    NO
- (71) Applicant: HELLY HANSEN AS [NO/NO]; Munke-  
damsveien 35, N-0250 Oslo (NO).
- (72) Inventors: ULRIKSEN, Kristoffer; Kordahlveien 30, N-  
1591 Sperrebotn (NO). JENSSEN, Tor; Øvre Smestad vei  
5, N-0378 Oslo (NO). ØYGARDEN, Silje; Jens Bjelkes  
gate 16A, N-0562 Oslo (NO).
- (74) Agent: OSLO PATENTKONTOR AS; Postboks 7007  
M, N-0306 Oslo (NO).
- (81) Designated States (*unless otherwise indicated, for every  
kind of national protection available*): AE, AG, AL, AM,  
AO, AT, AU, AZ, BA, BB, BG, BH, BN, BR, BW, BY,  
BZ, CA, CH, CL, CN, CO, CR, CU, CZ, DE, DK, DM,  
DO, DZ, EC, EE, EG, ES, FI, GB, GD, GE, GH, GM, GT,  
HN, HR, HU, ID, IL, IN, IS, JP, KE, KG, KM, KN, KP,  
KR, KZ, LA, LC, LK, LR, LS, LT, LU, LY, MA, MD,  
ME, MG, MK, MN, MW, MX, MY, MZ, NA, NG, NI,  
NO, NZ, OM, PA, PE, PG, PH, PL, PT, QA, RO, RS, RU,  
RW, SC, SD, SE, SG, SK, SL, SM, ST, SV, SY, TH, TJ,  
TM, TN, TR, TT, TZ, UA, UG, US, UZ, VC, VN, ZA,  
ZM, ZW.
- (84) Designated States (*unless otherwise indicated, for every  
kind of regional protection available*): ARIPO (BW, GH,  
GM, KE, LR, LS, MW, MZ, NA, RW, SD, SL, SZ, TZ,  
UG, ZM, ZW), Eurasian (AM, AZ, BY, KG, KZ, RU, TJ,  
TM), European (AL, AT, BE, BG, CH, CY, CZ, DE, DK,  
EE, ES, FI, FR, GB, GR, HR, HU, IE, IS, IT, LT, LU, LV,

[Continued on next page]

(54) Title: MULTI-LAYERED GARMENT

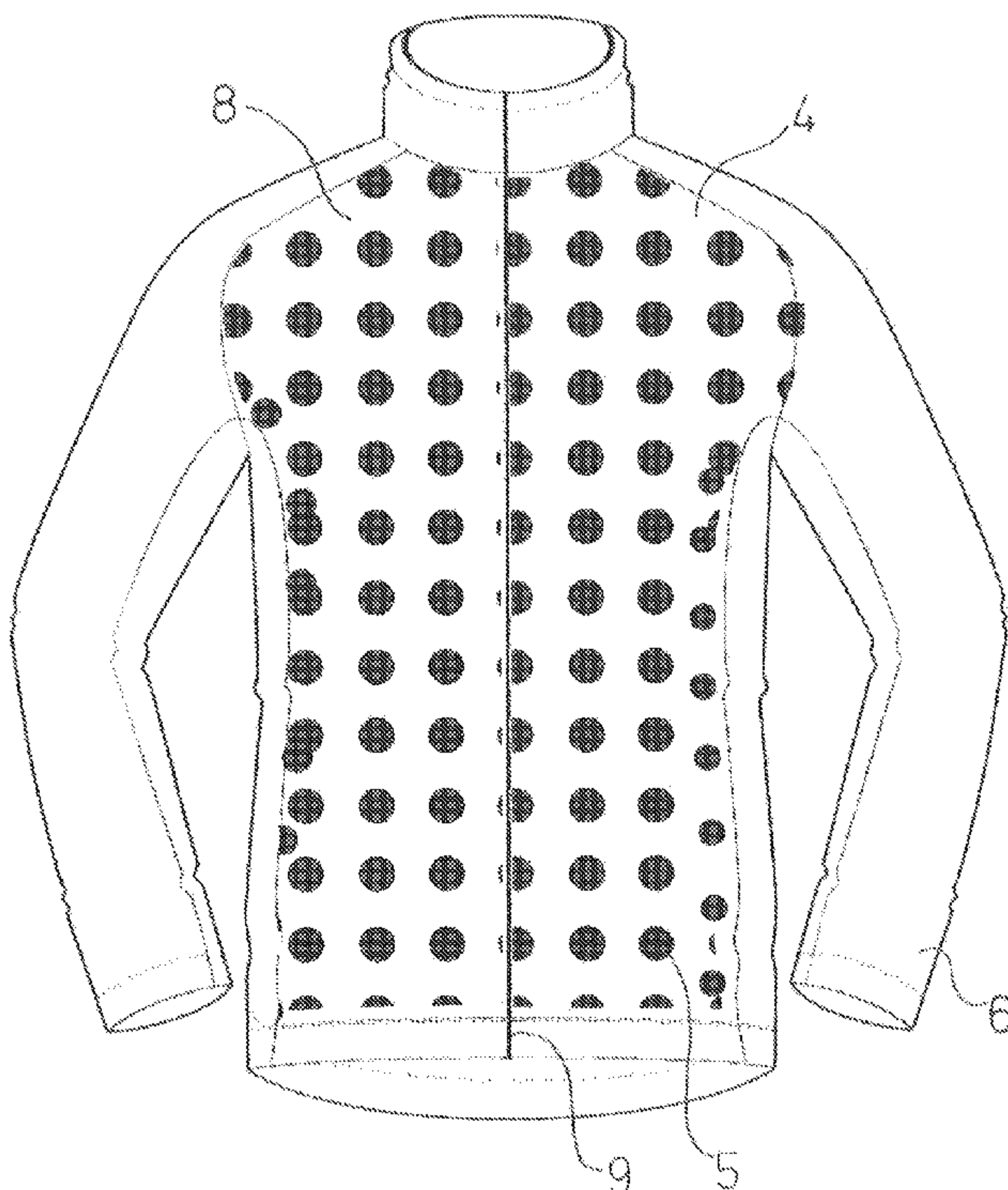

Fig. 8a

(57) Abstract: A garment comprising at least two layers, wherein the first layer (1) is a protective shell, the second layer (4) is an insulating layer. The insulating layer (4) has a thickness sufficient to form predefined holes each capable of holding a volume of air.

**WO 2013/070086 A1** 

---

MC, MK, MT, NL, NO, PL, PT, RO, RS, SE, SI, SK,  
SM, TR), OAPI (BF, BJ, CF, CG, CI, CM, GA, GN, GQ,  
GW, ML, MR, NE, SN, TD, TG).

— *before the expiration of the time limit for amending the  
claims and to be republished in the event of receipt of  
amendments (Rule 48.2(h))*

**Published:**

— *with international search report (Art. 21(3))*

**MULTI-LAYERED GARMENT**

The present invention relates to garments, more specifically to garments suitable for outdoor use and especially jackets suitable for outdoor use at various levels of activity and weather conditions.

- 5 There is a constant need in the market for jackets for outdoor enthusiasts that are truly light weight and comfortable across an extreme spectrum of climates, environments and uses.

At most places, weather shifts quickly, a warm evening can turn suddenly cold, and  
10 blue skies can quickly turn to rain. The body's climate can fluctuate at an even faster rate as internal temperature and perspiration levels vary during even moderate physical training. These constantly varying conditions create a need for persons being outdoor to manage his/her own personal climate. Until now persons working out or in other ways being active outdoor, have had to shed layers, bring  
15 extra layers, tie jackets around their waist, or toss them to the side in order to deal with the various climates they encounter during an outdoor activity. This effectively encumbers and slows down the outdoor person and especially outdoor athletes, and reduces their performance, comfort, and enjoyment.

- 20 The present invention introduces a micro-climate system to provide the wearer an improved capability to regulate their own personal climate, i.e. moisture and temperature, across a variety of outdoor conditions and activities - all within one garment, such as a jacket.

- 25 Many types of multilayered garments exist on the market today.

US Patent 4,292,769 describes an anti exposure inflatable structure suit designed for airmen. This structure is designed with spaced inflatable cavities and water vapour openings to prevent water from entering through the structure next to the  
30 body. Perspiration can get trapped under the structure next to the body and cannot escape creating an excessively wet environment within the jacket. The suit is breathable only at the outer layer and does not influence the internal moisture or temperature, that is, there is no ability to regulate the micro-climate around the body.

US Patent 7,013,489 describes a light weight jacket with a sealed air polymer cellular thermal layer. It is water impermeable and offers thermal protection and water buoyancy. This garment is multipurpose and intended for nautical work and outdoor use. These designs are intended for extreme climates. However, this solution is not lightweight and is therefore not applicable for a range of physical activities. As it is intended for nautical work, it is not breathable, as moisture will get locked into the suit next to the body, and there is no ability to regulate the micro-climate around the body.

Jackets and outerwear such as the above, are built for use within a specific climate spectrum, e.g. for warm and sometimes rainy weather the jacket should be waterproof and not insulated. In extremely cold and dry weather, the jacket should be heavily insulated and breathable but not water resistant. Jackets have had to be built this way to keep the jacket wearer comfortable when in that specific climate. The ability for a single jacket to provide protection, performance and comfort in a broader range of climates has been limited due to the lack of innovative materials and designs specifically targeting the micro-climate that is created by the body's' natural perspiration and heat generated around the torso.

The term "micro-climate" as it is used here, can be defined by temperature, humidity and airflow around the torso. By regulating the micro-climate around the torso, the jacket wearer can adjust to changing weather conditions as well as activity levels, e.g. more intense activities will introduce more heat and moisture in the micro-climate.

Jackets on the market today have limited versatility, because they have been designed with a specific climate in mind, e.g. the cold/dry jackets would not function well when it's warm/rainy. Because the external climate and the micro-climate within the jacket are constantly changing, the wearer is often either too warm, too cold, or too sweaty, leaving them uncomfortable as there is little opportunity to adjust their micro-climate beyond the traditional means of venting zippers – or simply removing the jacket.

It is an object of the present invention to create a garment such as a jacket that allow the wearer to adjust the micro-climate around the body, and to control his\her personal temperature, airflow and humidity at any given time. This is obtained by a jacket that provides a dramatically and surprisingly expanded range of performance, comfort and versatility.

A jacket according to the invention provides the wearer the ability to adjust the climate (temperature, airflow, humidity) within the jacket via a new design that employs four elements, that when combined, provide an improved range of comfort to consumers. The elements are:

- A first layer, preferably in the form of a breathable protective shell. The shell acts as a barrier against the elements (wind & water), while allowing the jacket to "breathe" and release excessive moisture/humidity created by the wearer.

Further the protective shell does not have to be breathable, any type of outer shell can be used.

- A mechanical ventilation system that utilizes the nature's elements. This system is designed with air flow ports, on the exterior shell of the jacket that can be opened or shut via zippers to allow the wearer to regulate the flow of air into and through the jacket. If you're cold, you use your body's natural heat generation to warm up. If you're warm, you use nature's elements, that is flowing of cool air, to cool down.

- A second layer, preferably in the form of an insulation layer, for example a fleece layer, that sits next to the exterior shell that features exaggerated air cells, i.e. articulated holes, that vary in size and spacing in the insulation layer in relation to the torso and moisture levels. The exaggerated air cells allow a larger amount of air to be captured and used in combination with the fleece to provide a substantial level of insulation vs. the cold. The exaggerated air cells also allow the wearer to regulate temperature and humidity by engaging the natural flow of air - that enters through the air flow ports to quickly vent and purge the warm air and excess humidity that gets trapped in the exaggerated air cells. The air cells can be of any shape and size.

- A third layer, preferably in the form of a mesh liner that is either hung or attached, that separates the insulation layer from the body. The mesh liner provides additional opportunities, to capture insulating air, provide greater air circulation and breathability capabilities, and as a vehicle to transport moisture away from the body.

35

If the garment does not have a mesh liner the edges of the air cells can be sewn to the outer protective shell.

The micro-climate system according to the invention works as follows. The combination of the above four elements allows the jacket wearer to effectively regulate the micro-climate inside the jacket.

5 When the wearer is cool/cold, e.g. when the wearer is in an inactive situation in a cold environment, the air flow ports are closed completely – no air flows into the jacket, the air is captured in the insulation layer, in the exaggerated air pockets, and in the pockets created by the mesh liner. The wearer gains maximum insulating value from the captured air and effectively regulates the climate within  
10 the jacket. Moreover when wearer is cold and air flow ports are closed the wearer maintains better moisture and temperature balance via the windproof/breathable shell.

When the wearer is warm, e.g. when the wearer is engaged in an aerobic or  
15 physical situation, the air flow ports are opened to their fullest, the air flow purges the warm/humid air from inside the jacket. The warm/moist air that was captured in the exaggerated air cells is quickly replaced with fresh, cool air that has entered through the air flow ports. The mesh liner facilitates the flow of air around the whole of the interior of the jacket. The combination of air flow ports, exaggerated  
20 air pockets and the mesh liner allows this climate adjustment to happen almost instantly.

In all situations, the mesh liner acts as a moisture transport vehicle, wicking the moisture away from the body / next to skin layer.

25

The invention and terms used in the above will now be further explained by way of the attached drawings of an exemplary embodiment of a garment according to the invention.

30 Fig. 1 shows an exploded view of the layers of a garment according to the invention.

Fig. 2 shows an example of an air flow port.

Fig. 3 shows an exploded view showing an insulating layer according to the invention.

35 Fig. 4 shows an exploded view showing a mesh liner.

Fig. 5 shows an exploded view showing circulation of air and moisture in a garment according to the invention.

Fig. 6 shows an example of an exaggerated air cell.

Figs. 7a and 7b shows the outer shell of a jacket according to the invention.

Figs. 8a-8c shows partly the insulating layer of the jacket on fig. 7.

Figs. 9a and 9b shows a suit according to the invention.

5 Figs. 10a and 10b shows the suit in fig. 9 partly showing the arrangement of the insulating layer.

Figs. 11a and 11b shows the suit in fig. 9 showing the mesh liner.

A garment according to the invention is made of a combination of layers having  
10 different properties. This is particularly beneficial for the use in jackets, but it can also be used in other garments used outdoor, such as jackets, pants, overalls or one piece suits or in apparel such as tents, emergency shelters, blankets or sleeping bags. In the below description of the drawings, we will refer to a jacket according to one embodiment of the invention, but it will be obvious to the reader  
15 that the description will apply also to any other use of the invention as explained above.

Fig. 1 shows an exploded view of the layers of a jacket according to the invention. The outermost layer 1 is a breathable protective shell. The layer includes an outer  
20 shell fabric, such as a polyester micro light weight ripstop which is water repellent and can function as a windstopper. The outer shell fabric can also be a textile covered with a water repellent and vapor permeable membrane 2.

Fig. 2 shows an example of an air flow port 3. In the jacket, there is provided air  
25 flow ports, being a mechanical ventilation system. The air flow ports are provided in the exterior or outermost layer 1 of the jacket and can be opened and shut via opening and locking means such as zippers, Velcro or hooks and loops, snap fasteners or other suitable locking means. The air flow ports allow the wearer to regulate the flow of air into, out of and through the jacket.

30 Fig. 3 shows an exploded view showing the insulating layer 4 of the jacket. The insulating layer is provided with exaggerated air cells 5. The insulation layer 4 is arranged under an exterior shell 6 forming the outermost layer of the jacket. The insulating layer 4 has a thickness sufficient to provide holes holding a volume, so  
35 that the holes function as air cells 5. The holes can be made by laser cutting holes in the insulating layer or by, in any other way, mechanically or chemically removing predefined parts of the insulating layer, leaving a number of holes in the layer.

The holes can also be described as exaggerated air cells, varying in size and spacing. The holes are provided throughout the jacket having sizes and patterns adapted to expected amount of moisture and heat generated on various places on the torso. For example, the back side of the jacket form a V in relation to the amount of moisture generated in this area. The holes provided in the insulating layer 4 are substantially larger than what is known from commercially available outdoor jackets at the time of filing, enabling the capture of a larger volume of heated air in the jacket.

10 The holes can be of any shape, but are preferably round, square or polygonal.

The air cells 5 allow a larger amount of air to be captured and used in combination with the insulating layer to provide a substantial level of insulation vs. the cold. The air cells 5 also allow the wearer to regulate temperature and humidity by venting and purging the warm air and excess humidity by engaging the air flow ports 3. The insulation layer 4 can for example be made of fleece, woollen fleece, tangled wool or any other material capable of forming a material with a sufficient thickness to form air cells 5.

20 Fig. 4 shows an exploded view showing a mesh liner 7 of the garment. The mesh liner is provided under the insulating layer 4 as a vehicle to transport moisture away from the body. The mesh liner 7 is the innermost layer of the jacket and form the contact surface of the jacket towards the user of the jacket. The fabric of the mesh liner is selected to provide a dry sensation for the user at any time.

25

Fig. 5 shows an exploded view showing circulation of air and moisture in a jacket according to the invention. The exterior shell 6 prevent water from penetrating the jacket when it is made of a water repellent material. Air can circulate in each air cell 5, in the insulating layer 4 and out through the exterior shell 6. Fresh air is allowed to enter the jacket, as none of the layers are air tight, thereby enabling an efficient transport of moisture away from the body of the user. In this way a micro-climate system is formed in the layers of the jacket, presenting a dynamic way of providing both insulation and ventilation.

35 Fig. 6 shows an example of an air cell 5 according to the invention. Heat generated by the body is captured in the air cells or exaggerated air cells 5. Excess heat is purged via air flow ports and to a limited extent through the exterior shell 6.

Figs. 7a-8c shows an embodiment of a jacket 8 according to the invention. Figs. 7a and 7b show the exterior shell 6 of the jacket and figs. 8a-8c shows the jacket where a part of the exterior shell 6 is visually removed from the torso of the jacket, thereby showing the insulating layer 4 of the jacket.

5

The jacket 8 according to the invention is provided with a front zipper 9 and air flow ports 3 in the form of zippers. The air flow ports 3 are arranged to be easily reachable for the user of the jacket, see fig. 8c. The air flow ports 3 are furthermore arranged so that they provide an efficient ventilation for the user.

10

On the jacket as shown on figs. 8a and 8b, the insulating layer is provided as three separate layers, with one on each side of the front zipper 9 and one on the back of the torso, leaving the sides of the jacket situated under the arms with only the exterior shell and mesh liner and no middle insulation layer. It should be noted that it is also conceivable to arrange a continuous insulating layer 4 from one side of the front zipper 9 around the torso to the other side of the front zipper.

15

Holes 5 forming the exaggerated air cells are provided in the insulating layer 4 on the torso in a predefined pattern, where larger holes are made in areas of the jacket covering areas of the torso more likely to sweat heavily and smaller holes in areas with less sweat. The larger holes will facilitate transportation of sweat away from the torso during heavy workout. If the user is slowing down, the jacket will give an improved insulation of the body as the holes are able to hold a substantial amount of hot air flowing out from the torso, between the exterior shell 6 and the mesh liner. As the back usually emits more heat, it is advantageous to provide larger holes on the back, enabling a more extensive emission of heat and humidity. On the front of the torso, the body emits less sweat and the need for transport of sweat away from the body is less significant, while it is advantageous to isolate the inner organs by minimising the flow of air away from the body. To reflect this, it is advantageous to have fewer and, if this is found profitable, smaller holes 5.

20

25

30

The presentation in figs. 7a to 8c of a micro-climate system jacket does not have an insulation layer from the arm pit and continuing from the arm pit down the side panels. Arm pit and side panels can be left uninsulated because this area does not need as much regulation. This approach, however should not preclude the ability to design a jacket that would have insulation along the panels and under the armpits. It will be obvious to the skilled person that the combination of a breathable exterior

35

layer provided with air flow ports, an insulation layer with exaggerated air cells and mesh liner may be arranged in varying ways.

In one example of the embodiment, the larger holes are about 30 mm in diameter, the medium sized holes are about 20 mm in diameter and the smaller holes are about 13 mm in diameter. In other embodiments, not shown here, other dimensions can be used.

Figs. 9a to 11b shows a suit 10 according to the invention. Figs. 9a and 9b shows the exterior shell 6 on the front and back of the suit. Figs. 10a and 10b shows the suit 10 where the exterior shell is partly removed, showing the arrangement of the insulating layer 5. Figs. 11a and 11b shows a view of the suit 10 showing the inner mesh liner 7.

The suit according to an embodiment of the invention is provided with an exterior breathable shell 6 and a front zipper 9, as shown on figs 9a and 9b. The breathable shell 6 can be water repellent and preferably vapour permeable, as explained above. There is also provided air flow ports 3 in the form of zippers on the torso and on the thighs, preferably between the legs and close to the crotch of the user, as these are areas of the body sending out a larger amount of heat and sweat. The suit is presented without arms, but it will also be possible to provide the suit with arms, if this is desirable. The arrangement of the air flow port zippers are only meant as exemplary suggestions, as the air flow ports can be arranged anywhere it is found necessary to provide extra ventilation.

Figs. 10a and 10b shows the suit 10 where a part of the exterior shell is removed, showing the arrangement of the insulating layer 4. Air cells 5 in the form of laser cut holes are provided over the front and back of the torso and on the upper part of the legs. Larger air cells 5 are provided on the back while the air cells on the front torso and legs have smaller dimensions. On this embodiment of a suit according to the invention, the crotch is provided with a mesh lining fabric instead of an insulating layer 4 provided with air cells 5. As the knees often needs extra protection and heat to prevent injuries and optimise mobility, the insulating layer 4 near the knees is left without air cells.

Figs. 11a and 11b shows a view of the suit 10 showing the inner mesh liner 7. The mesh liner 7 principally cover the inner surface of the suit 10 to provide a dry

surface of the suit, thereby giving the user a feeling of comfort both during hard workout and calm behaviour.

5 Garments according to the present invention has a number of advantages over other garments in the marketplace. The air flow ports is a simple and efficient mechanical ventilation system that uses nature's elements. The exaggerated air cells in a fleece fabric provide a substantially larger ability to hold air in the layers of a garment. The micro-climate system according to the invention presents a unique combination of a protective shell, air flow ports, exaggerated air cells in a  
10 fleece material and a mesh liner.

While the best effects of micro-climate control will be realized while combining all four elements, it is possible to combine some of the elements in unique combinations to deliver similar results.

15

It is also conceivable that a garment according to the invention can be realized through other elements that would provide enhanced insulation properties and increased air flow such as other combinations of insulation and air pockets, other synthetics, down, etc, combinations of air flow ports, insulation and exaggerated air  
20 pockets or liners that enhance air flow while providing exaggerated air pockets for insulation. However, for the garment or apparel according to the invention to work in an efficient manner, the garment should be provided with at least one breathing layer, at least one insulating layer being able of forming air cells having the properties described above and preferably at least one layer being able of  
25 transporting humidity and to some extent hold air inside the air cells of the insulating layer.

The outermost breathable layer can be a simple textile functioning as a windstopper. It can also be a more advanced material also providing water  
30 repellent and/or vapour permeable properties. In some applications of the invention, it is beneficial to provide an outermost layer including several layers, for example a textile covered with one or more membranes with different properties or a layer where one or more textiles are adhered to each other with or without one or more membranes.

35

This invention can be broadened to provide similar benefits in other applications such as technical outerwear, e.g. insulated jacket and pants, uninsulated jackets

and pants, as normal outerwear, e.g. jackets and pants, as mid-layers in jackets, pants and one piece suits, as base-layers in underwear, jackets and pants, as sportswear such as jackets, shirts and pants. It can also be applied to gloves, hats and footwear or infant apparel, such as playsuits, outerwear, hats, gloves, booties  
5 and one-piece bodysuits.

Furthermore, the concept could be adapted for use beyond apparel in areas such as tents, emergency shelters, blankets or sleeping bags.

**Claims**

1. A garment comprising at least two layers, wherein a first layer (1) is a protective shell, and a second layer (4) is an insulating layer further  
5 c h a r a c t e r i s e d i n t h a t the second layer (4) has a thickness sufficient to provide holes holding a volume of air, so that the holes function as air cells (5).
2. A garment according to claim 1, wherein an innermost layer (7) is a mesh liner.  
10
3. A garment according to claim 1, wherein the first layer (1) comprises a water repellent, vapour permeable, exterior shell (6) covering the garment.
4. A garment according to claim 1 or 2, wherein the air cells (5) are formed by  
15 mechanically or chemically removing predefined parts of material from the second layer.
5. A garment according to claim 3, wherein the air cells (5) are laser cut holes.
- 20 6. A garment according to any of the claims 1-4, wherein the first layer (1) is provided with air flow ports (3).
7. A garment according to claim 5, wherein the air flow ports (3) are in the form of  
25 zippers.

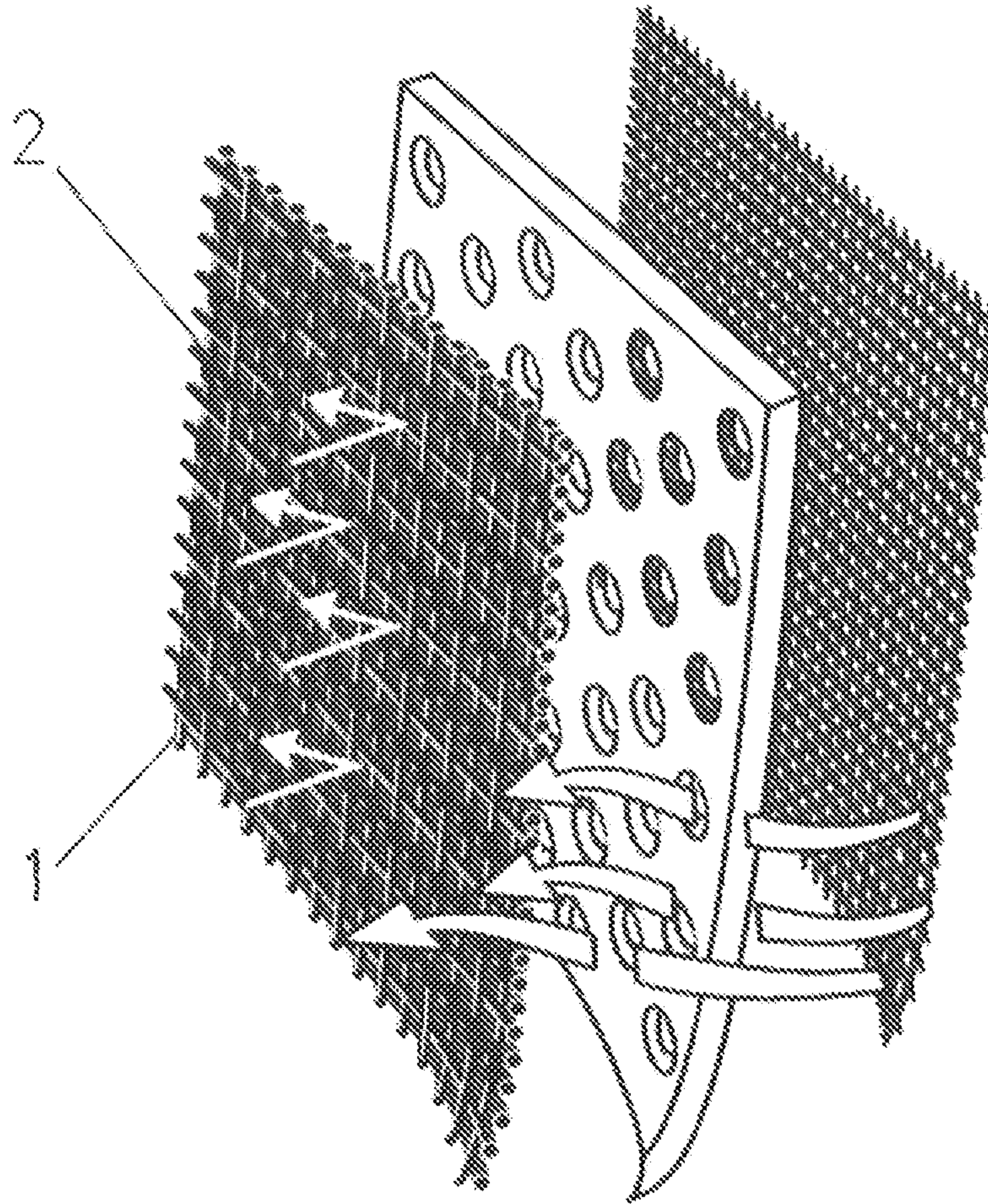

Fig. 1

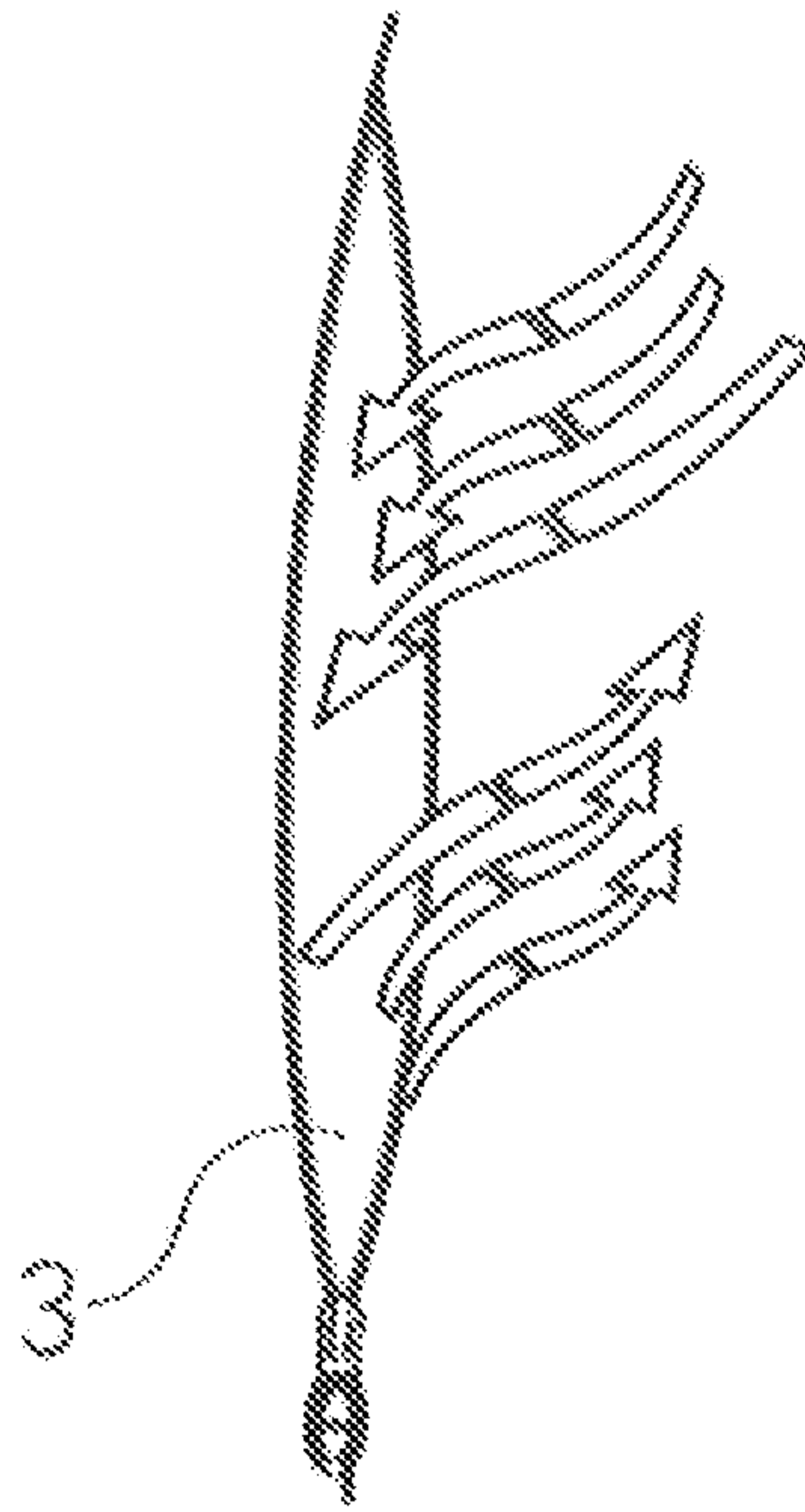

Fig. 2

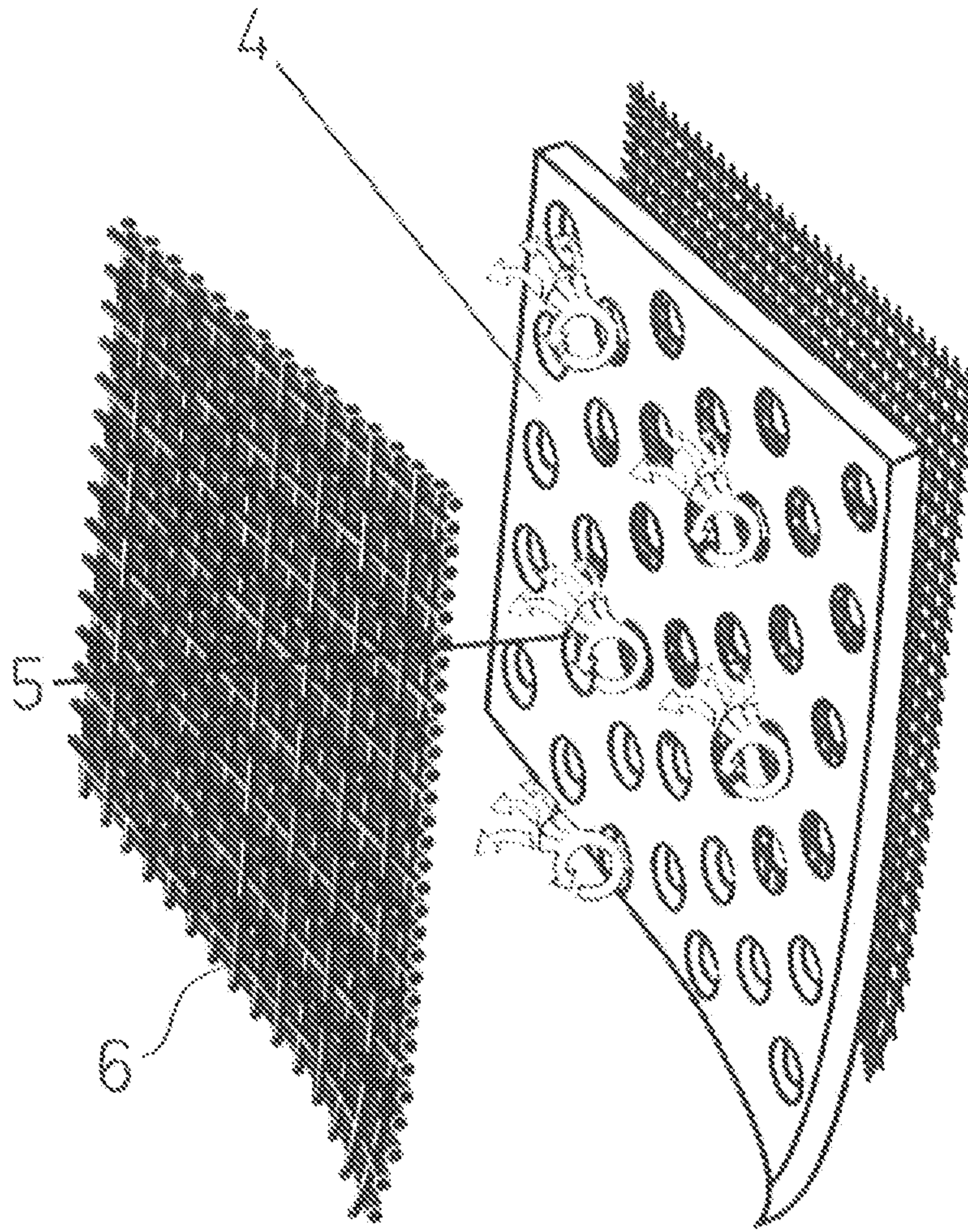

Fig. 3

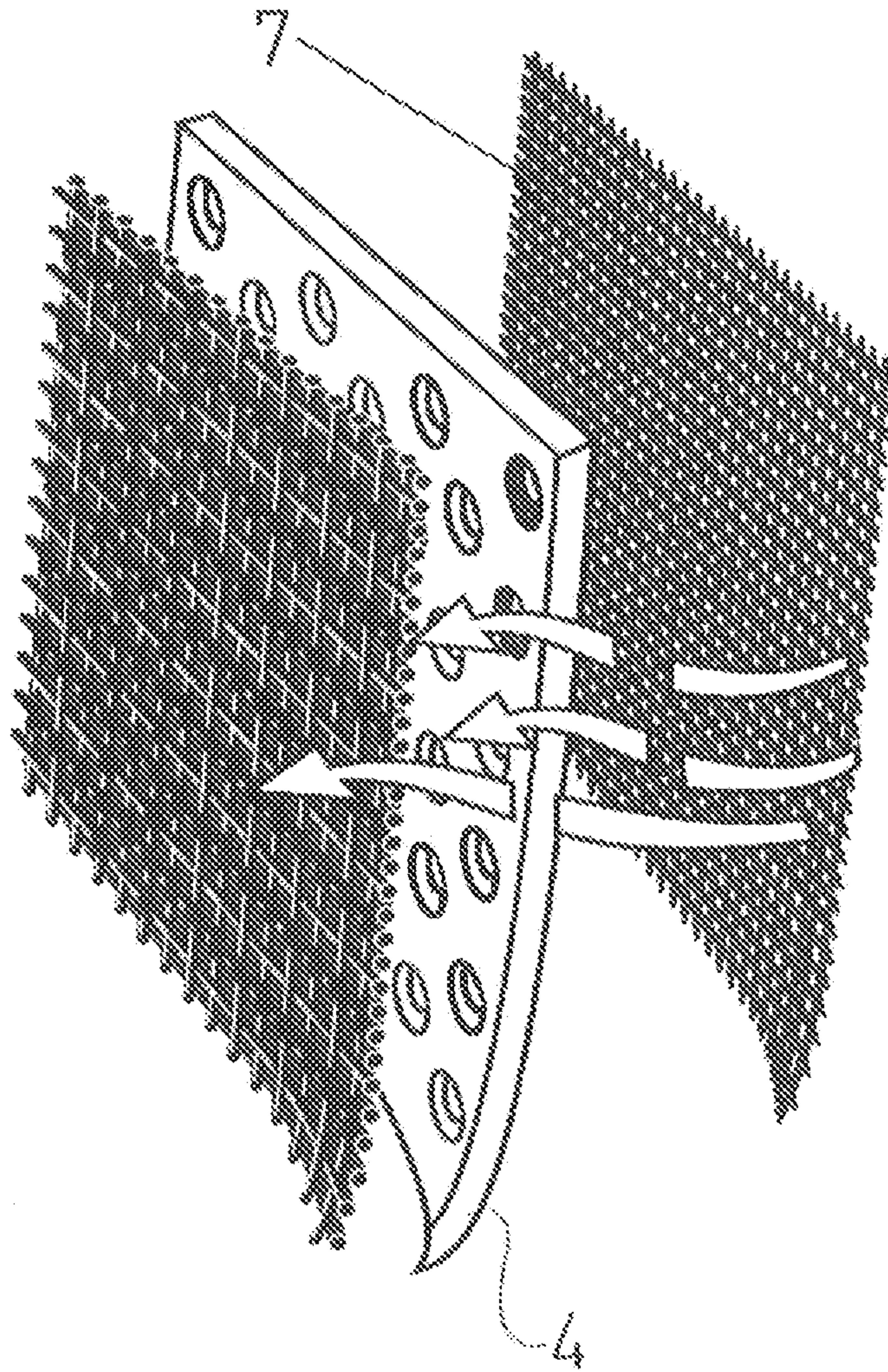

Fig. 4

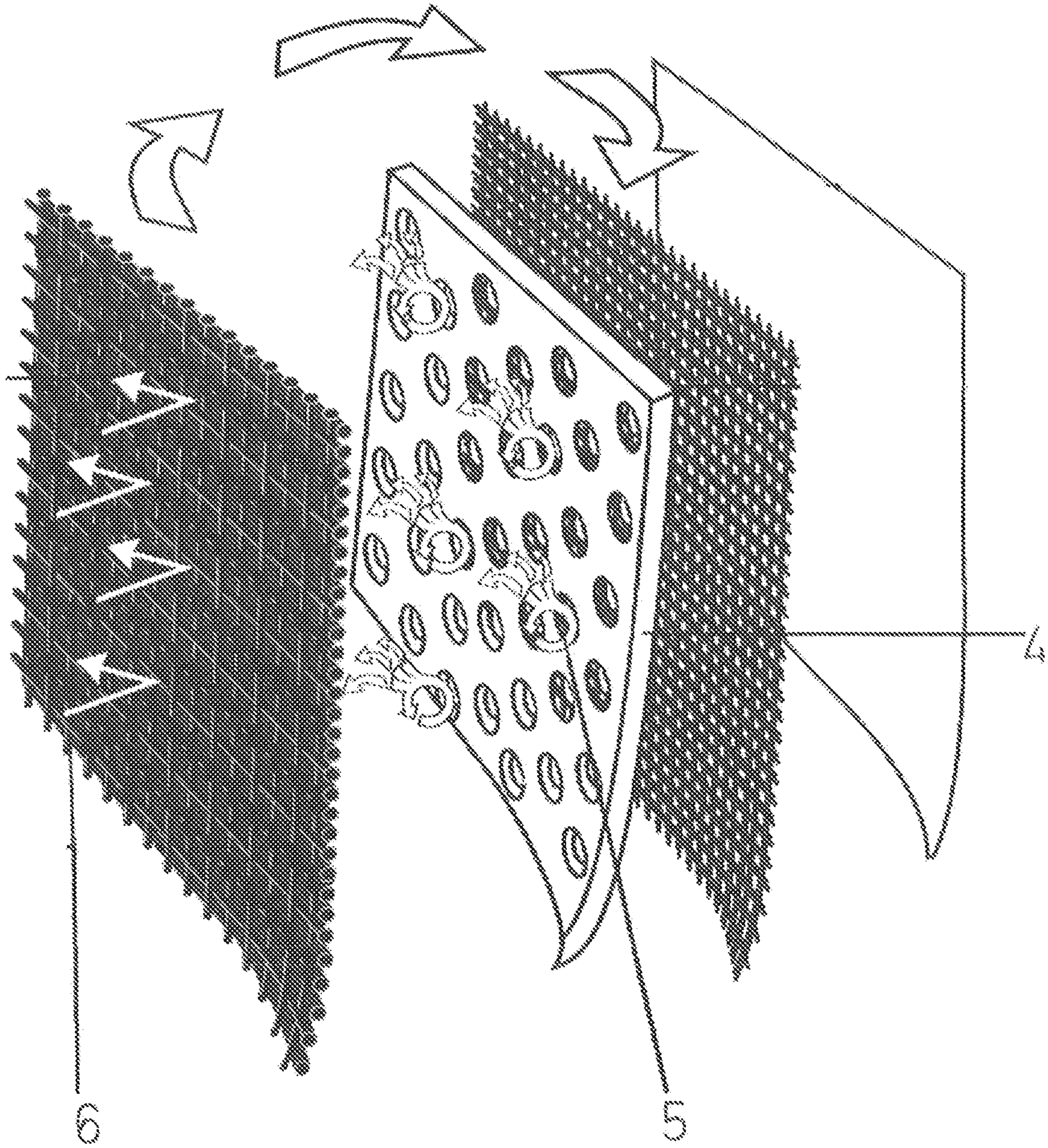

Fig. 5

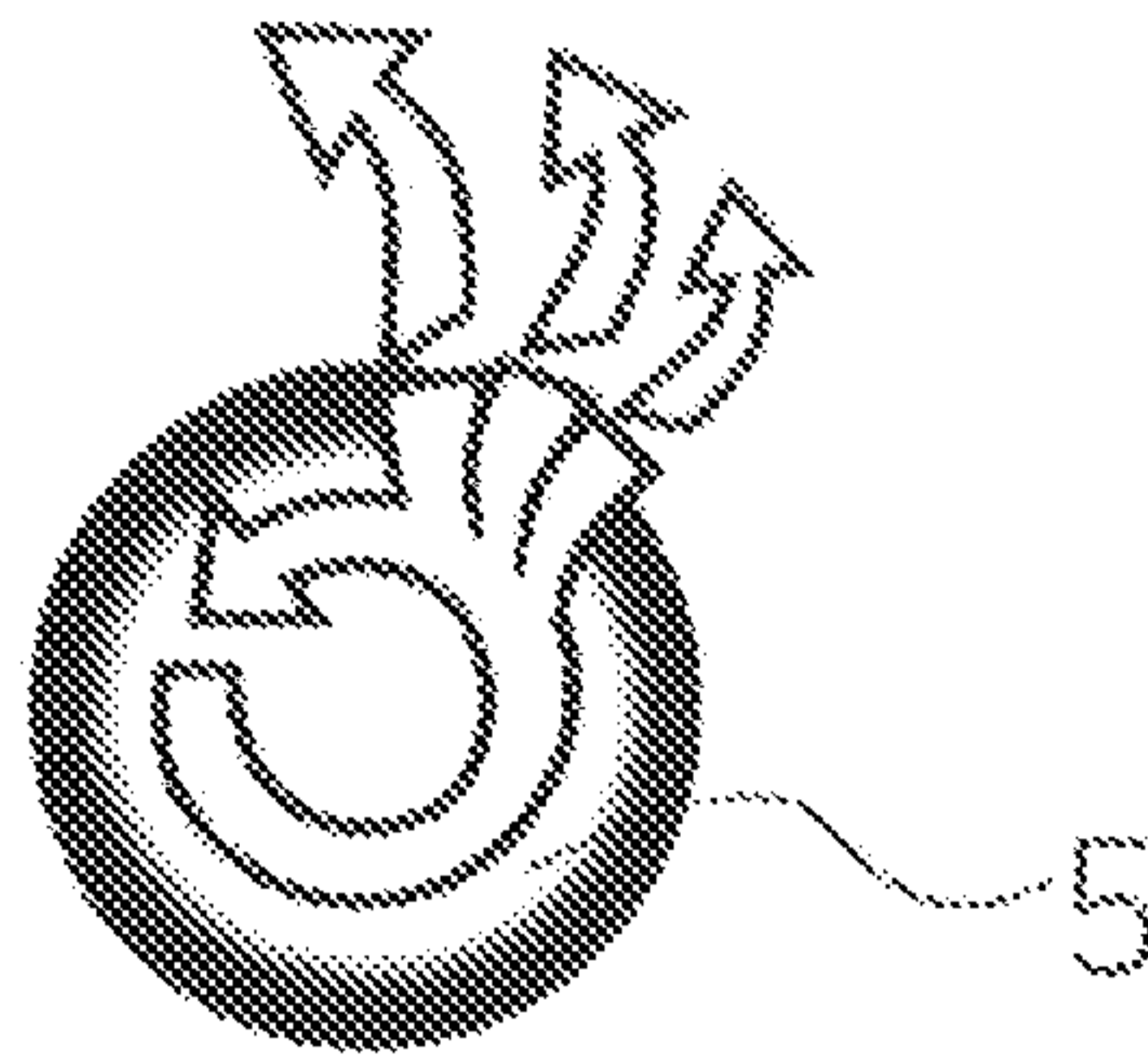

Fig. 6

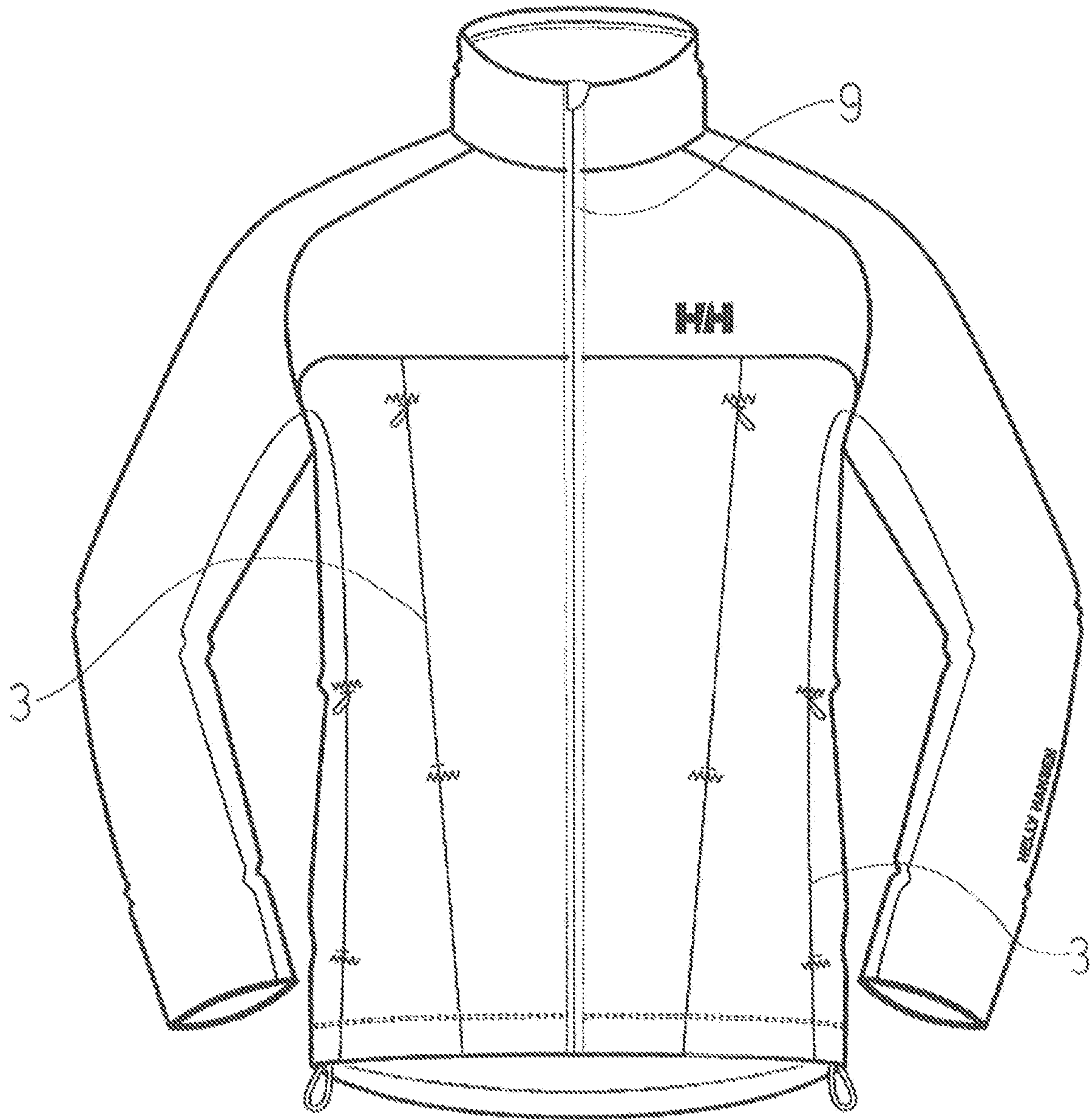

Fig. 7a

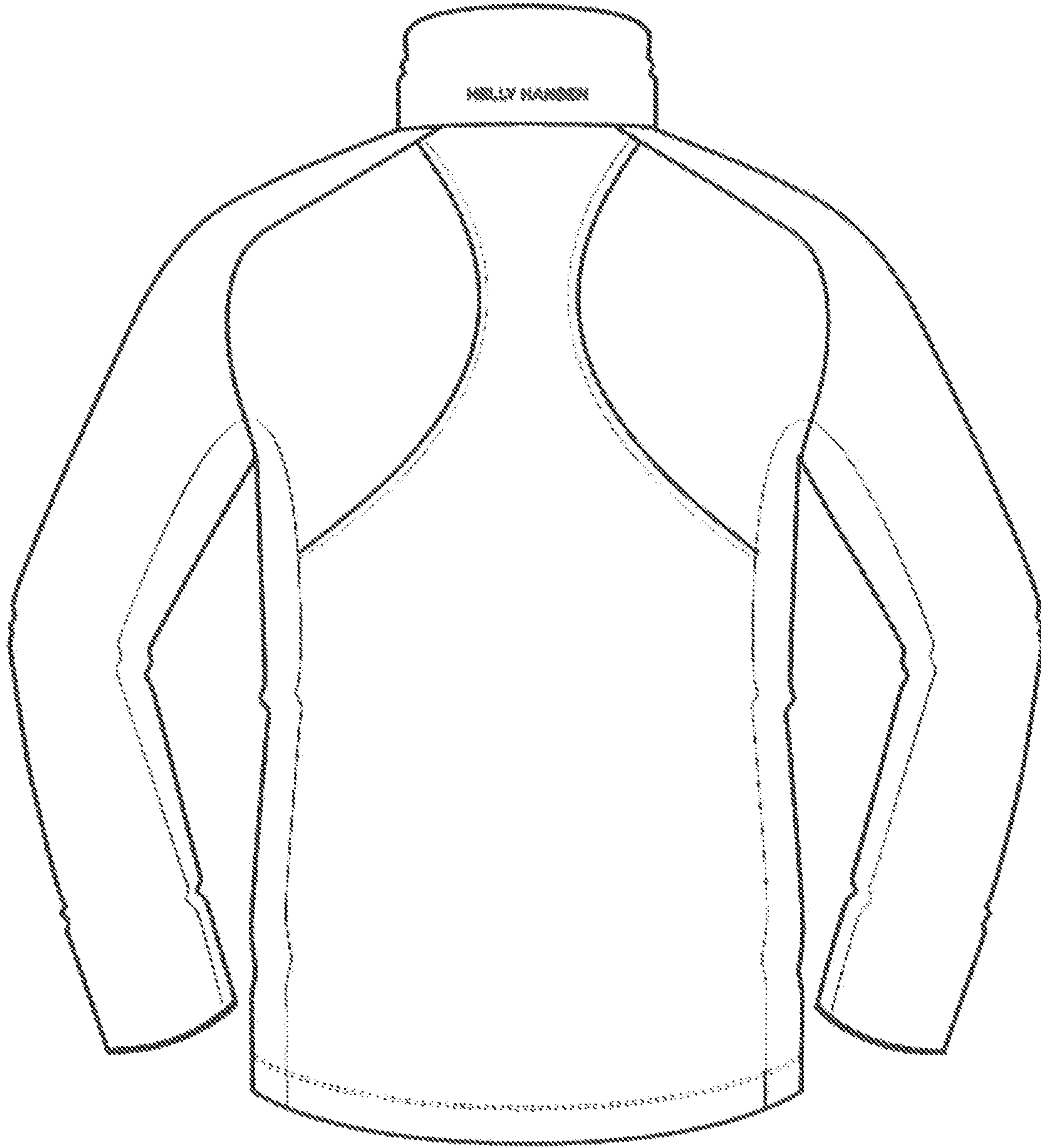

Fig. 7b



Fig. 8a

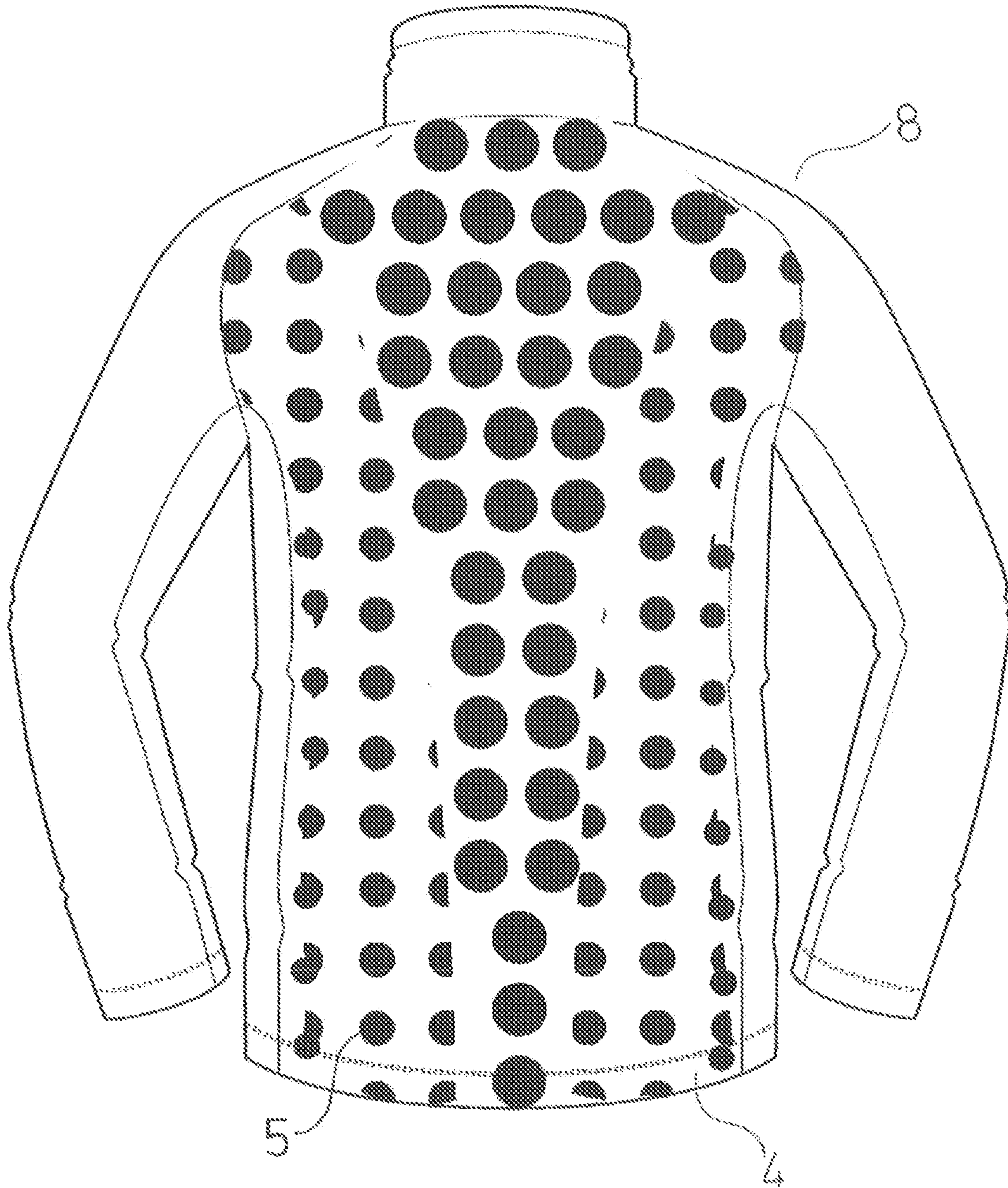

Fig. 8b



Fig. 8c

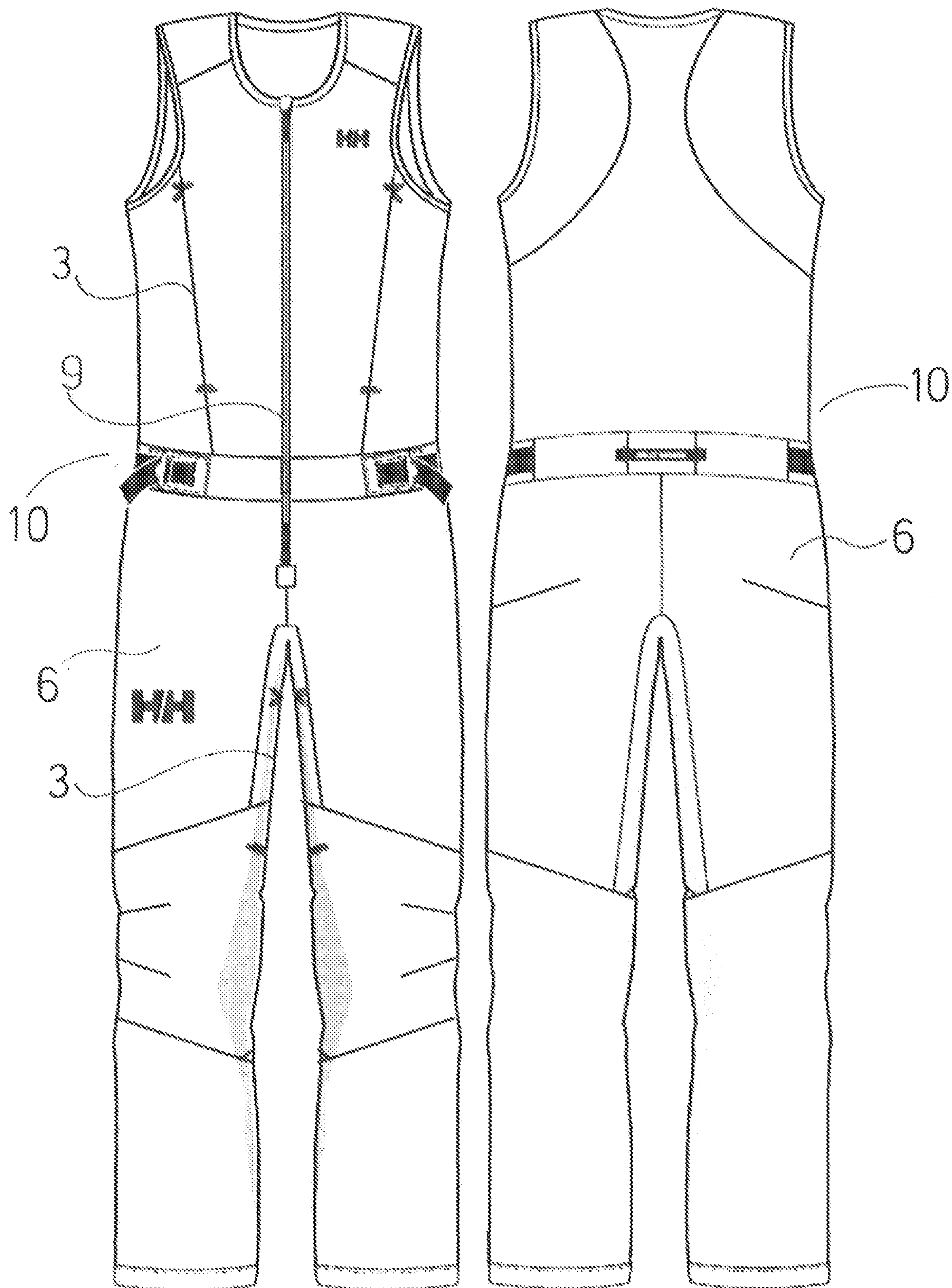

Fig. 9a

Fig. 9b

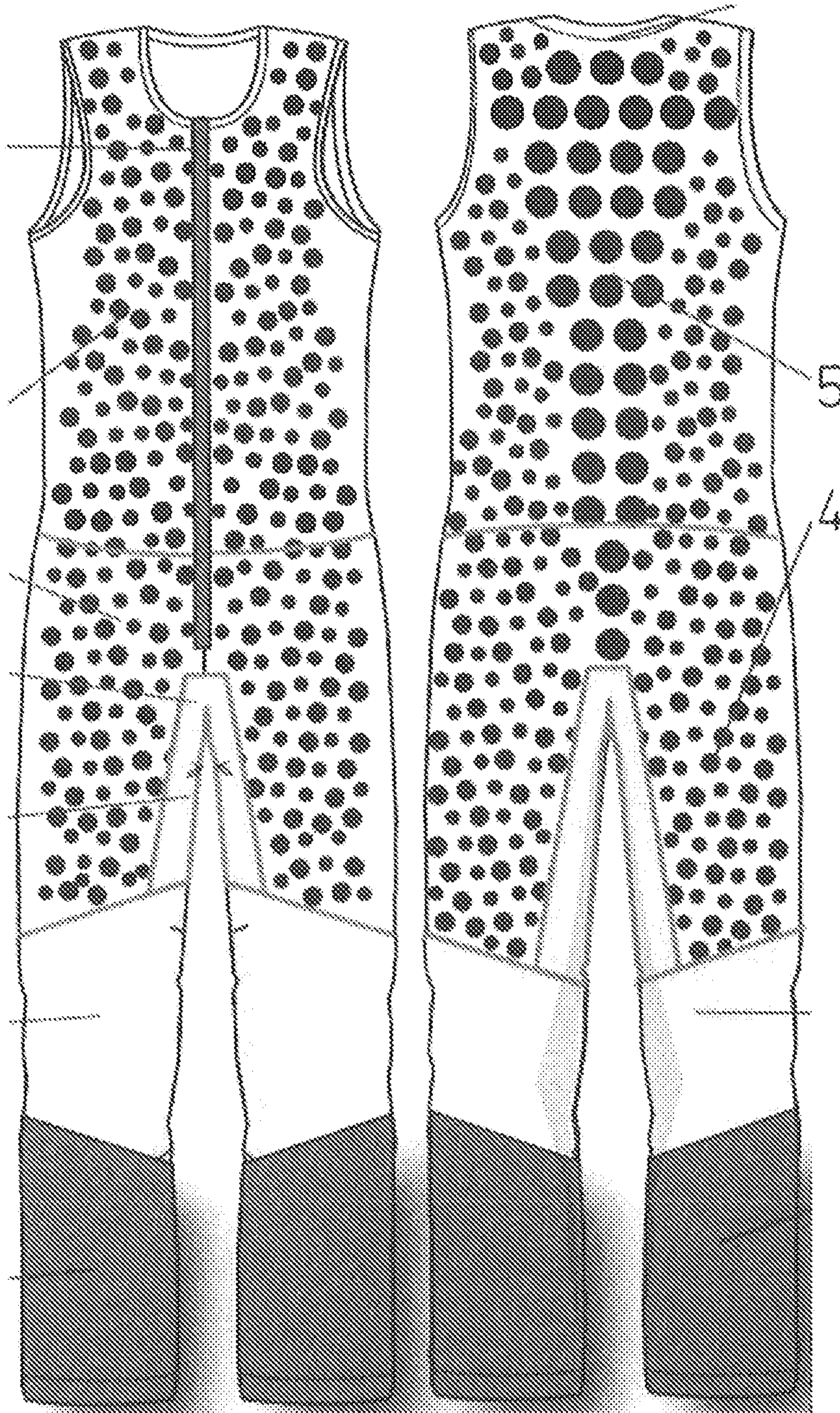

Fig. 10a

Fig. 10b

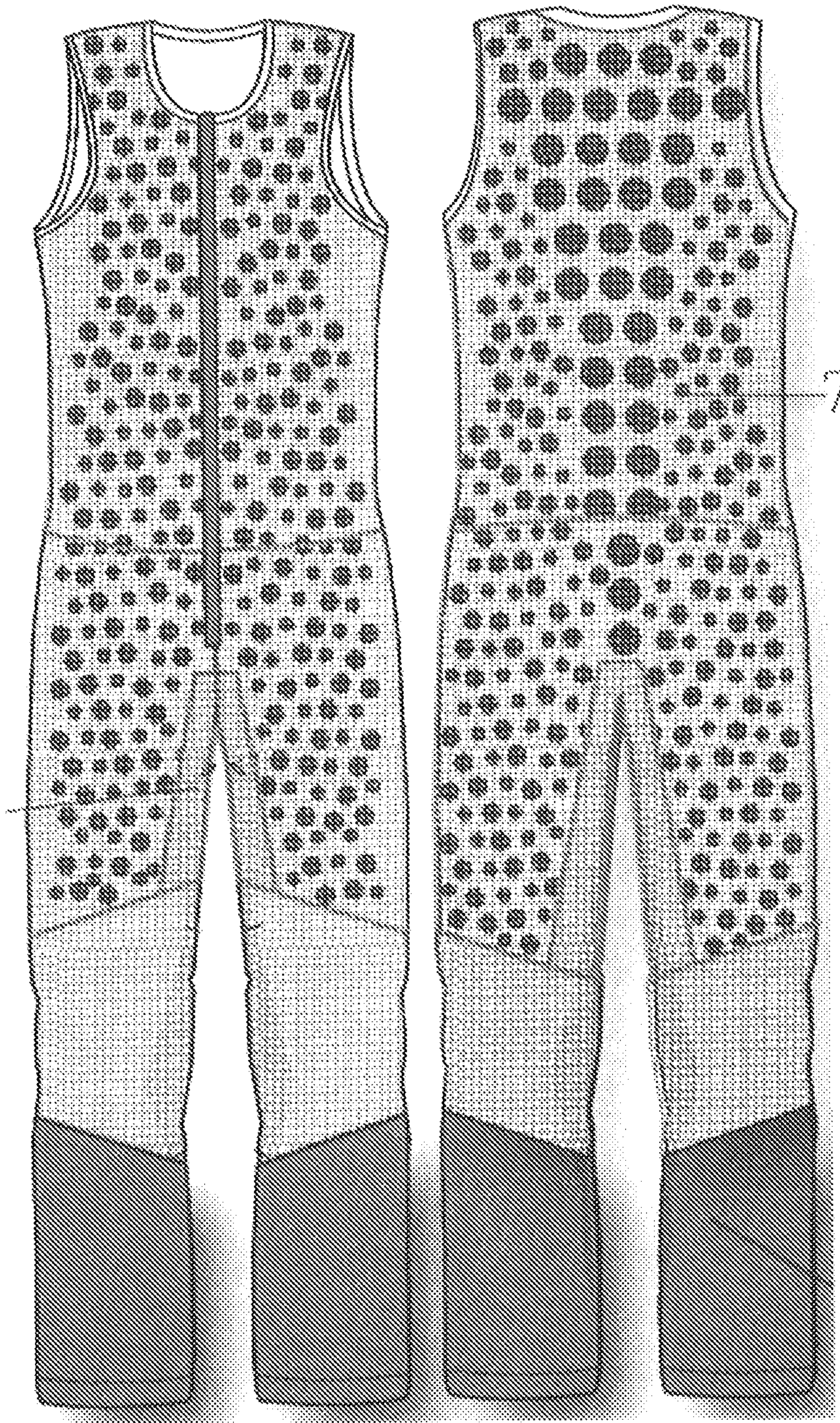

Fig. 11a

Fig. 11b



Fig. 8a