

Sept. 25, 1951

A. C. O'DAY

2,568,818

BASEBOARD RADIATOR

Filed Oct. 11, 1946

2 Sheets-Sheet 1

Fig. 1.

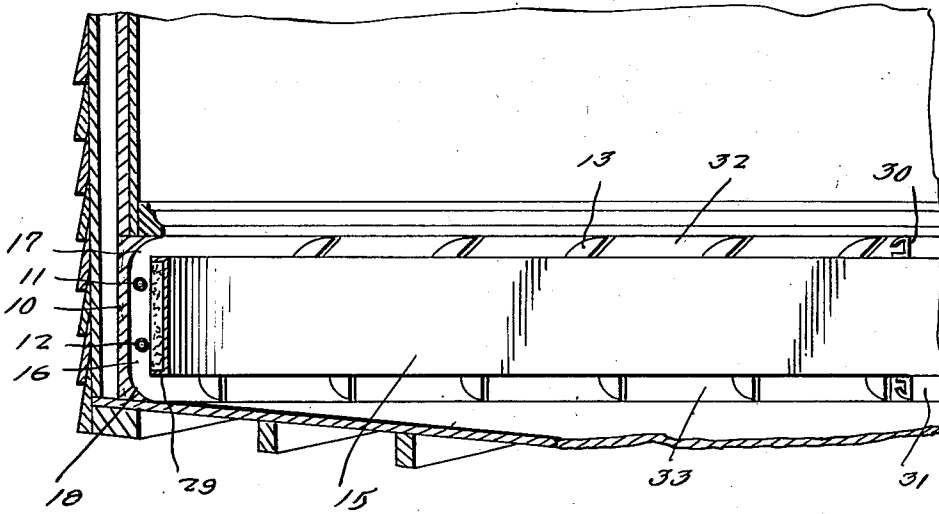

Fig. 3.

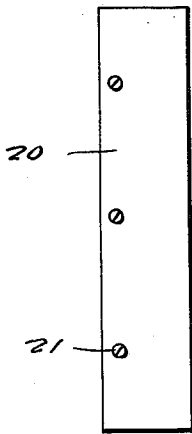

Fig. 2.

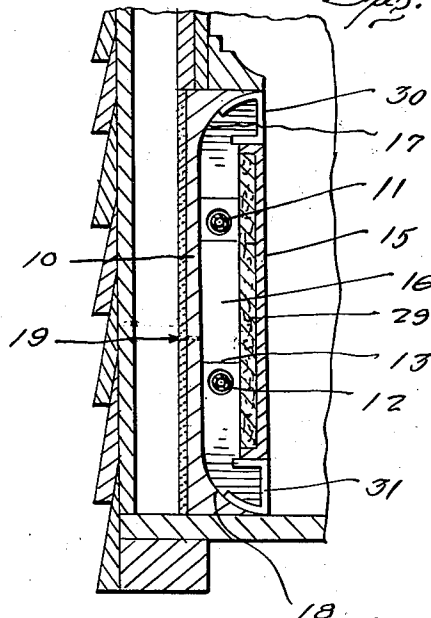
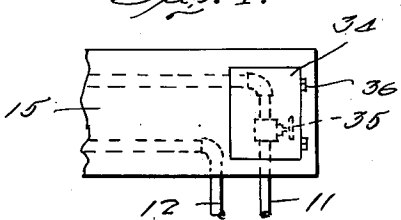

Fig. 4.



Inventor

Arthur C. O'Day

McMorrow, Berman & Davidson
Attorneys

Sept. 25, 1951

A. C. O'DAY
BASEBOARD RADIATOR

2,568,818

Filed Oct. 11, 1946

2 Sheets-Sheet 2

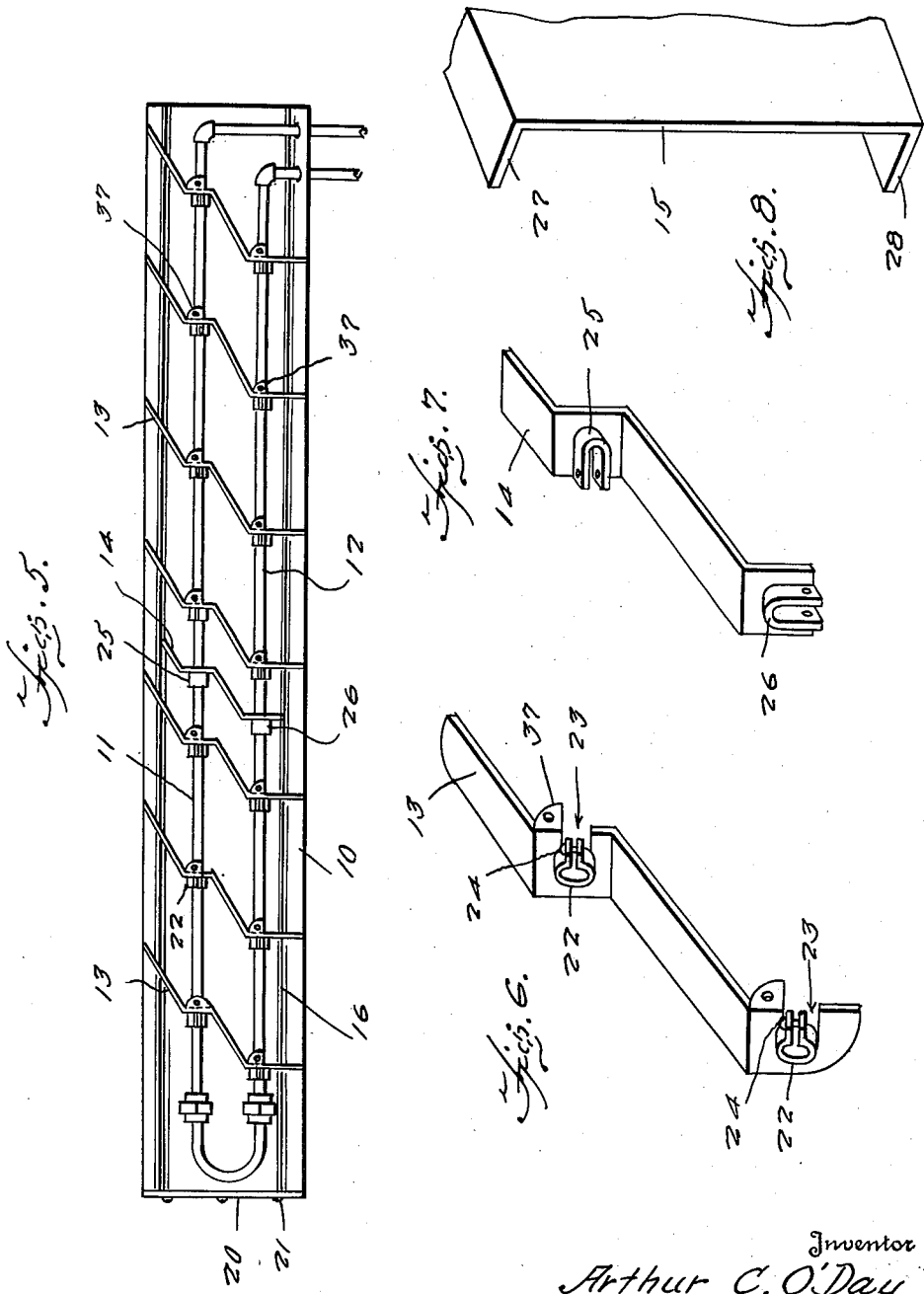

Inventor
Arthur C. O'Day

Wm. Mc Morrow, Bertram Davidson
Attorneys

UNITED STATES PATENT OFFICE

2,568,818

BASEBOARD RADIATOR

Arthur C. O'Day, Milton, Mass.

Application October 11, 1946, Serial No. 702,807

2 Claims. (Cl. 257-133)

1

This invention relates to heating equipment for use in residences, offices, public buildings, industrial plants, and the like, and in particular includes a continuous heating unit extending around the base of the walls of a room in place of the usual base board.

The purpose of the invention is to provide greater efficiency in heating and at the same time more even distribution of the heat source.

The invention generally includes a supply and a return pipe supported in heat conducting fins in a concave heat reflecting element with an insulated face plate the upper and lower edges of which are spaced from corresponding edges of the reflecting element providing circulating areas.

The object of the invention is to provide a heat exchanger or radiator in which the heat is evenly distributed around a room or the like.

Another object is to provide a radiator of the continuous convection type in which heat is supplied adjacent the floor in order to reduce cold floor areas.

A further object is to provide a radiator that may be incorporated in a wall surface so that it will not reduce floor areas, and in which all heating surfaces are hidden and enclosed providing insulated exposed surfaces that may be decorated or painted to correspond with other interior decorations of the room.

With these and other objects in view the invention embodies a back plate with an inner polished reflecting surface curved outwardly at the upper and lower edges adapted for installation in a recess at the base of a wall, two tubes or pipes, one for supply and one for return, positioned in the back plate, heat conducting supporting fins mounting the pipes in the back plate, heat radiating fins on the pipes in the back plate, an insulated face plate, and spacer elements at intervals in the areas between the edges of the face plate and back plate.

Other features and advantages of the invention will appear from the following description taken in connection with the drawings, wherein:

Figure 1 is a view showing a typical installation of the heating elements.

Figure 2 is a cross section through a wall with the heating device incorporated therein.

Figure 3 shows an end plate adapted for closing an end of the unit.

Figure 4 is a detail showing one end of the device showing a door in the end of the face plate to provide access to a control valve.

Figure 5 is a front elevation of the heater with the face plate omitted.

2

Figure 6 is a detail illustrating one of the supporting fins.

Figure 7 is a detail illustrating one of the radiating fins.

Figure 8 is a detail showing an end of the face plate.

Referring now to the drawings wherein like reference characters denote corresponding parts, the radiator, heat exchanger, or heating unit of this invention is formed with a back plate 10, an open ended supply pipe 11, and an open ended return pipe 12, supporting fins 13, radiating fins 14, and a face plate 15. The pipes are connected together by a U-shaped pipe at one end and are connected to main supply and outlet pipes respectively at the other end.

The back plate 10 is formed with a recess 16 having outwardly curved upper and lower edges 17 and 18, and the inner concave surface is preferably polished to enhance heat reflection. The rear surface may be covered with a sheet of insulating material 19, and cover plates 20 may be held to the ends by screws 21 as shown. The supply and return pipes 11 and 12 are positioned in the recess 16 and these are held by the support fins 13 in which they are secured by split clamps 22, and the fins are spot welded or brazed to the back plate. The clamps 22 are located at the inner ends of slots 23 and the flanged ends thereof may be bent outward to receive the pipes, and then bent around the pipes with the flanges held in clamping relation with screws 24 the ends of which may be threaded in the lower flanges.

Each of the support fins or brackets 13 embody a pair of steps arranged in end to end spaced parallel relation with respect to each other. A transversely disposed riser is positioned between the facing ends of the steps and secured thereto. A second riser is positioned adjacent the other end of one of said steps and dependently supported from the latter. The second riser of each bracket is supported from the floor of a room and the other end of the other step engages the back plate.

The heat radiating fins 14 are positioned intermediate of the support fins and these are directly supported on the pipes by the clamping elements 25 and 26 shown in Figure 7. These fins may be distributed to increase heat as desired.

The face plate 15 shown in Figure 8 is formed with flanges 27 and 28 for supporting insulation 29, and the upper and lower edges are spaced from the upper and lower edges of the back plate 10 by spacers 30 and 31 providing open areas 32

3

and 33 for efficient circulation of air. The spacers may be of varying lengths and may be used at points where heat is not desired, such as behind a piano, or the like.

A door 34 may be provided at a convenient point in the face plate to provide access to a valve 35, as shown in Figure 4, and the door may be mounted by hinges 36 as shown or by any suitable means. The face plate is located by the spacer elements, and is attached to the support fins through ears 37, by which it is supported.

It will be understood that changes may be made in the construction without departing from the spirit of the invention.

The construction will be readily understood from the foregoing description. In use the elements may be installed or incorporated in the base or lower part of a wall, and they may extend continuously around a room, or may be used in only one wall, or part of a wall or walls, as may be required for supplying sufficient heat. Steam, hot water, air, gas, or a refrigerant may be circulated through the pipes and particularly in heating the heated air will pass upward out of the device and this will draw cool air in the lower edge, wherein circulation will be accelerated and the room or enclosure efficiently heated.

What is claimed is:

1. A heat exchange unit for installation along a wall of a room adjacent to the juncture of said wall with the floor of said room comprising a back plate adapted to be positioned in abutting relation with respect to said wall and having its lower end resting upon the floor of said room, said back plate being flanged at its upper and lower ends, a front plate arranged in parallel spaced relation with respect to said back plate, an end plate closing each of the ends of said back and front plates, said front plate having its top and bottom edges spaced from and forming with the flanged upper and lower ends of said back plate an inlet and an outlet for air, a plurality of stepped brackets arranged in side by side spaced relation positioned in abutting relation along said back plate and secured to the latter, each of said brackets embodying a pair of steps arranged in end to end spaced parallel relation with respect to each other, a vertical riser positioned between the facing ends of said steps and secured thereto, and a second riser positioned adjacent the other end of one of said steps and dependingly supported from the latter, the second riser of each of said brackets being supported by the floor of said room with the other end of the other of said steps bearing against the adjacent portion of said back plate, the respective risers of said brackets being in alignment with each other, an open ended pipe extending through each of the aligned first and second named risers of said brackets, a connecting pipe extending between one of the open ends of said pipes and secured thereto, a second pipe connected to the other open end of said pipes and

4

other open end of one of said open ended pipes for supplying a heating medium to said one of said pipes, and a third pipe connected to the other end of said other of said pipes for withdrawing the heated medium from said other pipe.

2. A heat exchange unit for installation along a wall of a room adjacent to the juncture of said wall with the floor of said room comprising a back plate adapted to be positioned in abutting relation with respect to said wall and having its lower end resting upon the floor of said room, said back plate being flanged at its upper and lower ends, a front plate arranged in parallel spaced relation with respect to said back plate, an end plate closing each of the ends of said back and front plates, said front plate having its top and bottom edges spaced from and forming with the flanged upper and lower ends of said back plate an inlet and an outlet for air, a plurality of stepped brackets arranged in side by side spaced relation positioned in abutting relation along said back plate and secured to the latter, each of said brackets embodying a pair of steps arranged in end to end spaced parallel relation with respect to each other, a vertical riser positioned between the facing ends of said steps and secured thereto, and a second riser positioned adjacent the other end of one of said steps and dependingly supported from the latter, the second riser of each of said brackets being supported by the floor of said room with the other end of the other of said steps bearing against the adjacent portion of said plate, a split clamp on each of the risers of said brackets, the clamps of the respective risers of the respective brackets being in alignment with each other, an open ended pipe extending through the aligned split clamps on each of said first and second named risers of said brackets and detachably supported therein, a connecting pipe extending between one of the open ends of said pipes and secured thereto, a second pipe connected to the other open end of one of said open ended pipes for supplying a heated medium to said one of said pipes and a third pipe connected to the other end of said other of said pipes for withdrawing the heated medium from said other pipe.

ARTHUR C. O'DAY.

REFERENCES CITED

The following references are of record in the file of this patent:

UNITED STATES PATENTS

Number	Name	Date
1,633,032	Nordling	June 21, 1927
1,744,517	Barker	Jan. 21, 1930
1,776,080	Murray	Sept. 16, 1930
1,898,327	Wayles	Feb. 21, 1933
1,914,197	Davis, Jr. et al.	June 13, 1933
2,036,961	Collier	Apr. 7, 1936
2,228,550	Young	Jan. 14, 1941
2,243,281	Magney	May 27, 1941