

(19)



(11)

EP 2 063 063 B1

(12)

EUROPEAN PATENT SPECIFICATION

(45) Date of publication and mention of the grant of the patent:
19.02.2020 Bulletin 2020/08

(51) Int Cl.:
E06B 9/32 (2006.01) **E06B 9/327** (2006.01)
E06B 9/322 (2006.01) **E06B 9/388** (2006.01)
E06B 9/308 (2006.01)

(21) Application number: **08253603.8**

(22) Date of filing: **05.11.2008**

(54) Retractable covering for an architectural opening

Einziehbare Schirmvorrichtung für eine architektonische Öffnung

Couverture rétractable pour ouverture architecturale

(84) Designated Contracting States:
AT BE BG CH CY CZ DE DK EE ES FI FR GB GR HR HU IE IS IT LI LT LU LV MC MT NL NO PL PT RO SE SI SK TR

(30) Priority: **21.11.2007 EP 07022608**

(43) Date of publication of application:
27.05.2009 Bulletin 2009/22

(73) Proprietor: **HUNTER DOUGLAS INDUSTRIES B.V.**
3071 EL Rotterdam (NL)

(72) Inventors:
 • **Ponsen, Robert Jan**
3315 ME Dordrecht (NL)

• **Slobbe, Wilfred**
5041 DS Tilburg (NL)

(74) Representative: **J A Kemp LLP**
14 South Square
Gray's Inn
London WC1R 5JJ (GB)

(56) References cited:
EP-A2- 1 681 435 DE-A1- 3 238 473
DE-U1- 29 505 849 DE-U1-202006 015 929
US-A- 3 279 528 US-B1- 6 745 811

EP 2 063 063 B1

Note: Within nine months of the publication of the mention of the grant of the European patent in the European Patent Bulletin, any person may give notice to the European Patent Office of opposition to that patent, in accordance with the Implementing Regulations. Notice of opposition shall not be deemed to have been filed until the opposition fee has been paid. (Art. 99(1) European Patent Convention).

Description

[0001] The present invention relates to a retractable covering for architectural openings, having primary and secondary retraction mechanisms.

[0002] Architectural coverings with primary and secondary lift mechanisms are known in the art. Such architectural coverings are generally intended for escape openings in building structures. The secondary lift mechanism thereby provides an emergency drive that is preferably automatically activated in emergency situations such as in case of a fire. Such a secondary lift mechanism is known from German patent reference DE 3238473, which uses a spring motor to wind a separate lift tape for raising its bottom rail. When the secondary lift mechanism operates the separate lift tape, the regular lift tape of the primary lift mechanism will be gathered in an uncontrolled manner between the slats of the blind. This may inhibit or distort subsequent operation of the primary lift system. European patent reference EP 1681435 also discloses the use of a spring drive for a secondary lift mechanism. Again the secondary lift mechanism uses lift tapes that are separate from the lift tapes for the primary operating mechanism. This results in a similar drawback of the primary lift tapes of being gathered in an uncontrolled fashion. US 3,279, 528 describes a roller shade having conical spools at each end of a roller for a shade. As the shade unwinds one end of a cord is wound around one spool. The cord extends down one side of the shade, through a rod at the bottom of the Shade and along the other side of the shade. The other end of the cord is similarly wound around the other spool as the shade unwinds. One of the spools is rotationally biased so as to keep the cord under tension.

[0003] Accordingly it is an object of the present invention to overcome or ameliorate at least one of the disadvantages of the prior art. It is also an object of the present invention to provide alternative structures which are less cumbersome in assembly and operation and which moreover can be made relatively inexpensively. Alternatively it is an object of the invention to at least provide the public with a useful choice.

[0004] To this end the invention provides a retractable covering device as defined in appended claim 1. The arrangement of sharing one and the same flexible element between two independent retraction mechanism solves one of the major inconveniences of the prior art.

[0005] Preferably, the retractable covering device according to the invention includes further features as defined in dependent claims 2 to 11.

[0006] One advantageous embodiment of the retractable covering device according to the invention further comprises a head rail on a second edge of the covering member opposite the bottom rail, and wherein both the first and secondary retraction mechanisms are associated with the head rail. This makes for a compact arrangement of the retractable covering device with both retraction mechanisms concentrated on one side of the blind

and thereby enabling the bottom rail having the least obtrusive contours. In this regard it is further advantageous when the bottom rail is provided with at least one guide element and wherein the at least one flexible element is looped around the at least one guide element to define a first branch extending from the head rail to the at least one guide element and a second branch extending from the at least one guide element to the head rail and parallel to the first branch of the at least one flexible element. In a further advantageous embodiment of the invention the primary retraction mechanism has a first axis of rotation and the secondary retraction mechanism has a second axis of rotation and the second axis of rotation therein is parallel to the first axis of rotation. Thereby it is further advantageous when a first plane is defined that is common to the first and second axes of rotation, which first plane is perpendicular to a second plane that is common to the head and bottom rails in an extended position of the collapsible covering member. These optional features will make it possible to also fit the retractable covering device according to the invention in spaces into which otherwise only conventional retractable covering device would fit.

[0007] Preferably, the at least one flexible element extends in a third plane that intersects the first plane common to the first and second axes of rotation substantially between the first and second axes of rotation.

[0008] Preferably, the third plane is co-extensive with the second plane and wherein the at least one flexible element is deflected from the primary retraction mechanism towards the second plane by a first guide means and from the secondary retraction mechanism towards the second plane by a second guide means.

[0009] Preferably, the first guide means is a deflection pin and wherein the second guide means is a guiding roller.

[0010] Generally it is also advantageous for the retractable covering device according to the invention when the secondary retraction mechanism includes a spring motor. This type of drive can be pretensioned to provide for a rapid operation in case of an emergency.

[0011] Still further advantageous embodiment will become apparent from the following description and appended claims.

[0012] The invention will now be explained in reference to the accompanying drawings, in which:

- Figure 1 is a compound perspective, sectioned view of a retractable covering device according to the invention, in which section [A] corresponds to a version using a first type of side guiding and section [B] corresponds to a version using a second type of side guiding;
- Figure 2 is an elevation of the compound sectioned view of Figure 1 in the direction of arrows II-II;
- Figure 3 is a cross-sectional view taken along the line III-III in Figure 2; and
- Figure 4 is a cross-sectional view taken along the

line IV-IV in Figure 2.

[0013] In Figure 1, the reference numerals 1A and 1B generally indicate two slightly different versions of a Venetian blind incorporating the invention. The left hand portion (Figure 1 [A]) illustrates a Venetian blind 1A, that includes a head rail 3, a collapsible covering member comprising a plurality of slats 5 and a bottom rail 7. The slats 5 are each supported by a flexible ladder support 9 as is conventional with Venetian blinds. The slats 5 of the blind 1A are each guided and retained in vertical alignment by a side guiding arrangement using a rod or tensioned cable 11 extending through apertures 13 at the longitudinal ends of the slats 5. Similarly, the right hand portion (Figure 1 [B]) represents a portion or a Venetian blind 1B, having a head rail 3, slats 5 and a bottom rail 7. The slats 5 are each supported by a flexible ladder support 9 and as such the right hand section of version [B] would be similar to a right-hand portion of the left-hand section of version [A]. The difference is that version [B] has a channel shaped side guide rail 15 in which slat guiding pins (not shown, but conventional) ride along the guide rail 15. Such guiding pins may be attached in the apertures 13 and extend from the longitudinal end of a relevant slat 5. The skilled person will be familiar with the exchangeability of the side guiding details and will easily conceive the execution of the right-hand portion of blind version [A] or the left-hand portion of blind version [B]. Of the lowest slat 5 in Figure 1, only the contours are shown to reveal more detail of the bottom rail 7.

[0014] Also visible in Figure 1 is that the blind 1A, 1B has openings 17 in the slats 5 for the passage of flexible elements 19 for raising the bottom rail 7 and collapsing the slats 5 and ladder supports 9 against the head rail 3 to retract the Venetian blind 1A, 1B. The bottom rail 7 is further provided with guide elements 21, which are associated with each support ladder 9 for a purpose to be described herein below. Associated with the head rail 3 is a primary retraction mechanism 23 and a secondary retraction mechanism 25. The primary retraction mechanism 23 is preferably a conventional motorized mechanism for raising and lowering a window covering that is controlled by a conventional electric switch or remote control unit (not shown).

[0015] In Figure 2, a rear elevation of the blind of Figure 1, the same components are referenced by the same reference numerals. The longitudinal ends of the head rail 3 are connected with a respective first end bracket 27 and second end bracket 29. The first and second end brackets 27, 29 are fixedly attached to the respective longitudinal ends of the head rail 3 and each are adapted to carry one end of the secondary retraction mechanism 25, which is in the form of a spring motor roller having mounted thereon a first and a second rotatable secondary winding reel 31, 33. The elongated spring roller motor of the secondary retraction mechanism 25 is arranged in parallel relationship with the head rail 3. The first and second end brackets 27, 29 are each provided with a

relevant first and second mounting flange 35, 37. When a cable or rod side guiding 11 is provided, this can also be attached to the end bracket 27 or 29 by means of an anchor strip 39. Also attached to the head rail 3 are a first pair of spaced arms 41 and a second pair of spaced arms 43. The first and second pair of arms each form a cradle for rotatably supporting a relevant first and second guiding rollers 45, 47 and first and second deflection pins 49, 51 (see Figures 3 and 4) for a purpose to be described.

[0016] Figure 3 is a cross-section taken along the line III-III in Figure 2. The flexible lift element 19 has a first branch 19A extending downwardly from the primary retraction mechanism 23, over the deflection pin 51 (or the similar deflection pin 49 as the case may be), towards a return roller 53 in the guide element 21. The primary retraction mechanism 23 is provided with a rotatable primary winding reel 55 onto, or from, which a first end of the flexible element 19 can be wound or unwound as desired. From the return roller 53 a second branch 19B of the flexible element 19 extends upwardly to the second guide roller 47 (or the first guide roller 45 as the case may be) to have its second end wound by the second secondary winding reel 33 (or first secondary winding reel 31 as the case may be).

[0017] The reference "P" in Figures 3 and 4 denotes an exemplary guiding pin for use with a side guiding rail (reference "15" as indicated in Figures 1 and 2). Figure 4, which is a cross-section along the lines IV-IV of Figure 2, shows in more detail one of the ladder supports 9. Each ladder support 9 has a first branch 9A and a second branch 9B which both extend from a tilt mechanism associated with the primary retraction mechanism 23. This tilt mechanism is not shown, but is conventional for combined mono-commando type tilting and lifting mechanisms with which the skilled person is familiar. In the present context a detailed description of such devices is thus deemed redundant. The first branch 9A of the ladder support 9 is deflected towards a plane in which the flexible element 19 extends downwardly towards the guide element 21 on the bottom rail 7. The first branch 9A is connected to a second branch 9B which extends upwardly from the guide element 21 along opposite edges of slats 5, back to the tilting mechanism associated with the primary retraction mechanism 23. The interconnected first and second branches enable the ladder support 9 to extend through a funnel through the guide element 21 and to effect tilting of the slats without altering the position of the bottom rail 7. The first and second branches 9A, 9B are each connected with opposite ones of the longitudinal edges of slats 5 at points 59A and 59B. This interconnection can be accomplished by any suitable conventional means as known to the skilled person. It is also possible to support the slats 5 between cross-rungs, extending between points 59A and 59B of the first and second branches of the ladder support 9. Also this system is well known to the skilled person and will not require any further explanation.

[0018] The operation of the retractable covering device as described in relation to Figures 1 to 4 is as follows. Each of the primary and secondary retraction mechanisms 23, 25 are adapted to raise the bottom rail 7 by winding a relevant first or second end of the flexible element 19. When the primary retraction mechanism 23 lifts the bottom rail, it will be lifted with half the speed at which the first branch 19A of the flexible element is wound. This will basically reduce the force required to raise a relatively heavy blind, which may be an advantage to the general applicability of the primary retraction mechanism 23. The further advantage obtained is that there will be no flexible lift element of the secondary retraction mechanism that is compromised or distorted by the lifting action of the primary retraction mechanism. Conversely also the secondary retraction mechanism 25 may lift the bottom rail 7 through winding of the second branch 19B of the flexible element 19 in case of an emergency. Again this action will not compromise or interfere with the operation of the primary retraction mechanism 23. To achieve this, the secondary retraction mechanism 25 may be provided with a very strong spring motor which may actually accelerate the movement of bottom rail 7 towards the head rail 3. Thereby the flexible covering member formed by the slats 5 and the ladder supports 9 is collapsed between the bottom rail 7 and the head rail 3. To achieve a quick operation of the secondary retraction mechanism 25, the head rail 3 can be provided with an operation device 61 (see Figure 1) that is adapted to withdraw a latch 63 from a circumferential cavity 65 provided in a collar 67 of the secondary retraction mechanism 25 (Figures 1 and 4).

[0019] The operation device 61 can be remotely controlled by a fire alarm or may be a mechanical device that is responsive to temperature or smoke conditions that can be associated with a fire in a building. Also the operation device can be manually controlled from a button or handle in the close proximity of the escape opening with which the blind is associated. The skilled person will generally be familiar with other suitable mechanisms for withdrawal of the latch 63 that are both effective and compliant with the applicable regulations.

[0020] It is thus believed that the operation and construction of the present invention will be apparent from the foregoing description and accompanying drawing figures. The invention is not limited to any embodiment herein described and, within the purview of the skilled person; modifications are possible which should be considered within the scope of the appended claims. Equally all kinematical inversions are considered inherently disclosed and to be within the scope of the present invention. The term comprising when used in this description or the appended claims should not be construed in an exclusive or exhaustive sense but rather in an inclusive sense. Expressions such as: "means for ..." should be read as: "component configured for ..." or "member constructed to ..." and should be construed to include equivalents for the structures disclosed. The use of expressions like: "critical", "preferred", "especially preferred" etc. is not in-

tended to limit the invention.

Claims

1. Retractable covering device for architectural openings, including:

a collapsible covering member;
a bottom bar (7), positioned along a first edge of the collapsible covering member;
at least one flexible element (19) in engagement with the bottom bar (7) for raising the bottom bar (7) and collapsing the covering member to define a retracted position of the covering;
a primary retraction mechanism (23) for retracting the at least one flexible element (19) from a first end of the at least one flexible element (19); and

a secondary retraction mechanism (25) operatively connected with the bottom bar (7);
wherein the primary retraction mechanism (23) includes at least one rotatable primary winding reel (55) to which a first end of the at least one flexible element (19) is attached, the first end of the flexible element (19) being wound or unwound onto, or from the at least one rotatable primary winding reel;

wherein the secondary retraction mechanism (25) includes at least one rotatable secondary winding reel (33);

whereby the primary retraction mechanism (23) is configured to retract the covering member when retracting the at least one flexible element (19) from the first end of the at least one flexible element (19);

and whereby the primary retraction mechanism (23) is independent of the secondary retraction mechanism (25);

characterized in that the secondary retraction mechanism (25) is arranged for retracting the at least one flexible element (19) from a second end of the at least one flexible element (19); that the second end of the at least one flexible element (19) is attached to the at least one rotatable secondary winding reel (33); and that the secondary retraction mechanism (25) is configured to selectively also retract the covering member when retracting the at least one flexible element (19) from the second end of the at least one flexible element (19).

2. Retractable covering device according to claim 1, wherein the collapsible covering member includes a plurality of elongate slats (5), kept in a mutually parallel and spaced arrangement by at least two flexible suspension ladders (9), which are spaced from one another along the length of the slats (5).

3. Retractable covering device according to claim 1 or 2, further comprising a head rail (3) on a second edge of the covering member opposite the bottom rail (7), and wherein both the first and secondary retraction mechanisms (23, 25) are associated with the head rail (3). 5
4. Retractable covering device according to claim 3, wherein the bottom rail (7) is provided with at least one guide element (21) and wherein the at least one flexible element (19) is looped around the at least one guide element (21) to define a first branch (19A) extending from the head rail (3) to the at least one guide element (21) and a second branch (19B) extending from the at least one guide element (21) to the head rail (3) and parallel to the first branch (19A) of the at least one flexible element (19). 10 15
5. Retractable covering device according to one of claims 1 to 4, wherein the secondary retraction mechanism (25) includes a spring motor. 20
6. Retractable covering device according to one of claims 1 to 5, wherein the at least one flexible element (19) is a lift tape and retraction of the covering member can be accomplished by lifting of the bottom rail (7). 25
7. Retractable covering device according to one of claims 1 to 6, wherein the primary retraction mechanism (23) has a first axis of rotation and the secondary retraction mechanism (25) has a second axis of rotation and wherein the second axis of rotation is parallel to the first axis of rotation. 30 35
8. Retractable covering device according to claim 7, wherein a first plane is defined that is common to the first and second axes of rotation, which first plane is perpendicular to a second plane that is common to the head (3) and bottom (7) rails in an extended position of the collapsible covering member. 40
9. Retractable covering device according to claim 8, wherein the at least one flexible element (19) extends in a third plane that intersects the first plane common to the first and second axes of rotation substantially between the first and second axes of rotation. 45
10. Retractable covering device according to claim 9, wherein the third plane is co-extensive with the second plane and wherein the at least one flexible element (19) is deflected from the primary retraction mechanism (23) towards the second plane by a first guide means and from the secondary retraction mechanism (25) towards the second plane by a second guide means. 50 55

11. Retractable covering device according to claim 10, wherein the first guide means is a deflection pin (49, 51) and wherein the second guide means is a guiding roller (45, 47).

Patentansprüche

1. Einziehbares Abdeckvorrichtung für architektonische Öffnungen, die Folgendes beinhaltet:

ein zusammenlegbares Abdeckelement, eine untere Leiste (7), die entlang einer ersten Kante des zusammenlegbaren Abdeckelements positioniert ist; mindestens ein flexibles Element (19) in Eingriff mit der unteren Leiste (7) zum Anheben der unteren Leiste (7) und Zusammenlegen des Abdeckelements, um eine eingezogene Position der Abdeckung zu definieren; einen primären Einziehmechanismus (23) zum Einziehen des mindestens einen flexiblen Elements (19) von einem ersten Ende des mindestens einen flexiblen Elements (19); und einen sekundären Einziehmechanismus (25), der mit der unteren Leiste (7) wirkverbunden ist; wobei der primäre Einziehmechanismus (23) mindestens eine drehbare primäre Aufwickelrolle (55) beinhaltet, an der ein erstes Ende des mindestens einen flexiblen Elements (19) befestigt ist, wobei das erste Ende des flexiblen Elements (19) aufgewickelt oder abgewickelt wird, oder von der mindestens einen drehbaren primären Aufwickelrolle; wobei der sekundäre Einziehmechanismus (25) mindestens eine drehbare sekundäre Aufwickelrolle (33) beinhaltet; wobei der primäre Einziehmechanismus (23) konfiguriert ist, um das Abdeckelement einzuziehen, wenn das mindestens eine flexible Element (19) von dem ersten Ende des mindestens einen flexiblen Elements (19) eingezogen wird; und wobei der primäre Einziehmechanismus (23) unabhängig von dem sekundären Einziehmechanismus (25) ist; **dadurch gekennzeichnet, dass** der sekundäre Einziehmechanismus (25) zum Einziehen des mindestens einen flexiblen Elements (19) von einem zweiten Ende des mindestens einen flexiblen Elements (19) angeordnet ist; dass das zweite Ende des mindestens einen flexiblen Elements (19) an der mindestens einen drehbaren sekundären Aufwickelrolle (33) befestigt ist; und dass der sekundäre Einziehmechanismus (25) konfiguriert ist, um das Abdeckelement selektiv auch einzuziehen, wenn das mindestens eine flexible Element (19) von dem zweiten Ende des min-

- destens einen flexiblen Elements (19) eingezo-
gen wird.
2. Einziehbare Abdeckvorrichtung nach Anspruch 1,
wobei das zusammenlegbare Abdeckelement eine
Vielzahl von länglichen Lamellen (5) beinhaltet, die
durch mindestens zwei flexible Hängeleitern (9) in
einer zueinander parallelen und beabstandeten An-
ordnung gehalten werden, die entlang der Länge der
Lamellen (5) voneinander beabstandet sind. 5
 3. Einziehbare Abdeckvorrichtung nach Anspruch 1
oder 2, ferner umfassend eine Kopfschiene (3) an
einer zweiten Kante des Abdeckelements gegenü-
ber der unteren Schiene (7) und wobei sowohl der
erste als auch der sekundäre Einziehmechanismus
(23, 25) mit der Kopfschiene (3) in Verbindung sind. 10
 4. Einziehbare Abdeckvorrichtung nach Anspruch 3,
wobei die untere Schiene (7) mit mindestens einem
Führungselement (21) bereitgestellt ist und wobei
das mindestens eine flexible Element (19) um das
mindestens eine Führungselement (21) geschlun-
gen ist, um einen ersten Zweig (19A), der sich von
der Kopfschiene (3) zu dem mindestens einen Füh-
rungselement (21) erstreckt, und einen zweiten
Zweig (19B) zu definieren, der sich von dem min-
destens einen Führungselement (21) zu der Kopf-
schiene (3) und parallel zu dem ersten Zweig (19A)
des mindestens einen flexiblen Elements (19) er-
streckt. 15
 5. Einziehbare Abdeckvorrichtung nach einem der An-
sprüche 1 bis 4, wobei der sekundäre Einziehme-
chanismus (25) einen Federantrieb beinhaltet. 20
 6. Einziehbare Abdeckvorrichtung nach einem der An-
sprüche 1 bis 5, wobei das mindestens eine flexible
Element (19) ein Anhebeband ist und das Einziehen
des Abdeckelements durch Anheben der unteren
Schiene (7) erreicht werden kann. 25
 7. Einziehbare Abdeckvorrichtung nach einem der An-
sprüche 1 bis 6, wobei der primäre Einziehmecha-
nismus (23) eine erste Drehachse hat und der sek-
undäre Einziehmechanismus (25) eine zweite
Drehachse hat und wobei die zweite Drehachse par-
allel zu der ersten Drehachse ist. 30
 8. Einziehbare Abdeckvorrichtung nach Anspruch 7,
wobei eine erste Ebene definiert ist, die üblich für
die erste und zweite Drehachse ist, wobei die erste
Ebene senkrecht zu einer zweiten Ebene ist, die üb-
lich für die Kopf- (3) und untere (7) Schiene in einer
erweiterten Position des zusammenlegbaren Ab-
deckelements ist. 35
 9. Einziehbare Abdeckvorrichtung nach Anspruch 8,

wobei sich das mindestens eine flexible Element (19)
in einer dritten Ebene erstreckt, die die erste Ebene,
die üblich für die erste und zweite Drehachse ist, im
Wesentlichen zwischen der ersten und zweiten
Drehachse schneidet.

10. Einziehbare Abdeckvorrichtung nach Anspruch 9,
wobei die dritte Ebene koextensiv mit der zweiten
Ebene ist und wobei das mindestens eine flexible
Element (19) von dem primären Einziehmecha-
nismus (23) zu der zweiten Ebene durch ein erstes Füh-
rungsmittel und von dem sekundären Einziehme-
chanismus (25) zu der zweiten Ebene durch ein
zweites Führungsmittel umgelenkt wird. 40
11. Einziehbare Abdeckvorrichtung nach Anspruch 10,
wobei das erste Führungsmittel ein Umlenkstift (49,
51) ist und wobei das zweite Führungsmittel eine
Führungsrolle (45, 47) ist. 45

Revendications

1. Dispositif de revêtement rétractable pour ouvertures
architecturales, incluant :

un élément de revêtement pliable,
une barre inférieure (7), positionnée le long d'un
premier bord de l'élément de revêtement
pliable ;
au moins un élément flexible (19) en engage-
ment avec la barre inférieure (7) pour élever la
barre inférieure (7) et replier l'élément de revê-
tement pour définir une position rétractée du
revêtement ;
un mécanisme de rétraction primaire (23) pour
rétracter l'au moins un élément flexible (19)
d'une première extrémité de l'au moins un élé-
ment flexible (19) ; et
un mécanisme de rétraction secondaire (25)
connecté fonctionnellement à la barre inférieure
(7) ;
dans lequel le mécanisme de rétraction principal
(23) comprend au moins une bobine d'enroule-
ment primaire rotative (55) à laquelle une pre-
mière extrémité de l'au moins un élément flexi-
ble (19) est fixée, la première extrémité de l'élé-
ment flexible (19) étant enroulée ou déroulé sur
ou à partir de l'au moins une bobine d'enroule-
ment primaire rotative ;
dans lequel le mécanisme de rétraction secon-
daire (25) comprend au moins une bobine d'en-
roulement secondaire rotative (33) ;
par lequel le mécanisme de rétraction principal
(23) est configuré pour rétracter l'élément de re-
vêtement lors de la rétraction de l'au moins un
élément flexible (19) de la première extrémité
de l'au moins un élément flexible (19) ; 50

- et par lequel le mécanisme de rétraction principal (23) est indépendant du mécanisme de rétraction secondaire (25) ;
- caractérisé en ce que** le mécanisme de rétraction secondaire (25) est agencé pour rétracter l'au moins un élément flexible (19) d'une seconde extrémité de l'au moins un élément flexible (19) ;
- en ce que** la seconde extrémité de l'au moins un élément flexible (19) est fixée à l'au moins une bobine d'enroulement secondaire rotative (33) ; et **en ce que** le mécanisme de rétraction secondaire (25) est configuré pour rétracter sélectivement également l'élément de revêtement lors de la rétraction de l'au moins un élément flexible (19) de la seconde extrémité de l'au moins un élément flexible (19).
2. Dispositif de revêtement rétractable selon la revendication 1, dans lequel l'élément de couverture pliable comprend une pluralité de lattes allongées (5), maintenues dans un arrangement mutuellement parallèle et espacé par au moins deux échelles de suspension flexibles (9), qui sont espacées l'une de l'autre le long des lattes (5).
 3. Dispositif de revêtement rétractable selon la revendication 1 ou 2, comprenant en outre un rail de tête (3) sur un second bord de l'élément de revêtement opposé au rail inférieur (7), et dans lequel les premier et second mécanismes de rétraction (23, 25) sont associés au rail de tête (3).
 4. Dispositif de revêtement rétractable selon la revendication 3, dans lequel le rail inférieur (7) est pourvu d'au moins un élément de guidage (21) et dans lequel l'au moins un élément flexible (19) est bouclé autour de l'au moins un élément de guidage (21) pour définir une première branche (19A) s'étendant du rail de tête (3) à l'au moins un élément de guidage (21) et une seconde branche (19B) s'étendant de l'au moins un élément de guidage (21) au rail de tête (3) et parallèle à la première branche (19A) de l'au moins un élément flexible (19).
 5. Dispositif de revêtement rétractable selon l'une des revendications 1 à 4, dans lequel le mécanisme de rétraction secondaire (25) comprend un moteur à ressort.
 6. Dispositif de revêtement rétractable selon l'une des revendications 1 à 5, dans lequel l'au moins un élément flexible (19) est un ruban de levage et la rétraction de l'élément de couverture peut être effectuée en soulevant le rail inférieur (7).
 7. Dispositif de revêtement rétractable selon l'une des revendications 1 à 6, dans lequel le mécanisme de rétraction primaire (23) a un premier axe de rotation et le mécanisme de rétraction secondaire (25) a un second axe de rotation et dans lequel le second axe de rotation est parallèle au premier axe de rotation.
 8. Dispositif de revêtement rétractable selon la revendication 7, dans lequel un premier plan est défini qui est commun aux premier et second axes de rotation, lequel premier plan est perpendiculaire à un deuxième plan qui est commun aux rails de tête (3) et de fond (7) dans une position déployée de l'élément de revêtement pliable.
 9. Dispositif de revêtement rétractable selon la revendication 8, dans lequel l'au moins un élément flexible (19) s'étend dans un troisième plan qui coupe le premier plan commun aux premier et second axes de rotation sensiblement entre les premier et second axes de rotation.
 10. Dispositif de revêtement rétractable selon la revendication 9, dans lequel le troisième plan est coextensif avec le second plan et dans lequel l'au moins un élément flexible (19) est dévié du mécanisme de rétraction primaire (23) vers le second plan par un premier moyen de guidage et du mécanisme de rétraction secondaire (25) vers le second plan par un second moyen de guidage.
 11. Dispositif de revêtement rétractable selon la revendication 10, dans lequel le premier moyen de guidage est une broche de déviation (49, 51) et dans lequel le second moyen de guidage est un rouleau de guidage (45, 47).

Fig.1.

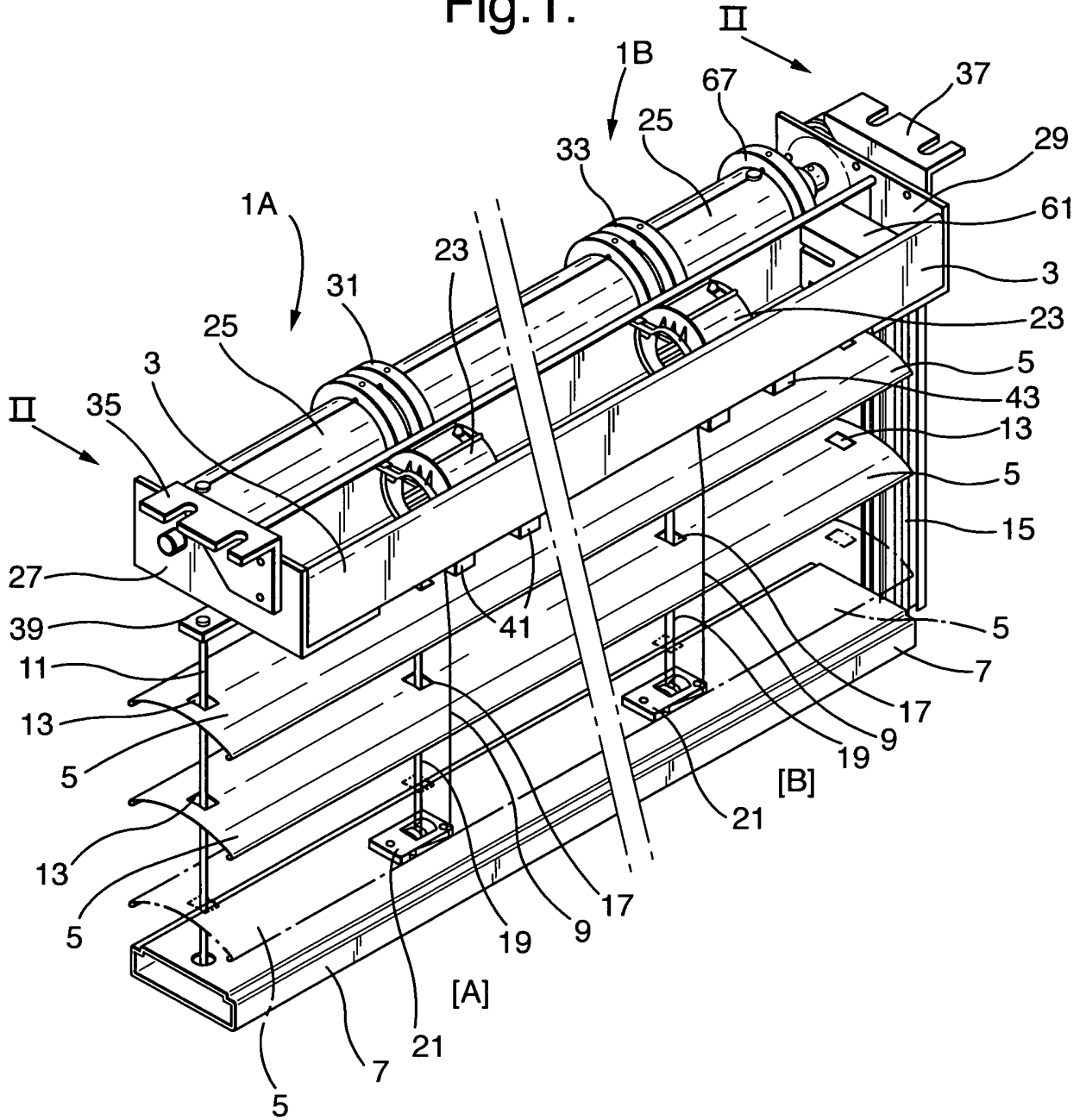

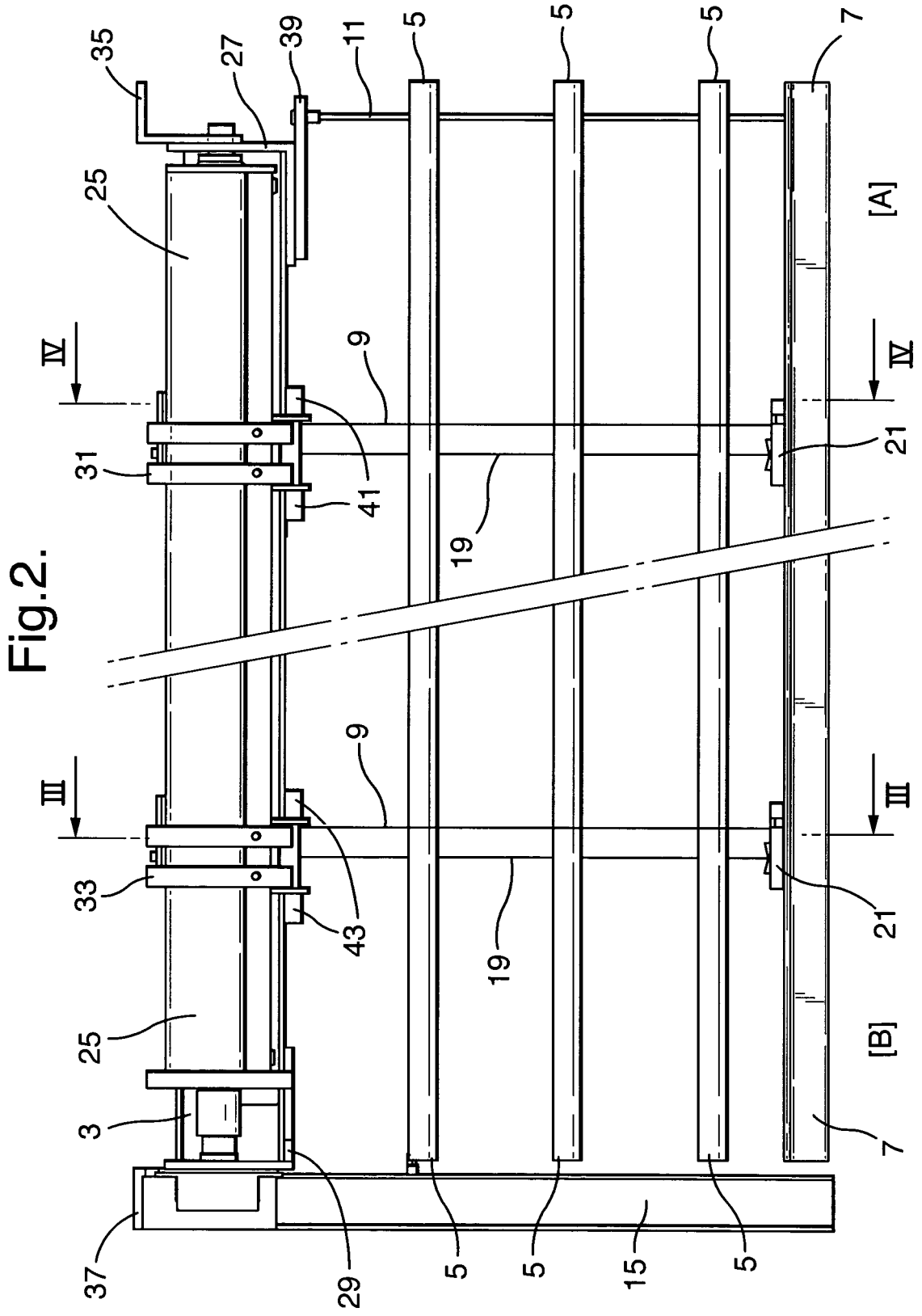
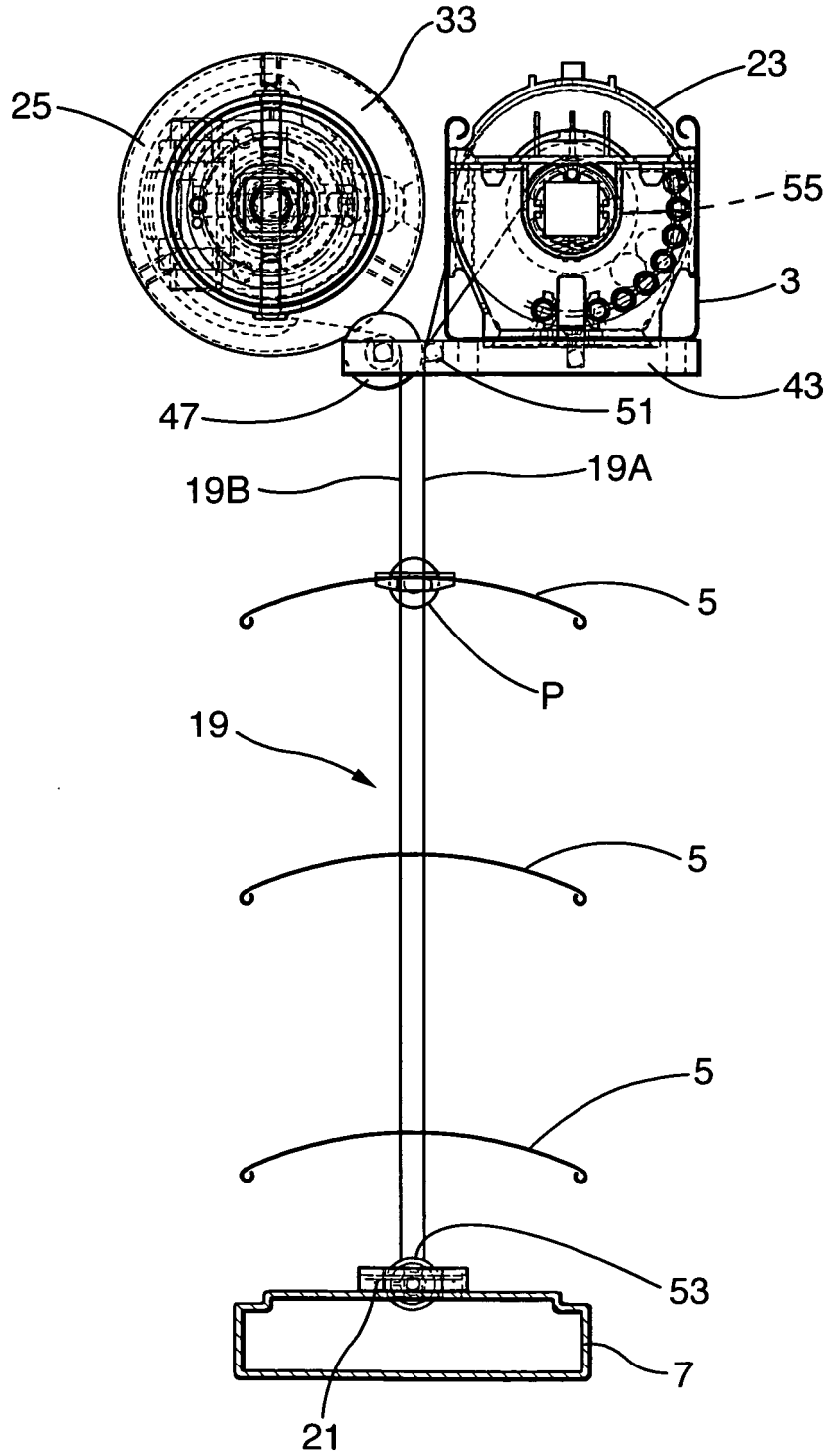

Fig.3.



REFERENCES CITED IN THE DESCRIPTION

This list of references cited by the applicant is for the reader's convenience only. It does not form part of the European patent document. Even though great care has been taken in compiling the references, errors or omissions cannot be excluded and the EPO disclaims all liability in this regard.

Patent documents cited in the description

- DE 3238473 [0002]
- EP 1681435 A [0002]
- US 3279528 A [0002]