

(19) World Intellectual Property Organization
International Bureau



(43) International Publication Date
25 June 2009 (25.06.2009)

PCT

(10) International Publication Number
WO 2009/078630 A1

- (51) International Patent Classification:
H01Q 13/02 (2006.01) H01Q 21/00 (2006.01)
- (21) International Application Number:
PCT/KR2008/007392
- (22) International Filing Date:
12 December 2008 (12.12.2008)
- (25) Filing Language: Korean
- (26) Publication Language: English
- (30) Priority Data:
10-2007-0130952 14 December 2007 (14.12.2007) KR
10-2008-0054854 11 June 2008 (11.06.2008) KR
10-2008-0080536 18 August 2008 (18.08.2008) KR
10-2008-0080539 18 August 2008 (18.08.2008) KR
- (71) Applicant (for all designated States except US): **IDOIT CO., LTD.** [KR/KR]; 1308 Woolim Lions 2-cha, Gasan-dong, Guemcheon-gu, Seoul 153-787 (KR).
- (72) Inventors; and
- (75) Inventors/Applicants (for US only): **IM, Seung joon** [KR/KR]; 1308 Woolim Lions 2-cha, Gasan-dong, Guemcheon-gu, Seoul 153-787 (KR). **RYU, Chang wan** [KR/KR]; 127-1403 Hanbit Apt., Eoeun-dong, Yuseong-gu, Daejeon 305-755 (KR). **KO, Jae Ho** [KR/KR]; 1301 Omokyo Byucksan Blooming Apt., 39-1 Yangpyeong-dong 2(i)-ga, Yeongdeungpo-gu, Seoul 150-102 (KR).
- (74) Agent: **KIM, Dong jin**; 301, 3F Gangnam Metro Bldg., 1339-9 Seocho-dong, Seocho-gu, Seoul 137-860 (KR).
- (81) Designated States (unless otherwise indicated, for every kind of national protection available): AE, AG, AL, AM, AO, AT, AU, AZ, BA, BB, BG, BH, BR, BW, BY, BZ, CA, CH, CN, CO, CR, CU, CZ, DE, DK, DM, DO, DZ, EC, EE, EG, ES, FI, GB, GD, GE, GH, GM, GT, HN, HR, HU, ID, IL, IN, IS, JP, KE, KG, KM, KN, KP, KZ, LA, LC, LK, LR, LS, LT, LU, LY, MA, MD, ME, MG, MK, MN, MW, MX, MY, MZ, NA, NG, NI, NO, NZ, OM, PG, PH, PL, PT, RO,

[Continued on next page]

(54) Title: HORN ARRAY TYPE ANTENNA WITH SKEW FILTER

[Fig. 33]

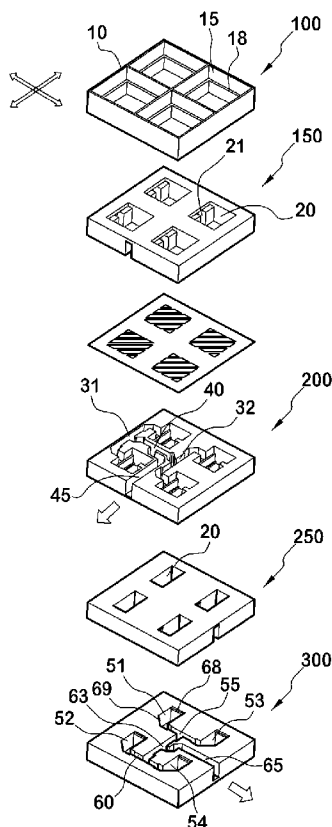

(57) Abstract: A horn array antenna has a skew filter mounted thereon. By having a skew filter, the antenna is capable of maintaining the transmission and reception rate easily even when the electromagnetic waves have inclined direction of vibration.

WO 2009/078630 A1



RS, RU, SC, SD, SE, SG, SK, SL, SM, ST, SV, SY, TJ, TM,
TN, TR, TT, TZ, UA, UG, US, UZ, VC, VN, ZA, ZM, ZW.

NO, PL, PT, RO, SE, SI, SK, TR), OAPI (BF, BJ, CF, CG,
CI, CM, GA, GN, GQ, GW, ML, MR, NE, SN, TD, TG).

(84) Designated States (*unless otherwise indicated, for every kind of regional protection available*): ARIPO (BW, GH, GM, KE, LS, MW, MZ, NA, SD, SL, SZ, TZ, UG, ZM, ZW), Eurasian (AM, AZ, BY, KG, KZ, MD, RU, TJ, TM), European (AT, BE, BG, CH, CY, CZ, DE, DK, EE, ES, FI, FR, GB, GR, HR, HU, IE, IS, IT, LT, LU, LV, MC, MT, NL,

Published:

- *with international search report*
- *before the expiration of the time limit for amending the claims and to be republished in the event of receipt of amendments*

Description

HORN ARRAY TYPE ANTENNA WITH SKEW FILTER

Technical Field

- [1] The present invention relates to a horn array type antenna with skew filter, and more particularly, a horn array type antenna with skew filter for improving an antenna performance and reducing a size of antenna.

Background Art

- [2] Waves with frequencies above the ultra high frequency (UHF) band have very short wavelengths and similar characteristics to those of light. A linear polarization antenna has been developed and applied to transmit and receive such waves above UHF band more effectively, based on a combination of optics theory and a theory that a magaphone concentrates sound waves.
- [3] Meanwhile, electric field has a vibrating direction which slightly varies depending on the locations. A linear polarization antenna is particularly sensitive to the vibrating direction of electric field for transmission or reception, and thus can have considerably deteriorated transmission efficiency in certain locations.

Disclosure of Invention

Technical Problem

- [4] Therefore, an object of the present invention is to provide a horn array antenna having an improved antenna performance and a small size.
- [5] Another object of the present invention is to provide a horn array antenna having a skew filter capable of changing the directivity of the polarization wave, which is inappropriate for an antenna to receive, toward appropriate direction.

Technical Solution

- [6] In order to achieve the objects of the present invention, a horn array antenna for dual linear polarization for receiving a first polarization and a second polarization is provided, which includes a plurality of horns to which the first and second polarizations enter together, a plurality of polarization filtering units provided to the horns, to separate the first and second polarizations from the mixture of the first and second polarizations entering the horns, a first polarization guide to guide the first polarization which is separated at the polarization filtering units, and a second polarization guide to guide the second polarization which is separated at the polarization filtering units. The first polarization guide includes a first guide unit to receive the first polarization through one and the other ends thereof, the first polarization received having been separated at the first and second polarization filtering units, a second guide unit to receive the first polarization through one and the other ends thereof, the

first polarization received having been separated at the third and fourth polarization filtering units, a first relay unit to connect a portion of the first guide unit with a portion of the second guide unit, and mix the first polarization provided from the first and second guide units, and a first mixing unit connected to a portion of the first relay unit, to receive the first polarization mixed at the first relay unit.

- [7] According to an aspect of the present invention, a horn array antenna for dual linear polarization for receiving a first polarization and a second polarization, includes a plurality of horns to which the first and second polarizations enter together, a plurality of polarization filtering units provided to the horns, to separate the first and second polarizations from the mixture of the first and second polarizations entering the horns, a first polarization guide to guide the first polarization which is separated at the polarization filtering units, and a second polarization guide to guide the second polarization which is separated at the polarization filtering units. The second polarization guide includes a first direction changing unit to change an advancing direction of the second polarization provided from the first polarization filtering unit, a second direction changing unit to change an advancing direction of the second polarization provided from the second polarization filtering unit, a third direction changing unit to change an advancing direction of the second polarization provided from the third polarization filtering unit, a fourth direction changing unit to change an advancing direction of the second polarization provided from the fourth polarization filtering unit, a first guide unit to connect the first and third direction changing units, and mix the second polarization provided from the first and third direction changing units, a second guide unit to connect the second and fourth direction changing units, and mix the second polarization provided from the second and fourth direction changing units, a first relay unit to connect a portion of the first guide unit with a portion of the second guide unit, and mix the second polarization provided from the first and second guide units, and a first mixing unit connected to a portion of the first relay unit, to guide so that the second polarization provided from the first relay unit is emerged.

- [8] According to another aspect of the present invention, a horn array antenna for dual linear polarization for receiving a first polarization and a second polarization, includes a plurality of horns to which the first and second polarizations enter together, a plurality of polarization filtering units to separate the first and second polarizations from the mixture of the first and second polarizations entering the horns, a first polarization guide to guide the first polarization which is separated at the polarization filtering units, and a second polarization guide to guide the second polarization which is separated at the polarization filtering units. An upper portion of the polarization filtering unit is in a square box shape, and a lower portion of the polarization filtering unit is in a narrower square box shape.

[9] According to yet another aspect of the present invention, a horn array antenna for dual linear polarization for receiving a first polarization and a second polarization, includes a plurality of horns to which the first and second polarizations enter together, a plurality of polarization filtering units to separate the first and second polarizations from the mixture of the first and second polarizations entering the horns, a first polarization guide to guide the first polarization which is separated at the polarization filtering units, a second polarization guide to guide the second polarization which is separated at the polarization filtering units, and a skew filter to change an angle of at least one of the first and second polarizations.

[10] According to yet another aspect of the present invention, a horn array antenna includes a plurality of horns to which electromagnetic waves enter, a guide to guide the electromagnetic waves entering into the horns, and a skew filter to change an angle of the electromagnetic waves.

Advantageous Effects

[11] According to an embodiment of the present invention, an antenna provides improved performance and reduced size.

[12] Furthermore, a skew filter is applicable to the horn array antenna to change a direction of electric field of the polarization to an appropriate direction, if the polarization has a direction of electric field inappropriate for the antenna to receive. As a result, the antenna has improved receptivity.

Brief Description of Drawings

[13] Fig. 1 is an exploded perspective view of each layer of horn array antenna for dual linear polarization according to the present invention;

[14] Fig. 2 is a plan view of the second layer of Fig. 1;

[15] Fig. 3 is a perspective view of the second layer;

[16] Fig. 4 is a rear view of the second layer;

[17] Fig. 5 is a plan view of the third layer of Fig. 1;

[18] Fig. 6 is a perspective view of the third layer;

[19] Fig. 7 is a rear view of the third layer;

[20] Fig. 8 is a plan view of the fourth layer of Fig. 1;

[21] Fig. 9 is a perspective view of the fourth layer;

[22] Fig. 10 is a rear view of the fourth layer;

[23] Fig. 11 is a plan view of the fifth layer;

[24] Fig. 12 is a perspective view of the fifth layer;

[25] Fig. 13 is a perspective view of an embodiment of antenna according to the invention;

[26] Fig. 14 is a perspective view of the first layer;

- [27] Fig. 15 is a plan view of the second layer;
- [28] Fig. 16 is a perspective view of the second layer;
- [29] Fig. 17 is a rear view of the second layer;
- [30] Fig. 18 is a plan view of the third layer of antenna of Fig. 13;
- [31] Fig. 19 is a perspective view of the third layer;
- [32] Fig. 20 is a rear view of the third layer;
- [33] Fig. 21 is a plan view of the fourth layer of Fig. 14;
- [34] Fig. 22 is a perspective view of the fourth layer;
- [35] Fig. 23 is a rear view of the fourth layer;
- [36] Fig. 24 is a front view of the fifth layer of Fig. 13;
- [37] Fig. 25 is a perspective view of the fifth layer;
- [38] Figs. 26 to 28 are views provided to explain the concept of a skew filter;
- [39] Figs. 29 to 36 illustrate a method for applying a skew filter to the horn array antenna for dual linear polarization according to embodiments of the present invention;
- [40] Figs. 37 to 41 are views illustrating the variations of the skew filter;
- [41] Figs. 42 to 44 illustrate skew filters whose ends are not in contact with the edges of the inner opening;
- [42] Fig. 45 is a view illustrating an example of employing a skew filter when the horn is not parallel with the polarization filtering unit;
- [43] Figs. 46 and 47 are views illustrating examples of a spacer;
- [44] Fig. 48 is a perspective view of a horn array antenna for single linear polarization applicable to the embodiments of the present invention;
- [45] Fig. 49 is an exploded perspective view illustrating the layers of the horn array antenna of Fig. 48;
- [46] Fig. 50 is a perspective view of the first layer;
- [47] Fig. 51 is a plan view of the first layer viewed from above;
- [48] Fig. 52 is a rear view of the first layer viewed from under;
- [49] Fig. 53 is a perspective view of the second layer;
- [50] Fig. 54 is a plan view of the second layer viewed from above;
- [51] Fig. 55 is a rear view of the second layer viewed from under;
- [52] Fig. 56 is a perspective view of the third layer;
- [53] Fig. 57 is a plan view of the third layer viewed from above;
- [54] Fig. 58 is a rear view of the third layer viewed from under;
- [55] Figs. 59 to 61 are views provided to explain concept of a skew filter;
- [56] Figs. 62 to 65 are views illustrating a method for applying a skew filter to the horn array antenna for single linear polarization according to embodiments of the present invention;
- [57] Fig. 66 is a graphical representation showing movement of a main beam center

according to skew filter;

- [58] Fig. 67 is a view illustrating an example where a skew filter is applied;
- [59] Fig. 68 is a view illustrating an angle of a skew filter;
- [60] Fig. 69 is a view illustrating the simulation result obtained at an angle of 0°;
- [61] Fig. 70 is a view illustrating the simulation result obtained at an angle of 15°;
- [62] Fig. 71 is a view illustrating the simulation result obtained at an angle of 30°;
- [63] Fig. 72 is a view illustrating the simulation result obtained at an angle of 45°; and
- [64] Fig. 73 is a view illustrating the simulation result obtained at an angle of 75°.

Best Mode for Carrying out the Invention

- [65] The embodiments of the present invention will be explained below with reference to the accompanying drawings.

- [66] While an antenna according to an embodiment of the present invention is capable of both transmitting and receiving electromagnetic waves, for the purpose of convenience of explanation, the description of the antenna will be first focused on the components operating on a reception mode, and explanation of the antenna on the electromagnetic wave transmission mode will follow.

- [67] According to an embodiment of the present invention, a first polarization (horizontal polarization: H polarization) is horizontal to the equator of the earth, and a second polarization (vertical polarization: V polarization) is vertical to the equator of the earth.

- [68] According to an embodiment of the present invention, an antenna is provided with a filter, and may include, for example, a horn array antenna for dual linear polarization or single linear polarization.

- [69] In other words, the horn array antenna for dual linear polarization is capable of receiving two linear polarizations, and the horn array antenna for single linear polarization is capable of receiving one linear polarization.

- [70] According to an embodiment of the present invention, a horn array antenna for dual linear polarization such as the ones disclosed in Korean Patent Application No. 10-2007-001683 entitled 'Horn array antenna for dual linear polarization', and Korean Patent Application No. 10-2007-70021929 entitled 'Horn array antenna for dual linear polarization', is applicable, the disclosure of which is incorporated herein by reference. One will understand that the horn array antennas for dual linear polarization disclosed in the abovementioned applications are only examples and therefore, should not be construed as limiting. Accordingly, a horn array antenna for dual linear polarization with different structure may be applied according to an embodiment of the present invention. Basically, an antenna, which is capable of separating two polarizations and transmitting or receiving the polarizations, can be used according to an embodiment of the present invention.

[71] Hereinbelow, a horn array antenna for dual linear polarization applicable in an embodiment of the present invention will be explained.

[72] Fig. 1 is an exploded perspective view of each layer of horn array antenna unit for dual linear polarization according to the present invention. The term 'antenna unit' herein refers to an antenna composed of four horns, and even when the horn array antenna includes more than one antenna unit, all the antenna units have the identical operations. Accordingly, the operation of the horn array antenna will be explained below on the basis of one antenna unit for the purpose of convenience of explanation.

[73] The horn array antenna for dual linear polarization according to an embodiment of the present invention includes a first layer 100, a second layer 150, a third layer 200, a fourth layer 250, and a fifth layer 300.

[74] The first layer 100 is capable of receiving external polarizations. The horn 10 of the first layer 100 is formed in square shape, and thus is capable of receiving two orthogonal polarizations. According to an embodiment of the present invention, the first layer 100 includes an inclined portion 15 and a protrusion 18, and also an inner opening. However, elements such as inclined portion or protrusion are only for illustrative examples, and therefore, other adequate examples may also be applied.

[75] Fig. 2 is a plan view of the second layer of Fig. 1, Fig. 3 is a perspective view of the second layer, and Fig. 4 is a rear view of the second layer.

[76] The second layer 150 includes a polarization filtering unit 20 connected with the inner opening of the first layer 100, and the polarization filtering unit 20 is passed through the areas adjacent to the respective corners of the second layer 100. The polarization filtering unit 200 includes a first polarization introducing path 21, and an interference protrusion 19.

[77] On a rear side of the second layer 150 is formed an upper portion of the first polarization guide 30, that is, upper portions of the first and second guide tubes 31, 32, the first relay tube 40, and the first mixing tube 45 are formed on a rear side of the second layer 150.

[78] Fig. 5 is a plan view of the third layer of Fig. 1, Fig. 6 is a perspective view of the third layer, and Fig. 7 is a rear view of the third layer.

[79] A lower portion of the first polarization guide 30 is formed on an upper side of the third layer 200, and only the polarization filtering unit 20 is passed through the lower side of the third layer 200. Lower portions of the first and second guide tubes 31, 32, the first relay tube 40, and the first mixing tube 45 of the first polarization guide 30 are formed on the upper side of the third layer 200.

[80] As explained above, the rear side of the second layer and the upper side of the third layer form the first polarization guide unit. Referring to Fig. 3, the first polarization is introduced into the first polarization introducing path 21, and guided along the guide.

Referring to Figs. 4 and 5, on entering the introducing path 21, the polarizations pass in sequence the first and second guide tubes 31, 32, the first relay tube 40, and the first mixing tube 45, and so are mixed with each other (the polarizations are separated from each other in these tubes during antenna radiation).

[81] Fig. 8 is a plan view of the fourth layer of Fig. 1, Fig. 9 is a perspective view of the fourth layer, and Fig. 10 is a rear view of the fourth layer.

[82] Only the polarization filtering unit 20 is passed through the upper side of the fourth layer 250, and upper portions of the first to fourth direction changing units 51, 52, 53, 54, the third and fourth guide tubes 55, 60, the second relay tube 63, and the second mixing tube 65 are formed on the lower side of the fourth layer 250.

[83] Fig. 11 is a plan view of the fifth layer, and Fig. 12 is a perspective view of the fifth layer.

[84] The lower portion of the second polarization guide 50 is formed on the upper side of the fifth layer 300. The fifth layer 300 forms the second polarization guide 50 in cooperation with the fourth layer 250, and the first to fourth direction changing units 51, 52, 53, 54, the third and fourth guide tubes 55, 60, the second relay tube 63, and the second mixing tube 65 are formed on the fifth layer 300. According to an embodiment of the present invention, each of the first to fourth direction changing units 51, 52, 53, 54 includes a protrusion 68 and a reflecting surface 69 therein, but one will understand that these elements are only for illustrative examples, and should not be construed as limiting.

[85] Likewise, the rear side of the fourth layer and the upper side of the fifth layer form a second polarization guide. Referring to Figs. 10 and 11, the second polarization is introduced into the first to fourth direction changing units 51, 52, 53, 54, and mixed with each other as it is passed through the third and fourth guide tubes 55, 60, the second relay tube 63, and the second mixing tube 65 in sequence.

[86] While the embodiment explained above takes an example where there are five layers, one will understand that this is only one of various applicable examples, and therefore, an antenna unit may have less or more than five layers.

[87] A horn array antenna for dual linear polarization according to an embodiment of the present invention will now be explained below, with reference to an example where the horn array antenna includes 32 antenna units.

[88] Fig. 13 is a perspective view of an embodiment of antenna according to the invention, Fig. 14 is a perspective view of the first layer, Fig. 15 is a plan view of the second layer, Fig. 16 is a perspective view of the second layer, and Fig. 17 is a rear view of the second layer.

[89] Fig. 13 shows an antenna having a plurality of layers, namely, a first, second, third, fourth and fifth layers according to an embodiment of the present invention. More

specifically, the rear side of the first layer is combined with the planar side of the second layer, the rear side of the second layer is combined with the planar side of the third layer, the rear side of the third layer is combined with the planar side of the fourth layer, and the rear side of the fourth layer is combined with the planar side of the fifth layer. The layers are combined with each other, thereby forming passages to guide the polarizations, while the rear side of the second layer and the planar side of the third layer are combined with each other to form a first polarization guide, and the rear side of the fourth layer and the planar side of the fifth layer are combined with each other to form a second polarization guide.

[90] An antenna according to an example of the present invention will be explained below with reference to each of the layers.

[91] Fig. 18 is a plan view of the third layer of antenna of Fig. 13, Fig. 19 is a perspective view of the third layer, and Fig. 20 is a rear view of the third layer.

[92] In an antenna 1 according to an embodiment of the present invention, the rear side of the second layer 150 and the planar side of the third layer 200 form the first polarization guide.

[93] The rear side of the second layer 150, and the planar side of the third layer 300 are in symmetry with each other, and when combined with each other, form a space to guide the waves. The process of guiding the first polarization will be explained below based on the plan view of the third layer 300 illustrated in Fig. 18.

[94] Once separated in the polarization separating portion, the first polarization is introduced into the antenna introducing path 21. With respect to the antenna unit 325, the first polarizations from the four horns are mixed at the antenna unit 325, and the first polarization from the antenna unit 325 is mixed with the first polarization from the antenna unit 326 at reference numeral 367. At reference numeral 366, the first polarizations from the antenna units 325, 326, 317, 318 are mixed. In the manner explained above, the first polarizations are mixed with each other, and eventually, all the first polarizations are mixed at reference numeral 381. Once all the first polarizations are mixed, the first polarizations move toward the first polarization input/output hole 400. Note that the above refers to an example where the antenna receives electromagnetic waves. Accordingly, if the antenna is operating to radiate electromagnetic waves, the first polarization is passed through the input/output hole 400, and separated as it is passed in a reverse sequence, and as a result, each of the separated first polarizations is moved toward the horn to be radiated. The first polarization input/output hole 400 is passed through the third, fourth and fifth layers as illustrated in Figs. 20, 21, 22, 23, 24, 25 and 28.

[95] However, the abovementioned passages of the first polarization guide are only an example, and therefore, other types of examples may also be applied. For example,

various forms of tubes to collect the filtered first polarizations from the filtering unit, may be used as the constituents of the first polarization guide.

- [96] The second polarization guide formed by the rear side of the fourth layer and the upper side of the fifth layer will now be explained below with reference to Figs. 23 and 24.
- [97] The rear side of the fourth layer and the upper side of the fifth layer are in symmetry with each other, and combined with each other to guide the electromagnetic waves, that is, to guide the second polarization in particular. The process of guiding the second polarization will be explained below based on the plan view of the fifth layer 300 illustrated in Fig. 24.
- [98] The second polarization is separated in the polarization separating unit and introduced into the direction changing unit. With respect to the antenna unit 525, the second polarizations from the four horns are mixed at the antenna unit 525, and the second polarization from the antenna unit 525 and the second polarization from the antenna unit 517 are mixed with each other at reference numeral 569. At reference numeral 570, the second polarizations from the antenna units 525, 517, 526, 518 are mixed with each other. Accordingly, the second polarizations are mixed in the above-explained manner, and eventually, all the second polarizations are mixed at reference numeral 581. Once all the second polarizations are mixed, the second polarizations are moved toward the second polarization input/output hole 600. Note that the above refers to an example where the antenna receives electromagnetic waves. Accordingly, if the antenna is operating to radiate electromagnetic waves, the second polarization is passed through the second polarization input/output hole 600, and separated as it is passed in a reverse sequence, and each of the separated second polarizations is moved toward the horn to be radiated. The second polarization input/output hole 600 is passed through the fifth layer as illustrated in Figs. 24 and 26.
- [99] Note that the tubes of the second polarization guide are only examples, and that other forms of example are also applicable. For example, various forms of tubes to filter the second polarizations filtered at the filtering unit, may be used as the constituents of the second polarization guide.
- [100] While the first and second polarizations are explained with respect to the magnetic field in the embodiments explained above, one will understand that the embodiments of the present invention are also applicable to the magnetic field. Additionally, although the embodiments explained above exemplified the constitution including the horn 10, the first polarization guide 30 and the second polarization guide 50, this is also an example. Accordingly, other adequate examples are applicable. For example, when necessary, at least two from among the horn 10, the first polarization guide 30, and the second polarization guide 50 may be fabricated integrally using method such as

injection molding. Additionally, in fabricating the horn 10, the first polarization guide 30 and the second polarization guide 50 according to an embodiment of the present invention, the number of layers is not limited to the example illustrated in Figs. 2 to 24.

[101] Additionally, although the horn array antenna for dual linear polarization has been mainly explained in the above embodiments, one will understand that the horn array antenna for single linear polarization is equally applicable. Any type of antenna is applicable according to the present invention. For example, a single or dual planar horn array type, or a slot antenna type may also be used. Any antenna other than horn array or slot antenna type is also applicable if the antenna is structured to receive and separate two orthogonal polarizations.

[102] Meanwhile, the direction of electric field of the second polarization being introduced, has to be parallel to the lower shorter side of the polarization filtering unit 20 (see Fig. 26) in order to increase the reception rate at the horn array antenna for dual linear polarization explained above. Referring to Fig. 27, if the direction of the electric field of the second polarization being introduced is not parallel, but skewed to the lower shorter side of the polarization filtering unit 20, the horn array antenna for dual linear polarization has a poor reception rate of the second polarization.

[103] However, even if the direction of the electric field of the second polarization being introduced is not parallel, but skewed to the lower shorter side of the polarization filtering unit 20, the horn array antenna for dual linear polarization can have a high reception rate, if the antenna is provided with a comb-like skew filter (see Fig. 28). The skew filters according to the embodiments of the present invention, such as the skew filter provided on the upper portion of the horn array antenna for dual linear polarization (see Fig. 30), the skew filter provided inside the horn array antenna for dual linear polarization (see Figs. 31, 33, 35), the skew filter provided on the upper portion of the horn array antenna for single linear polarization (see Fig. 106), or the skew filter provided inside the horn array antenna for single linear polarization (see Fig. 104), have been proven to increase the reception rate of the polarizations which are introduced in oblique course.

[104] The teeth of the comb-like skew filter are formed at a predetermined angle with respect to the vibrating direction of the electric field of the second polarization being introduced. For example, the predetermined angle may be 90° . However, the angle of 90° is only an example, and accordingly, more or less than 90° may be adaptively applied depending on the given transmission and reception environment.

[105] Meanwhile, the angle of incidence of the second polarization is different depending on the location (latitude and longitude) of the area where the horn array antenna 1 is used, and this means that the angle of incidence of the second polarization can be computed based on the latitude and longitude of the location to receive the second po-

larization. Accordingly, based on the latitude and longitude of the area to receive the second polarization, the angle of teeth of the skew filter can be decided.

[106] The skew filter may be embodied using conductive materials such as copper, nickel, or iron, or alternatively, the skew filter may desirably be embodied by plating synthetic resin with an adequate conductive material. The skew filter may preferably have 0.03mm to 1mm of thickness, but this may vary as occasion demands.

[107] Figs. 29 to 31 illustrate a method for applying a skew filter to the horn array antenna for dual linear polarization according to embodiments of the present invention.

[108] Referring to Fig. 29, a skew filter provided as a film may be placed on the upper portion of the first layer 100. Secondly, referring to Fig. 30, a skew filter may be formed directly on the upper portion of the first layer 100.

[109] According to the abovementioned first and second methods, the skew filter is formed on the upper portion of the horns 10. The ends of the teeth of the skew filter are in contact with the edge of the outer opening of the horns 10.

[110] Thirdly, and referring to Fig. 31, a film type of skew filter may be inserted between the first and second layers 100, 150. Fourthly, and referring to Fig. 32, a skew filter may be formed directly on the upper portion of the second layer 150.

[111] According to the third and fourth methods explained above, the skew filter is formed on the lower side of the horns 10. The ends of the teeth of the skew filter are in contact with the lower edge of the horns 10.

[112] Meanwhile, a skew filter mounted according to the first to fourth methods was proven to increase transmission and reception rate even when the polarization is skewed.

[113] Referring to Fig. 33, the fifth method is to insert a film type skew filter in between the second and third layers 150, 200. Referring to Fig. 34, the sixth method is to form a skew filter directly on the upper portion of the third layer 200.

[114] According to the fifth and sixth methods explained above, the skew filter is formed in the center of the polarization filtering unit 20. The ends of the teeth of the skew filter are in contact with the walls of the polarization filtering unit 20.

[115] Referring to Fig. 35, the seventh method is to insert a film type skew filter in between the third and fourth layers 200, 250. Referring to Fig. 36, the eighth method is to form the skew filter directly on the upper portion of the fourth layer 250.

[116] According to the seventh and eighth methods explained above, the skew filter is formed on the lower portion of the polarization filtering unit 20. The ends of the teeth of the skew filter are in contact with the walls of the polarization filtering unit 20.

[117] The number of teeth of the skew is not limited, and therefore, one or more than one teeth may be formed as occasion demands. Furthermore, the width of the tooth, and the intervals between the teeth are not limited. The ends of the teeth may desirably be

rounded. Refer to Figs. 37 to 41 for variations of the skew filter.

- [118] It is possible that the ends of the teeth of the skew filter are not in contact with the horns 10 or polarization filtering units 20. The ends of the teeth may also be rounded. Figs. 42 to 44 illustrate skew filters whose ends are not in contact with the walls of the polarization filtering units 20. The skew filters illustrated have one tooth, but one will understand that two or more teeth may be employed.
- [119] Note that only the film type skew filter can have ends of the teeth that do not contact the polarization filtering units 20, and it is necessary to coat the skew filter as a thin layer of nonconductive material to fix the teeth in position.
- [120] The teeth of the skew filter may be formed in various manners other than the examples provided above.
- [121] In the horn array antenna 1 for dual linear polarization explained above according to the embodiments of the present invention, the polarization filtering units 10 are parallel to the horns 10 (that is, the sides of the polarization filtering units 20 are parallel to the sides of the horns 10). However, even when the polarization filtering units 20 and the horns 10 are not parallel, for example, even when the sides of the polarization filtering units 20 are at 45° with respect to the sides of the horns 10 (Fig. 45), it is still possible to employ the skew filter according to the embodiments of the present invention.
- [122] Furthermore, although the process of the horn array antenna for dual linear polarization receiving the polarization has been explained so far, one will understand that the same applies to the case of transmitting the polarization so that it is possible to use the skew filter to transmit the polarization having certain degrees of inclination.
- [123] Two overlaying skew filters may be used, and a spacer may be inserted between the horn array antenna and the skew filter or between the skew filters to provide a space there between.
- [124] The spacer may be made of, for example, paper, woodrock, or thin sponge plate. The spacer may not be made of a material that disturbs electric waves, since the spacer is inserted between the horn array antenna and the skew filter or between the skew filters to provide, for example, a few millimeters of space. For example, a material with high conductivity is not a good choice for the spacer.
- [125] The spacer may have a predetermined height (such as a few millimeters) as illustrated in Fig. 46 or Fig. 47, and be provided in a square configuration. The vertical and horizontal sides of the square may desirably correspond to the skew filter, but this is not limiting, since the spacer can have any structure if it provides a space between the skew filter and the horn array antenna for dual linear polarization.
- [126] Referring to Fig. 46, a spacer 441 is a square spacer to correspond to the structure of the skew filter. The spacer 44 does not necessarily have the same vertical and horizontal lengths as those of the skew filter, since the spacer is fully satisfactory if it

provides a space between the skew filter and the horn array antenna.

[127] Referring to Fig. 47, a spacer 443 is an empty square spacer. An additional structure such as the one similar to a window frame may be provided in the empty space of the spacer 443.

[128] The spacers explained above can be placed between the skew filter and the horn array antenna, or between the skew filters.

[129] Although the horn array antenna for dual linear polarization having a skew filter has been explained above, one will note that the skew filter can be fabricated separately.

[130] Herein below, a horn array antenna for single linear polarization applicable to the embodiments of the present invention will be explained in detail. Although the applicable horn array antenna for single linear polarization is capable of both transmitting and receiving the electromagnetic waves, for convenience of explanation, the operations of each component part of the horn array antenna will be focused mainly on the receiving end, and then the operations of the horn array antenna as a transmitting end will be explained in the later part of the description.

[131] The horn array antenna for single linear polarization is capable of transmitting or receiving both horizontal (H) and vertical (V) polarizations.

[132] Fig. 48 is a perspective view of a horn array antenna for single linear polarization applicable to the embodiments of the present invention, and Fig. 49 is an exploded perspective view illustrating the layers of the horn array antenna of Fig. 48.

[133] As shown, the horn array antenna 10 for single linear polarization includes three layers 310, 320, 330 overlain on one another. The horn array antenna 10 includes four horns 100 to which electromagnetic waves enter, and a guide 200 to form the electromagnetic waves into a single stream and outputs the electromagnetic waves.

[134] Each of the horns 100 is the place where an outer opening 110, an inclined portion 120, a protrusion 130, and an inner opening 140 are formed.

[135] The protrusion 130 extends inward from the outer side of the horn 100. Due to the presence of the protrusion 130, the area of the inner opening 140 is smaller than that of the outer opening 110.

[136] The inclined portion 120 is inclined inward at the outer side of the horn 100, with reference to the downward direction of the horn 100.

[137] While the outer opening 110 is square shape, the inner opening 140 is rectangular shape. Accordingly, two types of linear polarizations enter the outer opening 110, but only the linear polarization having the direction of electric field that is parallel to the shorter sides of the inner opening 140, can pass to enter the inner opening 140.

[138] The horn 100 is formed over the first and second layers 310, 320. Specifically, the upper portion of the horn 100 is formed on the first layer 310, while there is the lower portion of the horn 100 formed on the upper portion of the second layer 320. The upper

portion of the horn 100 corresponds to the outer opening 110 and the inclined portion 120, and the lower portion of the horn 100 corresponds to the protrusion 130 and the inner opening 140.

- [139] The guide 200 is formed over the second and third layers 320, 330. Specifically, an upper portion of the guide 200 is formed on the lower portion of the second layer 320, while there is the lower portion of the guide 200 formed on the third layer 330.
- [140] Fig. 50 is a perspective view of the first layer 310, Fig. 51 is a plan view of the first layer 310 viewed from above, and Fig. 52 is a rear view of the first layer 310 viewed from under.
- [141] As shown, the outer opening 110 of the horn 100 is formed on the planar side of the first layer 310. There also is an opening in the rear side of the first layer 310.
- [142] Due to the inclined portion 120 formed on the first layer 310, the area of the outer opening 110 formed on the planar side is larger than that of the opening formed on the rear side.
- [143] Fig. 53 is a perspective view of the second layer 320, Fig. 54 is a plan view of the second layer 320 viewed from above, and Fig. 55 is a rear view of the second layer 320 viewed from under.
- [144] As explained above, the lower portion of the horn 100 and the upper portion of the guide 200 are formed on the second layer 320. Referring to Fig. 54, there is an opening formed on a planar side of the second layer 320 (that is, on the upper portion of the second layer 320), which corresponds to the inner opening 140 of the horn 100. The area of the inner opening 140 formed on the second layer 320 is smaller than that of the opening formed on the rear side of the first layer 310. As a result, the protrusion 130 is formed as illustrated in Fig. 48.
- [145] Referring to Fig. 55, on the rear side of the second layer 320 is formed the upper portion of the guide 200.
- [146] Fig. 56 is a perspective view of the third layer 330, Fig. 57 is a plan view of the third layer 330 viewed from above, and Fig. 58 is a rear view of the third layer 330 viewed from under.
- [147] As shown, the lower portion of the guide 200 is formed on the planar side of the third layer 330, including: 1) four direction changing units 211, 212, 213, 214 to change the advancing direction of the electric waves entering the four horns 100; 2) first guide tube 241 to connect the first and second direction changing units 211, 212; 3) a second guide tube 242 to connect the third and fourth direction changing units 213, 214; 4) a relay tube 260 to connect the first and second guide tubes 241, 242; and 5) a mixing tube 280 to mix the electromagnetic waves transferred from the first and second guide tubes 241, 242 via the relay tube 260 and output the waves.
- [148] The direction changing units 211, 212, 213, 214 include protruding ends 221, 222,

223, 224, and reflecting surfaces 231, 232, 233, 234. Each of the protruding ends 221, 222, 223, 224 extends upward from the bottom of one side of the direction changing unit 211, 212, 213, 214. As the electromagnetic waves entering through the horns 100 hit the protruding ends 221, 222, 223, 224, the waves change direction to face the reflecting surfaces 231, 232, 233, 234.

[149] The reflecting surfaces 231, 232, 233, 234 are formed as triangular columns, on the surfaces of the direction changing units 211, 212, 213, 213 that face the surfaces on which the protruding ends 221, 222, 223, 224 are formed. The reflecting surfaces 231, 232, 233, 234 reflect the electromagnetic waves whose direction is changed due to the protruding ends 221, 222, 223, 224, so that the electromagnetic waves enter into the guide tubes 241, 242.

[150] The first protruding end 221 and the first reflecting surface 231 of the first direction changing unit 211 are in symmetric mirror image with the second protruding end 222 and the second reflecting surface 232 of the second direction changing unit 212. The third protruding end 223 and the third reflecting surface 233 of the third direction changing unit 213 are in symmetric mirror image with the fourth protruding end 224 and the fourth reflecting surface 234 of the fourth direction changing unit 214.

[151] The first guide tube 241 mixes the electromagnetic waves, which changed direction of movement at the first and second direction changing units 211, 212, and provides the electromagnetic waves to the relay tube 260. The second guide tube 242 mixes the electromagnetic waves, which changed direction of movement at the third and fourth direction changing units 213, 214, and provides the electromagnetic waves to the relay tube 260. The first and second guide tubes 241, 242 are in symmetry with the relay tube 260.

[152] The first guide tube 241 includes a step 251. Accordingly, one and the other ends of the first guide tube 241, which are connected to the first and second direction changing units 211, 212, have wider widths than that of the middle portion. One single step 251 or more than one steps 251 may be formed.

[153] Likewise, the second guide tube 242 includes a step 252. Accordingly, one and the other ends of the second guide tube 242, which are connected to the third and fourth direction changing units 213, 214, have wider widths than that of the middle portion. One single step 252 or more than one steps 252 may be formed.

[154] The first and second guide tubes 241, 242 are connected with each other by the relay tube 260 by their middle portions. The relay tube 260 is a linear tube, which has a narrow width in the middle portion than in one and the other ends. To achieve this, the relay tube 260 includes a protruding portion 270 extending inward by a predetermined length from a wall connected to the mixing tube 280.

[155] Although the protruding portion 270 is formed on a wall that is connected to the

mixing tube 280, this is not limited. For example, the protruding portion 270 may be formed on the opposite wall. Furthermore, more than one protruding portion 270 may be formed with various lengths. Therefore, it is possible to adjust the frequency of the electromagnetic waves mixed at the mixing tube 280, by adjusting the number, length, and width of the protruding portions 270.

[156] The mixing tube 280 extends from the middle portion of the relay tube 260, bent once to parallel relation with the relay tube 260, and bent again to form a right angle with the relay tube 260.

[157] A slant surface is formed on the outer edge of the first bent of the mixing tube to change the advancing direction of the electromagnetic waves, and another slant surface 292 is formed on the outer edge of the second bent to change the advancing direction of the electromagnetic waves.

[158] Accordingly, the electromagnetic waves entering through the relay tube 260 are mixed at the mixing tube 280, change the direction due to the slant surfaces 291, 292, and exit.

[159] The process of the horn array antenna 10 for single linear polarization receiving the electromagnetic waves will be explained below.

[160] Electromagnetic waves enter into the outer opening 110 of the horn 100, and guided along the inclined portion 120. The linear polarization having the direction of electric field that is same as the wider width of the inner opening 140, does not pass the inner opening 140, while the linear polarization having the direction of electric field that is same as the narrower width of the inner opening 140 - the width is reduced due to the presence of the protrusion 130 - passes the inner opening 140 and enters the guide 200.

[161] Specifically, the linear polarization that passes the inner opening 140 moves to the direction changing units 211, 212, 213, 214 formed on the guide 200, hits the protruding ends 221, 222, 223, 224 formed on the direction changing units 211, 212, 213, 214 and changes the advancing direction. The linear polarization having changed direction is reflected against the reflecting surfaces 231, 232, 233, 234, and enters the guide tubes 241, 242.

[162] After entering from the first and second direction changing units 211, 212 into the first guide tube 241, the linear polarization is mixed at the middle portion of the first guide tube 241 and enters into the relay tube 260. The linear polarization entering from the third and fourth direction changing units 213, 214 into the second guide tube 242, is mixed at the middle portion of the second guide tube 242 and enters into the relay tube 260.

[163] As the linear polarizations from the first and second guide tubes 241, 242 enter into the relay tube 260, the linear polarizations start to be mixed with each other in the middle portion of the relay tube 260, and advance to the mixing tube 280. The linear

polarization entering the mixing tube 280 change the advancing direction due to the slant surfaces 291, 292, and move to be discharged.

[164] The process of the horn array antenna 10 for single linear polarization transmitting the electromagnetic waves will be explained below.

[165] The linear polarization waves enter the mixing tube 280 of the guide 200, and split into two streams in the middle portion of the relay tube 250 which are guided into the first and second guide tubes 241, 242, respectively. Accordingly, the waves advance along the first and second guide tubes 241, 242 and move forward to one and the other ends of the first and second guide tubes 241, 242.

[166] The split streams of the linear polarization are reflected against the reflecting surfaces 231, 232, 233, 234 of the direction changing units 211, 212, 213, 214, and provided to the protruding ends 221, 222, 223, 224. The linear polarization provided to the protruding ends 221, 222, 223, 224 change the direction of movement toward the horns 100 as it hits upon the protruding ends 221, 222, 223, 224, and radiated to outside through the inclined portions 120 of the horns 100.

[167] Although the horn array antenna 10 for single linear polarization explained above employs four horns 100, this is only for illustrative purpose. Therefore, it is possible that the horn array antenna 10 for single linear polarization according to embodiments of the present invention can employ more than, or less than four horns 100 as occasion demands.

[168] Meanwhile, in order to improve the receptivity of the single linear polarization at the horn array antenna 10 for single polarization, it is necessary that the entering linear polarization has the direction of electric field that is parallel to the shorter sides of the inner opening 140 (Fig. 59). Referring to Fig. 60, if the linear polarization entering has the direction of electric field that is not parallel to the shorter sides of the inner opening 140, the horn array antenna 10 for single linear polarization has bad receptivity of linear polarization.

[169] However, the receptivity of linear polarization may still be good even when the linear polarization entering has the direction of electric field that is inclined, rather than parallel to the shorter sides of the inner opening 140. That is, referring to Fig. 61, there is a comb-pattern skew filter provided to the horn array antenna 10 for single linear polarization.

[170] The teeth of the comb-like skew filter are formed at a predetermined angle with respect to the vibrating direction of the electric field of the second polarization being introduced. For example, the predetermined angle may be 90°. However, the angle of 90° is only an example, and accordingly, more or less than 90° may be adaptively applied depending on the given transmission and reception environment.

[171] Meanwhile, the angle of incidence of the linear polarization is different depending on

the location (latitude and longitude) of the area where the horn array antenna 10 is used, and this means that the angle of incidence of the linear polarization can be computed based on the latitude and longitude of the location to receive the linear polarization. Accordingly, based on the latitude and longitude of the area to receive the linear polarization, the angle of teeth of the skew filter can be decided.

- [172] The skew filter may be embodied using conductive materials such as copper, nickel, or iron, or alternatively, the skew filter may desirably be embodied by plating synthetic resin with an adequate conductive material. The skew filter may preferably have 0.03mm to 1mm of thickness, but this may vary as occasion demands.
- [173] Figs. 62 to 65 illustrate a method for applying a skew filter to the horn array antenna 10 for single linear polarization according to embodiments of the present invention.
- [174] Referring to Fig. 62, a skew filter 410 provided as a film may be inserted between the first and second layers 310, 320. Secondly, referring to Fig. 63, a skew filter may be formed directly on the upper portion of the second layer 320.
- [175] According to the abovementioned first and second methods, the skew filter is formed on the lower portion of the horns 100. The ends of the teeth of the skew filter are in contact with the edge of the inner opening 140.
- [176] Thirdly, and referring to Fig. 64, a film type of skew filter 420 may be attached to the upper portion of the first layer 310. Fourthly, and referring to Fig. 65, a skew filter may be formed directly on the upper portion of the first layer 310.
- [177] According to the third and fourth methods explained above, the skew filter is formed on the upper side of the horns 100. The ends of the teeth of the skew filter are in contact with the edge of the outer opening 110.
- [178] The number of teeth of the skew is not limited, and therefore, one or more than one teeth may be formed as occasion demands. Furthermore, the width of the tooth, and the intervals between the teeth are not limited. The ends of the teeth may desirably be rounded. Refer to Figs. 37 to 41 for variations of the skew filter.
- [179] It is possible that the ends of the teeth of the skew filter are not in contact with the edges of the inner opening 140 or outer opening 110. The ends of the teeth may still be rounded. Figs. 42 to 44 illustrate skew filters whose ends are not in contact with the edges of the inner opening 140. The skew filters illustrated have one tooth, but one will understand that two or more teeth may be employed. Although not illustrated, one will understand that the skew filters may be embodied so that the teeth are not in contact with the edges of the outer opening 110.
- [180] Note that only the film type skew filter can have ends of the teeth that do not contact the inner or outer opening 140, 110, and it is necessary to coat the skew filter as a thin layer of nonconductive material to fix the teeth in position.
- [181] The teeth of the skew filter may be formed in various manners other than the

examples provided above.

- [182] In the horn array antenna 10 for single linear polarization explained above according to the embodiments of the present invention, the inner openings 140 are parallel to the outer openings 110 (that is, the edges of the inner openings 140 are parallel to the edges of the outer openings 110). However, even when the inner and outer openings 140, 110 are not parallel, for example, even when the edges of the inner openings 140 are at 45° with respect to the edges of the outer openings 110 (Fig. 45), it is still possible to employ the skew filter according to the embodiments of the present invention.
- [183] Furthermore, although the process of the horn array antenna for single linear polarization receiving the polarization has been explained so far, one will understand that the same applies to the case of transmitting the polarization so that it is possible to use the skew filter to transmit the polarization having certain degrees of inclination.
- [184] Two overlaying skew filters may be used, and a spacer may be inserted between the horn array antenna 10 and the skew filter or between the skew filters to provide a space there between. Refer to the detailed explanation about the spacer provided above with reference to Figs. 46 and 47.
- [185] Although the horn array antenna for single linear polarization having a skew filter has been explained above, one will note that the skew filter can be fabricated separately.
- [186] Fig. 66 is a graphical representation showing movement of a main beam center according to skew filter. Referring to Fig. 66, PHI has the highest gain at 90° when the skew filter is 0° . The center of the beam gradually moves as the skew filter moves to 90° . A certain level of gain is maintained regardless of the movement of the skew filter. However, the gain decreases as the skew filter passes a certain point.
- [187] Fig. 67 is a view illustrating an example where a skew filter is applied and Fig. 68 is a view illustrating an angle of a skew filter. Fig. 67 shows a skew filter having an embedded antenna, and referring to Fig. 68, the center of the main beam is changeable according to the change of angle. The reference character 'A' in Fig. 68 denotes an angle.
- [188] Fig. 69 is a view illustrating the simulation result obtained at an angle of 0° , Fig. 70 is a view illustrating the simulation result obtained at an angle of 15° , Fig. 71 is a view illustrating the simulation result obtained at an angle of 30° , Fig. 72 is a view illustrating the simulation result obtained at an angle of 45° , and Fig. 73 is a view illustrating the simulation result obtained at an angle of 75° .
- [189] Referring to Figs. 69 to 73, the center of the beam is approximately 90° when $A = 0$, approximately 100° when $A = 15$, approximately 118° when $A = 30$, approximately 122° when $A = 45$, and approximately 141° when $A = 75$.

[190] While the invention has been shown and described with reference to certain embodiments to carry out this invention, it will be understood by those skilled in the art that various changes in form and details may be made therein without departing from the spirit and scope of the invention as defined by the appended claims.

[191]

Claims

- [1] A horn array antenna for receiving at least one polarization, comprising:
a square-shaped horn portion which transmits and receives the polarization; and
a skew filter having a direction so as to be inclined with respect to a direction of
the square of the square-shaped horn portion.
- [2] The horn array antenna of claim 1, wherein the skew filter has a comb-like
shape.
- [3] The horn array antenna of claim 2, wherein a tooth of the comb-like skew filter
has an angle which is determined based on at least one from among an angle of
incidence of the polarization, and a location of the horn array antenna.
- [4] The horn array antenna of claim 2, wherein the comb-like skew filter has at least
one tooth.

[Fig. 1]

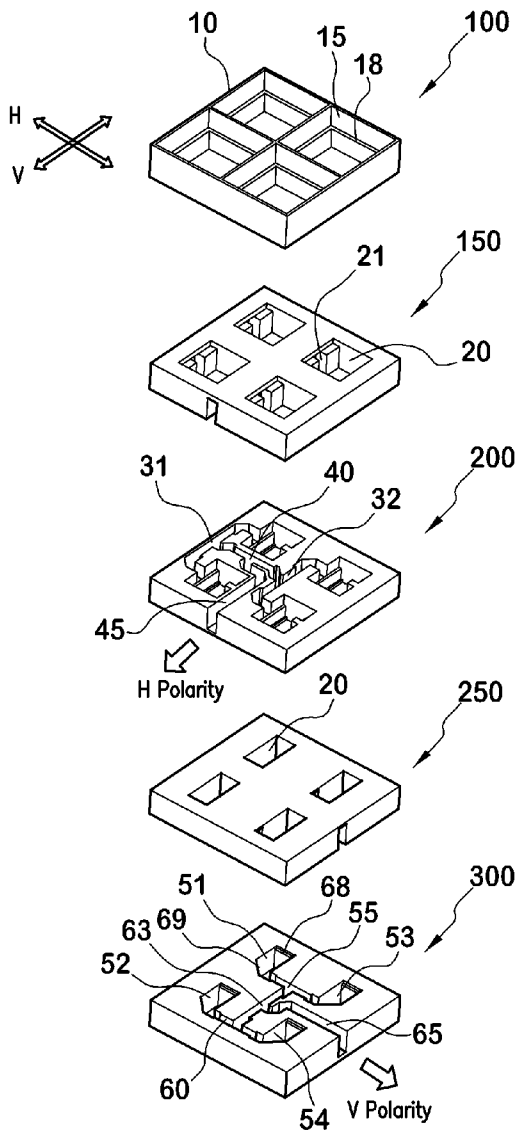

[Fig. 2]

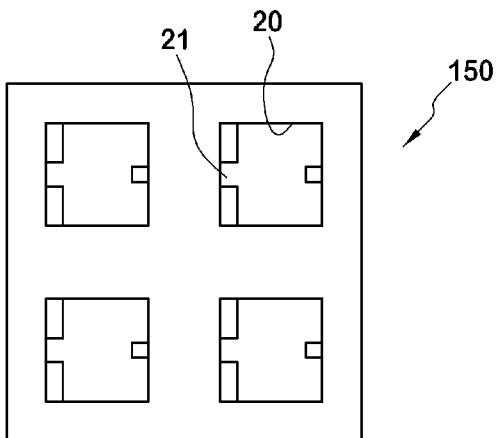

[Fig. 3]

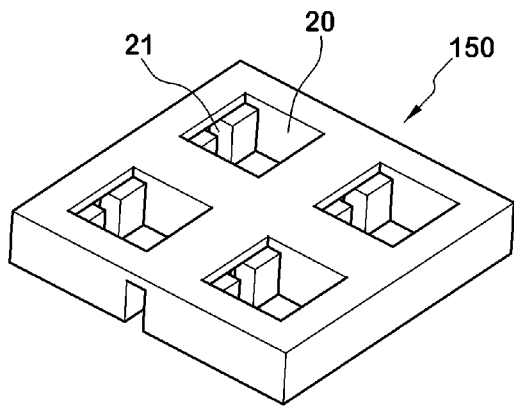

[Fig. 4]

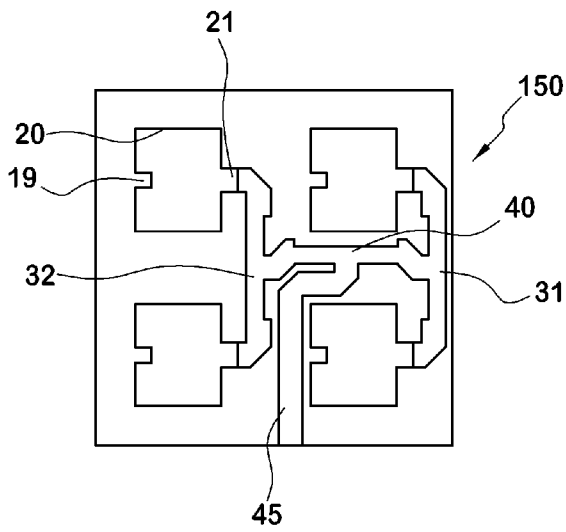

[Fig. 5]

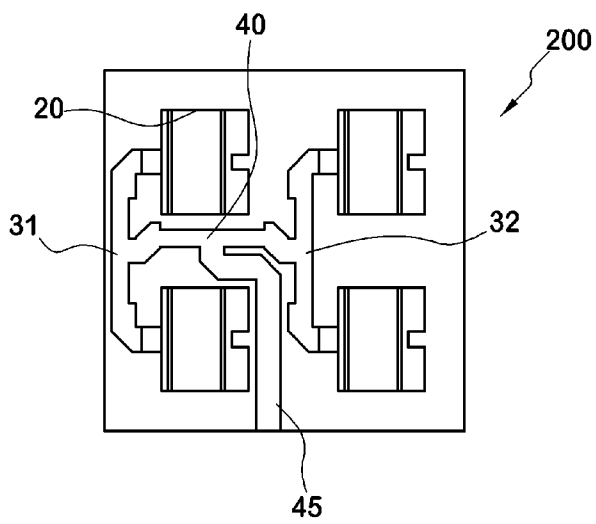

[Fig. 6]

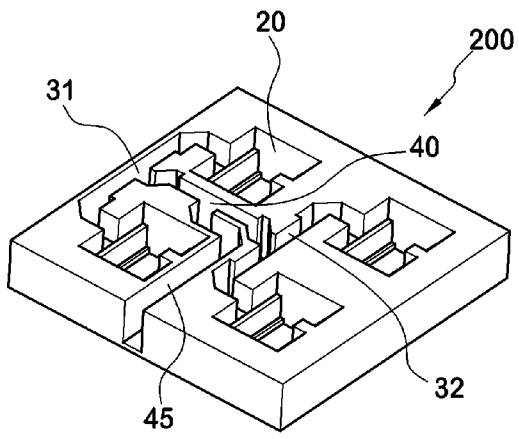

[Fig. 7]

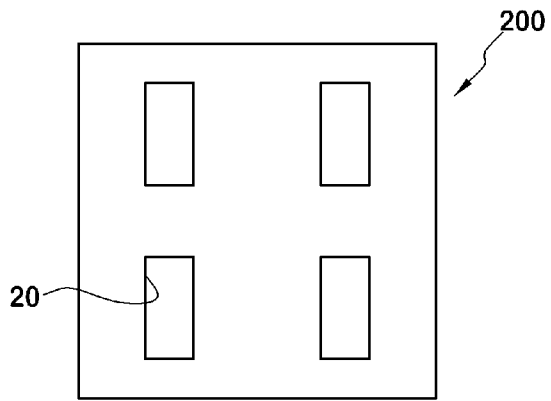

[Fig. 8]

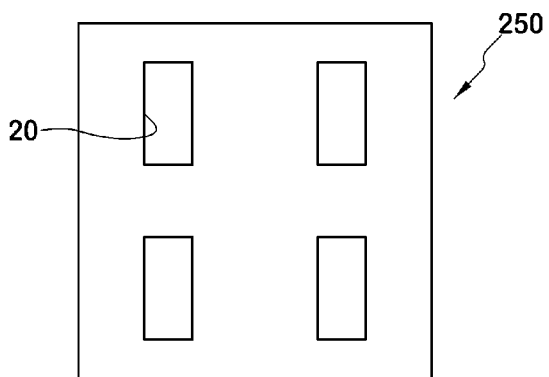

[Fig. 9]

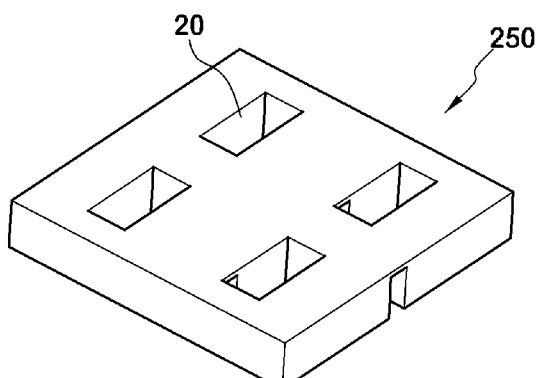

[Fig. 10]

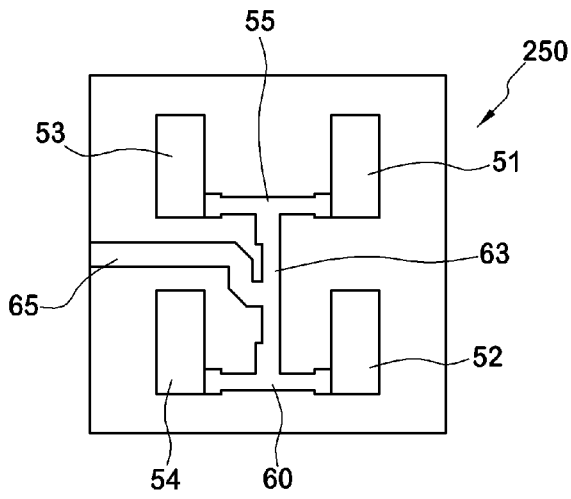

[Fig. 11]

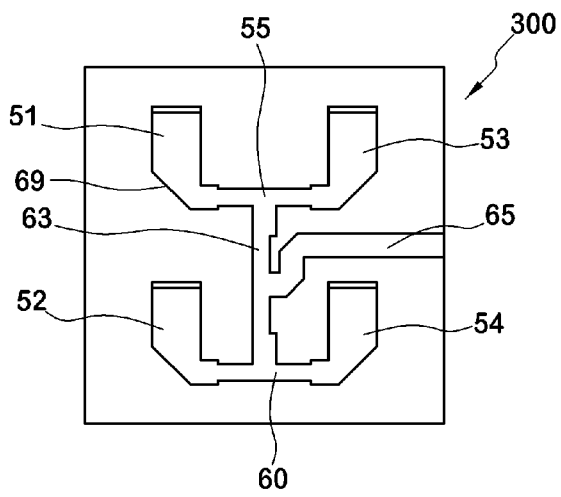

[Fig. 12]

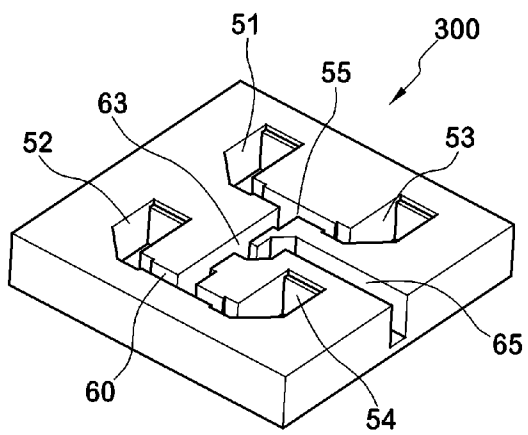

[Fig. 13]

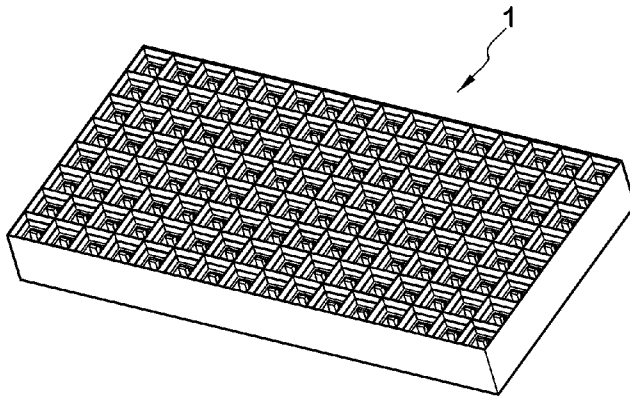

[Fig. 14]

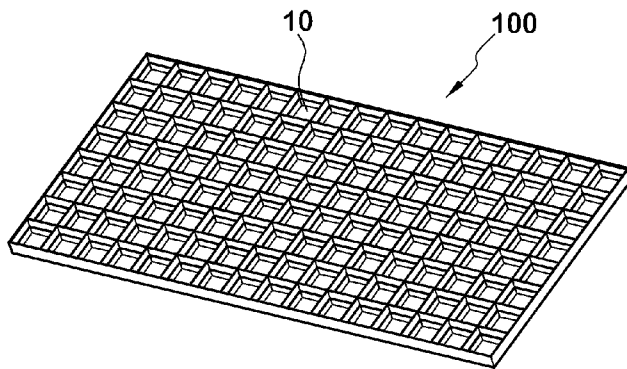

[Fig. 15]

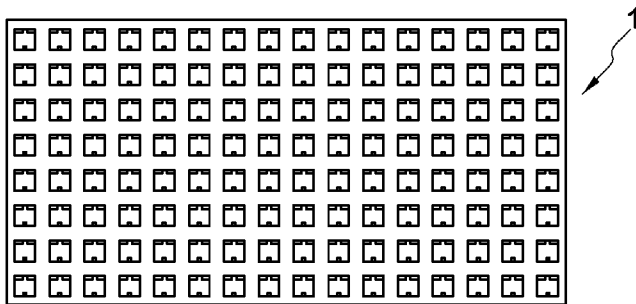

[Fig. 16]

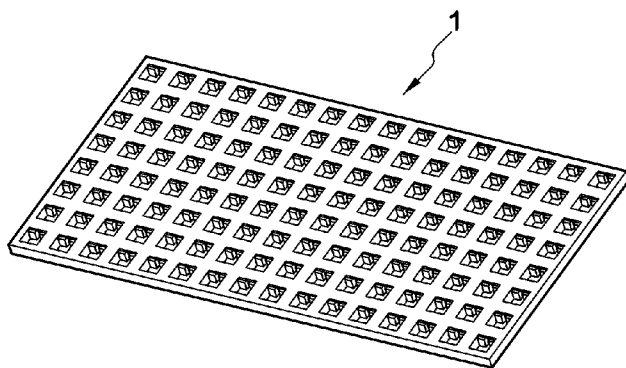

[Fig. 17]

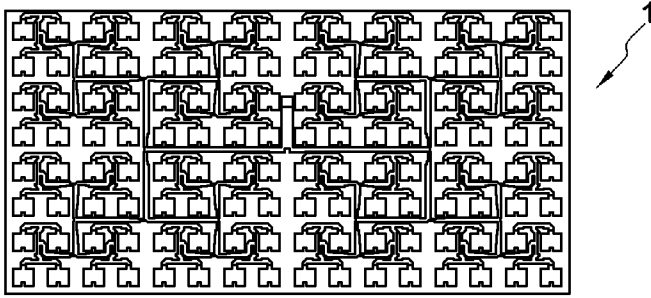

[Fig. 18]

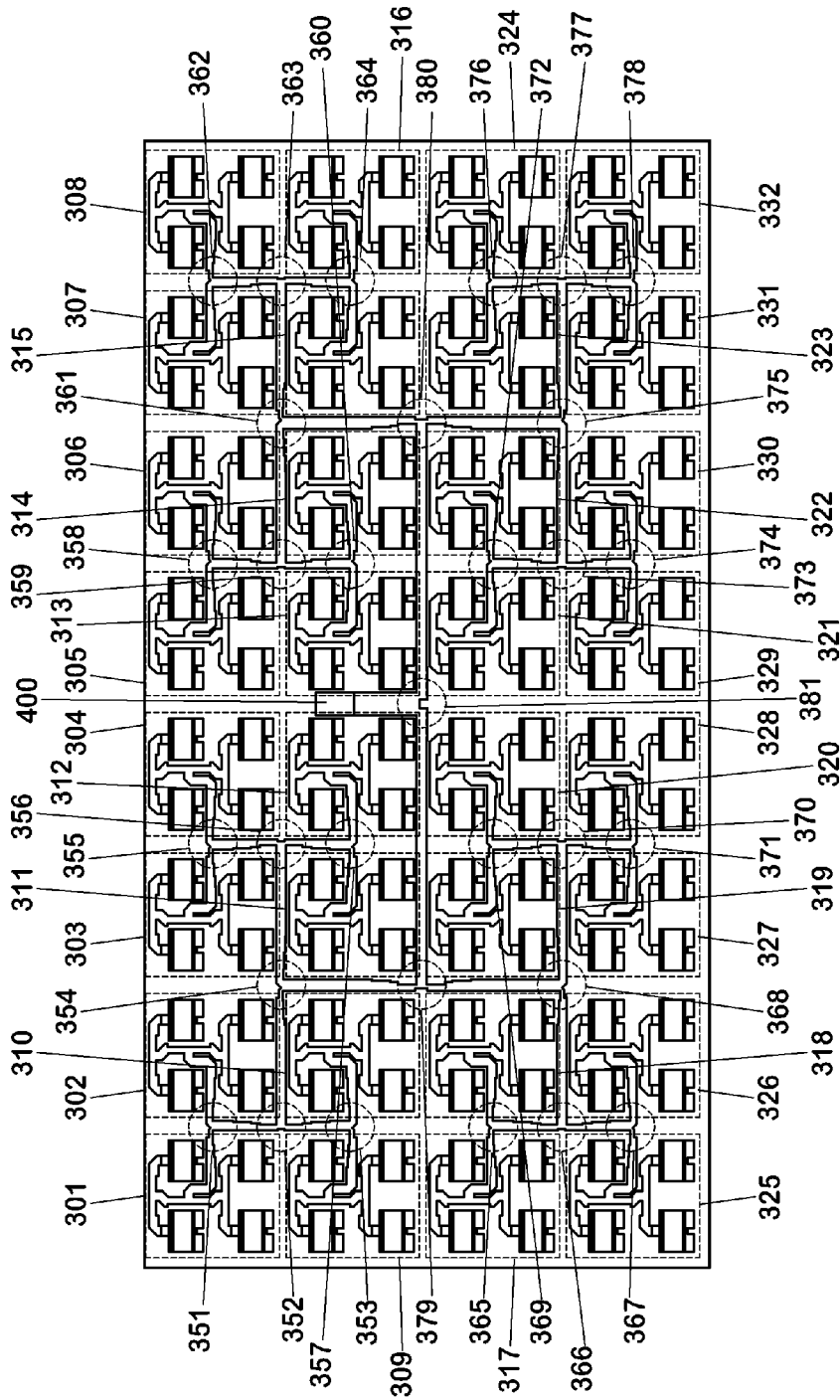

[Fig. 19]

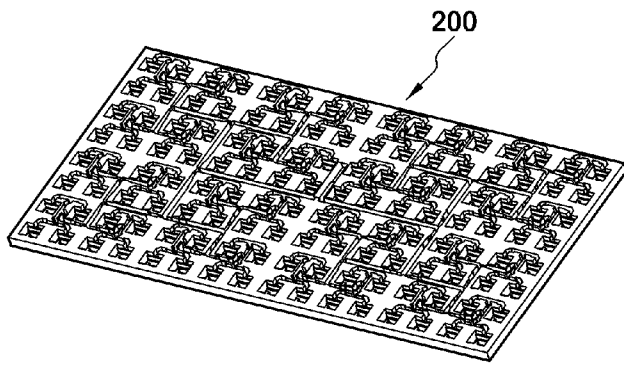

[Fig. 20]

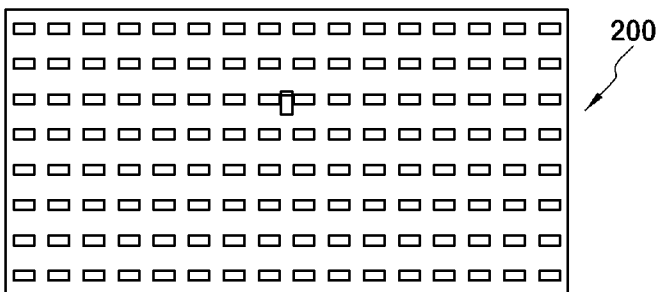

[Fig. 21]

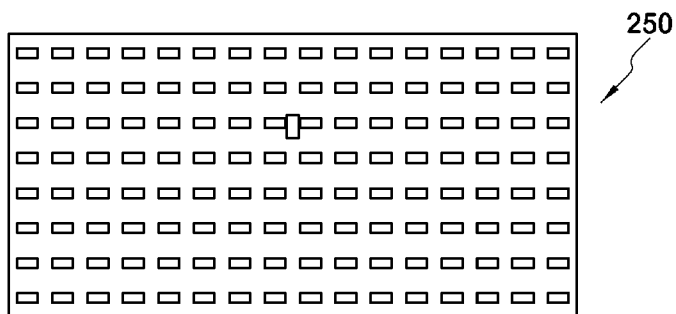

[Fig. 22]

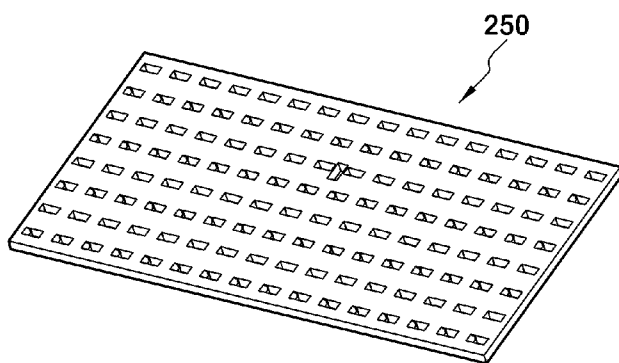

[Fig. 25]

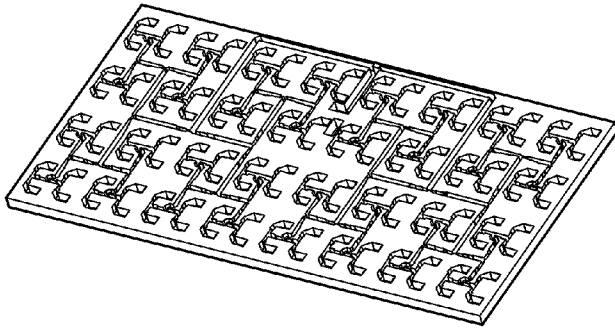

[Fig. 26]

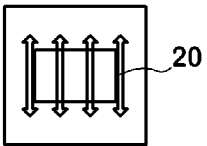

[Fig. 27]

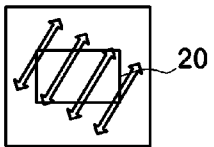

[Fig. 28]

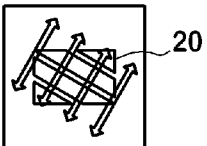

[Fig. 29]

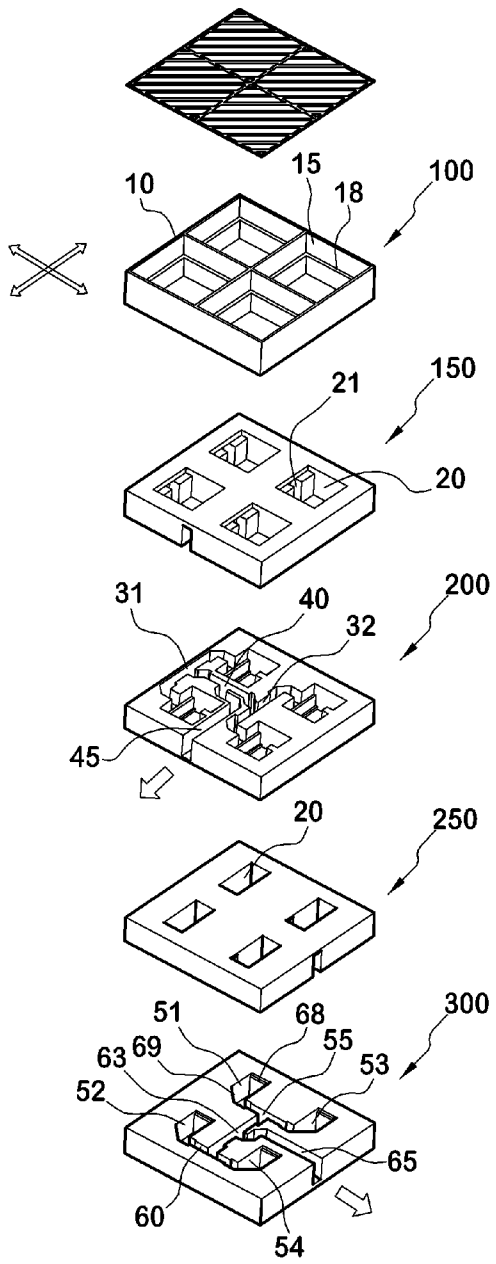

[Fig. 30]

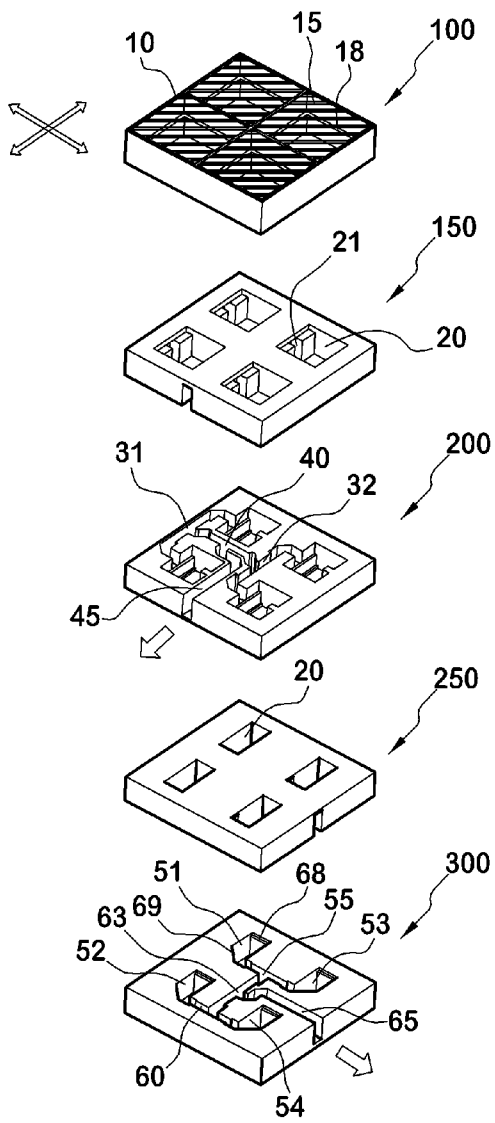

[Fig. 31]

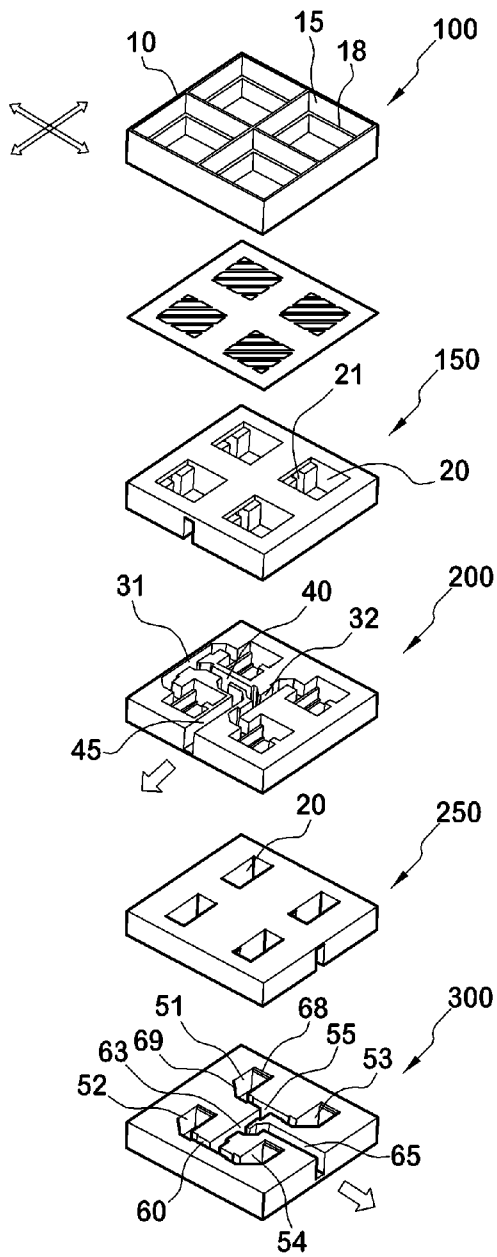

[Fig. 32]

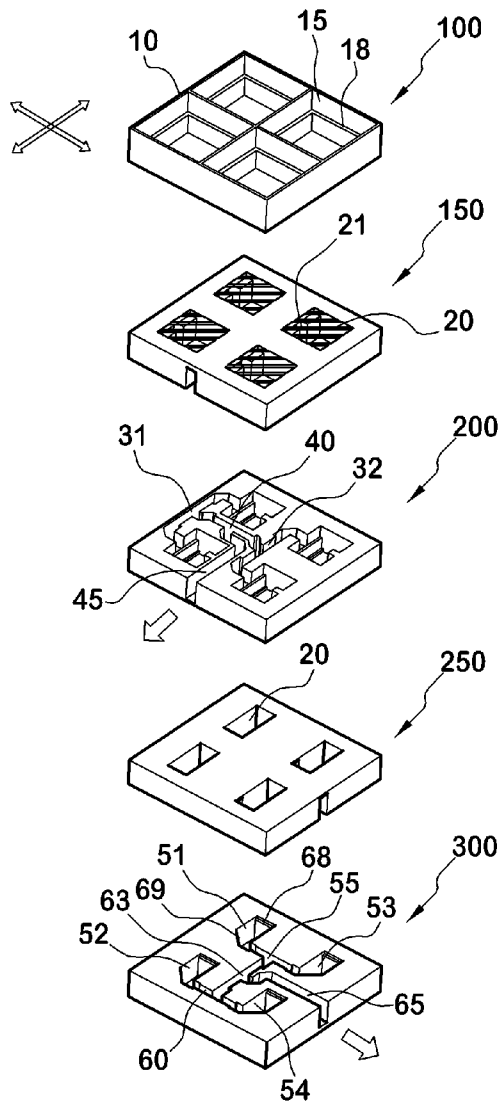

[Fig. 33]

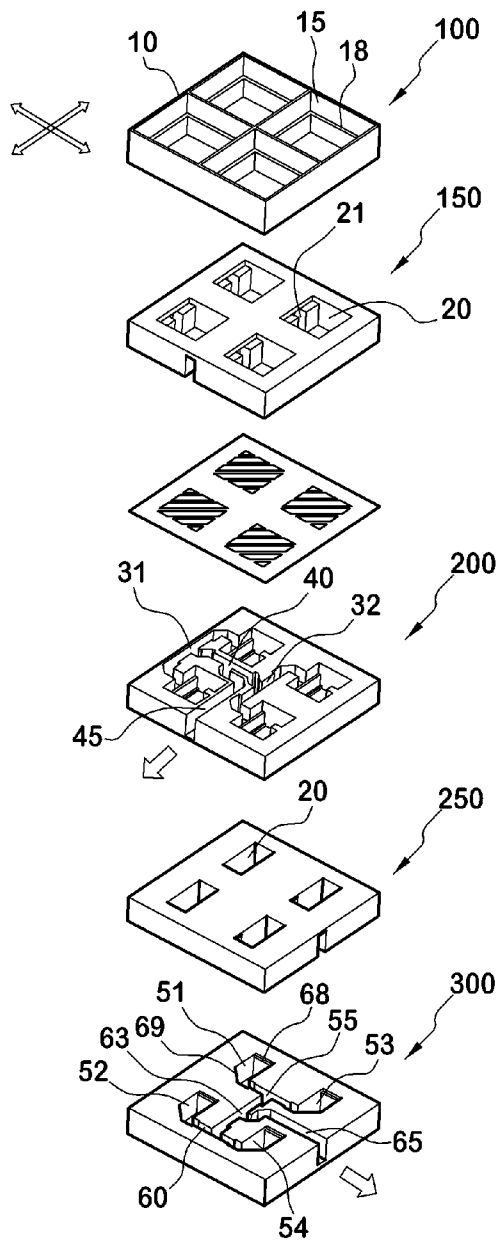

[Fig. 34]

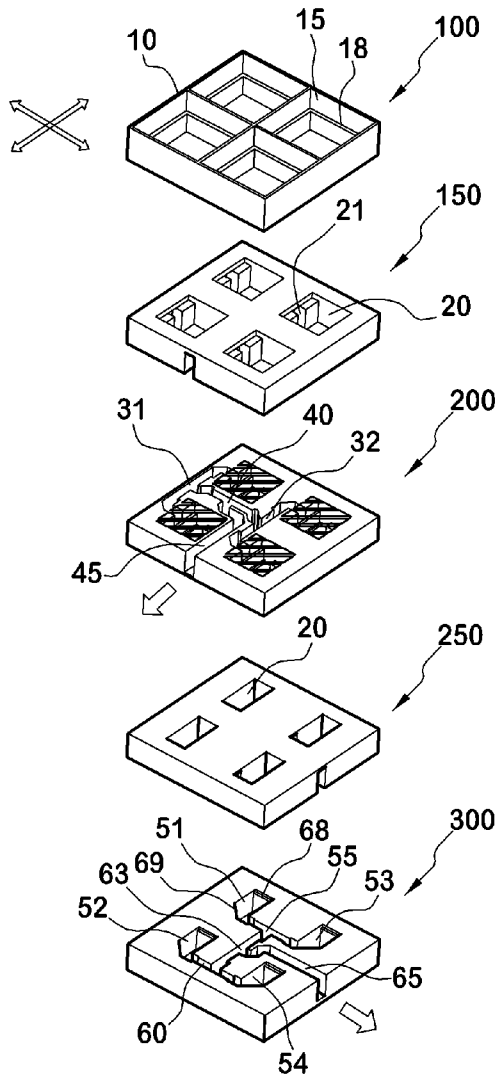

[Fig. 35]

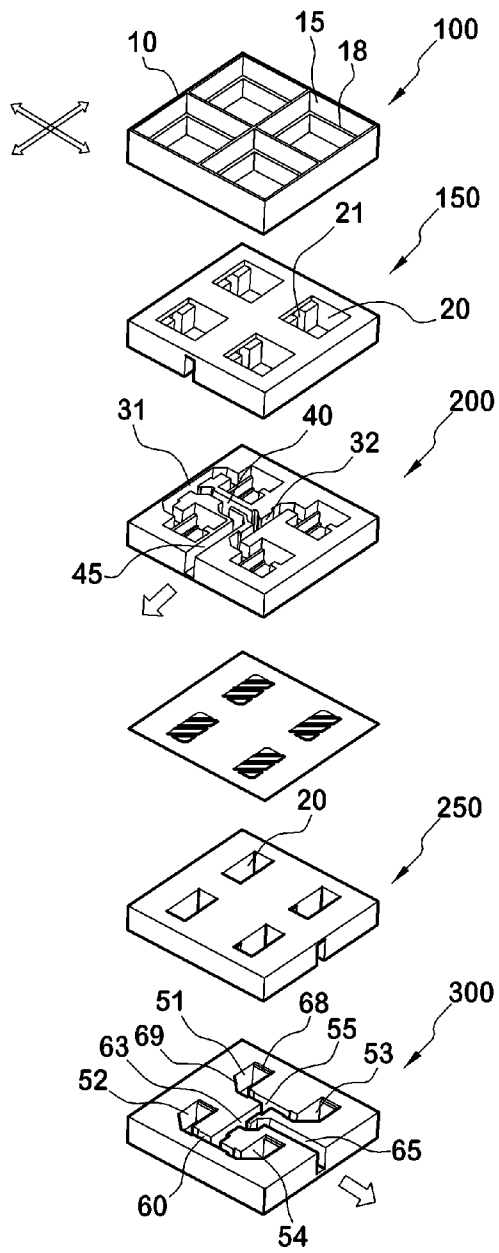

[Fig. 36]

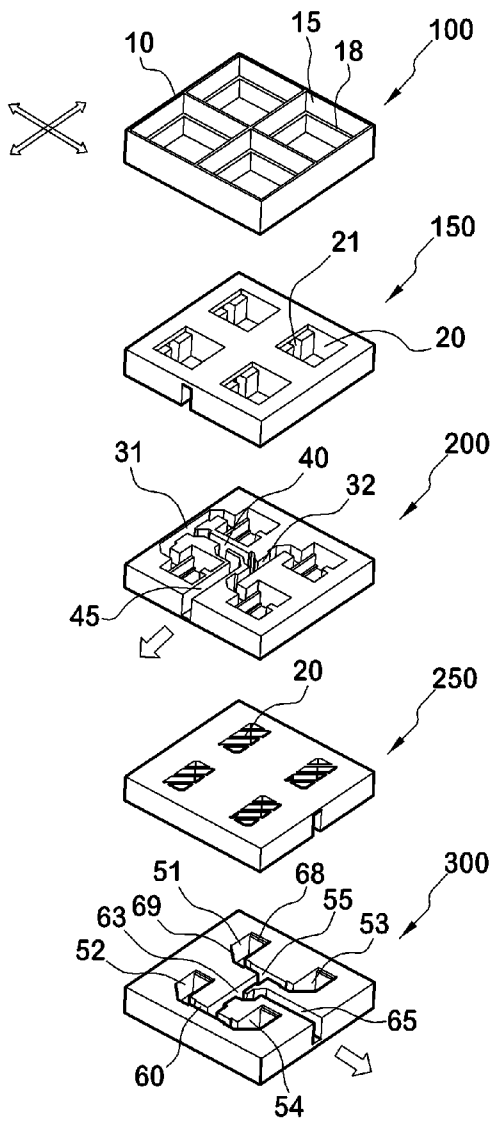

[Fig. 37]



[Fig. 38]

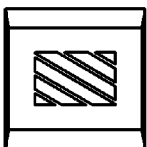

[Fig. 39]



[Fig. 40]

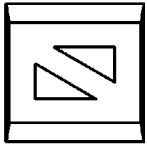

[Fig. 41]



[Fig. 42]

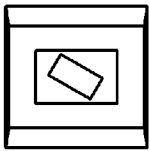

[Fig. 43]

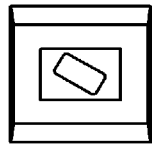

[Fig. 44]

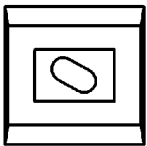

[Fig. 45]

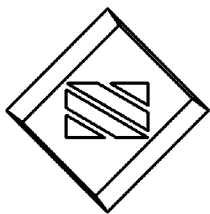

[Fig. 46]

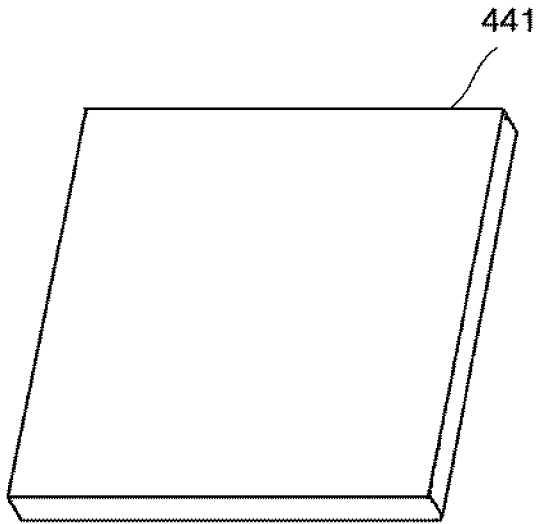

[Fig. 47]

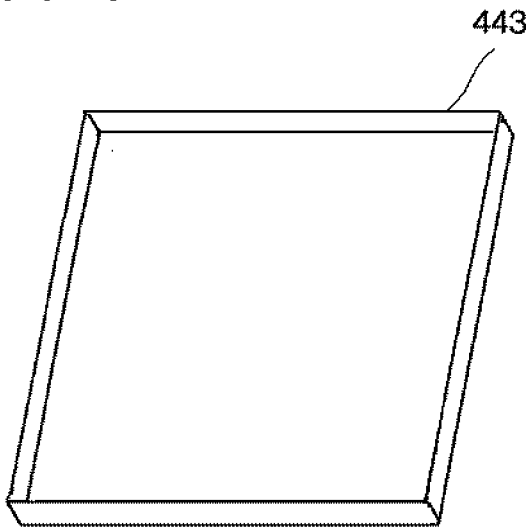

[Fig. 48]

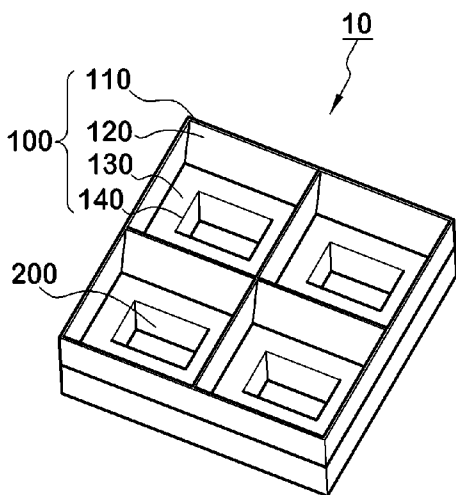

[Fig. 49]

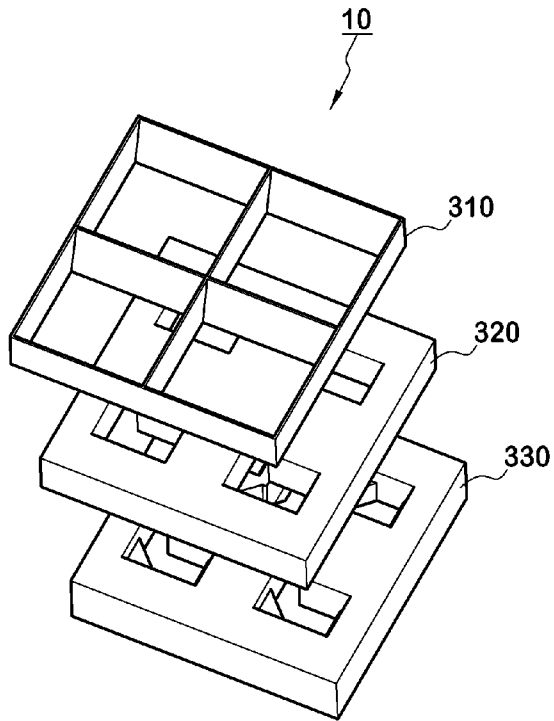

[Fig. 50]

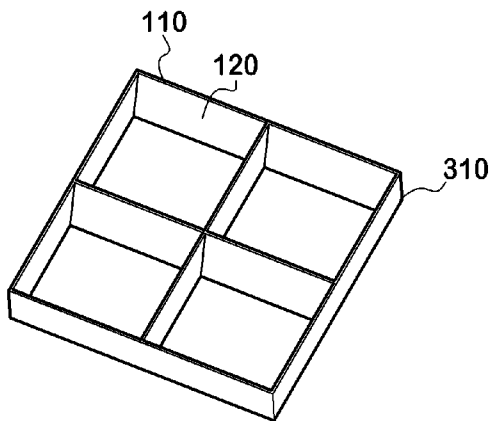

[Fig. 51]

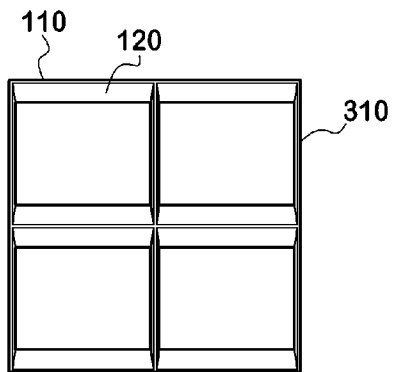

[Fig. 52]

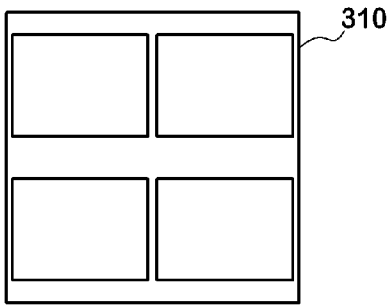

[Fig. 53]

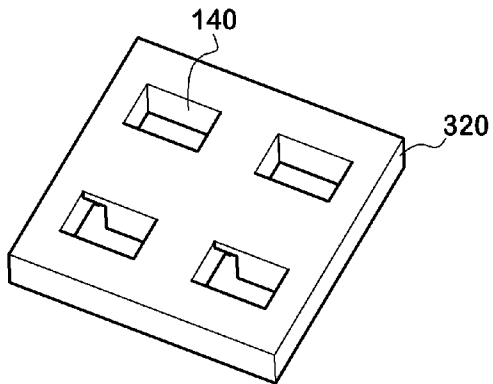

[Fig. 54]

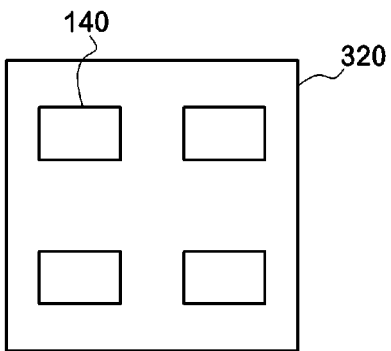

[Fig. 55]

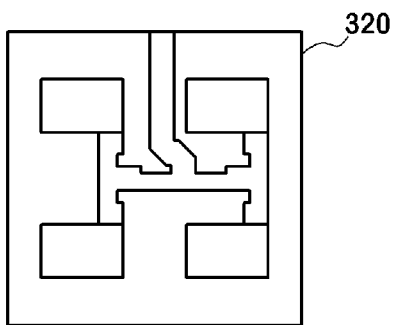

[Fig. 60]

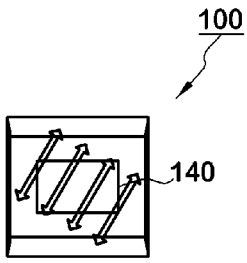

[Fig. 61]

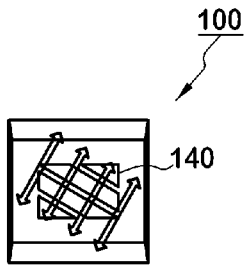

[Fig. 62]

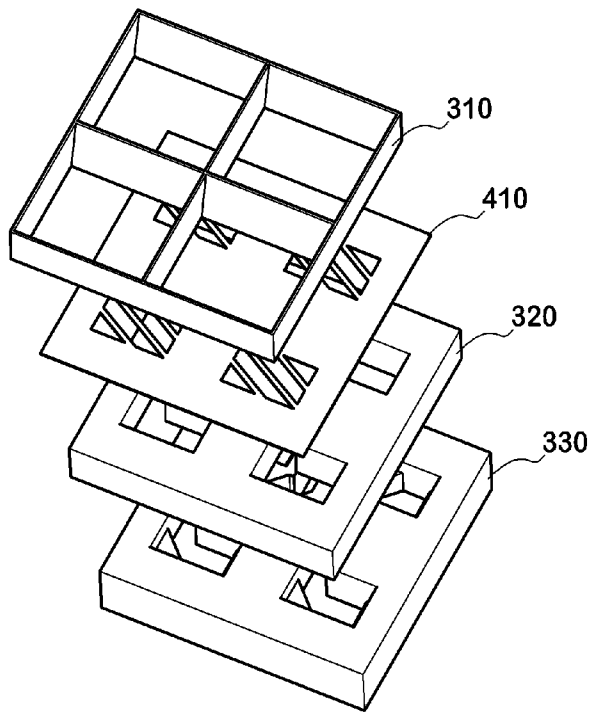

[Fig. 63]

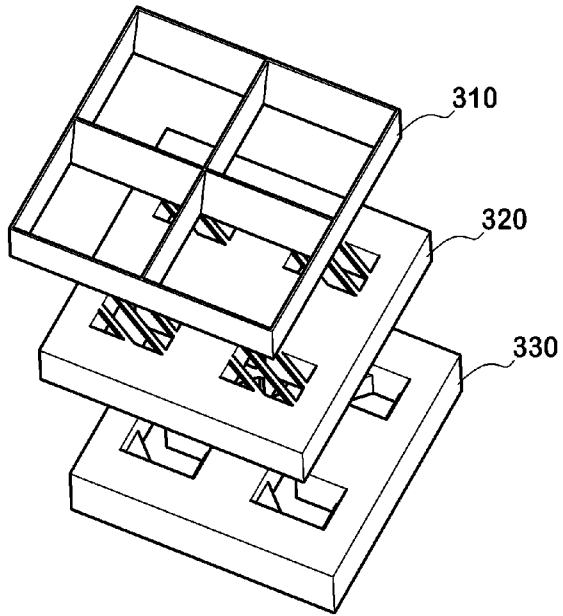

[Fig. 64]

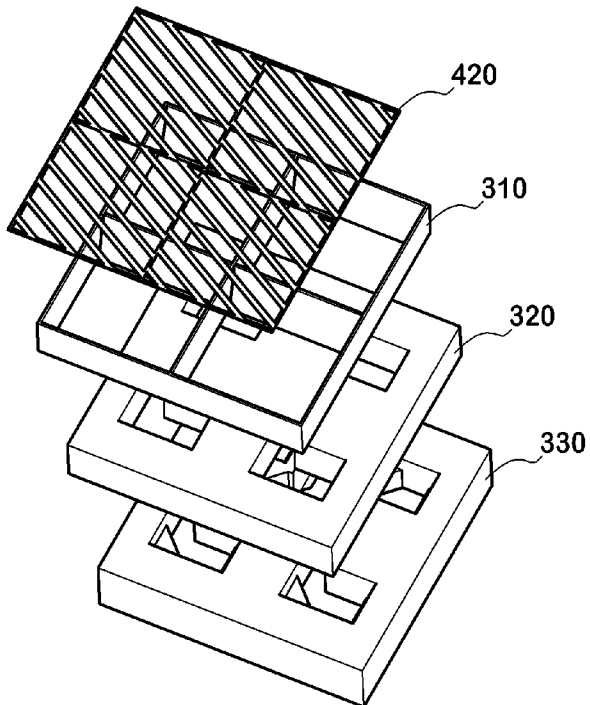

[Fig. 65]

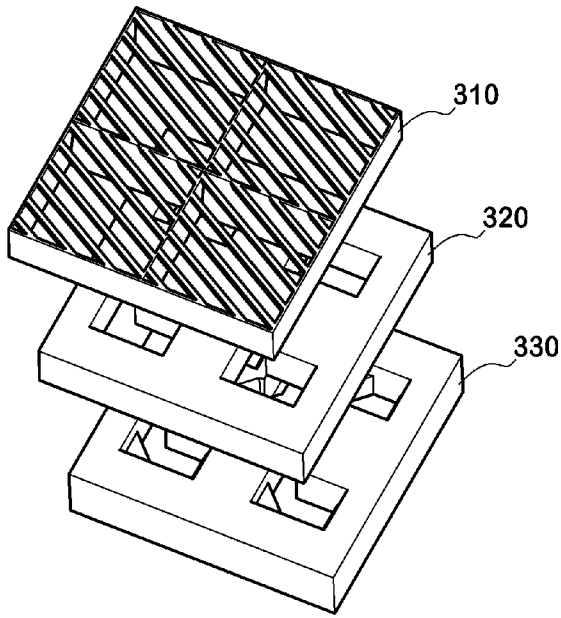

[Fig. 66]

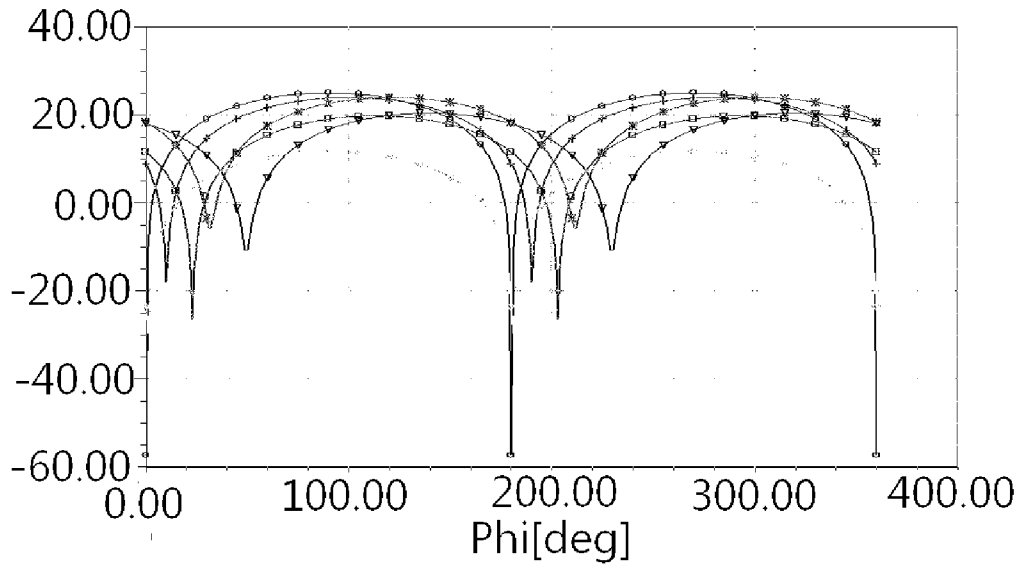

dB(DirPhi)[db]
Setup1:Sweep1

- | | | | |
|-----------------|-----|-----------------|-----|
| \$SP_DEG=0 deg | ○ | \$SP_DEG=45 deg | ○ |
| \$SP_DEG=15 deg | —+— | \$SP_DEG=75 deg | —▽— |
| \$SP_DEG=30 deg | ⋄ | \$SP_DEG=90 deg | ⋄ |

[Fig. 67]

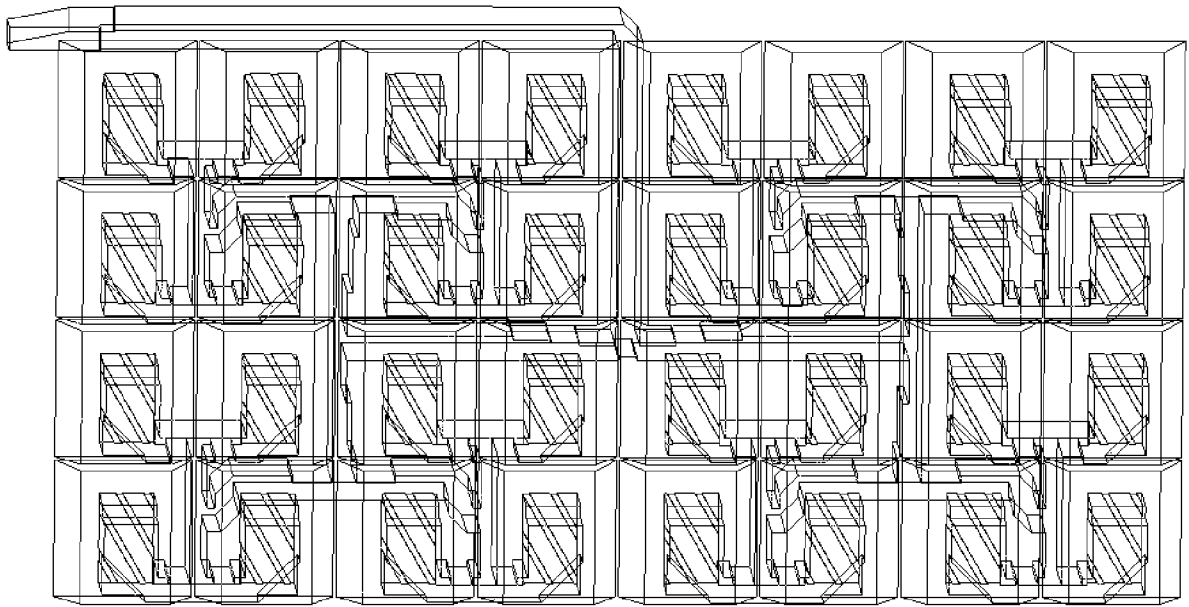

[Fig. 68]

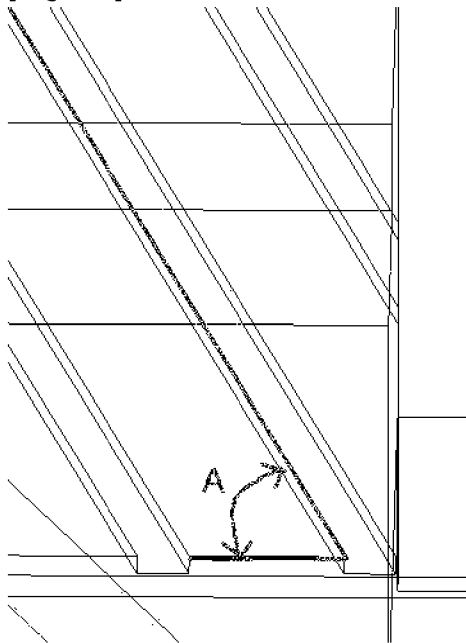

[Fig. 69]

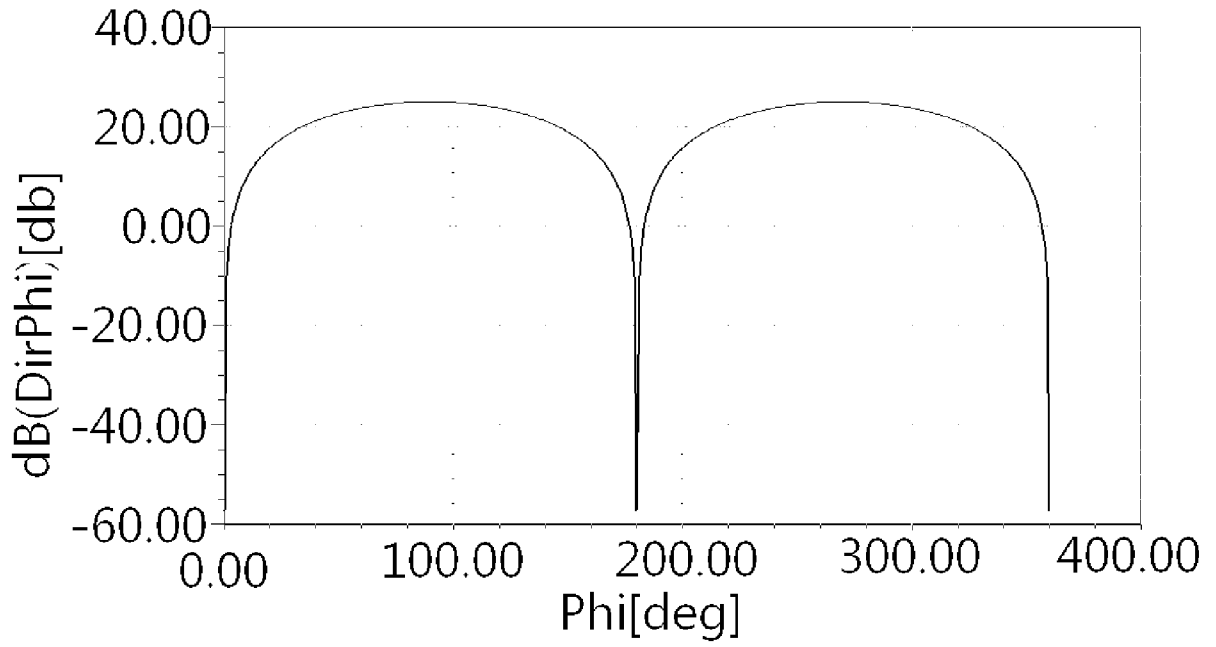

[Fig. 70]

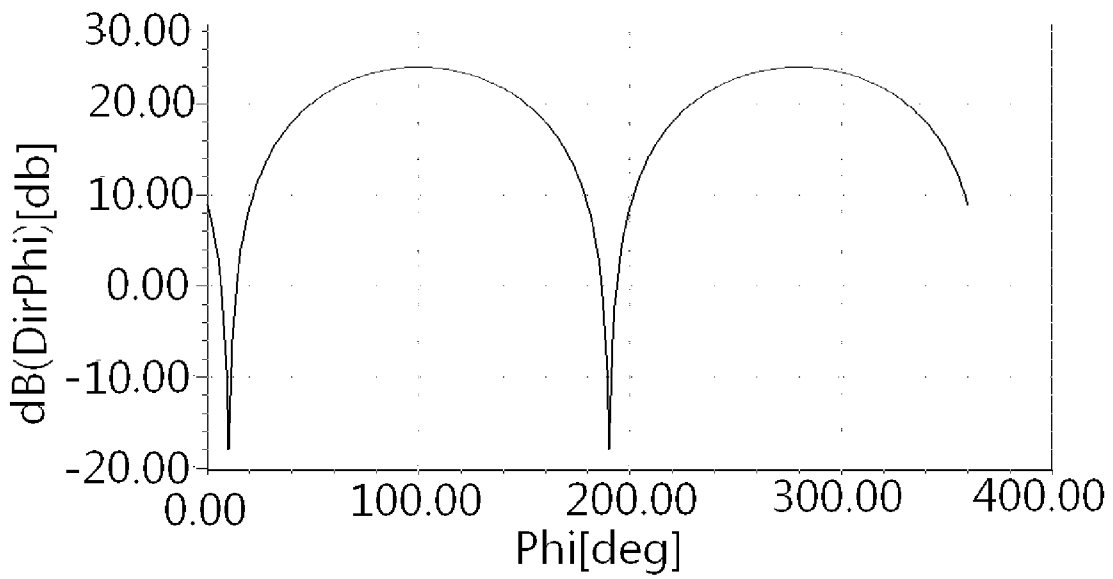

[Fig. 71]

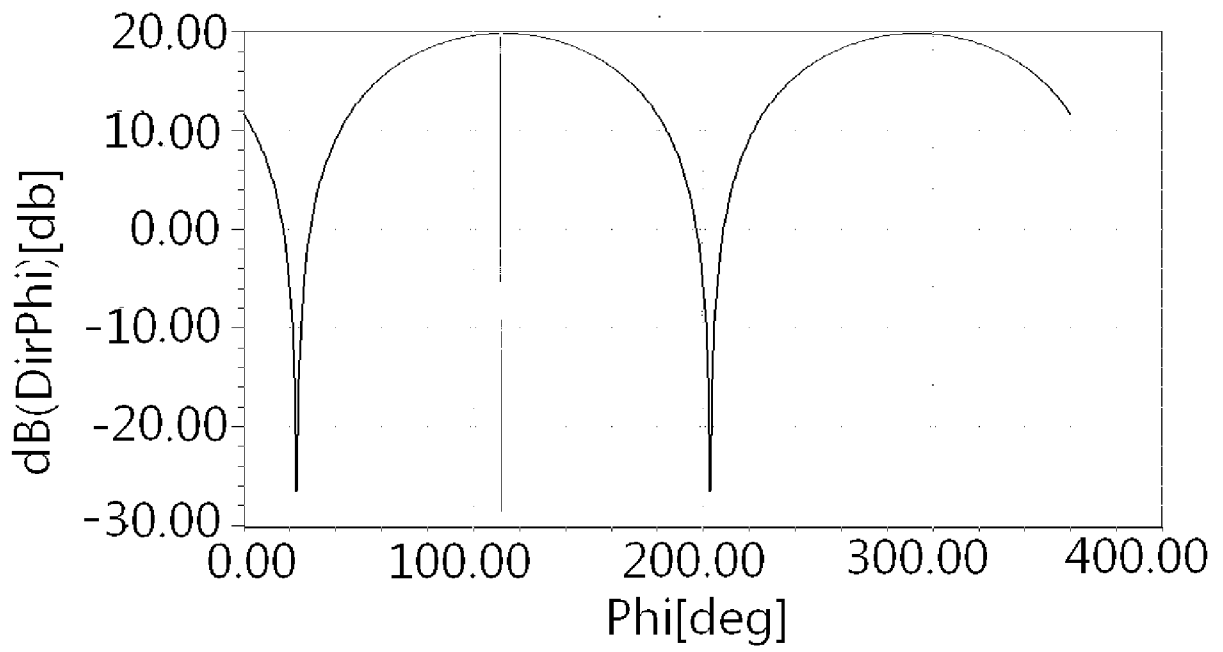

[Fig. 72]

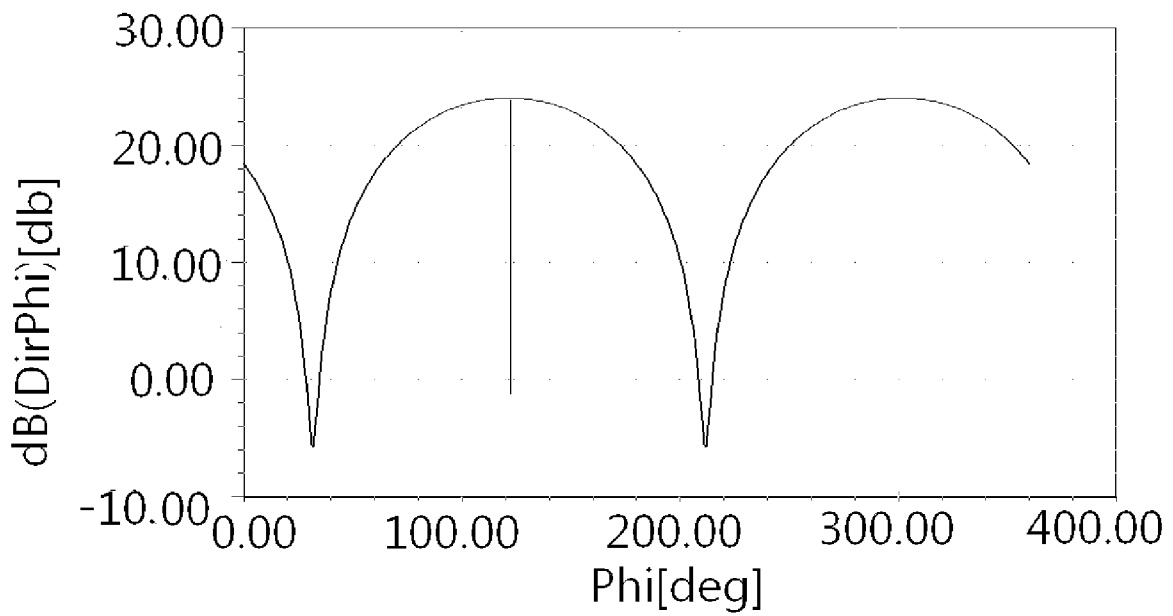

[Fig. 73]

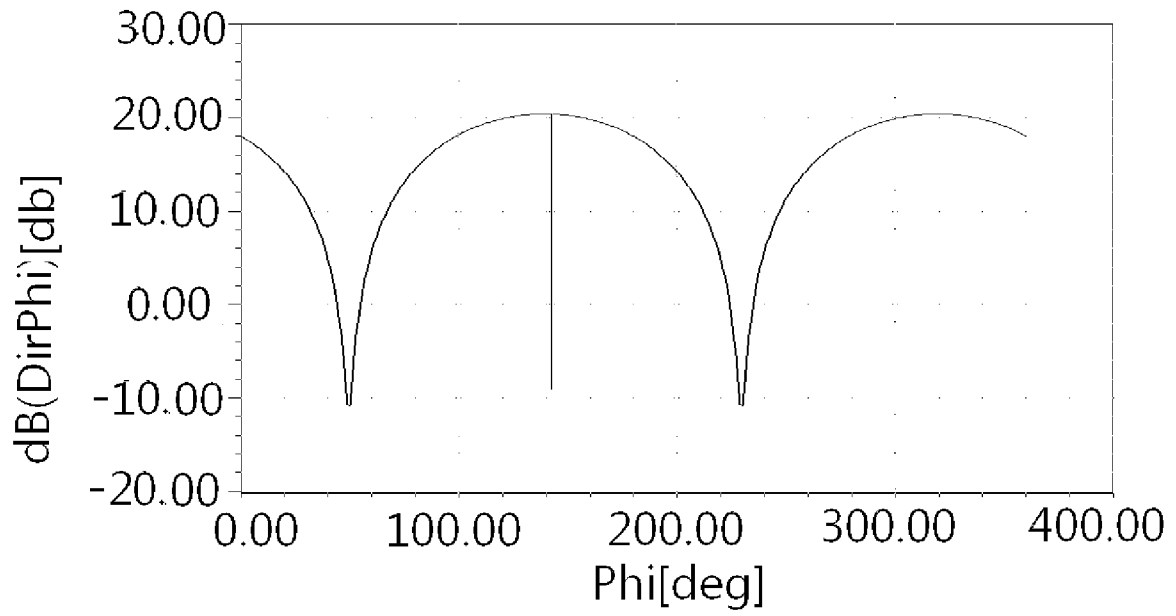

INTERNATIONAL SEARCH REPORT

International application No.
PCT/KR2008/007392**A. CLASSIFICATION OF SUBJECT MATTER***H01Q 13/02(2006.01)i, H01Q 21/00(2006.01)i*

According to International Patent Classification (IPC) or to both national classification and IPC

B. FIELDS SEARCHED

Minimum documentation searched (classification system followed by classification symbols)

IPC 8 H01Q

Documentation searched other than minimum documentation to the extent that such documents are included in the fields searched

Korean Utility models and applications for utility models since 1975
Japanese Utility models and applications for utility models since 1975

Electronic data base consulted during the international search (name of data base and, where practicable, search terms used)

eKIPASS(KIPO Internal)

"Keywords: antenna, horn, array, skew, filter, polariz*, control, change, rotat*, conver*"

C. DOCUMENTS CONSIDERED TO BE RELEVANT

Category*	Citation of document, with indication, where appropriate, of the relevant passages	Relevant to claim No.
Y	WO 9523440 A1 (FORTEL TECHNOLOGY LIMITED) 31 AUGUST 1995 See the abstract; figures 1, 2; pages 3, 4; and claim 1	1~4
Y	WO 03017424 A1 (ARGUS TECHNOLOGIES (AUSTRALIA) PTY LTD et al.) 27 FEBRUARY 2003 See the abstract; figures 1A, 1B; page 4 line 19 ~ line 25; and claim 1	1~4
Y A	US 3754271 A (JAMES J. EPIS) 21 AUGUST 1973 See the abstract; figures 1~6; column 2 line 44 ~ column 4 line 22; and claims 1~4	2~4 1
A	US 5258768 A (TERRY M. SMITH) 2 NOVEMBER 1993 See the abstract; figures 1, 6; column 1 line 4 ~ line 7, column 4 line 7 ~ line 56; and claim 1	1~4
P, Y	WO 2008069358 A1 (IM, SEUNG JOON et. al) 12 JUNE 2008 See the abstract; figures 2~12, 26~72; paragraphs 115~124, 141~218; and claims 1~36	1~4

 Further documents are listed in the continuation of Box C. See patent family annex.

* Special categories of cited documents:

"A" document defining the general state of the art which is not considered to be of particular relevance

"E" earlier application or patent but published on or after the international filing date

"L" document which may throw doubts on priority claim(s) or which is cited to establish the publication date of citation or other special reason (as specified)

"O" document referring to an oral disclosure, use, exhibition or other means

"P" document published prior to the international filing date but later than the priority date claimed

"T" later document published after the international filing date or priority date and not in conflict with the application but cited to understand the principle or theory underlying the invention

"X" document of particular relevance; the claimed invention cannot be considered novel or cannot be considered to involve an inventive step when the document is taken alone

"Y" document of particular relevance; the claimed invention cannot be considered to involve an inventive step when the document is combined with one or more other such documents, such combination being obvious to a person skilled in the art

"&" document member of the same patent family

Date of the actual completion of the international search

29 MAY 2009 (29.05.2009)

Date of mailing of the international search report

01 JUNE 2009 (01.06.2009)

Name and mailing address of the ISA/KR

Korean Intellectual Property Office
Government Complex-Daejeon, 139 Seonsa-ro, Seo-
gu, Daejeon 302-701, Republic of Korea

Facsimile No. 82-42-472-7140

Authorized officer

NAM, Yun Kwon

Telephone No. 82-42-481-8357



INTERNATIONAL SEARCH REPORT

Information on patent family members

International application No.

PCT/KR2008/007392

Patent document cited in search report	Publication date	Patent family member(s)	Publication date		
WO 9523440 A1	31.08.1995	AT 202658 E	15.07.2001		
		AU 199517155 A1	11.09.1995		
		CA 02184080 A1	31.08.1995		
		CN 1075253 C	21.11.2001		
		CN 1144019 A	26.02.1997		
		DE 69521497 C0	02.08.2001		
		DE 69521497 T2	29.05.2002		
		DK 746880 T3	07.01.2002		
		EP 0746880 B1	27.06.2001		
		EP 0746880 A1	11.12.1996		
		ES 2160698 T3	16.11.2001		
		GB 2301486 A1	04.12.1996		
		GB 2301486 B2	08.07.1998		
		GB 9409692 A0	06.07.1994		
		GB 9617974 A0	09.10.1996		
		GR 3036740 T3	31.12.2001		
		JP 10500261 A	06.01.1998		
		KR 1019977001435 A	17.03.1997		
		KR 100342111 B1	13.11.2002		
		PT 746880 T	28.12.2001		
-----	-----	-----	-----		
WO 03017424 A1	27.02.2003	AU 200107091 A4	06.09.2001		
		CN 1555593 A	15.12.2004		
-----	-----	-----	-----		
US 3754271 A	21.08.1973	None			
-----	-----	-----	-----		
US 5258768 A	02.11.1993	None			
-----	-----	-----	-----		
WO 2008069358 A1	12.06.2008	KR 100801030 B1	29.01.2008		
		KR 1020080053156 A	12.06.2008		
		KR 1020080053157 A	12.06.2008		
		KR 1020080053159 A	12.06.2008		
		KR 1020080053196 A	12.06.2008		
		KR 1020080053249 A	12.06.2008		
		KR 1020080056131 A	20.06.2008		
		KR 1020080056132 A	20.06.2008		
		KR 1020080056133 A	20.06.2008		
		KR 1020080071952 A	05.08.2008		
		KR 1020080071953 A	05.08.2008		
		KR 1020080072609 A	06.08.2008		
		KR 1020080072610 A	06.08.2008		
		KR 1020080072611 A	06.08.2008		
		KR 1020080077885 A	26.08.2008		
		KR 100865956 B1	30.10.2008		
		KR 1020080100802 A	19.11.2008		
		EP 1930982 A1	11.06.2008		
		-----	-----	-----	-----