



INTERNATIONAL APPLICATION PUBLISHED UNDER THE PATENT COOPERATION TREATY (PCT)

<p>(51) International Patent Classification ⁶ : G06F 9/38, 9/46</p>	<p>A1</p>	<p>(11) International Publication Number: WO 99/21081 (43) International Publication Date: 29 April 1999 (29.04.99)</p>
<p>(21) International Application Number: PCT/US98/21716 (22) International Filing Date: 14 October 1998 (14.10.98) (30) Priority Data: 08/958,716 23 October 1997 (23.10.97) US (71) Applicant: INTERNATIONAL BUSINESS MACHINES CORPORATION [US/US]; New Orchard Road, Armonk, NY 10504 (US). (72) Inventors: BORKENHAGEN, John, Michael; 1359 Westhill Drive S.W., Rochester, MN 55902 (US). EICKEMEYER, Richard, James; 5277 Howard Street N.W., Rochester, MN 55901 (US). FLYNN, William, Thomas; 2516 14th Avenue S.W., Rochester, MN 55902 (US). LEVENSTEIN, Sheldon, Bernard; 1608 7th Street N.E., Rochester, MN 55906 (US). WOTTRENG, Andrew, Henry; 4224 Manor View Drive N.W., Rochester, MN 55901 (US). (74) Agents: OJANEN, Karuna et al.; IBM Corporation, Dept. 917, Building 006-1, 3605 Highway 52 North, Rochester, MN 55901-7829 (US).</p>		<p>(81) Designated States: CA, CN, CZ, HU, IL, JP, KR, PL, RU, European patent (AT, BE, CH, CY, DE, DK, ES, FI, FR, GB, GR, IE, IT, LU, MC, NL, PT, SE). Published <i>With international search report. Before the expiration of the time limit for amending the claims and to be republished in the event of the receipt of amendments.</i></p>

(54) Title: METHOD AND APPARATUS FOR SELECTING THREAD SWITCH EVENTS IN A MULTITHREADED PROCESSOR

(57) Abstract

A system and method for performing computer processing operations in a data processing system (10) includes a multithreaded processor (100) and thread switch logic (400). The multithreaded processor is capable of switching between two or more threads of instructions which can be independently executed. Each thread has a corresponding state in a thread state register (440) depending on its execution status. The thread switch logic contains a thread switch control register (410) to store the conditions upon which a thread will occur. The thread switch logic has a time-out register (430) which forces a thread switch when execution of the active thread in the multithreaded processor exceeds a programmable period of time. Thread switch logic also has a forward progress count register (420) to prevent repetitive thread switching between threads in the multithreaded processor. Thread switch logic also is responsive to a software manager (460) capable of changing the priority of the different threads and thus superseding thread switch events.

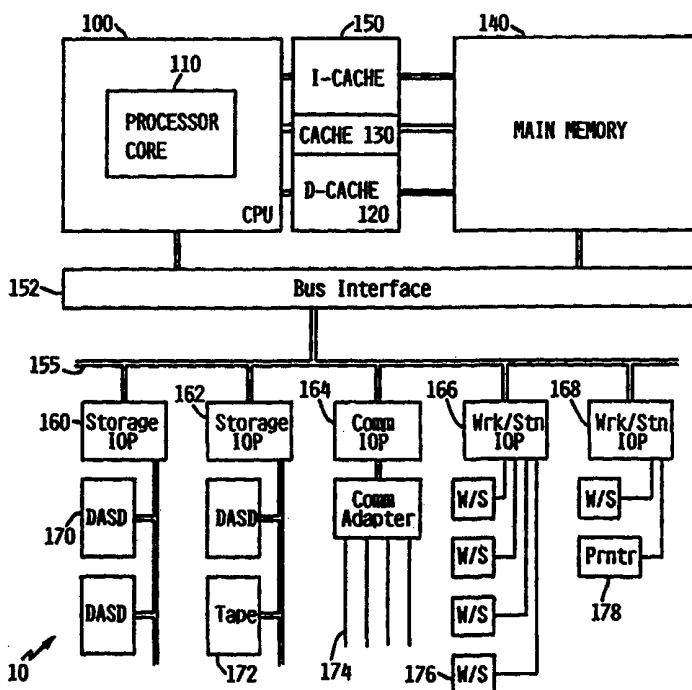

FOR THE PURPOSES OF INFORMATION ONLY

Codes used to identify States party to the PCT on the front pages of pamphlets publishing international applications under the PCT.

AL	Albania	ES	Spain	LS	Lesotho	SI	Slovenia
AM	Armenia	FI	Finland	LT	Lithuania	SK	Slovakia
AT	Austria	FR	France	LU	Luxembourg	SN	Senegal
AU	Australia	GA	Gabon	LV	Latvia	SZ	Swaziland
AZ	Azerbaijan	GB	United Kingdom	MC	Monaco	TD	Chad
BA	Bosnia and Herzegovina	GE	Georgia	MD	Republic of Moldova	TG	Togo
BB	Barbados	GH	Ghana	MG	Madagascar	TJ	Tajikistan
BE	Belgium	GN	Guinea	MK	The former Yugoslav Republic of Macedonia	TM	Turkmenistan
BF	Burkina Faso	GR	Greece	ML	Mali	TR	Turkey
BG	Bulgaria	HU	Hungary	MN	Mongolia	TT	Trinidad and Tobago
BJ	Benin	IE	Ireland	MR	Mauritania	UA	Ukraine
BR	Brazil	IL	Israel	MW	Malawi	UG	Uganda
BY	Belarus	IS	Iceland	MX	Mexico	US	United States of America
CA	Canada	IT	Italy	NE	Niger	UZ	Uzbekistan
CF	Central African Republic	JP	Japan	NL	Netherlands	VN	Viet Nam
CG	Congo	KE	Kenya	NO	Norway	YU	Yugoslavia
CH	Switzerland	KG	Kyrgyzstan	NZ	New Zealand	ZW	Zimbabwe
CI	Côte d'Ivoire	KP	Democratic People's Republic of Korea	PL	Poland		
CM	Cameroon	KR	Republic of Korea	PT	Portugal		
CN	China	KZ	Kazakstan	RO	Romania		
CU	Cuba	LC	Saint Lucia	RU	Russian Federation		
CZ	Czech Republic	LI	Liechtenstein	SD	Sudan		
DE	Germany	LK	Sri Lanka	SE	Sweden		
DK	Denmark	LR	Liberia	SG	Singapore		
EE	Estonia						

DescriptionMethod and Apparatus for Selecting Thread Switch
Events in a Multithreaded ProcessorRelated Application Data

5 The present invention relates to the following U.S. patent
applications, the subject matter of which is hereby
incorporated by reference: (1) U.S. application entitled
Thread Switch Control in a Multithreaded Processor System,
Serial Number 08/957,002 filed 23 October 1997 concurrently
10 herewith; (2) U.S. application entitled *An Apparatus and Method
to Guarantee Forward Progress in a Multithreaded Processor*,
Serial Number 08/956,875 filed 23 October 1997 concurrently
herewith; (3) U.S. application entitled *Altering Thread
Priorities in a Multithreaded Processor*, Serial Number
15 08/958,718, filed 23 October 1997 concurrently herewith; (4)
U.S. application entitled *Method and Apparatus to Force a
Thread Switch in a Multithreaded Processor*, Serial Number
08/956,577 filed 23 October 1997 concurrently herewith; (5)
U.S. application entitled *Background Completion of Instruction
and Associated Fetch Request in a Multithread Processor*, Serial
20 Number 773,572 filed 27 December 1996; (6) U.S. application
entitled *Multi-Entry Fully Associative Transition Cache*, Serial
Number 761,378 filed 09 December 1996; (7) U.S. application
entitled *Method and Apparatus for Prioritizing and Routing
Commands from a Command Source to a Command Sink*, Serial Number
25 761,380 filed 09 December 1996; (8) U.S. application entitled
Method and Apparatus for Tracking Processing of a Command,
Serial Number 761,379 filed 09 December 1996; (9) U.S.
application entitled *Method and System for Enhanced Multithread
Operation in a Data Processing System by Reducing Memory Access
Latency Delays*, Serial Number 473,692 filed 7 June 1995; and
30 (10) U.S. Patent 5,778,243 entitled *Multithreaded Cell for a
Memory*, issued 07 July 1998.

Background of the Invention

The present invention relates in general to an improved method for and apparatus of a computer data processing system; and in particular, to an improved high performance
5 multithreaded computer data processing system and method embodied in the hardware of the processor.

The fundamental structure of a modern computer includes peripheral devices to communicate information to and from the outside world; such peripheral devices may be keyboards,
10 monitors, tape drives, communication lines coupled to a network, etc. Also included in the basic structure of the computer is the hardware necessary to receive, process, and deliver this information from and to the outside world, including busses, memory units, input/output (I/O) controllers,
15 storage devices, and at least one central processing unit (CPU), etc. The CPU is the brain of the system. It executes the instructions which comprise a computer program and directs the operation of the other system components.

From the standpoint of the computer's hardware, most
20 systems operate in fundamentally the same manner. Processors actually perform very simple operations quickly, such as arithmetic, logical comparisons, and movement of data from one location to another. Programs which direct a computer to perform massive numbers of these simple operations give the
25 illusion that the computer is doing something sophisticated. What is perceived by the user as a new or improved capability of a computer system, however, may actually be the machine performing the same simple operations, but much faster. Therefore continuing improvements to computer systems require
30 that these systems be made ever faster.

One measurement of the overall speed of a computer system, also called the throughput, is measured as the number of operations performed per unit of time. Conceptually, the simplest of all possible improvements to system speed is to
35 increase the clock speeds of the various components, particularly the clock speed of the processor. So that if everything runs twice as fast but otherwise works in exactly

the same manner, the system will perform a given task in half the time. Computer processors which were constructed from discrete components years ago performed significantly faster by shrinking the size and reducing the number of components; eventually the entire processor was packaged as an integrated circuit on a single chip. The reduced size made it possible to increase the clock speed of the processor, and accordingly increase system speed.

Despite the enormous improvement in speed obtained from integrated circuitry, the demand for ever faster computer systems still exists. Hardware designers have been able to obtain still further improvements in speed by greater integration, by further reducing the size of the circuits, and by other techniques. Designer, however, think that physical size reductions cannot continue indefinitely and there are limits to continually increasing processor clock speeds. Attention has therefore been directed to other approaches for further improvements in overall speed of the computer system.

Without changing the clock speed, it is still possible to improve system speed by using multiple processors. The modest cost of individual processors packaged on integrated circuit chips has made this practical. The use of slave processors considerably improves system speed by off-loading work from the CPU to the slave processor. For instance, slave processors routinely execute repetitive and single special purpose programs, such as input/output device communications and control. It is also possible for multiple CPUs to be placed in a single computer system, typically a host-based system which services multiple users simultaneously. Each of the different CPUs can separately execute a different task on behalf of a different user, thus increasing the overall speed of the system to execute multiple tasks simultaneously. It is much more difficult, however, to improve the speed at which a single task, such as an application program, executes. Coordinating the execution and delivery of results of various functions among multiple CPUs is a tricky business. For slave I/O processors this is not so difficult because the functions

are pre-defined and limited but for multiple CPUs executing general purpose application programs it is much more difficult to coordinate functions because, in part, system designers do not know the details of the programs in advance. Most application programs follow a single path or flow of steps performed by the processor. While it is sometimes possible to break up this single path into multiple parallel paths, a universal application for doing so is still being researched. Generally, breaking a lengthy task into smaller tasks for parallel processing by multiple processors is done by a software engineer writing code on a case-by-case basis. This ad hoc approach is especially problematic for executing commercial transactions which are not necessarily repetitive or predictable.

Thus, while multiple processors improve overall system performance, there are still many reasons to improve the speed of the individual CPU. If the CPU clock speed is given, it is possible to further increase the speed of the CPU, i.e., the number of operations executed per second, by increasing the **average** number of operations executed per clock cycle. A common architecture for high performance, single-chip microprocessors is the reduced instruction set computer (RISC) architecture characterized by a small simplified set of frequently used instructions for rapid execution, those simple operations performed quickly mentioned earlier. As semiconductor technology has advanced, the goal of RISC architecture has been to develop processors capable of executing one or more instructions on each clock cycle of the machine. Another approach to increase the **average** number of operations executed per clock cycle is to modify the hardware within the CPU. This throughput measure, clock cycles per instruction, is commonly used to characterize architectures for high performance processors. Instruction pipelining and cache memories are computer architectural features that have made this achievement possible. Pipeline instruction execution allows subsequent instructions to begin execution before previously issued instructions have finished. Cache memories

store frequently used and other data nearer the processor and allow instruction execution to continue, in most cases, without waiting the full access time of a main memory. Some improvement has also been demonstrated with multiple execution
5 units with look ahead hardware for finding instructions to execute in parallel.

The performance of a conventional RISC processor can be further increased in the superscalar computer and the Very Long Instruction Word (VLIW) computer, both of which execute more
10 than one instruction in parallel per processor cycle. In these architectures, multiple functional or execution units are provided to run multiple pipelines in parallel. In a superscalar architecture, instructions may be completed in-order and out-of-order. In-order completion means no
15 instruction can complete before all instructions dispatched ahead of it have been completed. Out-of-order completion means that an instruction is allowed to complete before all instructions ahead of it have been completed, as long as a predefined rules are satisfied.

For both in-order and out-of-order execution in
20 superscalar systems, pipelines will stall under certain circumstances. An instruction that is dependent upon the results of a previously dispatched instruction that has not yet completed may cause the pipeline to stall. For instance,
25 instructions dependent on a load/store instruction in which the necessary data is not in the cache, i.e., a cache miss, cannot be executed until the data becomes available in the cache. Maintaining the requisite data in the cache necessary for continued execution and to sustain a high hit ratio, i.e., the
30 number of requests for data compared to the number of times the data was readily available in the cache, is not trivial especially for computations involving large data structures. A cache miss can cause the pipelines to stall for several
35 cycles, and the total amount of memory latency will be severe if the data is not available most of the time. Although memory devices used for main memory are becoming faster, the speed gap between such memory chips and high-end processors is becoming

increasingly larger. Accordingly, a significant amount of execution time in current high-end processor designs is spent waiting for resolution of cache misses and these memory access delays use an increasing proportion of processor execution time.

And yet another technique to improve the efficiency of hardware within the CPU is to divide a processing task into independently executable sequences of instructions called threads. This technique is related to breaking a larger task into smaller tasks for independent execution by different processors except here the threads are to be executed by the same processor. When a CPU then, for any of a number of reasons, cannot continue the processing or execution of one of these threads, the CPU switches to and executes another thread.

This is the subject of the invention described herein which incorporates hardware multithreading to tolerate memory latency. The term "multithreading" as defined in the computer architecture community is not the same as the software use of the term which means one task subdivided into multiple related threads. In the architecture definition, the threads may be independent. Therefore "hardware multithreading" is often used to distinguish the two uses of the term. The present invention incorporates the term multithreading to connote hardware multithreading.

Multithreading permits the processors' pipeline(s) to do useful work on different threads when a pipeline stall condition is detected for the current thread. Multithreading also permits processors implementing non-pipeline architectures to do useful work for a separate thread when a stall condition is detected for a current thread. There are two basic forms of multithreading. A traditional form is to keep N threads, or states, in the processor and interleave the threads on a cycle-by-cycle basis. This eliminates all pipeline dependencies because instructions in a single thread are separated. The other form of multithreading, and the one considered by the present invention, is to interleave the threads on some long-latency event.

Traditional forms of multithreading involves replicating the processor registers for each thread. For instance, for a processor implementing the architecture sold under the trade name PowerPC™ to perform multithreading, the processor must maintain N states to run N threads. Accordingly, the following are replicated N times: general purpose registers, floating point registers, condition registers, floating point status and control register, count register, link register, exception register, save/restore registers, and special purpose registers. Additionally, the special buffers, such as a segment lookaside buffer, can be replicated or each entry can be tagged with the thread number and, if not, must be flushed on every thread switch. Also, some branch prediction mechanisms, e.g., the correlation register and the return stack, should also be replicated. Fortunately, there is no need to replicate some of the larger functions of the processor such as: level one instruction cache (L1 I-cache), level one data cache (L1 D-cache), instruction buffer, store queue, instruction dispatcher, functional or execution units, pipelines, translation lookaside buffer (TLB), and branch history table. When one thread encounters a delay, the processor rapidly switches to another thread. The execution of this thread overlaps with the memory delay on the first thread.

Existing multithreading techniques describe switching threads on a cache miss or a memory reference. A primary example of this technique may be reviewed in "Sparcle: An Evolutionary Design for Large-Scale Multiprocessors," by Agarwal et al., IEEE Micro Volume 13, No. 3, pp. 48-60, June 1993. As applied in a RISC architecture, multiple register sets normally utilized to support function calls are modified to maintain multiple threads. Eight overlapping register windows are modified to become four non-overlapping register sets, wherein each register set is a reserve for trap and message handling. This system discloses a thread switch which occurs on each first level cache miss that results in a remote memory request. While this system represents an advance in the

art, modern processor designs often utilize a multiple level cache or high speed memory which is attached to the processor. The processor system utilizes some well-known algorithm to decide what portion of its main memory store will be loaded within each level of cache and thus, each time a memory reference occurs which is not present within the first level of cache the processor must attempt to obtain that memory reference from a second or higher level of cache.

It is thus an object of the invention to provide an improved data processing system which can reduce delays due to memory latency in a multilevel cache system utilizing hardware logic and registers embodied in a multithread data processing system.

Summary of the Invention

The invention addresses this object by providing a multithreaded processor capable of switching execution between two threads of instructions, and thread switch logic embodied in hardware registers with optional software override of thread switch conditions. Processing various states of various threads of instructions allows optimization of the use of the processor among the threads. Allowing the processor to execute a second thread of instructions increases processor utilization which is otherwise idle when it is retrieving necessary data and/or instructions from various memory elements, such as caches, memories, external I/O, direct access storage devices for a first thread. The conditions of thread switching can be different per thread or can be changed during processing by the use of a software thread control manager.

The invention provides a hardware thread switch control register containing bits which can be enabled to embody the events and cause a multithreaded processor to switch threads. This hardware register has the further advantage of improving processor performance because it is much faster than software thread switch control.

Another aspect of the invention is a computer system having a multithreaded processor capable of switching

processing between at least two threads of instructions when the multithreaded processor experiences one of a plurality of processor latency events. The computer system also has at least one thread state register operatively connected to the multithreaded processor, to store a state of the threads of instructions wherein the state of each thread of instructions changes when the processor switches processing to each thread. The system also has at least one thread switch control register operatively connected to the thread state register(s) and to the multithreaded processor, to store a plurality of thread switch control events which thread switch control events are enabled by setting a corresponding plurality of enable bits. The computer system further comprises a plurality of internal connections connecting the multithreaded processor to a plurality of memory elements. Access to any of the memory elements by the multithreaded processor causes a processor latency event and the invention also has at least one external connection connecting the multithreaded processor to an external memory device, a communication device, a computer network, or an input/output device wherein access to any of the devices or the network by the multithreaded processor also causes a plurality of processor latency events. When one of the threads executing in the multithreaded processor is unable to continue execution because of one of the processor latency events and when that processor latency event is a thread switch control event whose bit is enabled, the multithreaded processor switches execution to another of the threads.

The thread switch control register has a plurality of bits, each associated uniquely with one of a plurality of thread switch control events and if one of the bits is enabled, the thread switch control event associated with that bit causes the multithreaded processor(s) to switch from one thread of instructions to another thread of instructions. The thread switch control register is programmable. Moreover, the enablement of a particular bit can be dynamically changed by either operating software or by an instruction in one of the threads.

The computer processing system may have more than one thread switch control register wherein the bit values of one thread switch control register differs from the bit values of another of said thread switch control registers.

5 Typically, there can be many thread switch control events, for instance, a data miss from at least one of the following: a L1-data cache, a L2 cache, storage of data that crosses a double word boundary, or an instruction miss from at least one of the following: a L1-instruction cache, a translation
10 lookaside buffer, or a data and/or instruction miss from main memory, or an error in address translation of data and/or an instruction. Access to an I/O device external to the processor or to another processor may also be thread switch control events. Other thread switch control events comprise a forward
15 progress count of a number of times said one of a plurality of threads has been switched from a one multithreaded processor with no instruction of the one of a plurality of threads executing, and a time-out period in which no useful work was done by the at least one processor.

20 The computer processing system of the invention comprises means for processing a plurality of threads of instructions; means for indicating when the processing means stalls because one of the threads experiences a processor latency event; means for registering a plurality of thread switch control events; and means for determining if the processor latency event is one
25 of the plurality of thread switch control events. The processing system may also comprise means for enabling the processing means to switch processing to another thread if the processor latency event is a thread switch control event.

30 The invention is also a method to determine the contents of a thread switch control register, comprising the steps of counting a first number of processor cycles in which a multithreaded processor is stalled because of processor latency event and counting a second number of processor cycles required
35 for the multithreaded processor to switch processing of a first thread of instructions to a second thread of instructions, then assigning the processor latency event to be a thread switch

control event by setting an enable bit in the thread switch control register if the first number is greater than the second number. Then if the enable bit is enabled, the method comprises outputting a signal to switch threads when the
5 multithreaded processor experiences the thread switch control event if the enable bit is enabled.

The method of computer processing of the invention also comprises the steps of storing a state of a thread in a thread state register and storing a plurality of thread switch control
10 events in a thread switch control register. Then when the state of the thread changes, a signal is output to the thread state register and the changed state of the thread is compared with the plurality of thread switch control events. If the changed state results from a thread switch control event, a
15 signal is output to a multithreaded processor to switch execution from the thread.

Other objects, features and characteristics of the present invention; methods, operation, and functions of the related elements of the structure; combination of parts; and economies
20 of manufacture will become apparent from the following detailed description of the preferred embodiments and accompanying drawings, all of which form a part of this specification, wherein like reference numerals designate corresponding parts in the various figures.

25 Brief Description of the Drawings

The invention itself, however, as well as a preferred mode of use, further objectives and advantages thereof, will best be understood by reference to the following detailed description of an illustrative embodiment when read in
30 conjunction with the accompanying drawings, wherein:

Figure 1 is a block diagram of a computer system capable of implementing the invention described herein.

Figure 2 illustrates a high level block diagram of a multithreaded data processing system according to the present
35 invention.

Figure 3 illustrates a block diagram of the storage control unit of Figure 2.

Figure 4 illustrates a block diagram of the thread switch logic, the storage control unit and the instruction unit of Figure 2.

Figure 5 illustrate the changes of state of a thread as the thread experiences different thread switch events shown in Figure 4.

Figure 6 is a flow chart of the forward progress count of the invention.

Detailed Description of the Preferred Embodiments

With reference now to the figures and in particular with reference to Figure 1, there is depicted a high level block diagram of a computer data processing system 10 which may be utilized to implement the method and system of the present invention. The primary hardware components and interconnections of a computer data processing system 10 capable of utilizing the present invention are shown in Figure 1. Central processing unit (CPU) 100 for processing instructions is coupled to caches 120, 130, and 150. Instruction cache 150 stores instructions for execution by CPU 100. Data caches 120, 130 store data to be used by CPU 100. The caches communicate with random access memory in main memory 140. CPU 100 and main memory 140 also communicate via bus interface 152 with system bus 155. Various input/output processors (IOPs) 160-168 attach to system bus 155 and support communication with a variety of storage and input/output (I/O) devices, such as direct access storage devices (DASD) 170, tape drives 172, remote communication lines 174, workstations 176, and printers 178. It should be understood that Figure 1 is intended to depict representative components of a computer data processing system 10 at a high level, and that the number and types of such components may vary.

Within the CPU 100, a processor core 110 contains specialized functional units, each of which perform primitive operations, such as sequencing instructions, executing

operations involving integers, executing operations involving real numbers, transferring values between addressable storage and logical register arrays. Figure 2 illustrates a processor core 100. In a preferred embodiment, the processor core 100 of the data processing system 10 is a single integrated circuit, pipelined, superscalar microprocessor, which may be implemented utilizing any computer architecture such as the family of RISC processors sold under the trade name PowerPC™; for example, the PowerPC™ 604 microprocessor chip sold by IBM.

As will be discussed below, the data processing system 10 preferably includes various units, registers, buffers, memories, and other sections which are all preferably formed by integrated circuitry. It should be understood that in the figures, the various data paths have been simplified; in reality, there are many separate and parallel data paths into and out of the various components. In addition, various components not germane to the invention described herein have been omitted, but it is to be understood that processors contain additional units for additional functions. The data processing system 10 can operate according to reduced instruction set computing, RISC, techniques or other computing techniques.

As represented in Figure 2, the processor core 100 of the data processing system 10 preferably includes a level one data cache, L1 D-cache 120, a level two L2 cache 130, a main memory 140, and a level one instruction cache, L1 I-cache 150, all of which are operationally interconnected utilizing various bus connections to a storage control unit 200. As shown in Figure 1, the storage control unit 200 includes a transition cache 210 for interconnecting the L1 D-cache 120 and the L2 cache 130, the main memory 140, and a plurality of execution units. The L1 D-cache 120 and L1 I-cache 150 preferably are provided on chip as part of the processor 100 while the main memory 140 and the L2 cache 130 are provided off chip. Memory system 140 is intended to represent random access main memory which may or may not be within the processor core 100 and, and other data buffers and caches, if any, external to the processor core 100,

and other external memory, for example, DASD 170, tape drives 172, and workstations 176, shown in Figure 1. The L2 cache 130 is preferably a higher speed memory system than the main memory 140, and by storing selected data within the L2 cache 130, the memory latency which occurs as a result of a reference to the main memory 140 can be minimized. As shown in Figure 1, the L2 cache 130 and the main memory 140 are directly connected to both the L1 I-cache 150 and an instruction unit 220 via the storage control unit 200.

Instructions from the L1 I-cache 150 are preferably output to an instruction unit 220 which, in accordance with the method and system of the present invention, controls the execution of multiple threads by the various subprocessor units, e.g., branch unit 260, fixed point unit 270, storage control unit 200, and floating point unit 280 and others as specified by the architecture of the data processing system 10. In addition to the various execution units depicted within Figure 1, those skilled in the art will appreciate that modern superscalar microprocessor systems often include multiple versions of each such execution unit which may be added without departing from the spirit and scope of the present invention. Most of these units will have as an input source operand information from various registers such as general purpose registers GPRs 272, and floating point registers FPRs 282. Additionally, multiple special purpose register SPRs 274 may be utilized. As shown in Figure 2, the storage control unit 200 and the transition cache 210 are directly connected to general purpose registers 272 and the floating point registers 282. The general purpose registers 272 are connected to the special purpose registers 274.

Among the functional hardware units unique to this multithreaded processor 100 is the thread switch logic 400 and the transition cache 210. The thread switch logic 400 contains various registers that determine which thread will be the active or the executing thread. Thread switch logic 400 is operationally connected to the storage control unit 200, the execution units 260, 270, and 280, and the instruction unit

220. The transition cache 210 within the storage control unit 200 must be capable of implementing multithreading. Preferably, the storage control unit 200 and the transition cache 210 permit at least one outstanding data request per thread. Thus, when a first thread is suspended in response to, for example, the occurrence of L1 D-cache miss, a second thread would be able to access the L1 D-cache 120 for data present therein. If the second thread also results in L1 D-cache miss, another data request will be issued and thus multiple data requests must be maintained within the storage control unit 200 and the transition cache 210. Preferably, transition cache 210 is the transition cache of U.S. Application Serial Number 08/761,378 filed 09 December 1996 entitled *Multi-Entry Fully Associative Transition Cache*, hereby incorporated by reference. The storage control unit 200, the execution units 260, 270, and 280 and the instruction unit 220 are all operationally connected to the thread switch logic 400 which determines which thread to execute.

As illustrated in Figure 2, a bus 205 is provided between the storage control unit 200 and the instruction unit 220 for communication of, e.g., data requests to the storage control unit 200, and a L2 cache 130 miss to the instruction unit 220. Further, a translation lookaside buffer TLB 250 is provided which contains virtual-to-real address mapping. Although not illustrated within the present invention various additional high level memory mapping buffers may be provided such as a segment lookaside buffer which will operate in a manner similar to the translation lookaside buffer 250.

Figure 3 illustrates the storage control unit 200 in greater detail, and, as the name implies, this unit controls the input and output of data and instructions from the various storage units, which include the various caches, buffers and main memory. As shown in Figure 3, the storage control unit 200 includes the transition cache 210 functionally connected to the L1 D-cache 120, multiplexer 360, the L2 cache 130, and main memory 140. Furthermore, the transition cache 210 receives control signals from sequencers 350. The sequencers

350 include a plurality of sequencers, preferably three, for handling instruction and/or data fetch requests. Sequencers 350 also output control signals to the transition cache 210, the L2 cache 130, as well as receiving and transmitting control signals to and from the main memory 140.

Multiplexer 360 in the storage control unit 200 shown in Figure 3 receives data from the L1 D-cache 120, the transition cache 210, the L2 cache 130, main memory 140, and, if data is to be stored to memory, the execution units 270 and 280. Data from one of these sources is selected by the multiplexer 360 and is output to the L1 D-cache 120 or the execution units in response to a selection control signal received from the sequencers 350. Furthermore, as shown in Figure 3, the sequencers 350 output a selection signal to control a second multiplexer 370. Based on this selection signal from the sequencers 350, the multiplexer 370 outputs the data from the L2 cache 130 or the main memory 140 to the L1 I-cache 150 or the instruction unit 220. In producing the above-discussed control and selection signals, the sequencers 350 access and update the L1 directory 320 for the L1 D-cache 120 and the L2 directory 330 for the L2 cache 130.

With respect to the multithreading capability of the processor described herein, sequencers 350 of the storage control unit 200 also output signals to thread switch logic 400 which indicate the state of data and instruction requests. So, feedback from the caches 120, 130 and 150, main memory 140, and the translation lookaside buffer 250 is routed to the sequencers 350 and is then communicated to thread switch logic 400 which may result in a thread switch, as discussed below. Note that any device wherein an event designed to cause a thread switch in a multithreaded processor occurs will be operationally connected to sequencers 350.

Figure 4 is a logical representation and block diagram of the thread switch logic hardware 400 that determines whether a thread will be switched and, if so, what thread. Storage control unit 200 and instruction unit 220 are interconnected with thread switch logic 400. Thread switch logic 400

preferably is incorporated into the instruction unit 220 but if there are many threads the complexity of the thread switch logic 400 may increase so that the logic is external to the instruction unit 220. For ease of explanation, thread switch logic 400 is illustrated external to the instruction unit 220.

Some events which result in a thread to be switched in this embodiment are communicated on lines 470, 472, 474, 476, 478, 480, 482, 484, and 486 from the sequencers 350 of the storage control unit 200 to the thread switch logic 400. Other latency events can cause thread switching; this list is not intended to be inclusive; rather it is only representative of how the thread switching can be implemented. A request for an instruction by either the first thread *T0* or the second thread *T1* which is not in the instruction unit 220 is an event which can result in a thread switch, noted by 470 and 472 in Figure 4, respectively. Line 474 indicates when the active thread, whether *T0* or *T1*, experiences a L1 D-cache 120 miss. Cache misses of the L2 cache 130 for either thread *T0* or *T1* is noted at lines 476 and 478, respectively. Lines 480 and 482 are activated when data is returned for continued execution of the *T0* thread or for the *T1* thread, respectively. Translation lookaside buffer misses and completion of a table walk are indicated by lines 484 and 486, respectively.

These events are all fed into the thread switch logic 400 and more particularly to the thread state registers 440 and the thread switch controller 450. Thread switch logic 400 has one thread state register for each thread. In the embodiment described herein, two threads are represented so there is a *T0* state register 442 for a first thread *T0* and a *T1* state register 444 for a second thread *T1*, to be described herein. Thread switch logic 400 comprises a thread switch control register 410 which controls what events will result in a thread switch. For instance, the thread switch control register 410 can block events that cause state changes from being seen by the thread switch controller 450 so that a thread may not be switched as a result of a blocked event. The thread state registers and the logic of changing threads are the subject of

U.S. application entitled *Thread Switch Control in a Multithreaded Processor System*, Serial Number 08/957,002 filed 23 October 1997 concurrently herewith and herein incorporated by reference. The forward progress count register 420 is used to prevent thrashing and may be included in the thread switch control register 410. The forward progress count register 420 is the subject of U.S. application entitled *An Apparatus and Method to Guarantee Forward Progress in a Multithreaded Processor*, Serial Number 08/956,875 filed 23 October 1997 concurrently herewith and herein incorporated by reference, RO997-105. Thread switch time-out register 430, the subject of U.S. application entitled *Method and Apparatus to Force a Thread Switch in a Multithreaded Processor*, Serial Number 08/956,577 filed 23 October 1997 concurrently herewith and herein incorporated by reference, RO997-107, allocates fairness and livelock issues. Also, thread priorities can be altered using software 460, the subject of U.S. application entitled *Altering Thread Priorities in a Multithreaded Processor*, Serial Number 08/958,718, filed 23 October 1997 concurrently herewith and herein incorporated by reference, RO997-106. Finally, but not to be limitative, the thread switch controller 450 comprises a myriad of logic gates which represents the culmination of all logic which actually determines whether a thread is switched, what thread, and under what circumstances. Each of these logic components and their functions are set forth in further detail.

Thread State Registers

Thread state registers 440 comprise a state register for each thread and, as the name suggests, store the state of the corresponding thread; in this case, a *T0* thread state register 442 and a *T1* thread state register 444. The number of bits and the allocation of particular bits to describe the state of each thread can be customized for a particular architecture and thread switch priority scheme. An example of the allocation of bits in the thread state registers 442, 444 for a

multithreaded processor having two threads is set forth in the table below.

Thread State Register Bit Allocation

5	(0)	Instruction/Data 0 = Instruction 1 = Data
10	(1:2)	Miss type sequencer 00 = None 01 = Translation lookaside buffer miss (check bit 0 for I/D) 10 = L1 cache miss 11 = L2 cache miss
15	(3)	Transition 0 = Transition to current state does not result in thread switch 1 = Transition to current state results in thread switch
20	(4:7)	Reserved
25	(8)	0 = Load 1 = Store
30	(9:14)	Reserved
35	(15:17)	Forward progress counter 111 = Reset (instruction has completed during this thread) 000 = 1st execution of this thread w/o instruction complete 001 = 2nd execution of this thread w/o instruction complete 010 = 3rd execution of this thread w/o instruction complete 011 = 4th execution of this thread w/o instruction complete 100 = 5th execution of this thread w/o instruction complete
40	(18:19)	Priority (could be set by software) 00 = Medium 01 = Low 10 = High 11 = <Illegal>
	(20:31)	Reserved
	(32:63)	Reserved if 64 bit implementation

In the embodiment described herein, bit 0 identifies whether the miss or the reason the processor stalled execution is a result of a request for an instruction or for data. Bits 1 and 2 indicate if the requested information was not available and if so, from what hardware, i.e., whether the translated address of the data or instruction was not in the translation lookaside buffer 250, or the data or instruction itself was not in the L1 D-cache 120 or the L2 cache 130, as further explained in the description of Figure 5. Bit 3 indicates whether the change of state of a thread results in a thread switch. A thread may change state without resulting in a thread switch. For instance, if a thread switch occurs when thread *T1*

experiences an L1 cache miss, then if thread *T1* experiences a L2 cache miss, there will be no thread switch because the thread already switched on a L1 cache miss. The state of *T1*, however, still changes. Alternatively, if by choice, the thread switch logic 400 is configured or programmed not to switch on a L1 cache miss, then when a thread does experience an L1 cache miss, there will be no thread switch even though the thread changes state. Bit 8 of the thread state registers 442 and 444 is assigned to whether the information requested by a particular thread is to be loaded into the processor core or stored from the processor core into cache or main memory. Bits 15 through 17 are allocated to prevent thrashing, as discussed later with reference to the forward progress count register 420. Bits 18 and 19 can be set in the hardware or could be set by software to indicate the priority of the thread.

Figure 5 represents four states in the present embodiment of a thread processed by the data processing system 10 and these states are stored in the thread state registers 440, bit positions 1:2. State *00* represents the "ready" state, i.e., the thread is ready for processing because all data and instructions required are available; state *10* represents the thread state wherein the execution of the thread within the processor is stalled because the thread is waiting for return of data into either the L1 D-cache 120 or the return of an instruction into the L1 I-cache 150; state *11* represents that the thread is waiting for return of data into the L2 cache 130; and the state *01* indicates that there is a miss on the translation lookaside buffer 250, i.e., the virtual address was in error or wasn't available, called a *table walk*. Also shown in Figure 5 is the hierarchy of thread states wherein state *00*, which indicates the thread is ready for execution, has the highest priority. Short latency events are preferably assigned a higher priority.

Figure 5 also illustrates the change of states when data is retrieved from various sources. The normal uninterrupted execution of a thread *T0* is represented in block 510 as state

00. If a L1 D-cache or I-cache miss occurs, the thread state changes to state 10, as represented in block 512, pursuant to a signal sent on line 474 (Figure 4) from the storage control unit 200 or line 470 (Figure 4) from the instruction unit 220, respectively. If the required data or instruction is in the L2 cache 130 and is retrieved, then normal execution of T0 resumes at block 510. Similarly block 514 of Figure 5 represents a L2 cache miss which changes the state of thread of either T0 or T1 to state 11 when storage control unit 200 signals the miss on lines 476 or 478 (Figure 4). When the instructions or data in the L2 cache are retrieved from main memory 140 and loaded into the processor core 100 as indicated on lines 480 and 482 (Figure 4), the state again changes back to state 00 at block 510. The storage control unit 200 communicates to the thread registers 440 on line 484 (Figure 4) when the virtual address for requested information is not available in the translation lookaside buffer 250, indicated as block 516, as a TLB miss or state 01. When the address does become available or if there is a data storage interrupt instruction as signaled by the storage control unit 200 on line 486 (Figure 4), the state of the thread then returns to state 00, meaning ready for execution.

The number of states, and what each state represents is freely selectable by the computer architect. For instance, if a thread has multiple L1 cache misses, such as both a L1 I-cache miss and L1 D-cache miss, a separate state can be assigned to each type of cache miss. Alternatively, a single thread state could be assigned to represent more than one event or occurrence. An example of a thread switch algorithm for two threads of equal priority which determines whether to switch threads is given. The algorithm can be expanded and modified accordingly for more threads and thread switch conditions according to the teachings of the invention. The interactions between the state of each thread stored in the thread state registers 440 (Figure 4) and the priority of each thread by the thread switching algorithm are dynamically interrogated each cycle. If the active thread T0 has a L1

miss, the algorithm will cause a thread switch to the dormant thread *T1* unless the dormant thread *T1* is waiting for resolution of a L2 miss. If a switch did not occur and the L1 cache miss of active thread *T0* turns into a L2 cache miss, the
5 algorithm then directs the processor to switch to the dormant thread *T1* regardless of the *T1*'s state. If both threads are waiting for resolution of a L2 cache miss, the thread first having the L2 miss being resolved becomes the active thread. At every switch decision time, the action taken is optimized
10 for the most likely case, resulting in the best performance. Note that thread switches resulting from a L2 cache miss are conditional on the state of the other thread, if not extra thread switches would occur resulting in loss of performance.

Thread Switch Control Register

15 In any multithreaded processor, there are latency and performance penalties associated with switching threads. In the multithreaded processor in the preferred embodiment described herein, this latency includes the time required to complete execution of the current thread to a point where it
20 can be interrupted and correctly restarted when it is next invoked, the time required to switch the thread-specific hardware facilities from the current thread's state to the new thread's state, and the time required to restart the new thread and begin its execution. Preferably the thread-specific
25 hardware facilities operable with the invention include the thread state registers described above and the memory cells described in U.S. Patent 5,778,243 entitled *Multithreaded Cell for a Memory*, herein incorporated by reference. In order to achieve optimal performance in a coarse grained multithreaded
30 data processing system, the latency of an event which generates a thread switch must be greater than the performance cost associated with switching threads in a multithreaded mode, as opposed to the normal single-threaded mode.

35 The latency of an event used to generate a thread switch is dependent upon both hardware and software. For example, specific hardware considerations in a multithreaded processor

include the speed of external SRAMs used to implement an L2 cache external to the processor chip. Fast SRAMs in the L2 cache reduce the average latency of an L1 miss while slower SRAMs increase the average latency of an L1 miss. Thus, performance is gained if one thread switch event is defined as a L1 cache miss in hardware having an external L2 cache data access latency greater than the thread switch penalty. As an example of how specific software code characteristics affect the latency of thread switch events, consider the L2 cache hit-to-miss ratio of the code, i.e., the number of times data is actually available in the L2 cache compared to the number of times data must be retrieved from main memory because data is not in the L2 cache. A high L2 hit-to-miss ratio reduces the average latency of an L1 cache miss because the L1 cache miss seldom results in a longer latency L2 miss. A low L2 hit-to-miss ratio increases the average latency of an L1 miss because more L1 misses result in longer latency L2 misses. Thus, a L1 cache miss could be disabled as a thread switch event if the executing code has a high L2 hit-to-miss ratio because the L2 cache data access latency is less than the thread switch penalty. A L1 cache miss would be enabled as a thread switch event when executing software code with a low L2 hit-to-miss ratio because the L1 cache miss is likely to turn into a longer latency L2 cache miss.

Some types of latency events are not readily detectable. For instance, in some systems the L2 cache outputs a signal to the instruction unit when a cache miss occurs. Other L2 caches, however, do not output such a signal, as in for example, if the L2 cache controller were on a separate chip from the processor and accordingly, the processor cannot readily determine a state change. In these architectures, the processor can include a cycle counter for each outstanding L1 cache miss. If the miss data has not been returned from the L2 cache after a predetermined number of cycles, the processor acts as if there had been a L2 cache miss and changes the thread's state accordingly. This algorithm is also applicable to other cases where there are more than one distinct type of

latency. As an example only, for a L2 cache miss in a multiprocessor, the latency of data from main memory may be significantly different than the latency of data from another processor. These two events may be assigned different states in the thread state register. If no signal exists to distinguish the states, a counter may be used to estimate which state the thread should be in after it encounters a L2 cache miss.

The thread switch control register 410 is a software programmable register which selects the events to generate thread switching and has a separate enable bit for each defined thread switch control event. Although the embodiment described herein does not implement a separate thread switch control register 410 for each thread, separate thread switch control registers 410 for each thread could be implemented to provide more flexibility and performance at the cost of more hardware and complexity. Moreover, the thread switch control events in one thread switch control register need not be identical to the thread switch control events in any other thread switch control register.

The thread switch control register 410 can be written by a service processor with software such as a dynamic scan communications interface disclosed in U.S. Patent No. 5,079,725 entitled *Chip Identification Method for Use with Scan Design Systems and Scan Testing Techniques* or by the processor itself with software system code. The contents of the thread switch control register 410 is used by the thread switch controller 450 to enable or disable the generation of a thread switch. A value of one in the register 410 enables the thread switch control event associated with that bit to generate a thread switch. A value of zero in the thread switch control register 410 disables the thread switch control event associated with that bit from generating a thread switch. Of course, an instruction in the executing thread could disable any or all of the thread switch conditions for that particular or for other threads. The following table shows the association

between thread switch events and their enable bits in the register 410.

Thread Switch Control Register Bit Assignment

5	(0)	Switch on L1 data cache fetch miss
	(1)	Switch on L1 data cache store miss
	(2)	Switch on L1 instruction cache miss
	(3)	Switch on instruction TLB miss
	(4)	Switch on L2 cache fetch miss
10	(5)	Switch on L2 cache store miss
	(6)	Switch on L2 instruction cache miss
	(7)	Switch on data TLB/segment lookaside buffer miss
	(8)	Switch on L2 cache miss and dormant thread not L2 cache miss
	(9)	Switch when thread switch time-out value reached
15	(10)	Switch when L2 cache data returned
	(11)	Switch on IO external accesses
	(12)	Switch on double-X store: miss on first of two*
	(13)	Switch on double-X store: miss on second of two*
	(14)	Switch on store multiple/string: miss on any access
20	(15)	Switch on load multiple/string: miss on any access
	(16)	Reserved
	(17)	Switch on double-X load: miss on first of two*
	(18)	Switch on double-X load: miss on second of two*
25	(19)	Switch on or 1,1,1 instruction if machine state register (problem state) bit, msr(pr)=1. Allows software priority change independent of msr(pr). If bit 19 is one, or 1,1,1 instruction sets low priority. If bit 19 is zero, priority is set to low only if msr(pr)=0 when the or 1,1,1 instruction is executed. See changing priority with software, to be discussed later.
	(20)	Reserved
30	(21)	Thread switch priority enable
	(22:29)	Reserved
	(30:31)	Forward progress count
	(32:63)	Reserved in 64 bit register implementation

35 * A double-X load/store refers to loading or storing an elementary halfword, a word, or a double word, that crosses a doubleword boundary. A double-X load/store in this context is not a load or store of multiple words or a string of words.

Thread Switch Time-out Register

40 As discussed above, coarse grained multithreaded processors rely on long latency events to trigger thread switching. Sometimes during execution, a processor in a multiprocessor environment or a background thread in a multithreaded architecture, has ownership of a resource that can have only a single owner and another processor or active thread requires access to the resource before it can make forward progress. Examples include updating a memory page

45

table or obtaining a task from a task dispatcher. The inability of the active thread to obtain ownership of the resource does not result in a thread switch event, nonetheless, the thread is spinning in a loop unable to do useful work. In this case, the background thread that holds the resource does not obtain access to the processor so that it can free up the resource because it never encountered a thread switch event and does not become the active thread.

Allocating processing cycles among the threads is another concern; if software code running on a thread seldom encounters long latency switch events compared to software code running on the other threads in the same processor, that thread will get more than it's fair share of processing cycles. Yet another excessive delay that may exceed the maximum acceptable time is the latency of an inactive thread waiting to service an external interrupt within a limited period of time or some other event external to the processor. Thus, it becomes preferable to force a thread switch to the dormant thread after some time if no useful processing is being accomplished to prevent the system from hanging.

The logic to force a thread switch after a period of time is a thread switch time-out register 430 (Figure 4), a decrementer, and a decrementer register to hold the decremented value. The thread switch time-out register 430 holds a thread switch time-out value. The thread switch time-out register 430 implementation used in this embodiment is shown in the following table:

Thread Switch Time-out Register Bits

(0:21)	Reserved
(22:31)	Thread switch time-out value

The embodiment of the invention described herein does not implement a separate thread switch time-out register 430 for each thread, although that could be done to provide more flexibility. Similarly, if there are multiple threads, each thread need not have the same thread switch time-out value.

Each time a thread switch occurs, the thread switch time-out value from the thread switch time-out register 430 is loaded by hardware into the decrement register. The decrement register is decremented once each cycle until the decrement register value equals zero, then a signal is sent to the thread switch controller 450 which forces a thread switch unless no other thread is ready to process instructions. For example, if all other threads in the system are waiting on a cache miss and are not ready to execute instructions, the thread switch controller 450 does not force a thread switch. If no other thread is ready to process instructions when the value in the decrement register reaches zero, the decremented value is frozen at zero until another thread is ready to process instructions, at which point a thread switch occurs and the decrement register is reloaded with a thread switch time-out value for that thread. Similarly, the decrement register could just as easily be named an increment register and when a thread is executing the register could increment up to some predetermined value when a thread switch would be forced.

The thread switch time-out register 430 can be written by a service processor as described above or by the processor itself with software code. The thread switch time-out value loaded into the thread switch time-out register 430 can be customized according to specific hardware configuration and/or specific software code to minimize wasted cycles resulting from unnecessary thread switching. Too high of a value in the thread switch time-out register 430 can result in reduced performance when the active thread is waiting for a resource held by another thread or if response latency for an external interrupt or some other event external to the processor is too long. Too high of a value can also prevent fairness if one thread experiences a high number of thread switch events and the other does not. A thread switch time-out value twice to several times longer than the most frequent longest latency event that causes a thread switch is recommended, e.g., access to main memory. Forcing a thread switch after waiting the number of cycles specified in the thread switch time-out

register 430 prevents system hangs due to shared resource contention, enforces fairness of processor cycle allocation between threads, and limits the maximum response latency to external interrupts and other events external to the processor.

5 Forward Progress Guarantee

That at least one instruction must be executed each time a thread switch occurs and a new thread becomes active is too restrictive in certain circumstances, such as when a single instruction generates multiple cache accesses and/or multiple
10 cache misses. For example, a fetch instruction may cause an L1 I-cache miss if the instruction requested is not in the cache; but when the instruction returns, required data may not be available in the L1 D-cache. Likewise, a miss in translation lookaside buffer can also result in a data
15 cache miss. So, if forward progress is strictly enforced, misses on subsequent accesses do not result in thread switches. A second problem is that some cache misses may require a large number of cycles to complete, during which time another thread may experience a cache miss at the same cache level which can
20 be completed in much less time. If, when returning to the first thread, the strict forward progress is enforced, the processor is unable to switch to the thread with the shorter cache miss. To remedy the problem of thrashing wherein each thread is locked in a repetitive cycle of switching threads
25 without any instructions executing, there exists a forward progress count register 420 (Figure 4) which allows up to a programmable maximum number of thread switches called the forward progress threshold value. After that maximum number of thread switches, an instruction must be completed before
30 switching can occur again. In this way, thrashing is prevented. Forward progress count register 420 may actually be bits 30:31 in the thread switch control register 410 or a software programmable forward progress threshold register for the processor. The forward progress count logic uses bits
35 15:17 of the thread state registers 442, 444 that indicate the state of the threads and are allocated for the number of thread

switches a thread has experienced without an instruction executing. Preferably, then these bits comprise the forward progress counter.

5 When a thread changes state invoking the thread switch algorithm, if at least one instruction has completed in the active thread, the forward-progress counter for the active thread is reset and the thread switch algorithm continues to compare thread states between the threads in the processor. If no instruction has completed, the forward-progress counter value in the thread state register of the active thread is compared to the forward progress threshold value. If the counter value is not equal to the threshold value, the thread switch algorithm continues to evaluate the thread states of the threads in the processor. Then if a thread switch occurs, the forward-progress counter is incremented. If, however, the counter value is equal to the threshold value, no thread switch will occur until an instruction can execute, i.e., until forward progress occurs. Note that if the threshold register has value zero, at least one instruction must complete within the active thread before switching to another thread. If each thread switch requires three processor cycles and if there are two threads and if the thread switch logic is programmed to stop trying to switch threads after five tries; then the maximum number of cycles that the processor will thrash is thirty cycles. One of skill in the art can appreciate that there a potential conflict exists between prohibiting a thread switch because no forward progress will be made on one hand and, on the other hand, forcing a thread switch because the time-out count has been exceeded. Such a conflict can easily be resolved according to architecture and software. Figure 6 is a flowchart of the forward progress count feature of thread switch logic 400 which prevents thrashing. At block 610, bits 15:17 in thread state register 442 pertaining to thread *T0* are reset to state *111*. Execution of this thread is attempted in block 620 and the state changes to *000*. If an instruction successfully executes on thread *T0*, the state of thread *T0* returns to *111* and remains so. If, however, thread

T0 cannot execute an instruction, a thread switch occurs to thread *T1*, or another background thread if more than two threads are permitted in the processor architecture. When a thread switch occurs away from *T1* or the other background thread and execution returns to thread *T0*, a second attempt to execute thread *T0* occurs and the state of thread *T0* becomes *001* as in block 630. Again, if thread *T0* encounters a thread switch event, control of the processor is switched away from thread *T0* to another thread. Similarly, whenever a thread switch occurs from the other thread, e.g., *T1*, back to thread *T0*, the state of *T0* changes to *010* on this third attempt to execute *T0* (block 640); to *011* on the fourth attempt to execute *T0* (block 650), and to state *100* on the fifth attempt to execute *T0* (block 660).

In this implementation, there are five attempts to switch to thread *T0*. After the fifth attempt or whenever the value of bits 15:17 in the thread state register (TSR) 442 is equal to the value of bits 30:31 plus one in the thread switch control register (TSC) 410, i.e., whenever $TSC(30:31) + 1 = TSR(15:17)$, no thread switch away from thread *T0* occurs. It will be appreciated that five attempts is an arbitrary number; the maximum number of allowable switches with unsuccessful execution, i.e., the forward progress threshold value, is programmable and it may be realized in certain architectures that five is too many switches, and in other architectures, five is too few. In any event, the relationship between the number of times that an attempt to switch to a thread with no instructions executing must be compared with a threshold value and once that threshold value has been reached, no thread switch occurs away from that thread and the processor waits until the latency associated with that thread is resolved. In the embodiment described herein, the state of the thread represented by bits 15:17 of the thread state register 442 is compared with bits 30:31 in the thread switch control register 410. Special handling for particular events that have extremely long latency, such as interaction with input/output devices, to prevent prematurely blocking thread switching with

forward progress logic improves processor performance. One way to handle these extremely long latency events is to block the incrementing of the forward progress counter or ignore the output signal of the comparison between the forward progress counter and the threshold value if data has not returned. Another way to handle extremely long latency events is to use a separate larger forward progress count for these particular events.

Thread Switch Manager

The thread state for all software threads dispatched to the processor is preferably maintained in the thread state registers 442 and 444 of Figure 4 as described. In a single processor one thread executes its instructions at a time and all other threads are dormant. Execution is switched from the active thread to a dormant thread when the active thread encounters a long-latency event as discussed above with respect to the forward progress register 420, the thread switch control register 410, or the thread switch time-out register 430. Independent of which thread is active, these hardware registers use conditions that do not dynamically change during the course of execution.

Flexibility to change thread switch conditions by a thread switch manager improves overall system performance. A software thread switch manager can alter the frequency of thread switching, increase execution cycles available for a critical task, and decrease the overall cycles lost because of thread switch latency. The thread switch manager can be programmed either at compile time or during execution by the operating system, e.g., a locking loop can change the frequency of thread switches; or an operating system task can be dispatched because a dormant thread in a lower priority state is waiting for an external interrupt or is otherwise ready. It may be advantageous to disallow or decrease the frequency of thread switches away from an active thread so that performance of the current instruction stream does not suffer the latencies resulting from switching into and out of it. Alternatively,

a thread can forgo some or all of its execution cycles by essentially lowering its priority, and as a result, decrease the frequency of switches into it or increase the frequency of switches out of the thread to enhance overall system performance. The thread switch manager may also unconditionally force or inhibit a thread switch, or influence which thread is next selected for execution.

A multiple-priority thread switching scheme assigns a priority value to each thread to qualify the conditions that cause a switch. It may also be desirable in some cases to have the hardware alter thread priority. For instance, a low-priority thread may be waiting on some event, which when it occurs, the hardware can raise the priority of the thread to influence the response time of the thread to the event. Relative priorities between threads or the priority of a certain thread will influence the handling of such an event. The priorities of the threads can be adjusted by the thread switch manager software through the use of one or more instructions, or by hardware in response to an event. The thread switch manager alters the actions performed by the hardware thread switch logic to effectively change the relative priority of the threads.

Three priorities are used with the embodiment described herein of two threads and provides sufficient distinction between threads to allow tuning of performance without adversely affecting system performance. With three priorities, two threads can have an equal status of medium priority. The choice of three priorities for two threads is not intended to be limiting. In some architectures a "normal" state may be that one thread always has a higher priority than the other threads. It is intended to be within the scope of the invention to cover more than two threads of execution having one or multiple priorities that can be set in hardware or programmed by software.

The three priorities of each thread are high, medium, and low. When the priority of thread *T0* is the same as thread *T1*, there is no effect on the thread switching logic. Both threads

have equal priority so neither is given an execution time advantage. When the priority of thread *T0* is greater than the priority of thread *T1*, thread switching from *T0* to *T1* is disabled for all L1 cache misses, i.e., data load, data store, and instruction fetch, because L1 cache misses are resolved much faster than other conditions such as L2 misses and translates. Thread *T0* is given a better chance of receiving more execution cycles than thread *T1* which allows thread *T0* to continue execution so long as it does not waste an excessive number of execution cycles. The processor, however, will still relinquish control to thread *T1* if thread *T0* experiences a relatively long execution latency. Thread switching from *T1* to *T0* is unaffected, except that a switch occurs when dormant thread *T0* is ready in which case thread *T0* preempts thread *T1*. This case would be expected to occur when thread *T0* switches away because of an L2 cache miss or translation request, and the condition is resolved in the background while thread *T0* is executing. The case of thread *T0* having a priority less than thread *T1* is analogous to the case above, with the thread designation reversed.

There are different possible approaches to implementing management of thread switching by changing thread priority. New instructions can be added to the processor architecture. Existing processor instructions having side effects that have the desired actions can also be used. Several factors influence the choice among the methods of allowing software control: (a) the ease of redefining architecture to include new instructions and the effect of architecture changes on existing processors; (b) the desirability of running identical software on different versions of processors; (c) the performance tradeoffs between using new, special purpose instructions versus reusing existing instructions and defining resultant side effects; (d) the desired level of control by the software, e.g., whether the effect can be caused by every execution of some existing instruction, such as a specific load or store, or whether more control is needed, by adding an instruction to the stream to specifically cause the effect.

The architecture described herein preferably takes advantage of an unused instruction whose values do not change the architected general purpose registers of the processor; this feature is critical for retrofitting multithreading capabilities into a processor architecture. Otherwise special instructions can be coded. The instruction is a "preferred nop" *or 0,0,0*; other instructions, however, can effectively act as a nop. By using different versions of the *or* instruction, *or 0,0,0* or *1,1,1* etc. to alter thread priority, the same instruction stream may execute on a processor without adverse effects such as illegal instruction interrupts. An extension uses the state of the machine state register to alter the meaning of these instructions. For example, it may be undesirable to allow a user to code some or all of these thread priority instructions and access the functions they provide. The special functions they provide may be defined to occur only in certain modes of execution, they will have no effect in other modes and will be executed normally, as a nop.

One possible implementation, using a dual-thread multithreaded processor, uses three instructions which become part of the executing software itself to change the priority of itself:

tsop 1 *or 1,1,1* - Switch to dormant thread
 tsop 2 *or 1,1,1* - Set active thread to LOW priority
 - Switch to dormant thread
 - NOTE: Only valid in privileged mode unless TSC[19]=1
 tsop 3 *or 2,2,2* - Set active thread to MEDIUM priority
 tsop 4 *or 3,3,3* - Set active thread to HIGH priority
 - NOTE: Only valid in privileged mode

Instructions tsop 1 and tsop 2 can be the same instruction as embodied herein as *or 1,1,1* but they can also be separate instructions. These instructions interact with bits 19 and 21 of the thread switch control register 410 and the problem/privilege bit of the machine state register as described herein. If bit 21 of the thread switch control register 410 has a value of one, the thread switch manager can set the priority of its thread to one of three priorities represented in the thread state register at bits 18:19. If bit

19 of the thread switch control register 410 has a value zero, then the instruction *tsop 2* thread switch and thread priority setting is controlled by the problem/privilege bit of the machine state register. On the other hand, if bit 19 of the thread switch control register 410 has a value one, or if the problem/privilege bit of the machine state register has a value zero and the instruction *or 1,1,1* is present in the code, the priority for the active thread is set to low and execution is immediately switched to the dormant or background thread if the dormant thread is enabled. The instruction *or 2,2,2* sets the priority of the active thread to medium regardless of the value of the problem/privilege bit of the machine state register. And the instruction *or 3,3,3*, when the problem/privilege bit of the machine state register bit has a value of zero, sets the priority of the active thread to high. If bit 21 of the thread switch control register 320 is zero, the priority for both threads is set to medium and the effect of the *or x,x,x* instructions on the priority is blocked. If an external interrupt request is active, and if the corresponding thread's priority is low, that thread's priority is set to medium.

The events altered by the thread priorities are: (1) switch on L1 D-cache miss to load data; (2) switch on L1 D-cache miss for storing data; (3) switch on L1 I-cache miss on an instruction fetch; and (4) switch if the dormant thread in ready state. In addition, external interrupt activation may alter the corresponding thread's priority. The following table shows the effect of priority on conditions that cause a thread switch. A simple *TSC* entry in columns three and four means to use the conditions set forth in the thread switch control (*TSC*) register 410 to initiate a thread switch. An entry of *TSC[0:2] treated as 0* means that bits 0:2 of the thread switch control register 410 are treated as if the value of those bits are zero for that thread and the other bits in the thread switch control register 410 are used as is for defining the conditions that cause thread switches. The phrase *when thread T0 ready* in column four means that a switch to thread *T0* occurs as soon as thread *T0* is no longer waiting on the miss event that caused

it to be switched out. The phrase *when thread T1 ready* in column 3 means that a switch to thread *T1* occurs as soon as thread *T1* is no longer waiting on the miss event that caused it to be switched out. If the miss event is a thread switch time-out, there is no guarantee that the lower priority thread completes an instruction before the higher priority thread switches back in.

<i>T0</i> Priority	<i>T1</i> Priority	<i>T0</i> Thread Switch Conditions	<i>T1</i> Thread Switch Conditions
High	High	TSC	TSC
High	Medium	TSC[0:2] treated as 0	TSC or if <i>T0</i> ready
High	Low	TSC[0:2] treated as 0	TSC or if <i>T0</i> ready
Medium	High	TSC or if <i>T1</i> ready	TSC[0:2] treated as 0
Medium	Medium	TSC	TSC
Medium	Low	TSC[0:2] treated as 0	TSC or if <i>T0</i> ready
Low	High	TSC or if <i>T1</i> ready	TSC[0:2] treated as 0
Low	Medium	TSC or if <i>T1</i> ready	TSC[0:2] treated as 0
Low	Low	TSC	TSC

It is recommended that a thread doing no productive work be given *low* priority to avoid a loss in performance even if every instruction in the idle loop causes a thread switch. Yet, it is still important to allow hardware to alter thread priority if an external interrupt is requested to a thread set at low priority. In this case the thread is raised to medium priority, to allow a quicker response to the interrupt. This allows a thread waiting on an external event to set itself at low priority, where it will stay until the event is signalled.

While the invention has been described in connection with what is presently considered the most practical and preferred embodiments, it is to be understood that the invention is not limited to the disclosed embodiments, but on the contrary, is intended to cover various modifications and equivalent arrangements included within the spirit and scope of the appended claims.

Claims

- 1 1. A computer processor comprising:
2 at least one multithreaded processor (100) to switch
3 execution between a plurality of threads of
4 instructions; and
5 at least one thread switch control register (410) having
6 a plurality of bits, each of said bits associated
7 uniquely with one of a plurality of thread switch
8 control events, the at least one thread switch
9 control register interconnected with the
10 multithreaded processor.
- 1 2. The processor of Claim 1 wherein if one of the bits is
2 enabled, the thread switch control event associated with that
3 bit causes the at least one multithreaded processor to switch
4 from one of a plurality of threads to another of said plurality
5 of threads.
- 1 3. The processor of Claim 1 or 2 wherein the thread switch
2 control register is programmable.
- 1 4. The processor of one of Claims 1 to 3 wherein at least one
2 instruction can disable at least one of the bits in the thread
3 switch control register.
- 1 5. The processor of one of Claims 1 to 4 comprising more than
2 one thread switch control register.
- 1 6. The processor of Claim 5 wherein the bit values of one
2 thread switch control register differs from the bit values of
3 another of said thread switch control registers.
- 1 7. The processor of one of Claims 1 to 6 wherein the
2 plurality of thread switch control events comprise a data miss
3 from at least one of the following: a L1-data cache, a L2
4 cache, a translation lookaside buffer.

1 8. The processor of one of Claims 1 to 7 wherein the
2 plurality of thread switch control events comprise an
3 instruction miss from at least one of the following: a L1-
4 instruction cache, a translation lookaside buffer.

1 9. The processor of one of Claims 1 to 8 wherein the
2 plurality of thread switch control events comprise an error in
3 address translation of data and/or an instruction.

1 10. The processor of one of Claims 1 to 9 wherein the
2 plurality of thread switch control events comprise access to
3 an I/O device external to said processor.

1 11. The processor of one of Claims 1 to 10 wherein the
2 plurality of thread switch control events comprise access to
3 another processor.

1 12. The processor of one of Claims 2 to 11 wherein the
2 plurality of thread switch control events comprise a forward
3 progress count of a number of times the one of a plurality of
4 threads has been switched from the at least one multithreaded
5 processor with no instruction of the one of a plurality of
6 threads executing.

1 13. The processor of one of Claims 1 to 12 wherein the
2 plurality of thread switch control events comprise a time-out
3 period.

1 14. A computer processing system comprising:
2 means for processing a plurality of threads of
3 instructions;
4 means for indicating when the processing means stalls
5 because one of the plurality of threads experiences
6 a processor latency event;
7 means for registering a plurality of thread switch
8 control events; and

9 means for determining if the processor latency event is
10 one of the plurality of thread switch control
11 events.

1 15. The computer processing system of Claim 14, further
2 comprising:

3 means for enabling the processing means to switch
4 processing to another of the plurality of threads if
5 the processor latency event is one of the plurality
6 of thread switch control events.

1 16. A method to determine contents of a thread switch control
2 register, comprising the steps of:

3 counting a first number of processor cycles in which a
4 multithreaded processor is stalled because of
5 processor latency event;

6 counting a second number of processor cycles required for
7 the multithreaded processor to switch processing of
8 a first thread of instructions to a second thread of
9 instructions;

10 assigning the processor latency event to be a thread
11 switch control event by setting an enable bit in the
12 thread switch control register if the first number
13 is greater than the second number.

1 17. The method of Claim 16, further comprising:

2 outputting a signal to switch threads when the
3 multithreaded processor experiences the thread
4 switch control event if the enable bit is enabled.

1 18. A method of computer processing comprising the steps of:

2 storing a state of a thread in a thread state register;
3 storing a plurality of thread switch control events in a
4 thread switch control register;
5 signaling the thread state register when the state of the
6 thread changes;

7 comparing the changed state of the thread with the
8 plurality of thread switch control events.

1 19. The method of Claim 18, further comprising:
2 signalling a multithreaded processor to switch execution
3 from the thread if the changed state results from a
4 thread switch control event.

1 20. A computer system, comprising:
2 a multithreaded processor (100) capable of switching
3 processing between at least two threads of
4 instructions when the multithreaded processor
5 experiences one of a plurality of processor latency
6 events;
7 at least one thread state register (440) operatively
8 connected to the multithreaded processor to store a
9 state of the threads of instructions wherein the
10 state of each thread of instructions changes when
11 the processor switches processing to each thread;
12 at least one thread switch control register (410)
13 operatively connected to the at least one thread
14 state register and to the multithreaded processor,
15 to store a plurality of thread switch control events
16 which thread switch control events are enabled by
17 setting a corresponding plurality of enable bits;
18 a plurality of internal connections connecting the
19 multithreaded processor to a plurality of memory
20 elements (120, 130, 140, 150) wherein access to any
21 of the plurality of memory elements by the
22 multithreaded processor causes a processor latency
23 event;
24 wherein when one of the threads executing in the
25 multithreaded processor is unable to continue execution
26 because of one of the processor latency events and when
27 that processor latency event is a thread switch control
28 event and when that corresponding enable bit is set, the

29 multithreaded processor switches execution to another of
30 the threads.

1 21. The computer system of Claim 20 further comprising at
2 least one external connection (155) connecting the
3 multithreaded processor to at least one external memory device
4 (170), at least one external communication device (174), an
5 external computer network (174), or at least one input/output
6 device (166) wherein access to any of the devices or the
7 network by the multithreaded processor causes one of the
8 plurality of processor latency events.

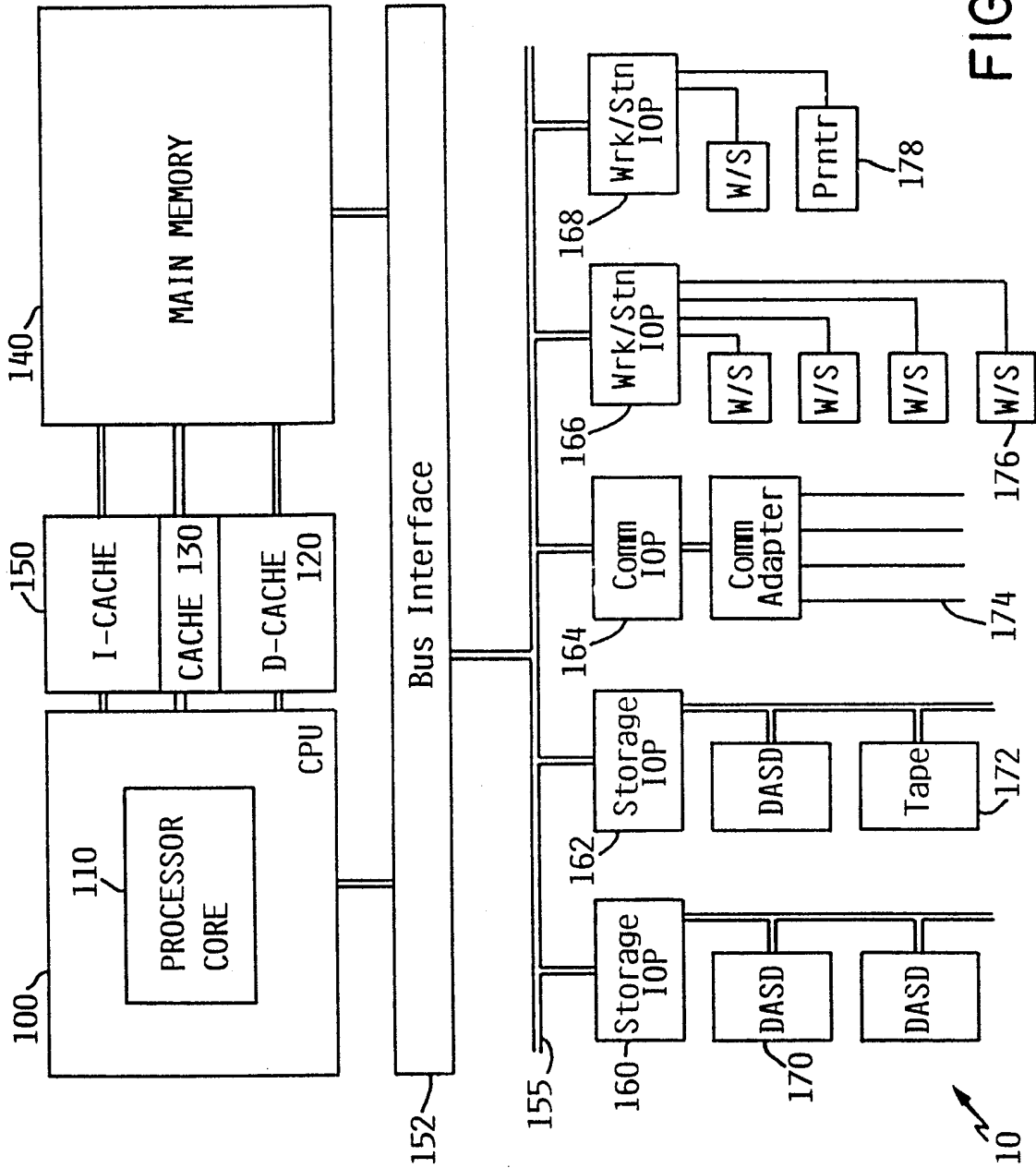
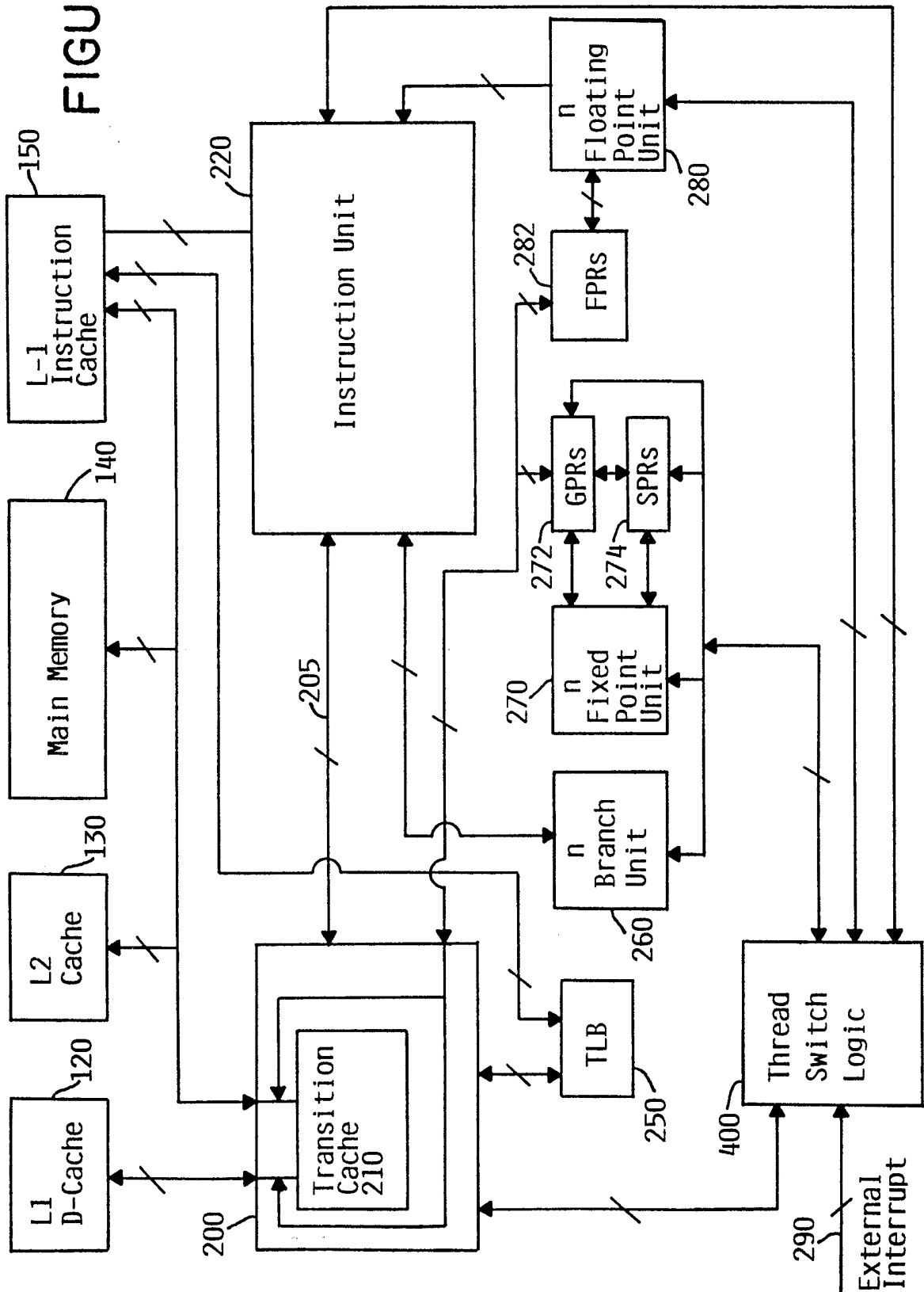

FIGURE 1

10

FIGURE 2



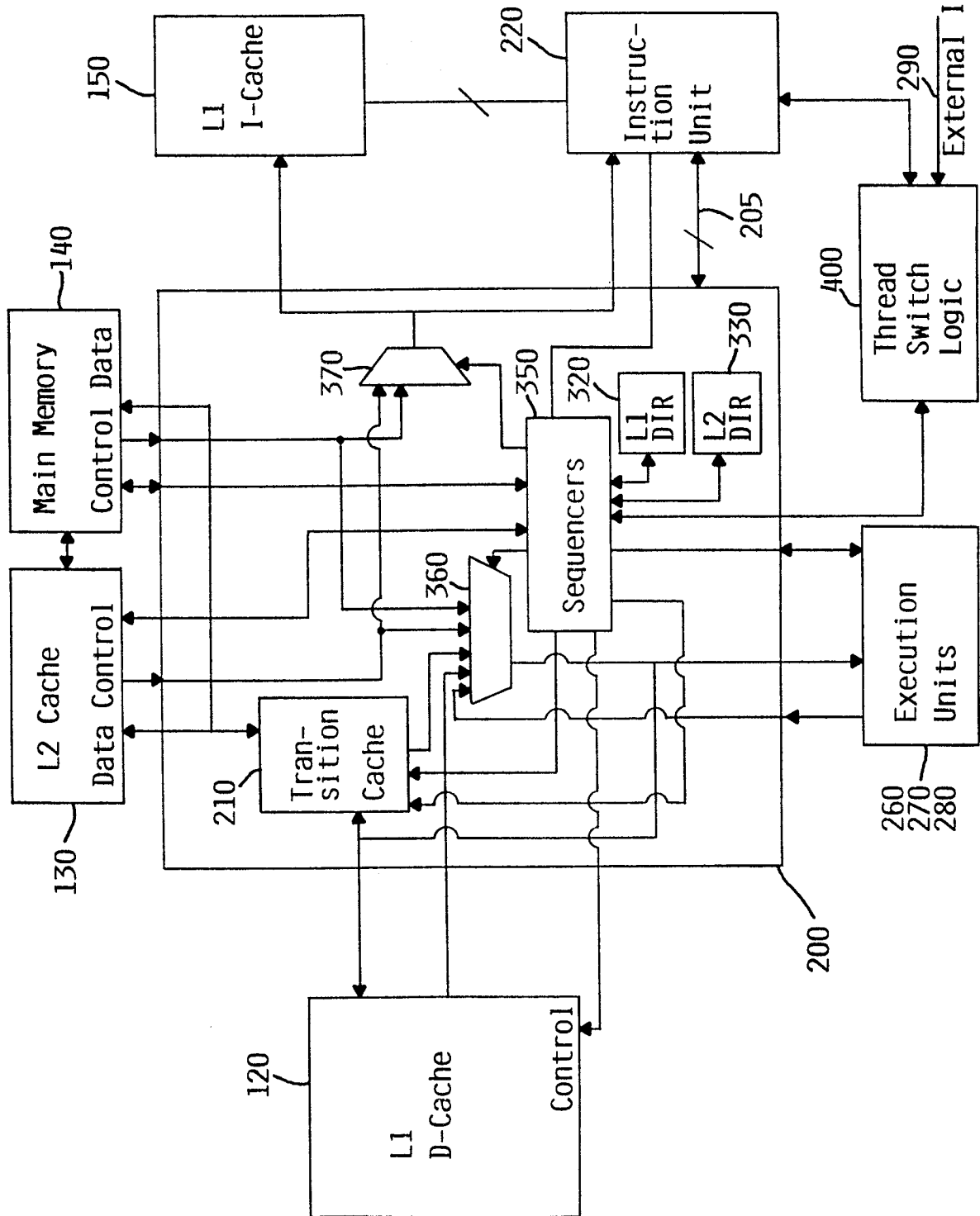

FIGURE 3

4/7

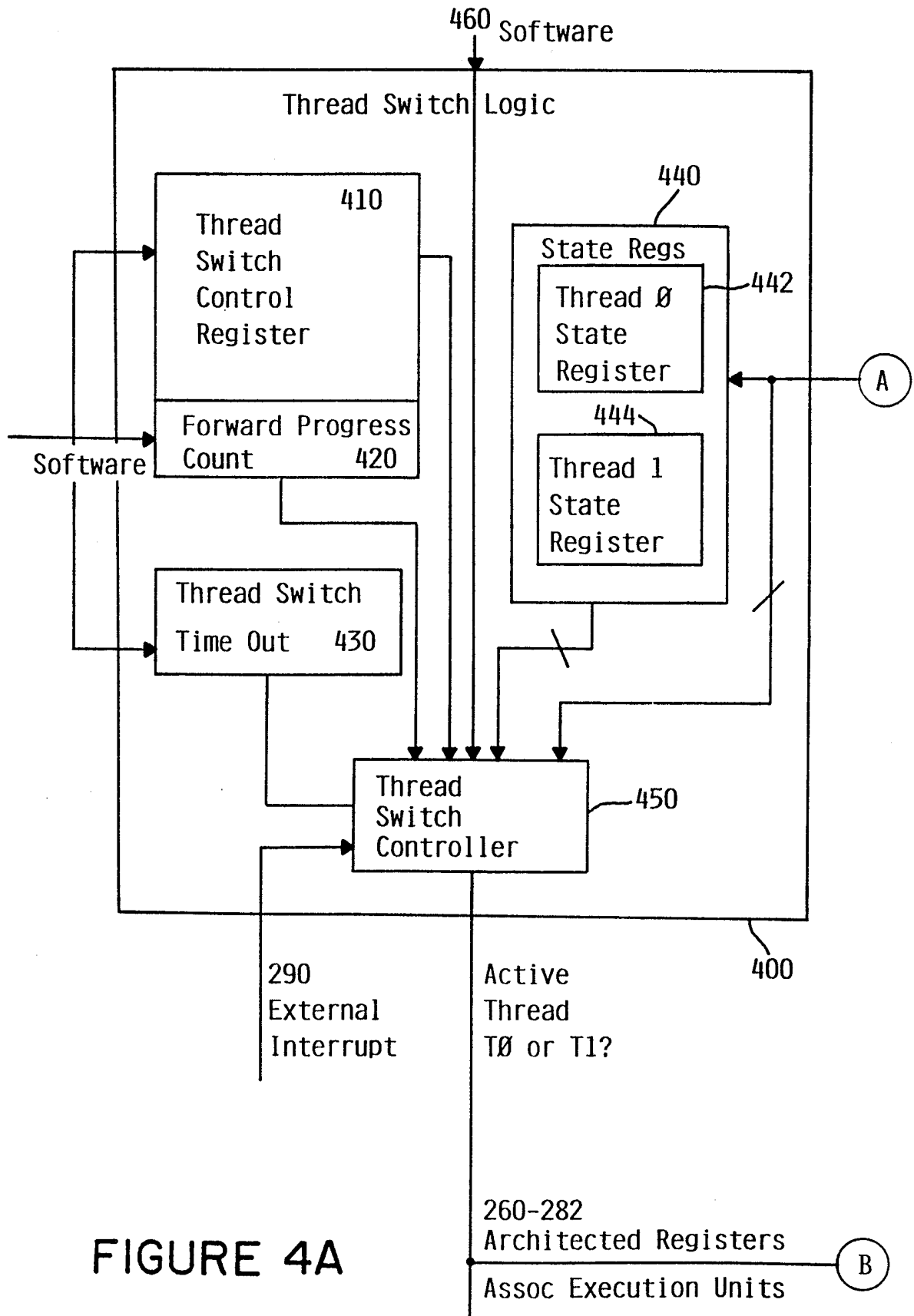

FIGURE 4A

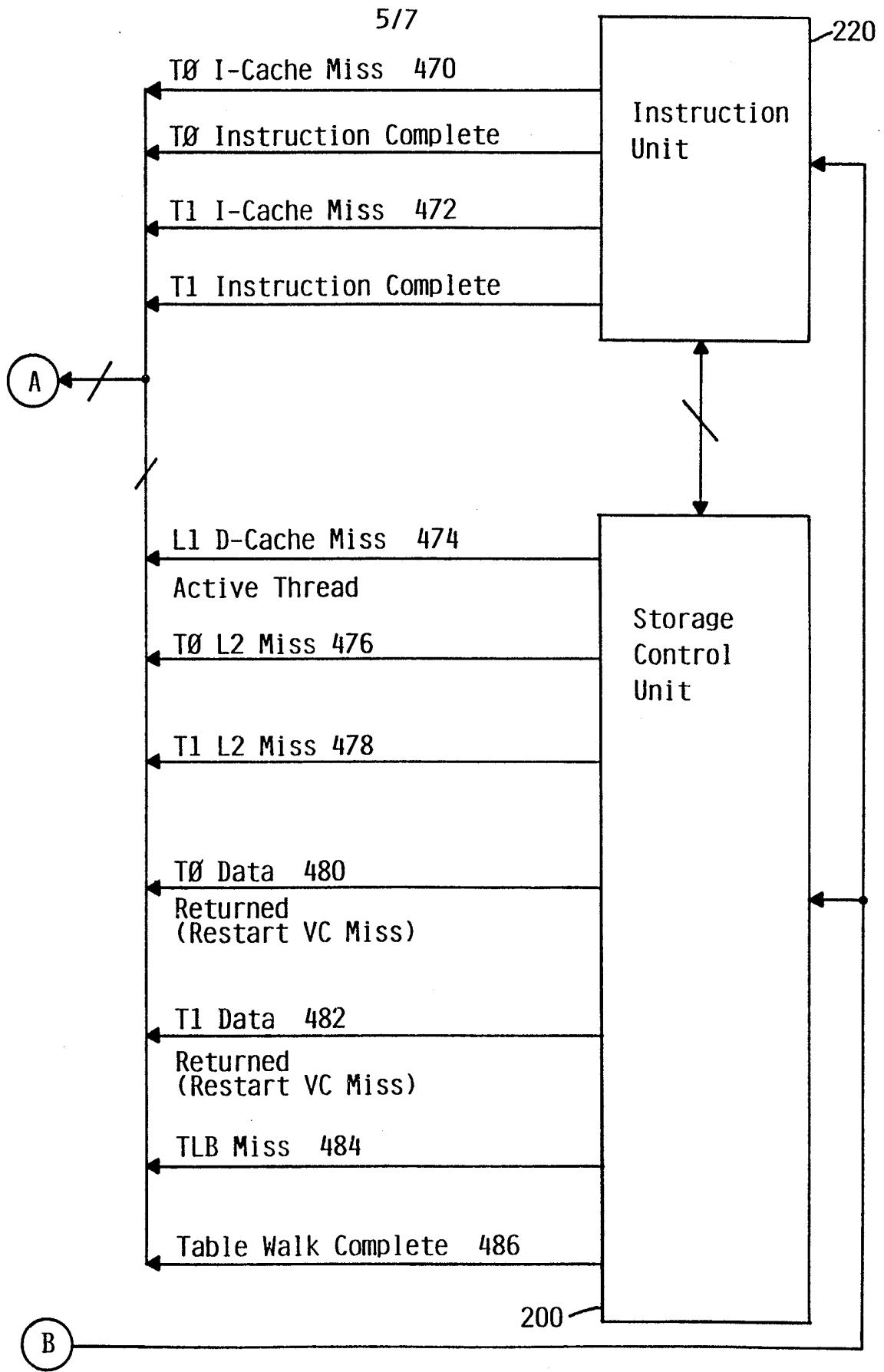
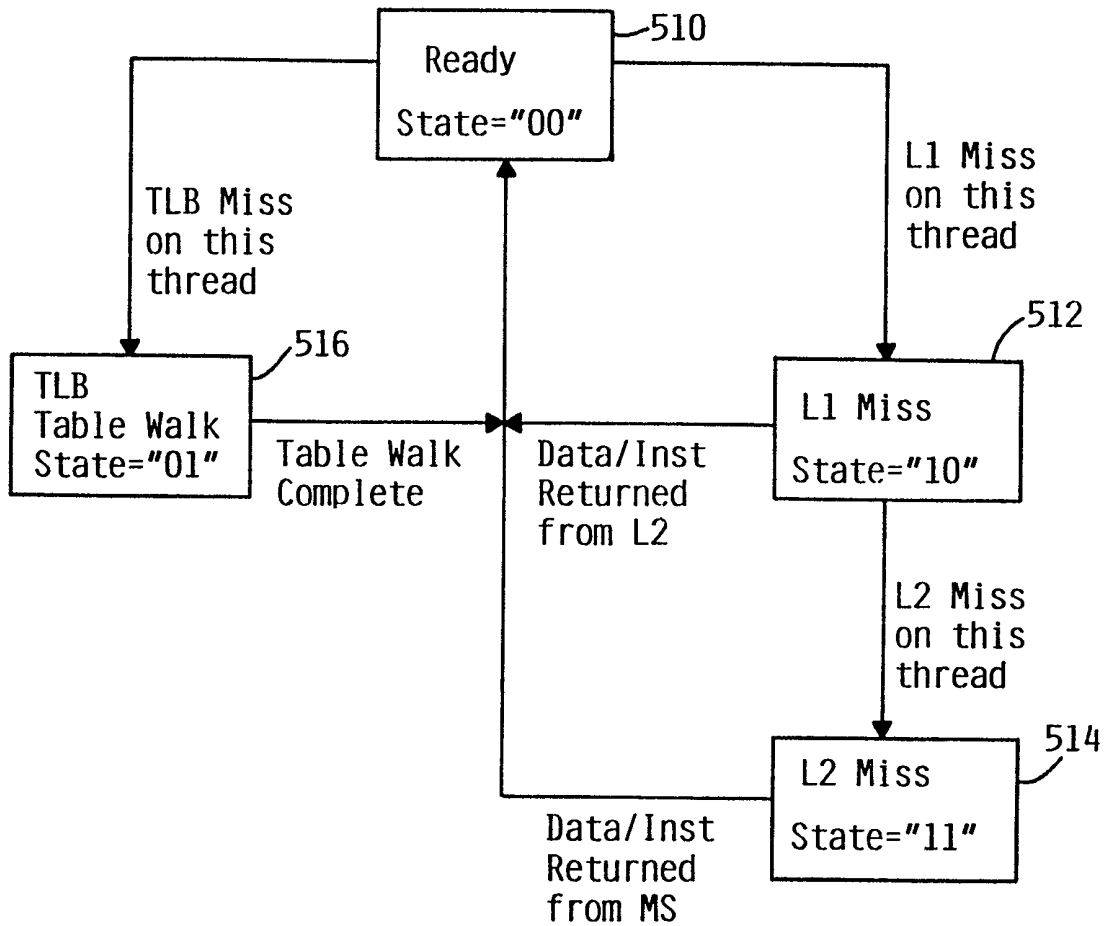

FIGURE 4B

Thread State Register. One Per Thread
Miss Type Bits (1 to 2)



State Hierarchy

- Highest = State "00" idle
- Next = State "10" L1 Miss
- Next = State "11" L2 Miss
- Lowest = State "01" Table Walk

FIGURE 5

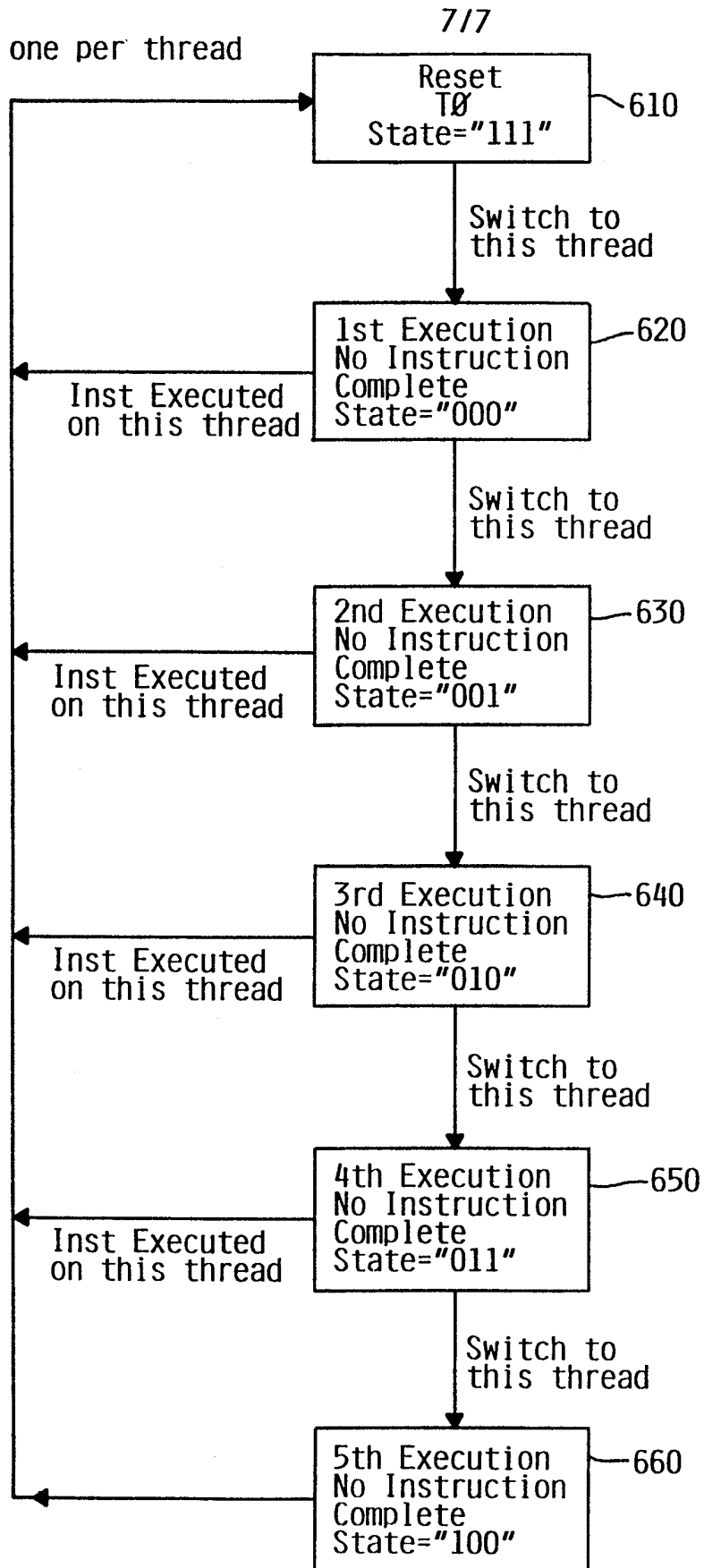

FIGURE 6

Progress Cnt Max = TSC (30 to 31) + 1
Block Thread Switch if TSR (15 to 17) for executing thread is equal to or greater than Progress Cnt Max

INTERNATIONAL SEARCH REPORT

Int. l. Application No

PCT/US 98/21716

A. CLASSIFICATION OF SUBJECT MATTER
 IPC 6 G06F9/38 G06F9/46

According to International Patent Classification (IPC) or to both national classification and IPC

B. FIELDS SEARCHED

Minimum documentation searched (classification system followed by classification symbols)

IPC 6 G06F

Documentation searched other than minimum documentation to the extent that such documents are included in the fields searched

Electronic data base consulted during the international search (name of data base and, where practical, search terms used)

C. DOCUMENTS CONSIDERED TO BE RELEVANT

Category *	Citation of document, with indication, where appropriate, of the relevant passages	Relevant to claim No.
A	EP 0 747 816 A (IBM) 11 December 1996 see abstract see column 2, line 32 - column 3, line 4 see column 4, line 4 - column 11, line 37; claims; figures ---	1, 14, 16, 18, 20
A	US 5 423 008 A (NAGHSHINEH KIANOOSH ET AL) 6 June 1995 see abstract see column 2, line 32 - column 3, line 3 ---	1, 14, 16, 18, 20
A	EP 0 617 361 A (DIGITAL EQUIPMENT CORP) 28 September 1994 see abstract see column 5, line 3 - column 7, last line see column 10, line 37 - column 17, line 35; claims; figures ---	1, 14, 16, 18, 20
	-/--	

Further documents are listed in the continuation of box C.

Patent family members are listed in annex.

* Special categories of cited documents :

- "A" document defining the general state of the art which is not considered to be of particular relevance
- "E" earlier document but published on or after the international filing date
- "L" document which may throw doubts on priority claim(s) or which is cited to establish the publication date of another citation or other special reason (as specified)
- "O" document referring to an oral disclosure, use, exhibition or other means
- "P" document published prior to the international filing date but later than the priority date claimed

- "T" later document published after the international filing date or priority date and not in conflict with the application but cited to understand the principle or theory underlying the invention
- "X" document of particular relevance; the claimed invention cannot be considered novel or cannot be considered to involve an inventive step when the document is taken alone
- "Y" document of particular relevance; the claimed invention cannot be considered to involve an inventive step when the document is combined with one or more other such documents, such combination being obvious to a person skilled in the art.
- "&" document member of the same patent family

Date of the actual completion of the international search

1 April 1999

Date of mailing of the international search report

12/04/1999

Name and mailing address of the ISA

European Patent Office, P.B. 5818 Patentlaan 2
 NL - 2280 HV Rijswijk
 Tel. (+31-70) 340-2040, Tx. 31 651 epo nl,
 Fax: (+31-70) 340-3016

Authorized officer

Wiltink, J

INTERNATIONAL SEARCH REPORT

International Application No

PCT/US 98/21716

C.(Continuation) DOCUMENTS CONSIDERED TO BE RELEVANT

Category °	Citation of document, with indication, where appropriate, of the relevant passages	Relevant to claim No.
A	GB 2 234 613 A (SUN MICROSYSTEMS INC) 6 February 1991 see abstract see page 2, line 25 - page 4, line 11; claims -----	1, 14, 16, 18, 20

INTERNATIONAL SEARCH REPORT

Information on patent family members

International Application No

PCT/US 98/21716

Patent document cited in search report	A	Publication date	Patent family member(s)	Publication date
EP 0747816	A	11-12-1996	JP 9006633 A	10-01-1997
US 5423008	A	06-06-1995	NONE	
EP 0617361	A	28-09-1994	NONE	
GB 2234613	A	06-02-1991	AU 638232 B	24-06-1993
			AU 5067290 A	07-02-1991
			HK 36894 A	29-04-1994
			JP 3071248 A	27-03-1991
			SG 124693 G	31-03-1994
			US 5361337 A	01-11-1994