

No. 607,209.

Patented July 12, 1898.

T. BECK.
FRUIT DRIER.

(Application filed Nov. 22, 1897.)

(No Model.)

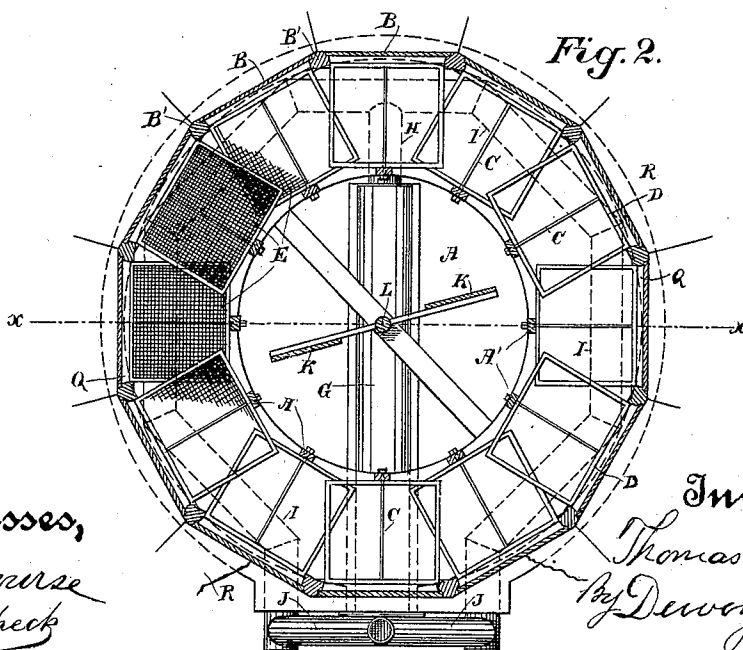
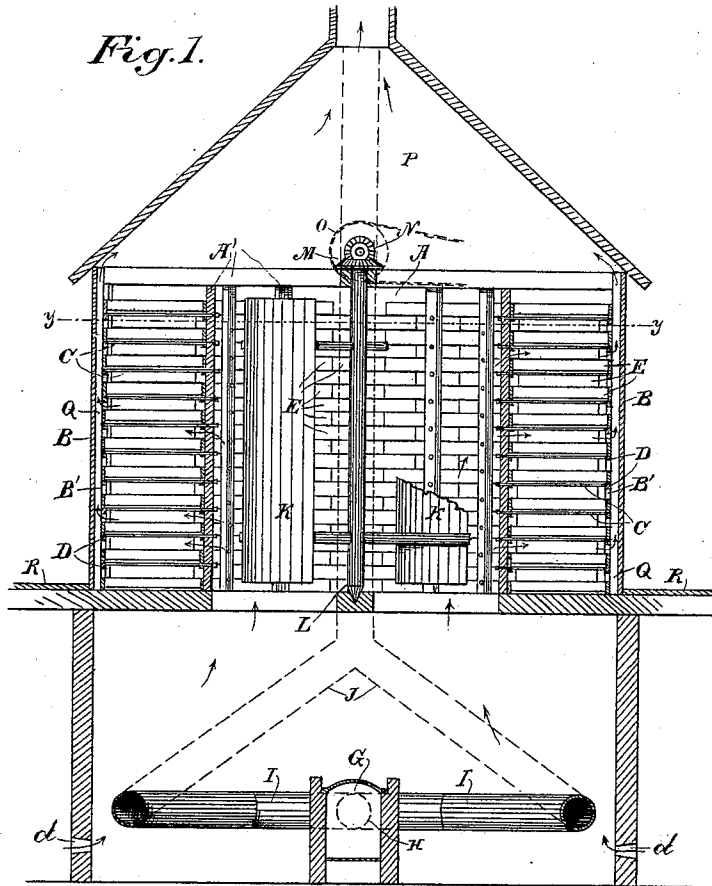

Witnesses,
G. A. Morse
J. F. Albrecht

Inventor,
Thomas Beck
by Dewey & Co.
attys.

UNITED STATES PATENT OFFICE.

THOMAS BECK, OF WATSONVILLE, CALIFORNIA.

FRUIT-DRIER.

SPECIFICATION forming part of Letters Patent No. 607,209, dated July 12, 1898.

Application filed November 22, 1897. Serial No. 659,394. (No model.)

To all whom it may concern:

Be it known that I, THOMAS BECK, a citizen of the United States, residing at Watsonville, county of Santa Cruz, State of California, have invented an Improvement in Fruit and Vegetable Driers; and I hereby declare the following to be a full, clear, and exact description of the same.

This invention relates to an apparatus for the more perfect desiccation or drying of fruit, vegetables, and other substances which it is desired to deprive of moisture.

It consists, essentially, of a polygonal chamber having peripheral doors opening through each of the faces of the polygon, fruit-trays, and supports upon which said trays are supported so as to leave a space between the front edges of the trays and the inner faces of the doors, with jambs by which this peripheral space is divided into a number of vertical flues corresponding with the number of doors and series of superposed fruit-trays, a centrally-disposed rotary fan by which air is forced outwardly over the trays, thence discharged through the vertical flues, and a heating-furnace in the lower part of the apparatus by which the air is heated, so as to rise into the central chamber and be thence distributed and discharged over the fruit-trays.

It also consists in details of construction which will be more fully explained by reference to the accompanying drawings, in which—

Figure 1 is a vertical section through my apparatus, showing the interior construction on line $x x$ of Fig. 2. Fig. 2 is a horizontal section through $y y$ of Fig. 1.

In the drying of fruit, vegetables, and other material by means of mechanical driers great difficulty has been found in disposing the trays, cars, or other receptacles for the fruit in such a manner that the air which passes over the fruit to be dried can be at once removed as soon as it becomes laden with moisture instead of being continued in contact with the subsequent trays or cars in such a manner that it finally becomes so loaded with

moisture as to again deposit it and thus delay or prevent the proper drying of all the fruit. My invention is designed to overcome this difficulty, and it is effected in the following manner:

A is a chamber of any suitable or desired size, preferably made polygonal in form, having as many faces as there are doors B. These doors are either hinged, slidable, or in other ways conveniently disposed so that they may be readily opened and closed, and when closed the exterior periphery of the chamber will present as many polygonal faces as there are doors. Vertical jambs B' between the doors separate the space just inside the doors into as many vertical flues as there are doors. This portion of the structure is built upon a lower portion which constitutes the heating-chamber and which contains the furnace, as will be hereinafter described.

From the center of each of the polygonal sides a supporting rod or bar C extends radially toward the center, where its inner end is supported by a post or other support A', the outer end being connected with a tray-rest D, which is parallel with the surface of the door B and is fixed at a sufficient distance inside of the door to leave a space which when the door is closed will, with the jambs, form a vertical flue extending from the bottom to the top of the chamber. These rods and the tray-rest together form a sufficient support for the fruit-trays, the inner ends of which are centrally supported on the rod, while the outer ends rest upon the bar D, and as the whole length of the front of the tray is thus supported it will be maintained sufficiently steady in place. Each adjacent tray-rest and supporting-rod D and C is alternately depressed and raised, so that when rectangular trays E, such as are usually made for fruit, are in position one tray is slightly above the next adjacent ones, the trays thus alternating up and down all the way around the circumference of the chamber. This allows the ordinary rectangular trays to be used, and as they overlap each other a third more drying-space is obtained. The whole cham-

ber is thus made up to any desired height by superposed series of tray-rests and rods, so that any desired number of trays can be placed upon their supports, one above the other, opposite to each of the doors B, until the chamber is filled from bottom to top, when the doors are closed. There will then be an open channel or flue Q extending vertically from the bottom to the top between the inner surfaces of the doors and the outer edges or fronts of the trays. This space may be made of any suitable or desired size, and the object is to allow the air which has been forced outward over the trays to pass upwardly through these flues without again coming in contact with any of the contents of the trays.

The vertical door-jambes B' fill the space at the edges of each of the doors, so that when the doors are closed there is an independent flue for each vertical series of trays standing opposite each of the doors.

In order to provide a volume of heated air sufficient for drying purposes, I have shown a furnace G, which is situated in the lower part of the structure, this latter being built of brick, concrete, or any suitable or desired material. The furnace is provided with a grate in the usual manner for the combustion of any available or desired fuel and is here shown as extending diametrically across the lower part of the chamber. From the rear portion of the furnace a pipe or flue H communicates with the heating-drum I, which receives the heated products of combustion. This drum is made in sections, so as to approximately make a polygonal form extending around the inner periphery of the lower part of the chamber, and at the front, upon each side of the furnace, it is connected by converging flues J with a suitable escape-flue or chimney, the construction being such that the heated products of combustion passing rearwardly through the furnace and pipe H and being delivered into the heating-drum I will pass around in each direction to the discharge-pipes J and thence to the chimney. The air in the lower portion being thus heated rises into the central portion of the chamber A. Within this chamber is a rotary fan K, consisting of vanes or floats of any desired or suitable description and form, and this fan standing vertically in the chamber has a driving-shaft L, stepped at the bottom and receiving motion through beveled gear and pinion, as shown at M, this again being driven through the shaft N and belt-pulley or other means for communicating power, as shown at O.

The upper ends of the flues formed between the doors B and the outer fronts of the trays open into a conical hood P, which forms the dome that completes the structure, and this hood converges to a discharge pipe or flue at the top, through which all the heated products eventually escape.

The operation of the apparatus will then be as follows: As soon as the trays of fruit have been placed upon their supports and the structure thus filled with the trays surrounding the central fan, the fire having been made in the furnace, the fan is set in operation, and the heated air which arises from the furnace into the upper part is thus forced outwardly in every direction over the surface of the fruit in all of the surrounding trays. This air thus passing over the surface of the trays will remove a certain amount of moisture from the material to be dried and is immediately discharged into the surrounding escape-flues, whence it is carried away and is not again brought into contact with the fruit, thus avoiding a serious difficulty which arises from the gradually-cooling air being continued in contact with the fruit and eventually again depositing its moisture farther on by reason of its cooling.

By constructing the tray-supports as here shown, so that alternate trays are situated above and below the next adjacent ones, I am enabled to employ ordinary rectangular trays, which can be placed upon their supports, and they will overlap each other at the inner angles, as shown in the plan view. This makes it unnecessary to construct the trays converging to correspond with the decreasing space from the outside to the inside of the space occupied by them and at the same time provides for a much larger area for drying purposes.

In the wall of the heating-chamber are located a series of holes *d* to supply the chamber with fresh air.

R represents a working floor to afford access to the doors.

Having thus described my invention, what I claim as new, and desire to secure by Letters Patent, is—

1. A fruit-drying apparatus consisting of a structure having a heating-furnace and flues in the lower part, a central chamber superposed upon the heating portion having a rotary fan or air-forcing apparatus therein, doors forming polygonal faces around the exterior of the structure, tray-supports interior to said doors extending radially toward the central chamber, vertical jambs which with the doors form three sides of vertically-disposed flues, exterior to the tray-fronts whereby air forced outwardly over and through the fruit is independently discharged through each of the vertical flues.

2. In a drier, a heating-chamber containing a furnace and heating-flues, a superposed chamber having a vertical central shaft, a rotary fan and mechanism by which it is driven, tray-supports exterior to said chamber, said supports being disposed so that alternate trays are situated above and below the adjacent ones so that they overlap each other, vertical jambs or door-posts forming

the angles of a polygon and doors closable
between each pair of jambs so as to form an
exterior polygonal face when closed and al-
lowing the fruit-trays to be introduced and re-
5 moved when opened, vertical flues formed be-
tween the jambs and the doors and the front
faces of the trays whereby heated air forced
outwardly by the rotating fan is delivered

vertically upward to an escape-flue after hav-
ing passed over the fruit.

In witness whereof I have hereunto set my
hand.

THOMAS BECK.

Witnesses:

S. H. NOURSE,
JESSIE C. BRODIE.

10