



US007158945B1

(12) **United States Patent**
Wolcott et al.

(10) **Patent No.:** **US 7,158,945 B1**
(45) **Date of Patent:** **Jan. 2, 2007**

(54) **SYSTEM AND METHOD FOR PROVIDING IMAGE PRODUCTS AND/OR SERVICES**

(75) Inventors: **Dana W. Wolcott**, Honeoye Falls, NY (US); **Dale F. McIntyre**, Rochester, NY (US); **Kenneth A. Parulski**, Rochester, NY (US)

(73) Assignee: **Eastman Kodak Company**, Rochester, NY (US)

(*) Notice: Subject to any disclaimer, the term of this patent is extended or adjusted under 35 U.S.C. 154(b) by 0 days.

(21) Appl. No.: **09/574,985**

(22) Filed: **May 19, 2000**

Related U.S. Application Data

(63) Continuation-in-part of application No. 09/534,471, filed on Mar. 24, 2000.

(51) **Int. Cl.**
G06Q 30/00 (2006.01)
G06F 17/30 (2006.01)

(52) **U.S. Cl.** **705/26; 705/27**
(58) **Field of Classification Search** **705/26, 705/27, 4, 40; 396/6; 358/1.15**
See application file for complete search history.

(56) **References Cited**

U.S. PATENT DOCUMENTS

5,633,678 A 5/1997 Parulski et al.
5,974,401 A * 10/1999 Enomoto et al. 355/40
6,167,469 A * 12/2000 Safai et al. 710/62
6,369,908 B1 * 4/2002 Frey et al. 358/1.15

FOREIGN PATENT DOCUMENTS

JP 08037637 A * 2/1996

OTHER PUBLICATIONS

"Texas Instruments leads industry in targeting cost of ownership as market focus to low-end minicomputer business" PR Newswire (Jul. 2, 1985).*

"Toro Selects SIGNAL Internet Technologies for Web-Based Warranty Registration And Claims Processing" PR Newswire (Sep. 15, 1998).*

"Photo-processing rivals multiply; so do promotions" Discount Store News, vol. 24 (Apr. 1, 1985) p. 93.*

"Agfa Rolls First APS Disposable" Brandweek (Nov. 11, 1996) p. 16.*

(Continued)

Primary Examiner—Matthew S Gart

(74) *Attorney, Agent, or Firm*—Thomas J. Strouse

(57) **ABSTRACT**

A system and method for obtaining photographic products and/or services comprises bundling image capture and printing technologies into products and/or services that are paid for by a consumer with monthly or yearly subscription fees. The system and method involves selecting a camera and selecting a photographic products/service plan which designates photographic products and/or services which are to be associated with the selected camera. The system and method gives the consumer the option of selecting a specific camera from a menu of cameras, and a specific photographic product/service plan which is to be associated with the selected camera from a product/service menu. As a further option, the consumer can customize his/her product/service plan in accordance with his/her preference. The plan can provide for products and/or services for images captured and/or film exposed by the camera for a predetermined amount of time at a predetermined fee. At the end of the plan, the consumer could have the option of returning the camera, exchanging the camera for a different camera, or keeping the camera at no cost or for a reduced price. The photographic products and/or services provided by the plan could be products and/or services such as film developing, printing, image products, scanning, photo CDs, image storage, etc.

35 Claims, 12 Drawing Sheets

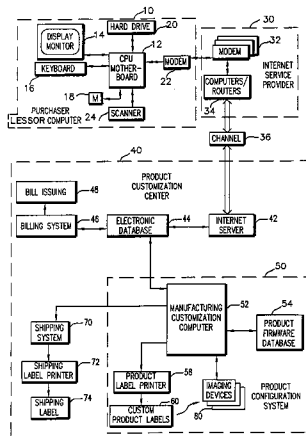

OTHER PUBLICATIONS

"Ofoto.com Launches Innovative Photo Finishing Service" PR Newswire (Dec. 13, 1999).*

"Iomega Announces Digital Imaging Strategy, Offers Storage Solutions to Create, Enhance, Edit and Share Images" Business Wire (Nov. 16, 1999).*

<http://web.archive.org/web/19991013054322/http://clubphoto.com/>.*

<http://web.archive.org/web/19991003202850/www.clubphoto.com/memberservices/join.php>.*

Frink, S. "Ocean Divers; a full service dive resort on the shores of Pennekamp Park" Skin Diver (Aug. 1985) vol. 34, p. 102.*

Creative Gallery: 'Olympus Camera Craze' Promo (Sep. 1994).*

"Film Processors Deliver Snapshots Electronically To Your Computer" Orange County Register (Mar. 4, 1997).*

"New sites offer prints from digital cameras" Photo Marketing Newslines (Dec. 15, 1999).*

"Camera buyers get free World Wide Web posting" Nikkei Weekly, (Feb. 14, 2000) vol. 38 p. 12.*

Ricoh to Bundle Club Photo Internet-based Photo Sharing Software with New 2-Megapixel Digital Camera Business Wire Jun. 8, 1999.*

Cameraworld (<http://web.archive.org/web/19970414000034/http://www.cameraworld.com/index.html>).*

* cited by examiner

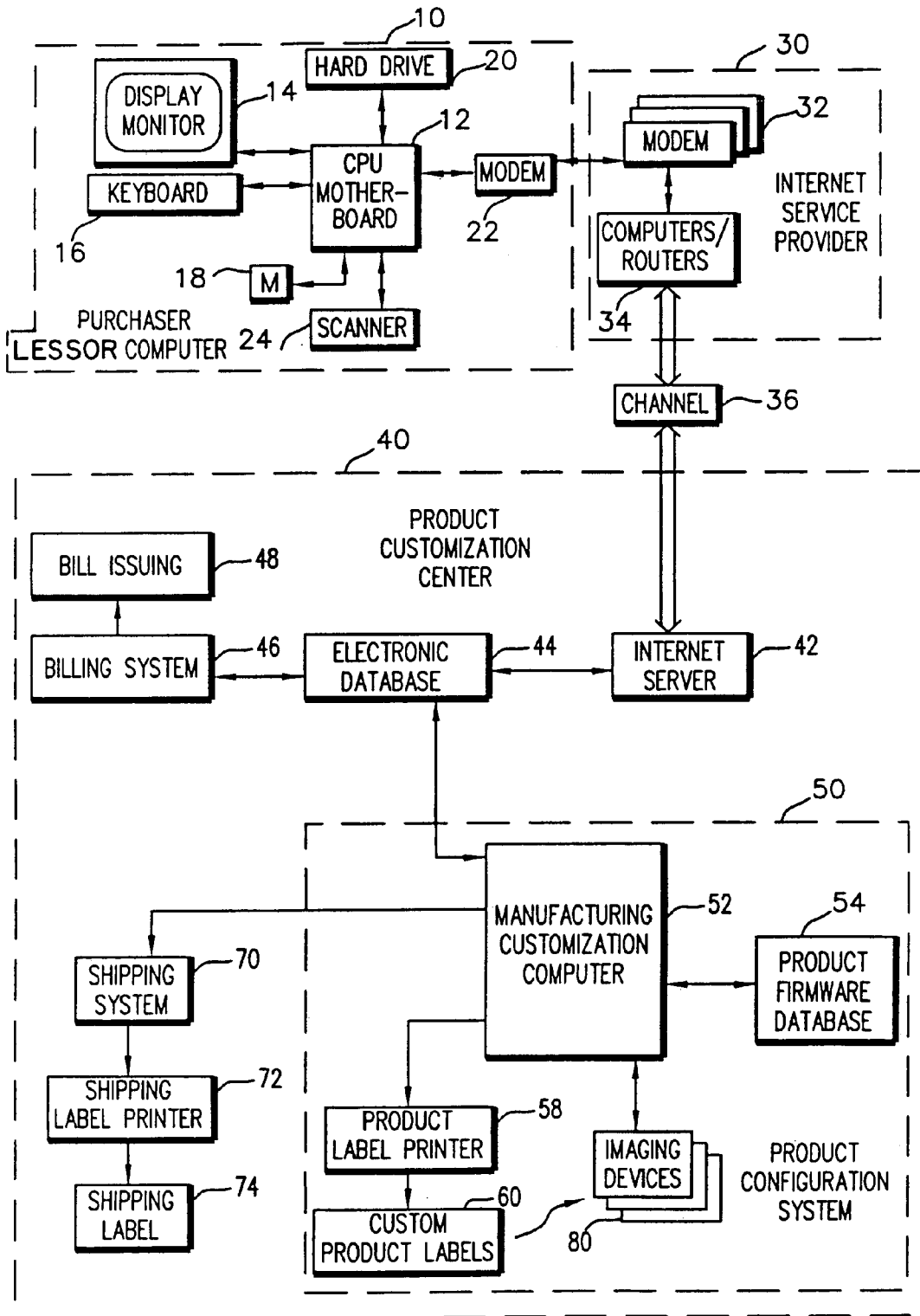

FIG. 1

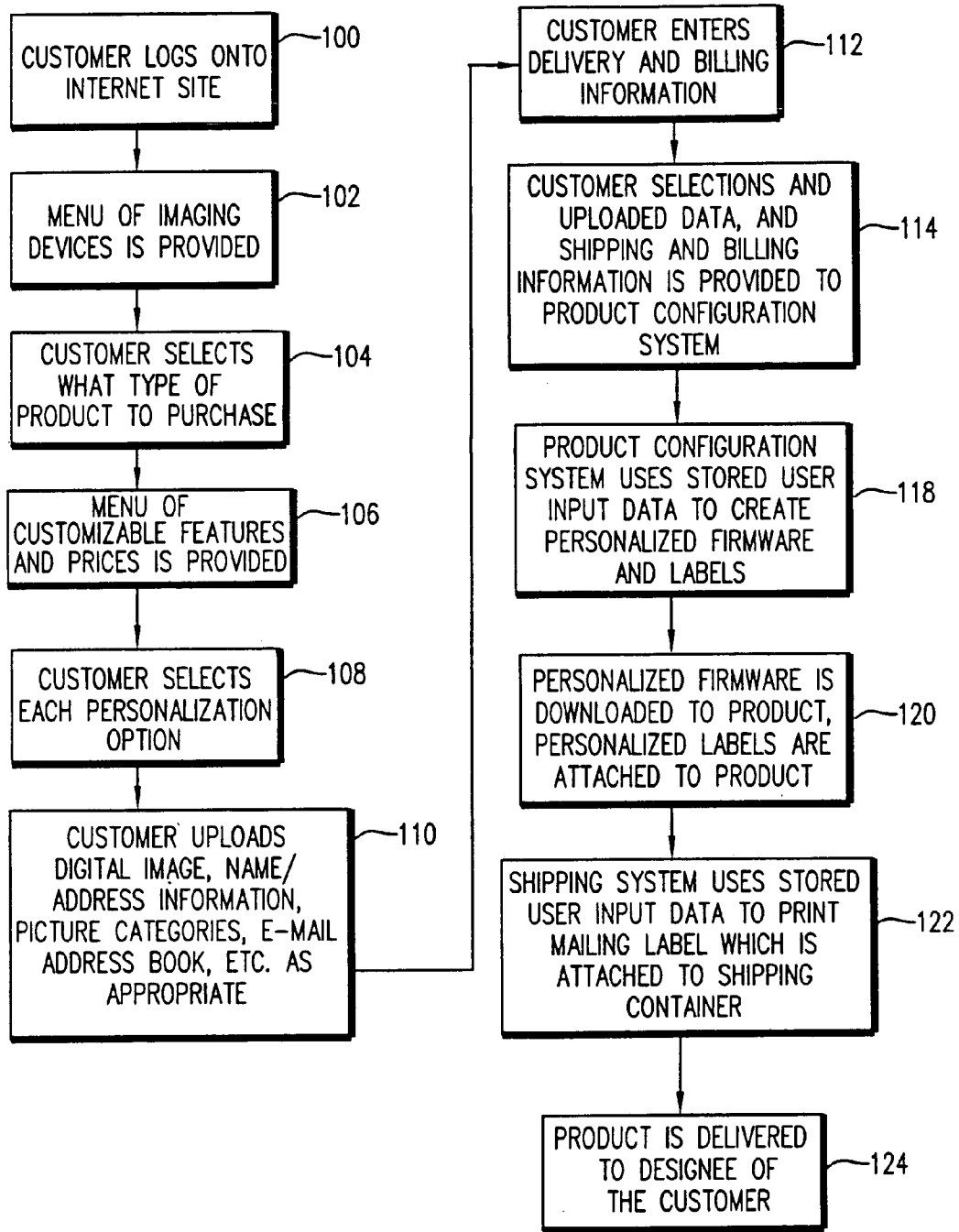

FIG. 2

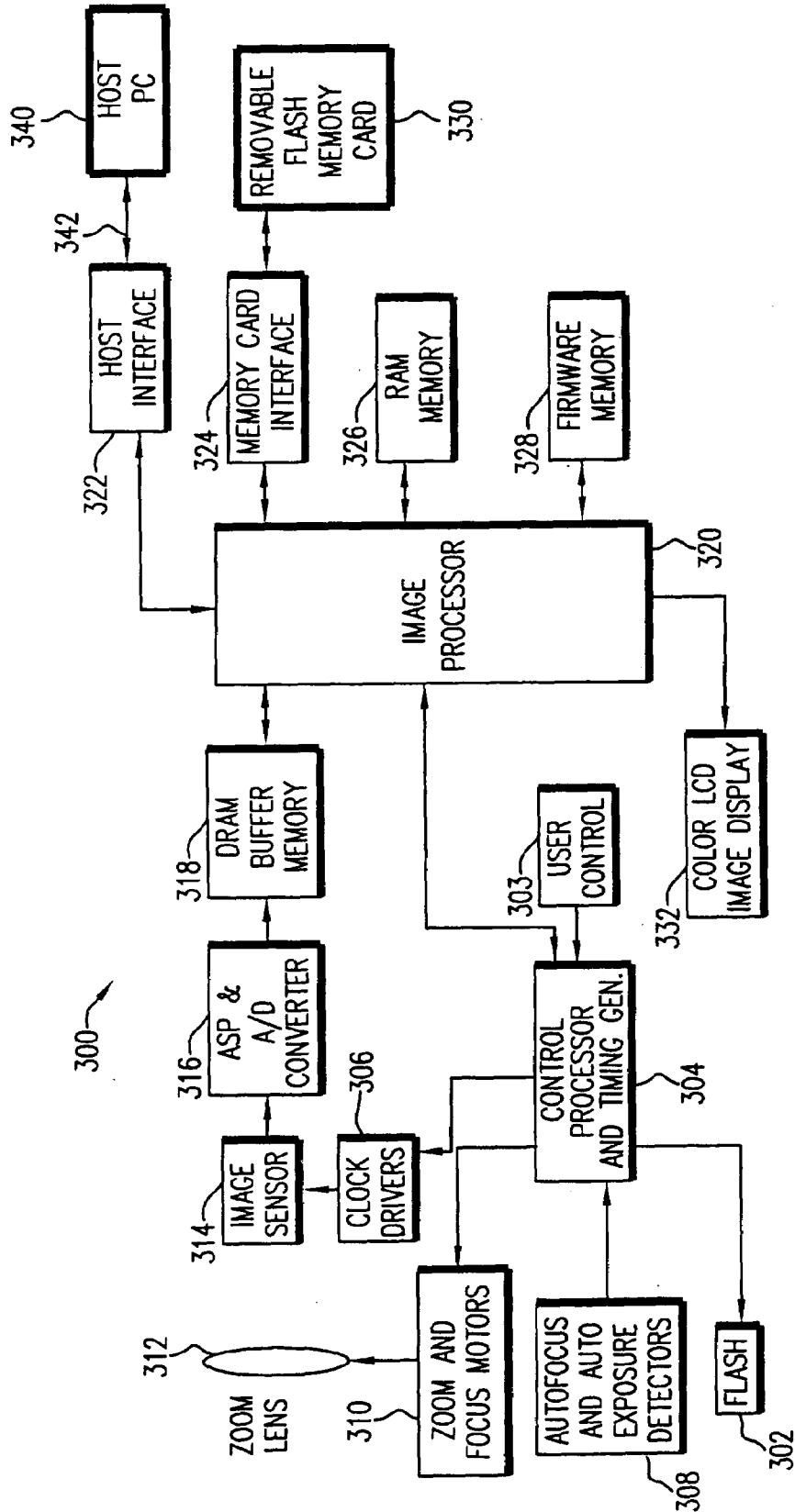

FIG. 3

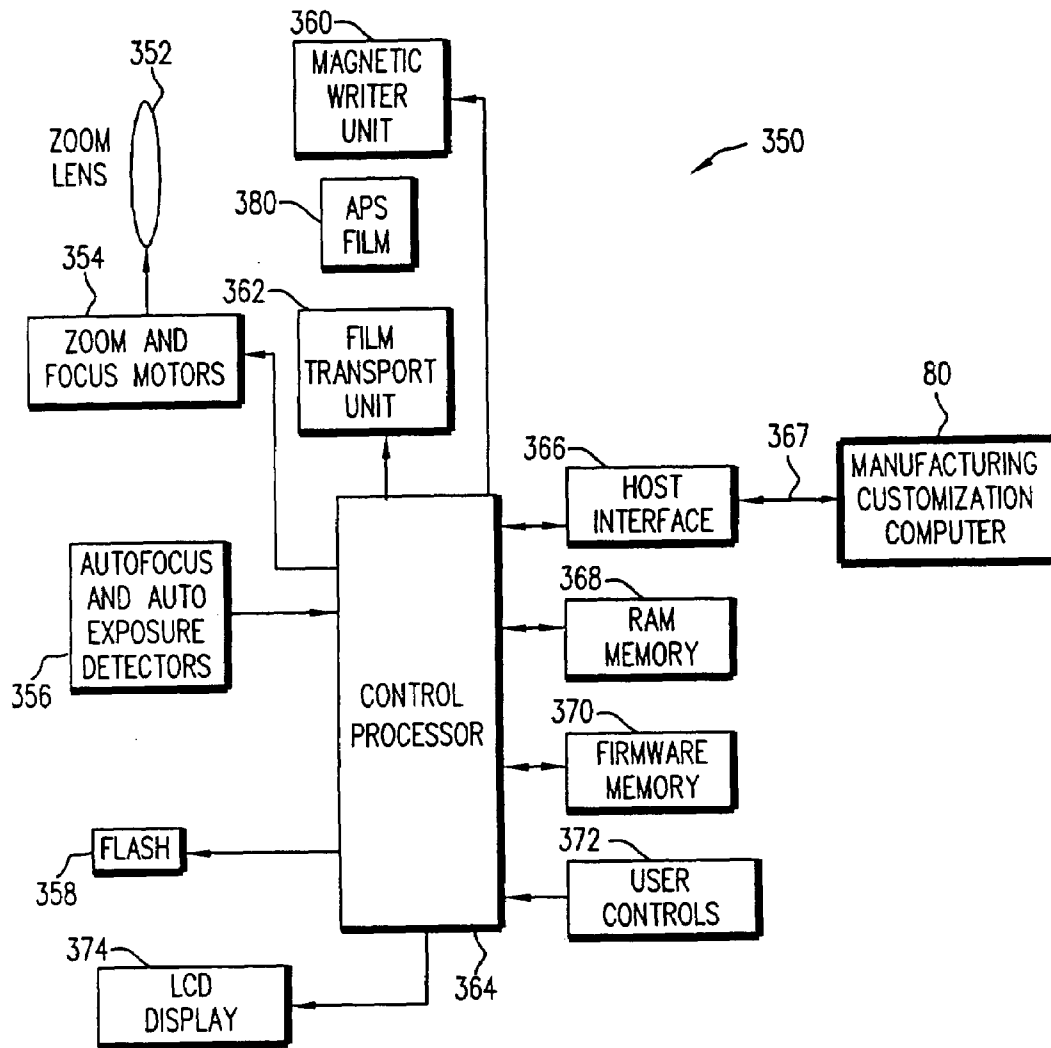

FIG. 4

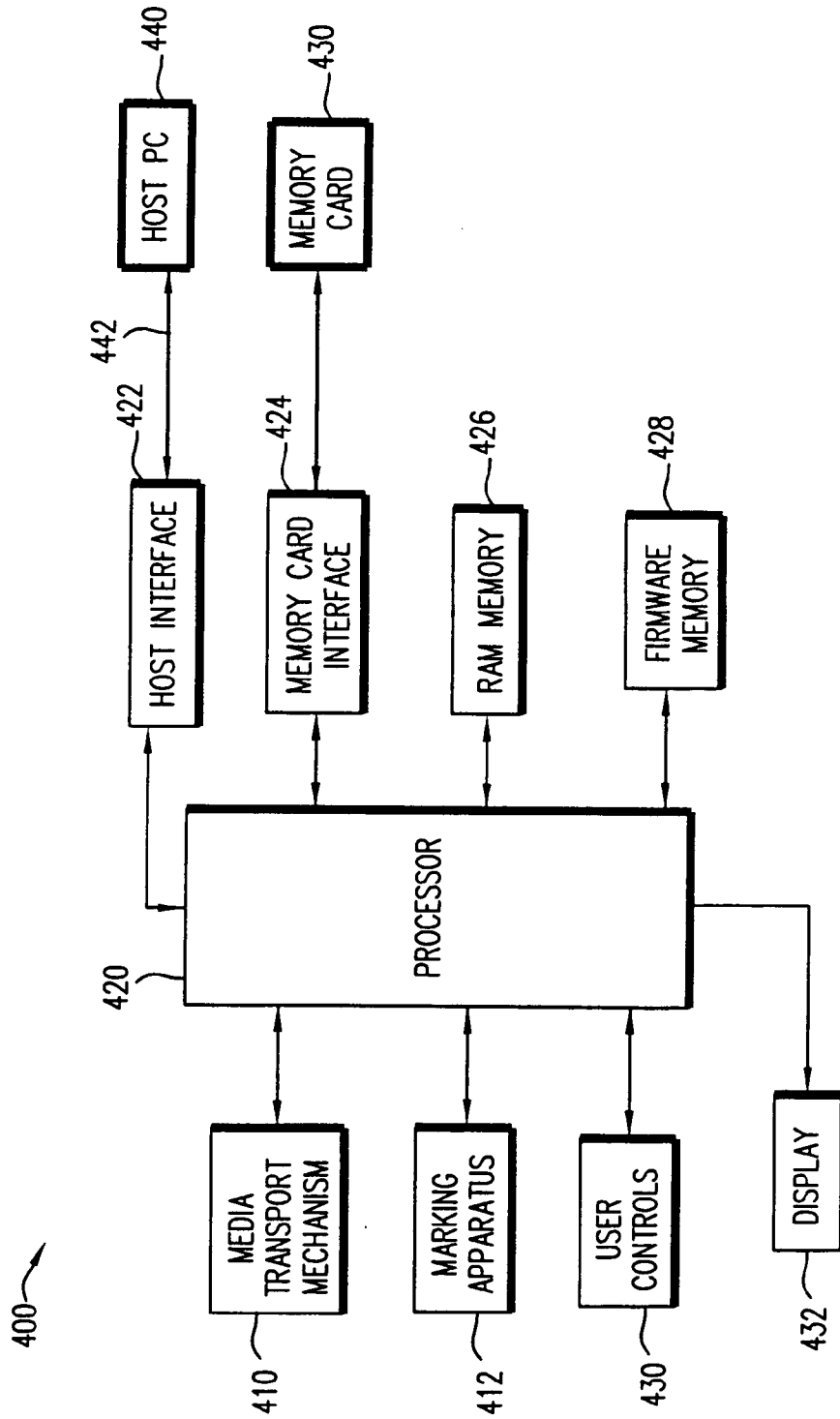

FIG. 5

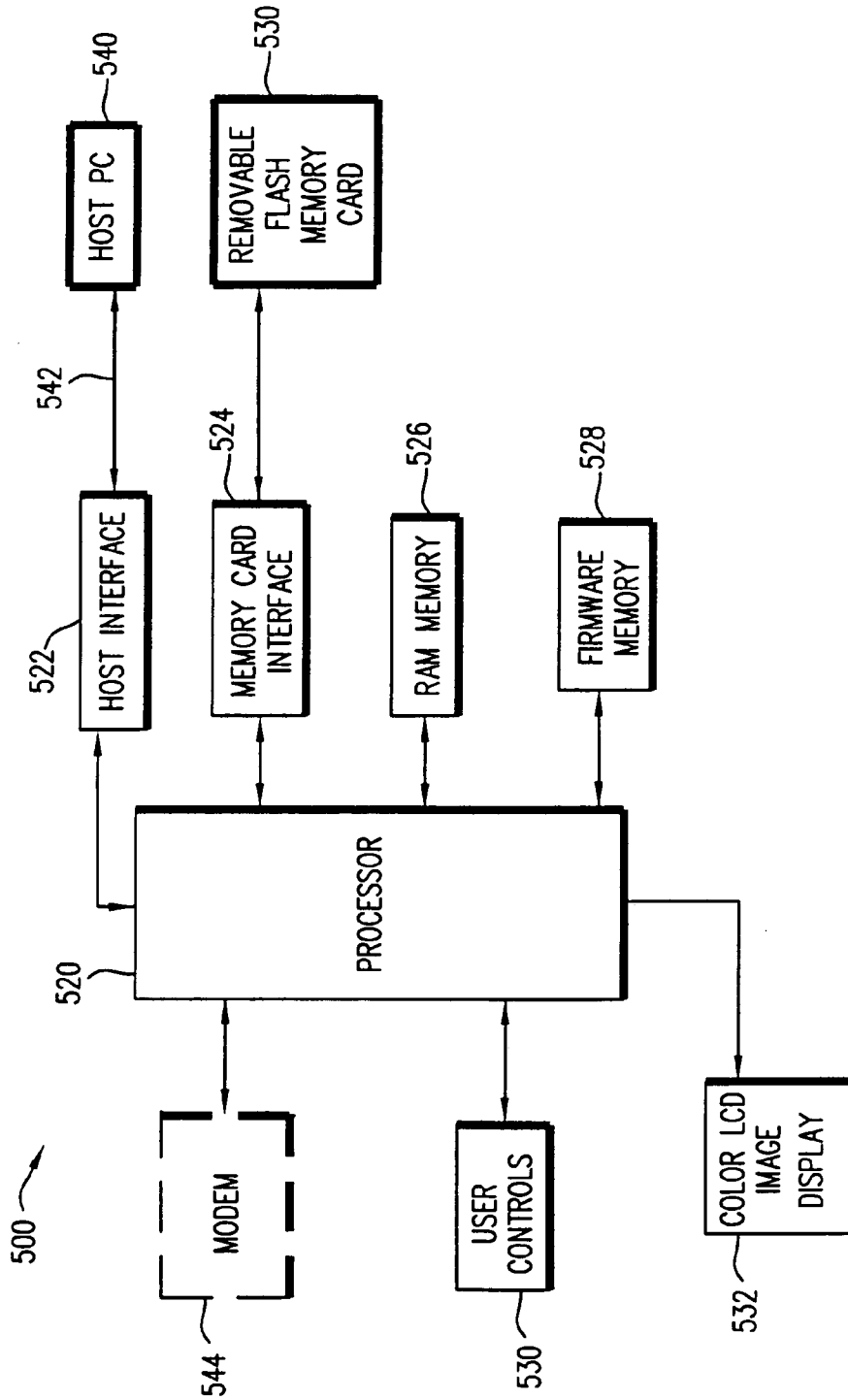
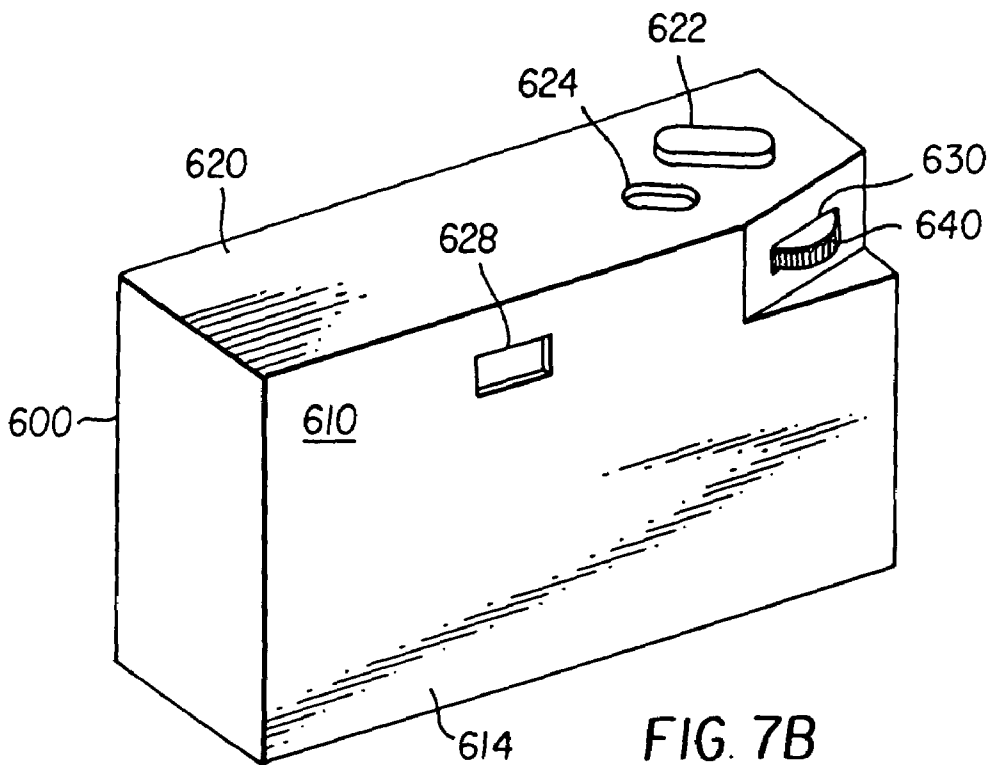
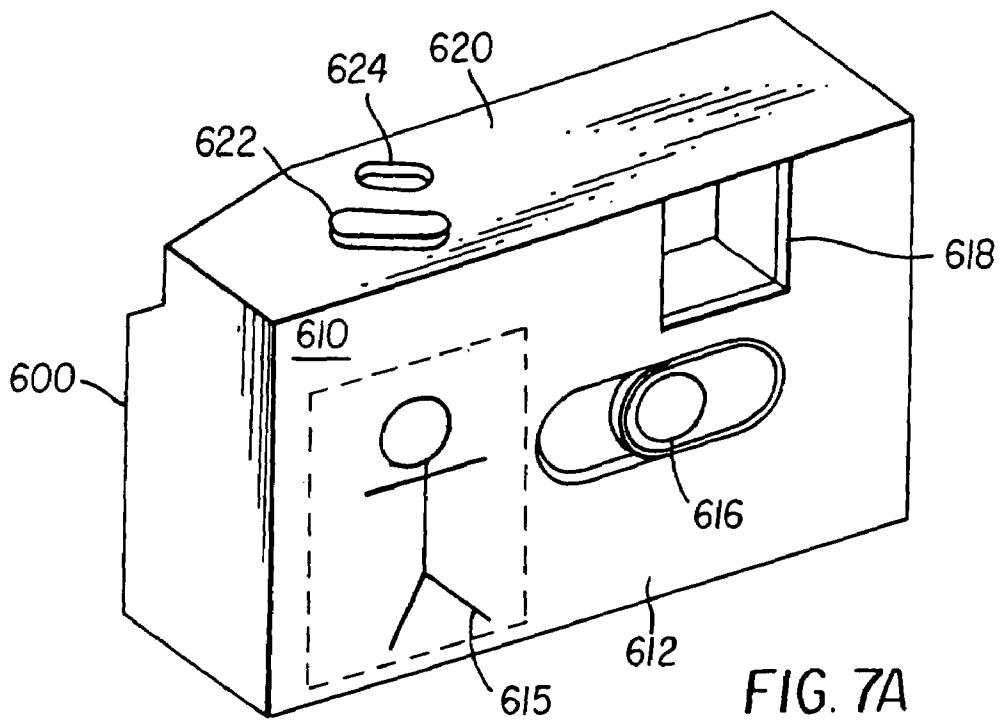

FIG. 6



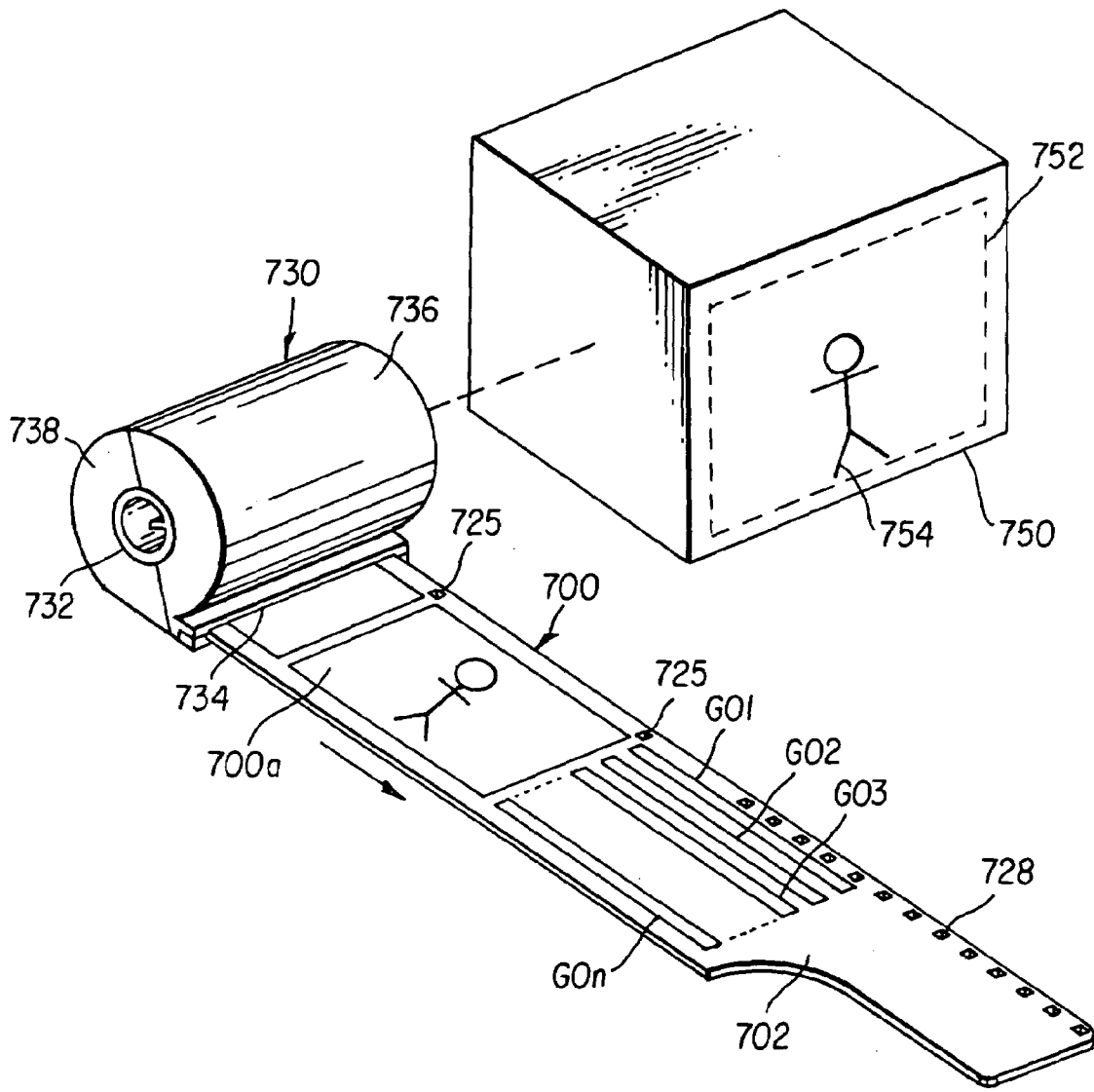

FIG. 8

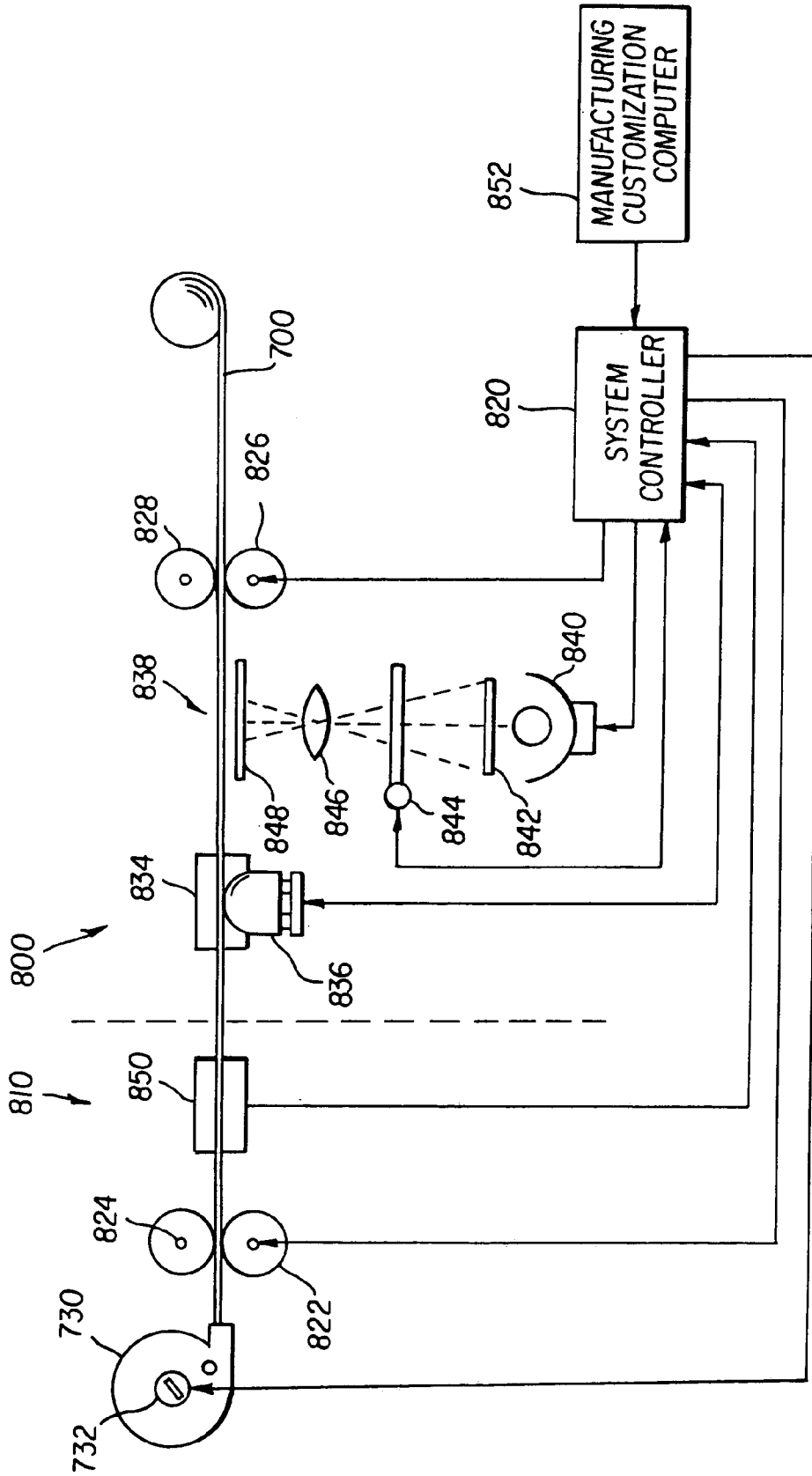

FIG. 9

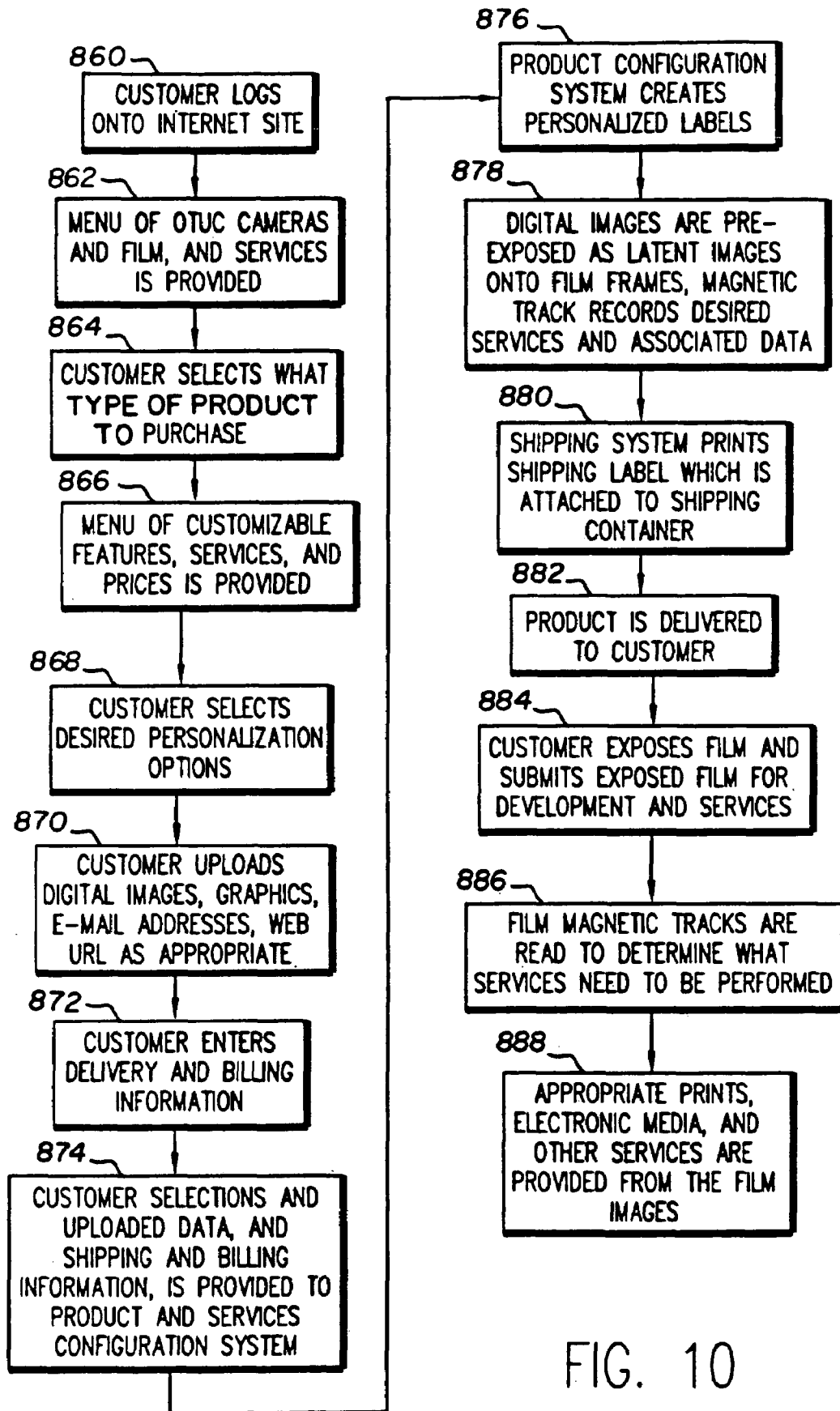

FIG. 10

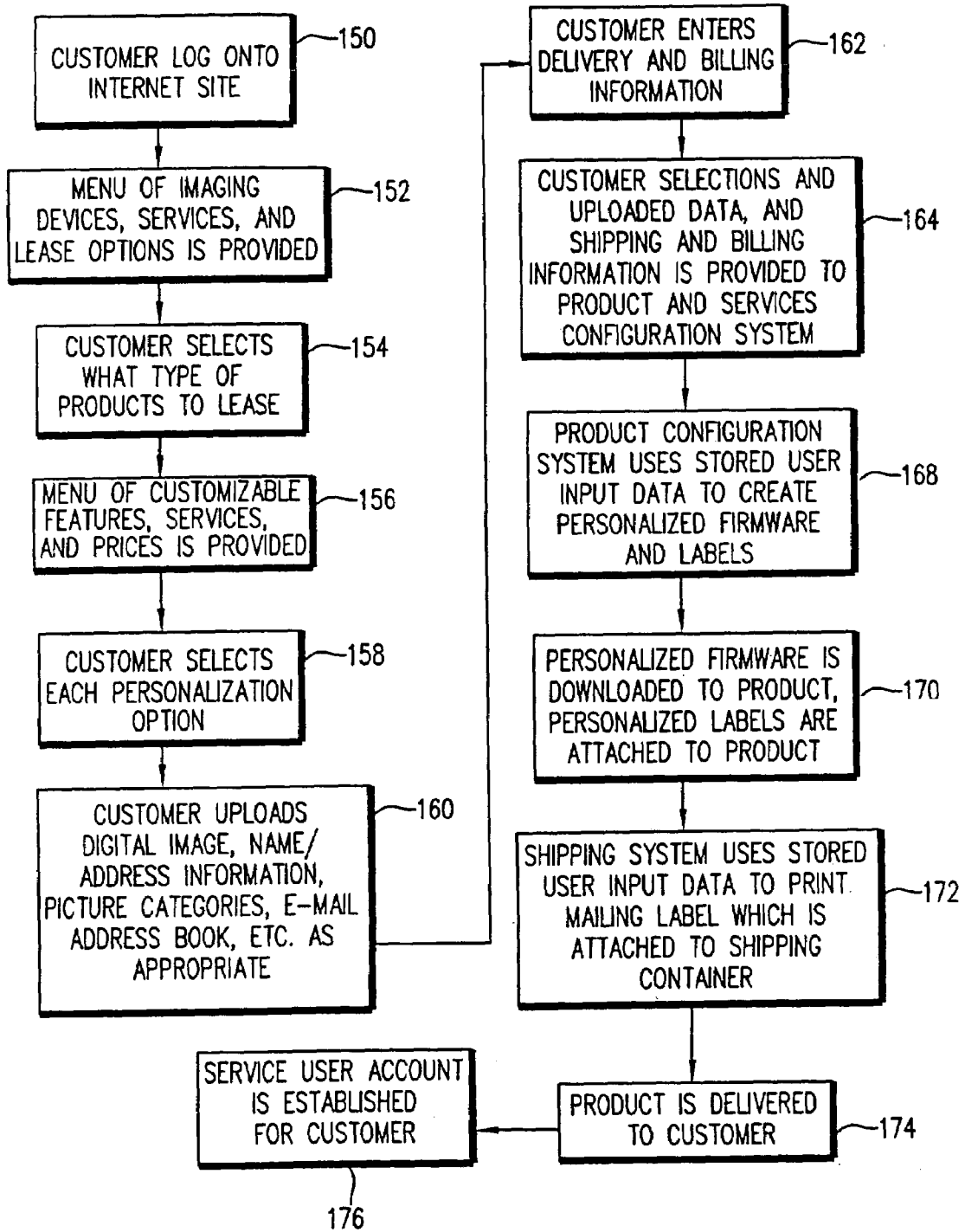

FIG. 11

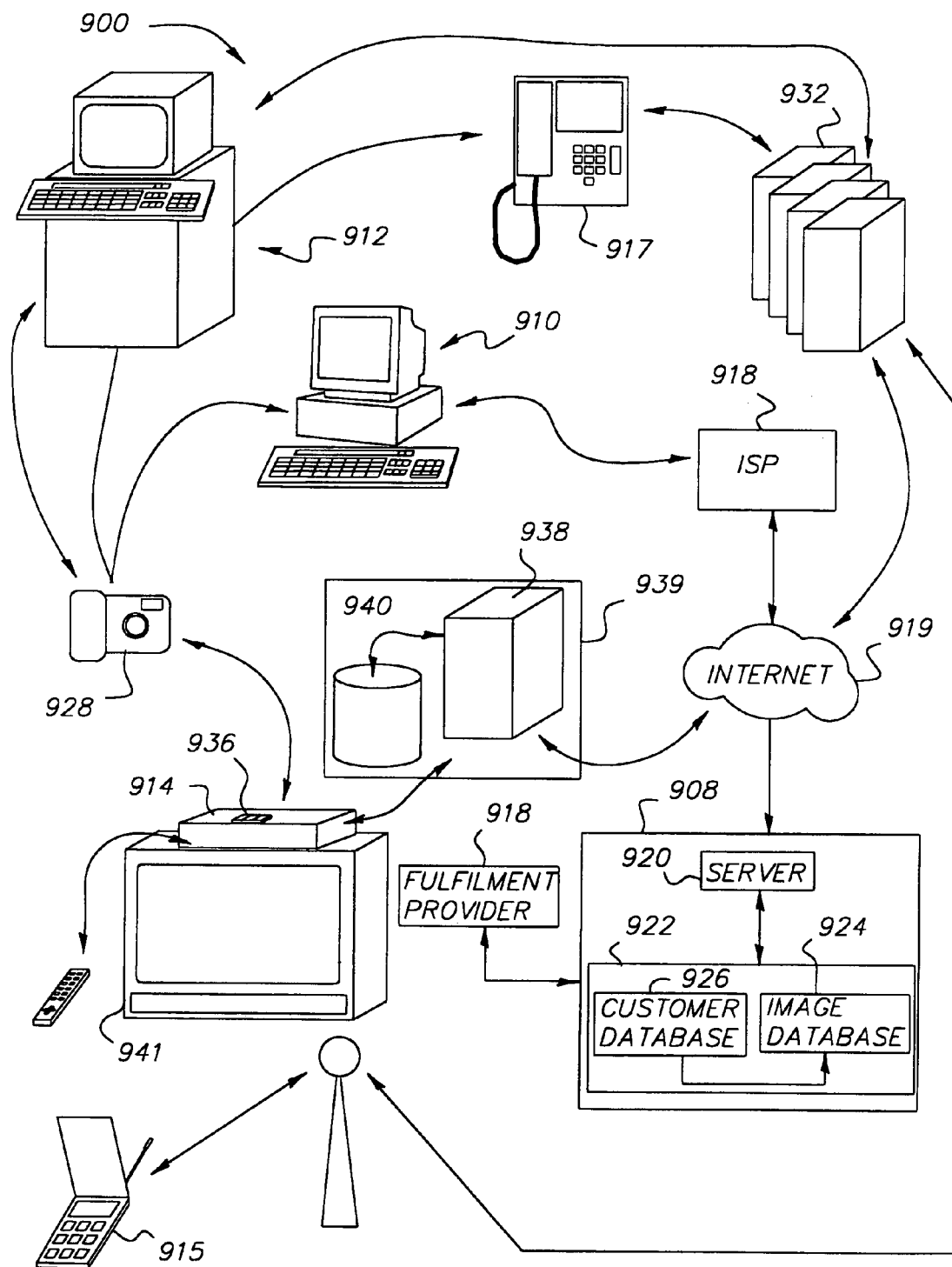

FIG. 12

SYSTEM AND METHOD FOR PROVIDING IMAGE PRODUCTS AND/OR SERVICES

CROSS REFERENCE TO RELATED APPLICATIONS

This is a continuation-in-part of application Ser. No. 09/534,471, filed Mar. 24, 2000, entitled "Leasing A Configured Camera System" to Parulski; and cross references the following.

U.S. patent application Ser. No. 09/534,469, filed Mar. 24, 2000, entitled "Configuring and Purchasing Imaging Devices" to Parulski;

U.S. patent application Ser. No. 09/534,470, filed Mar. 24, 2000, entitled "Purchasing Configured Photographic Film Products" to Parulski;

U.S. Provisional Patent Application Ser. No. 60/137,078, filed Jun. 2, 1999 entitled "Method and Apparatus for Providing a User Customizable Digital Camera" to Girish Prabhu et al., and

U.S. Ser. No. 09/574,950, filed May 19, 2000, entitled "A Method For Providing Image Goods And/Or Services"; to Dale F. McIntyre et al.

FIELD OF THE INVENTION

The present invention relates to a system and method of bundling image capture and printing technologies into products and/or services that are paid for by a user, consumer or customer with a subscription fee. More specifically, the present invention relates to a system and method of providing photographic services, in which a selected and/or specially configured camera and a selected photographic product/service associated with the camera is provided. The present invention also includes using the Internet or other electronic network for the purchasing or registration of such goods and services.

BACKGROUND OF THE INVENTION

Digital cameras, film cameras, printers, and other imaging devices can be purchased in stores or over the Internet from the Eastman Kodak Company at kodak.com or other web sites. The web site may provide text, pictures, and even animated graphics describing and comparing various product models. However, the same standard product, defined by the stock keeping unit (SKU), is shipped to everyone who decides to buy that particular product.

Some products (such as golf shirts) that can be ordered over the Internet, or via phone or the U.S. mail service, can be ordered in a particular color with a personalized monogram or name. In this case, the letters of the monogram/name are sent to the location where the shirt is personalized, where the letters are manually loaded into a sewing machine that physically stitches the monogram into the shirt.

U.S. Pat. No. 5,960,411 discloses an arrangement for ordering merchandise over the Internet. Computers can also be ordered over the Internet. See, for example, the Dell computer Internet site at www.dell.com. Using this site, different configurations of a Dell computer can be purchased. The customer can buy a "standard" configuration of a particular model computer, or can instead select (using pull-down menus) various options. A "learn more" link next to each option enables the user to understand the differences between these options in order to select the most appropriate option. Prior art patents related to customizing computer systems include U.S. Pat. No. 5,894,571, U.S. Pat. No.

5,995,757 and U.S. Pat. No. 5,991,543, and U.S. Pat. No. 5,963,743. These patents relate to ordering selected equipment over the Internet, but the equipment that is produced is defined entirely by the user selections from pre-existing menus. The user does not upload personal data or digital images that are used to personalize the computers or other merchandise.

A digital camera system, described in commonly-assigned U.S. Patent Application Ser. No. 60/137,078, filed Jun. 2, 1999 entitled "Method and Apparatus for Providing a User Customizable Digital Camera", the disclosure of which is herein incorporated by reference, includes the ability to download, from the Internet, special software components that can be used to "upgrade" a camera to provide personalized capabilities, or to personalize a camera in a retail store as the camera is sold.

The ability to customize a camera after purchase using a memory card (for example, by providing a template background into which an image is placed) is described in commonly-assigned U.S. Pat. No. 5,477,264 to Sarbadhikari et al., the disclosure of which is herein incorporated by reference.

The ability to provide camera defect data from a camera manufacturing site over a network to an interactive control node which corrects images provided by a digital camera is described in U.S. Pat. No. 5,606,385, to Maurinus et al.

Commonly-assigned U.S. Pat. No. 5,758,216 to Arnold, the disclosure of which is herein incorporated by reference, describes a single use camera having pre-exposed latent images of symbols that are combined with captured images.

On a web page found at <http://www.bestcameras.com/> a user can order single-use cameras in a variety of cover designs. The user can call a phone number posted at the web site and have a template mailed to the user in Adobe Illustrator format. The user can modify the design in the template and mail back the file, where it can be printed and attached to the outside case of a single use camera. The user can also order single use cameras on-line. The user can choose between several printed paper cover style options, and can personalize the cover with a text message imprinted using the color of text that he or she selects.

The camera company (<http://www.thecamera.co.uk>) enables a user to order customized single use cameras. The customer mails the company logo, photographs, or other literature to the company, which designs a camera for the customer, having a customized printed paper cover for a group of cameras.

Digital cameras are also increasingly being improved with respect to picture quality and image storage. These improved digital cameras, and the products and services associated with the cameras can in some cases be prohibitively expensive. The conventional approach to the purchase of cameras and photographic products/services does not provide a cost efficient and convenient way to obtain and use a variety of cameras, such as high end, high priced digital cameras, while at the same time taking advantage of the vast array of photographic products and services which are available.

Further, the conventional approach to photography and the purchasing of cameras and associated products and services, does not give a consumer the opportunity to bundle and customize specific photographic products and/or services with a selected camera for a specified fee and time; and the further opportunity to keep the camera at no cost, exchange the camera for a new camera or purchase the camera at a reduced rate at the end of a predetermined time period.

It has also become increasingly popular to share digital images, particular over the internet. However, this has been limited to individuals having relatively expensive computers for the capture and/or transmission of digital. In addition when such personal computers are used, the digital data files are transmitted over standard phone lines. Transmission over conventional phone lines generally takes substantial amounts of time to due to the limited capacity of the typical phone lines. Thus there is a need to expand the number of individuals that accept and transmit digital images without requiring substantial investment in equipment such as personal computer.

SUMMARY OF THE INVENTION

The present invention provides for a system and method of providing photographic products and/or photographic services to a consumer. With the system and method of the present invention, a consumer has the option of selecting a camera from among a selection of cameras, for example, a menu of cameras, and further to select a type of photographic service which the user wants associated with the selected camera to create a photographic product and/or photographic service plan. The photographic product and/or photographic service plan would be in the form of a subscription or contract, and would be set for a predetermined time, for example, one year, and at a predetermined fee, for example, a monthly fee. As an example, under the photographic product and/or photographic service plan, the consumer would use the selected camera for a year, and be offered the selected photographic services and/or photographic products for images captured by the camera, either for a monthly fee or a yearly fee. As a further option, after the expiration of the photographic service plan, the consumer can either keep the selected camera at no cost, purchase the camera at a reduced price, or exchange the camera for a new camera.

The present invention further relates to a method of providing photographic products and/or photographic services to a consumer which comprises the steps of selecting a camera and photographic products and/or photographic services which are to be associated with the camera for a predetermined time period, such that the photographic products and/or photographic services are provided to images captured by the selected camera; and maintaining an account of the photographic products and/or photographic services as the photographic products and/or photographic services are provided to the consumer.

The present invention further relates to a method of providing photographic products and/or photographic services which comprises the steps of selecting a camera and photographic products and/or photographic services which are to be associated with the camera for a predetermined time period, such that the photographic products and/or photographic services are provided to film exposed by the selected camera; and maintaining a record of photographic products and/or photographic services as the photographic products and/or photographic services are provided to a user.

The present invention further relates to a system for providing photographic products and/or photographic services which comprises a photographic product and/or photographic service input station into which information with respect to a selected camera and a selected photographic product and/or photographic service plan which is to be associated with the selected camera for a predetermined period of time is input. The photographic product/service input station creates a user product and/or photographic

service account for a user indicative of the selected camera and the selected photographic product and/or photographic service plan. The system further comprises a computer database unit operationally associated with the photographic product and/or photographic service input station that receives and stores the information with respect to the selected camera and the selected photographic product and/or photographic service plan. The computer database unit is adapted to update the user product and/or photographic service account as photographic products and/or photographic services in accordance with the selected photographic product and/or photographic service plan are requested and completed.

The present invention further relates to a method of providing photographic products and/or photographic services to a plurality of different consumers, the method comprising the steps of:

each of the plurality of different consumers selecting product and/or photographic service plan, the plan including a camera and photographic products and/or photographic services which are to be associated with the camera for a predetermined time period, wherein the photographic products and/or photographic services are provided to images captured by the selected camera; and

maintaining for each of the plurality of different consumers an account of the photographic products and/or photographic services at a service provider, each of the accounts having an unique customer ID, the account being accessible from a single input station.

BRIEF DESCRIPTION OF THE DRAWINGS

FIG. 1 depicts a block diagram of a system that implements this invention;

FIG. 2 is a flow diagram of a typical purchase transaction for providing personalized digital imaging products;

FIG. 3 is a block diagram of an electronic still camera that can be personalized as part of the purchase transaction;

FIG. 4 is a block diagram of an APS film camera that can be personalized as part of the purchase transaction;

FIG. 5 is a block diagram of a digital printer that can be personalized as part of the purchase transaction;

FIG. 6 is a block diagram of a digital image display device that can be personalized as part of the purchase transaction;

FIG. 7 depicts a one-time use film camera that can be personalized as part of the purchase transaction;

FIG. 8 depicts a pre-exposed image on the film used in the camera of FIG. 7 or sold as a separate film box;

FIG. 9 is a block diagram of apparatus used to personalize the one-time use film camera depicted in FIG. 7;

FIG. 10 is a flow diagram of a typical purchase transaction for providing the personalized one-time use cameras depicted in FIG. 7 using the apparatus depicted in FIG. 9;

FIG. 11 is a flow diagram of a typical lease transaction for providing personalized digital imaging products and services; and

FIG. 12 depicts a block diagram of a modified system made in accordance with the present invention.

DETAILED DESCRIPTION OF THE INVENTION

In accordance with the present invention, a method is described for configuring cameras or other imaging devices. A customer, such as a purchaser or lessor, selects various camera features, provided by corresponding software pro-

5

grams. The software programs can be, for example, various firmware modules executed by a processor that controls the imaging device. The customer provides a payment identifier, such as a credit card or debit card number, specifying an account to be debited to pay for the camera. A camera configured to include the features selected by the customer, provided by the corresponding software programs, is then sent to a designee of the customer. The customer's designee can, of course, be the customer.

In accordance with another embodiment of the present invention, a customer selects various camera features and imaging services. Such services can include storing digital image files from the selected camera on-line, or producing digital prints or digital storage products (e.g., CD-R discs) from digital images from the selected camera. The customer completes a lease agreement and provides a payment identifier. A camera configured to include the features selected by the customer is then sent to a designee of the customer, and a service account is established to specify the selected services that the designee is entitled to use.

In accordance with another embodiment of the present invention, the customer also provides personal digital data identifying the designee. This personal digital data can include ASCII text providing the designee's name, mailing address, phone number, or e-mail address, and a digital image of the designee. This digital data is then stored in the digital imaging device and can be displayed to determine the owner, in case the digital imaging device is lost or stolen.

In accordance with another embodiment of the present invention, the customer orders a lot of one-time use (OTU) cameras or a lot of film rolls, for a particular event with which the customer is associated. The lot can, for example, include several thousand film rolls for an event such as the Rose Bowl parade or a few dozen OTU cameras for an event such as an anniversary party. The customer provides one or more digital images, which are then pre-exposed onto the first film frame(s) of the film in the OTU cameras, or the film rolls. The customer can also provide images, graphics, or text messages which are included on a label attached to the OTU camera.

As shown in FIG. 1, the system includes a computer (and associated peripherals) **10** located at the customer, such as the purchaser or lessor's location (e.g., their home). The system also includes a network service provider, such as Internet service provider (ISP) equipment **30** located at the ISP's location, which communicates with the computer **10** to provide a network connection for the purchaser/lessor to a channel **36**, such as the Internet. The system further includes a product customization center **40** which communicates with the computer **10** via the channel **36** and the ISP **30** to perform the steps of selecting, configuring, purchasing, billing, and shipping a customized imaging device **80**. The product customization center **40** includes an electronic database **44**, which is located remote from the computer **10**.

The products to be customized (e.g., the digital cameras to be customized) can be manufactured or assembled at the product customization center **40**. Alternatively, they can be manufactured at a different location, and shipped to the product customization center **40** where they are customized. The various portions of the product customization center **40** can be located in a single building or complex of adjacent buildings, or can be geographically disbursed over several sites in different cities or even different continents. For example, the electronic database **44** and a manufacturing customization computer **52** can be located in different cities and interconnected via a suitable digital communications

6

network, such as the Internet. Furthermore, the electronic database **44** can itself be distributed over several computers in several different locations.

The computer **10**, which can be, for example, a Dell Dimension XPS M200, includes a CPU motherboard **12**, using, for example, a Pentium 200 MHz MMX processor as well as RAM memory. The CPU motherboard **12** executes software stored on a hard drive **20**, for example, the well-known Windows 98 operating system software and the Internet Explorer web browser software, both provided by Microsoft Corp. of Redmond, Wash. The CPU motherboard **12** is directly coupled to a display monitor **14** and a keyboard **16**. A mouse **18** permits the customer to readily communicate with the CPU motherboard **12**. The CPU motherboard **12** communicates with a color scanner **24**, such as a Microtek ScanMaker E6, which can scan a photograph, for example, a picture of the customer or the designee of the customer, and store the digital image of the photograph on the hard drive **20**. The customer's computer **10** also includes a dial-in modem **22** for communicating with the ISP **30** in order to connect to a channel **36**, such as the Internet.

The ISP **30**, for example, Earthlink Network, Inc. of Pasadena, Calif., includes banks of modems **32**, one of which is connected to communicate with the modem **22** of the customer's computer **10**. The modem **32** in turn communicates with computers/routers **34** in order to provide a connection to the channel **36** using equipment and techniques well known to those skilled in the art.

The product customization center **40** is connected to the channel **36**, such as the Internet, by a network server, such as Internet server **42**, which is comprised of one or more computers and associated peripherals. The electronic database **44** provides information describing numerous imaging devices **80**, such as digital cameras, APS film cameras, digital printers, image display devices, and the like. The electronic database **44** includes information describing different features of these devices that can be selected and customized by the customer using the customer's computer **10**.

The electronic database **44** further includes software programs, for example, JAVA applets, MPEG or QuickTime movies, or Shockwave files, which depict the functionality of features that the customer can choose. The software programs may demonstrate features, such as in-camera red-eye removal using images provided as part of the electronic database **44**. In this case, the program shows a "before processing" picture having red-eye, and an "after processing" picture which has been processed to remove red-eye. Alternatively, the software program may demonstrate features using customer supplied images, such as images provided using the scanner **24**. In this case, the user can observe the effects of the feature, such as red-eye removal, using their personal images in order to better judge the value of a particular feature. The "before" picture is supplied by the user, and the "after" picture is processed using software supplied by the electronic database **44**. This software can process the image on the user's host computer **12** by using, for example, a JAVA applet. Alternatively, the user's image may be transferred via the ISP **30** and the channel **36** to the Internet Server **42** and processed. The "after processing" image can then be transferred from the Internet Server **42** to the user's computer **10** for viewing on the display monitor **14**.

The electronic database **44** can be contained on the same computer as the Internet server **42**, or can utilize a separate computer, or can be distributed over several computers at the same physical site, or at different sites.

When a customized imaging device **80** is purchased, the electronic database **44** communicates with a billing system **46** to verify that the payment identifier (e.g., credit card or debit card number) provided by the customer is valid, and to debit the account for the purchase. The customer's account that is debited can, of course, be located at a remote financial institution. Typically, as with credit cards, this financial institution will make payment to the direct provider or seller of the imaging device **80**. This is generally done by wiring the amount into the direct provider's account, generally an account established with another financial institution.

As shown in FIG. 1, the electronic database **44** is connected to a manufacturing customization computer **52** that forms part of a product configuration system **50**. The product configuration system **50** provides and downloads software programs, such as customized firmware modules, to the imaging devices **80** in order to configure the imaging devices **80** to provide the customer selected features. The firmware downloaded to a particular digital imaging device **80** includes firmware selected from a product firmware database **54** in response to purchaser/lessor selections, and personal digital data provided by the customer, such as name and address information, or a digital picture. The manufacturing customization computer **52** is also connected to a product label printer **58** which produces custom product labels **60** which can be affixed to the imaging devices **80**.

The manufacturing customization computer **52** also communicates with a shipping system **70** that controls a shipping label printer **72** to produce a shipping label **74**. The shipping label **74** is attached to a shipping container (e.g., a cardboard box) that contains and protects the properly configured imaging device **80** during shipment (e.g., via air express mail, ground carrier, etc.) to the customer's designee.

Turning now to FIG. 2, there is shown a flow diagram of a typical purchase transaction for providing personalized digital imaging products. As shown in block **100**, the customer, using a digital communication network, logs onto the channel **36**, which can be the Internet. The customer can, of course, use a service provider, such as the ISP **30**, to gain access to the channel **36**. The ISP **30** uses an address, such as an Internet protocol (IP) address, to establish a connection between the customer's computer **10** and a product provider or seller which owns or controls the product customization center **40**.

In block **102**, the product provider provides the customer with a menu of imaging devices **80** that are available for configuration, such as an electronic camera **300** depicted in FIG. 3, a film camera **350** depicted in FIG. 4, a digital printer **400** depicted in FIG. 5, and a digital image display device **500** depicted in FIG. 6.

In block **104**, the customer selects a desired type of imaging device **80** to be purchased, for example, the electronic camera **300**. At that point, in block **106**, a menu of customizable features that can be selected, and corresponding prices, is presented to the customer. In block **108**, the customer customizes the features of the desired electronic camera **300** so as to select a desired configuration for the electronic camera **300**.

The features from which the customer can select may include features such as:

Configuring the electronic camera **300** to provide different types of color images, such as monochrome, sepia, false-color, or super saturated color images or special effects filters (e.g., a digital star filter effect);

Configuring the electronic camera **300** to support various image resolution or compression levels, compression algorithms, or image file formats;

Configuring the electronic camera **300** to provide the ability to modify captured images as they are processed, such as by digital zooming and cropping, tone or color adjustments, or sharpness adjustments;

Configuring the electronic camera **300** to provide red-eye removal as described in commonly-assigned U.S. patent application Ser. No. 09/290,290, filed Apr. 13, 1999 to Fredlund, the disclosure of which is herein incorporated by reference;

Configuring the electronic camera **300** to provide the ability to select one or more border templates that may be combined with newly captured digital images, as described in commonly-assigned U.S. Pat. No. 5,477,264 to Sarbadhikari et al., the disclosure of which is herein incorporated by reference;

Configuring the electronic camera **300** to group images into various categories or folders, as described in commonly-assigned U.S. Pat. No. 5,633,678, the disclosure of which is herein incorporated by reference;

Configuring the electronic camera **300** to provide print ordering from the camera, as described in commonly-assigned U.S. patent application Ser. No. 08/977,382, filed Nov. 24, 1997 to Parulski, the disclosure of which is herein incorporated by reference;

Configuring the electronic camera **300** to provide the ability to stitch multiple images together to produce panoramic images, such as by using the method described in commonly-assigned U.S. patent application Ser. No. 09/224,547, filed Dec. 31, 1998 to Parulski, the disclosure of which is herein incorporated by reference;

Configuring the electronic camera **300** to make selected sounds, such as making funny noises as pictures are taken or as various user controls **303** are depressed. One or more sound files can be selected from a group of sound files provided as part of the customization software. For example, one particular sound file can be played each time the capture button is depressed to take a picture, and a different sound file can be played each time a user interface button is depressed when reviewing captured pictures;

Configuring the electronic camera **300** to include "slide show" capability for automatically reviewing the image on color LCD image display **332** for a selected period (e.g., five seconds per image) including selected "transition" effects (e.g., fades or pulls) from one image to the next;

Configuring the electronic camera **300** to upload, from the user's computer **10** to the electronic camera **300**, particularly memorable personal images which are stored within firmware memory **328** to enable viewing by others via the color image display **332**;

Configuring the electronic camera **300** to composite multiple images together, for example, using the method and apparatus described in commonly-assigned U.S. Pat. No. 5,914,748 to Parulski, the disclosure of which is herein incorporated by reference;

Configuring the electronic camera **300** to create html files to produce web pages in the electronic camera, or to provide the ability to e-mail images from the electronic camera, for example, as described in commonly-assigned U.S. patent application Ser. No. 09/004,046, filed Jan. 7, 1998 to Ward, the disclosure of which is herein incorporated by reference;

Configuring the electronic camera **300** to store personal digital data, such as the name, address, and a digital image of the camera owner, in an area of firmware memory **328** (shown in FIG. 3) that cannot be modified by the customer. This information can be displayed on an image display **332** (shown in FIG. 3), such as a color liquid crystal display (LCD), for a specified period (e.g., five seconds) when the

electronic camera **300** is turned on. Alternatively, it can be displayed when the appropriate “camera owner information” mode is selected using user controls **303** in conjunction with a graphical user interface (GUI) displayed on the image display **332**; and

Configuring the electronic camera **300** to include custom labels attached to the camera body providing favorite colors, special messages, or images (such as a picture of the customer’s designee, or a favorite logo or cartoon character).

Depending on the features selected, the customer provides appropriate personalization information that will later be incorporated into the configured electronic camera **300** (block **110** of FIG. **2**). Such personalization information can include personal digital data, for example, ASCII text providing the name, mailing address, phone number, or e-mail address of the customer’s designee, or a digital image of the customer’s designee input using the scanner **24** (shown in FIG. **1**) or other forms of digital image input, such as a PictureCD. The personalization information can also include names of people or events to be used to categorize images, an address book of e-mail addresses, preferred colors and styles for graphic user interface (GUI) screens, and preferred menu orderings for selected features, to be displayed on the color LCD image display **332** (shown in FIG. **3**). The personalization information can also include one or more border templates selected by the customer. The personalization information can also be a message from the customer to the customer’s designee. For example, if the purchase is intended as a birthday gift, the personalization information may be the message “Happy 40th Birthday John, from Sue”. This message could be displayed for a few seconds each time the imaging device **80** is turned on. The personalization information can also include the preferred colors, messages, logos, or images for custom product labels **60**.

Depending on the variety of features supported, different versions of electronic camera **300** can be configured by the product configuration system **50**. The different versions can, for example, include different amounts of the firmware memory **328** or use a different capability image processor **320**, depending on the type or quantity of features selected by the customer. The appropriate version of electronic camera **300** is determined by the manufacturing customization computer **52** as part of the process of customizing the imaging device **80**.

In block **112** of FIG. **2**, the customer enters delivery and billing information. This information identifies the customer and the customer’s designee. It includes addresses of both the customer and the customer’s designee. The customer also identifies an account to be debited to pay for the configured electronic camera **300**. Often this will be a credit card having a payment identifier that specifies the account of the customer to be charged or debited. Frequently, this will be in a financial institution. The payment identifier can be a credit card number that specifies a particular credit card account. As used in this specification, a credit card will also include a debit card.

After the product provider or seller verifies the customer’s account and the availability of the selected imaging device **80**, the customer is provided with an electronic agreement form specifying payment and other items such as warranties. If acceptable, the customer typically accepts the agreement by clicking a response box on the graphical user interface of the computer **10**. At this point, the financial institution having the customer’s account indicates to the product provider or seller that funds are available and designates such funds for transfer to the product provider or seller. If

funds are not available, the customer is so advised and may have to use a different payment identifier.

In block **114**, the electronic database **44** provides the product configuration center **50** with the customer’s selected configuration, and the personalization information. This can occur immediately after the customer accepts the agreement, or at some later time if there is a backlog of products to be configured and shipped for other customers, or if the particular product to be purchased is on backorder and not immediately available for customization.

In block **118**, the manufacturing customization computer **52** shown in FIG. **1** provides the particular software programs required to provide the features selected by the customer for the customer’s selected imaging device **80**. The manufacturing customization computer **52** obtains the required software, either in the form of compiled firmware modules or source code routines, from the product firmware database **54**, and incorporates the personal digital data provided by the customer, to configure the personalized firmware for the imaging device **80**. This personalized firmware provides the features selected by the customer in block **108** of FIG. **2** and includes the personalized digital data, such as a digital image of the customer’s designee, uploaded by the customer in block **110**. If the product firmware database **54** includes camera source code, the source code is compiled to produce firmware capable of being executed by image processor **320**, before being downloaded to the electronic camera **300**.

In block **120**, the manufacturing customization computer **52** downloads the configured firmware from block **118** to the imaging device **80** in order to provide a configured imaging device **80**, such as the configured electronic camera **300**. The firmware can be downloaded to the imaging device **80** using an cable interface, such as interface cable **342** shown in FIG. **3**, which connects between a host interface **322** in the electronic camera **300** and a host computer **340**, which in this situation is the manufacturing customization computer **52**. The firmware can, alternatively, be downloaded to the imaging device **80** using a removable memory, such as a removable flash memory card **330** shown in FIG. **3**, which connects to a memory card interface **324** in the electronic camera **300**. These techniques for downloading firmware to an imaging device are further described in commonly-assigned U.S. Pat. No. 5,477,264 to Sarbadhikari et al., the disclosure of which is herein incorporated by reference.

As shown in FIG. **1**, the manufacturing customization computer **52** also controls the product label printer **58** in order to produce the custom product labels **60**. These labels **60** are then attached, for example, by glue or another lamination process, to the configured imaging device **80**. The custom product labels **60** are provided in the color scheme selected by the customer in block **110**, and include any special messages, logos, or images (such as a picture of the customer’s designee, or a favorite logo or cartoon character) provided by the customer.

In block **122**, the shipping system **70**, which communicates with the manufacturing customization computer **52**, controls the shipping label printer **72** to produce the shipping label **74**. As previously described with respect to FIG. **1**, the configured electronic camera **300** or other imaging device **80** is placed in a shipping container (not shown), and the shipping label **74** is attached to the shipping container.

In block **124**, the configured electronic camera **300** or other imaging device **80** is delivered to the customer or the customer’s designee. The term “delivery” means that the configured electronic camera **300** can be shipped to the customer or the customer’s designee by the U.S. Postal

11

Service (USPS) or by a carrier service, such as the United Parcel Service (UPS) or Federal Express. Alternatively, the configured electronic camera 300 can be delivered to a location such as a store where it can be picked up.

FIG. 3 is a block diagram showing the electronic camera 300 in more detail, which is a first type of imaging device 80 that can be personalized by the product configuration system 50 depicted in FIG. 1. The electronic camera 300 produces digital images that are stored on the removable memory card 330. The electronic camera 300 includes a zoom lens 312 having zoom and focus motor drives 310 and an adjustable aperture and shutter (not shown). The zoom lens 312 focuses light from a scene (not shown) on an image sensor 314, for example, a single-chip color CCD image sensor, using the well-known Bayer color filter pattern. The image sensor 314 is controlled by clock drivers 306. The zoom and focus motors 310 and the clock drivers 306 are controlled by control signals supplied by a control processor and timing generator circuit 304. The control processor and timing generator circuit 304 receives inputs from autofocus and autoexposure detectors 308 and controls a flash 302. The analog output signal from the image sensor 314 is amplified and converted to digital data by the analog signal processing (ASP) and analog-to-digital (A/D) converter circuit 316. The digital data is stored in a DRAM buffer memory 318 and subsequently processed by a processor 320 controlled by the firmware stored in the firmware memory 328, which can be flash EPROM memory.

The processed digital image file is provided to a memory card interface 324 which stores the digital image file on the removable memory card 330. Removable memory cards 330 are known to those skilled in the art. For example, the removable memory card 330 can include memory cards adapted to the PCMCIA card interface standard, as described in the *PC Card Standard, Release 2.0*, published by the Personal Computer Memory Card International Association, Sunnyvale, Calif., September 1991. The removable memory card 330 can also be adapted to the CompactFlash interface standard, such as described in the *CompactFlash Specification Version 1.3*, published by the CompactFlash Association, Palo Alto, Calif., Aug. 5, 1998. Other types of digital memory devices, such as magnetic hard drives, magnetic tape, or optical disks, could alternatively be used to store the digital images.

The processor 320 performs color interpolation followed by color and tone correction, in order to produce rendered sRGB image data. The rendered sRGB image data is then JPEG compressed and stored as a JPEG image file on the removable memory card 330. The processor 320 also creates a "thumbnail" size image that is stored in RAM memory 326 and supplied to the color LCD image display 332, which displays the captured image for the user to review. The electronic camera 300 is controlled by user controls 303, such as a series of user buttons including a shutter release (e.g., capture button) (not shown) which initiates a picture taking operation. The graphical user interface displayed on the color LCD image display 332 is controlled by the user interface portion of the firmware stored in the firmware memory 328. The camera user interface can also include a digital-to-analog (D/A) converter and miniature speaker (not shown) which makes audible sounds when a new picture is taken, or when the user changes modes or advances to review the next stored image. The electronic camera 300 can also include a video output driver and connector (not shown) for displaying the captured images on a TV (not shown).

After a series of images have been taken and stored on the removable memory card 330, the removable memory card

12

330 can be inserted into a memory card reader (not shown) in the user's host computer 340, which may be the same as the computer 10 in FIG. 1. Alternatively, an interface cable 342 can be used to connect between the host interface 322 in the electronic camera 300 and the corresponding camera interface in the host computer 340. The interface cable 342 may conform to, for example, the well-known universal serial bus (USB) interface specification.

The electronic camera 300 can alternatively be a motion video camera that captures a series of image frames from the image sensor 314 as well as an audio signal from a microphone (not shown). The image processor 320 then processes and compresses the image frames and audio information using a suitable compression method (e.g., MPEG-4 compression) to provide movie files that are stored on the removable flash memory card 330 or different type of digital recording media, such as digital video tape.

As described earlier in connection with FIG. 2, either the removable memory card 330 or the host interface 322 can be used to upload the customized firmware from the manufacturing customization computer 52, when the electronic camera 300 is configured by the manufacturing customization computer 52 of FIG. 1.

FIG. 4 is a block diagram of an Advanced Photo System (APS) film camera 350, which is a second type of imaging device 80 that can be personalized by the product configuration system 50 depicted in FIG. 1. The APS film camera 350 includes a zoom lens 352 controlled by zoom and focus motors 354 and an adjustable aperture and shutter (not shown) for focusing light from a scene (not shown) onto APS film 380. The aperture size and shutter exposure time are controlled by a control processor 364, which also receives inputs from autofocus and autoexposure detectors 356 and controls a flash 358 to emit light when the ambient light level is low. A film transport unit 362 advances the frames of the APS film 380 under the control of the control processor 364. A magnetic writer unit 360 writes digital data to the film leader, and to each frame, of the APS film 380, under the control of the control processor 364. The control processor 364 executes firmware stored in firmware memory 370, which may be Flash EPROM memory, in response to user inputs from user controls 372. The control processor 364 also provides information to an LCD display 374, which can be a data display with one or more lines of alpha-numeric characters, or a monochrome or color raster image display. RAM memory 368 temporarily stores the data which is displayed on the LCD display 374. Film camera 350 can also include a digital-to-analog (D/A) converter and miniature speaker (not shown) which makes audible sounds when a new picture is taken, or when the user depresses various user controls 372.

A host interface 366 is used to upload the configured firmware from the manufacturing customization computer 52 via an interface cable 367, which can be, for example, an RS-232 serial cable, when the APS film camera 350 is configured by the product configuration system 54 of FIG. 1.

The configured firmware stored in the firmware memory 370 can include personal digital data, for example, the name, address, and a digital image of the customer's designee, or a greeting from the customer to the customer's designee. This personal digital data can be displayed on the LCD display 374 for a specified period (e.g., five seconds) when the APS film camera 350 is turned on. Alternatively, it can be displayed when the appropriate "camera owner information" mode is selected using the user controls 372 used in conjunction with the LCD display 374. This personal digital

data can be used to determine the owner, in case the APS film camera 350 is lost or stolen.

The configured firmware stored in the firmware memory 370 can include messages appropriate for various images, such as "Happy Birthday, John", or "Another Picture of the Smith family." These messages are provided by the customer in block 110 of FIG. 2, and downloaded to configure the APS film camera 350 in block 120 of FIG. 2. The message can be selected by the camera user after taking a picture, and can be then recorded as ASCII text data on the magnetic tracks of the APS film 380. When the APS film 380 is developed and printed, the magnetic tracks of the APS film 380 are read to recover this ASCII text message. The text message can then be printed on the back of the print if the print is made by optically printing the APS film 380. Alternatively, the text message can be printed on a front corner of the print if the print is made by scanning and digitally printing the APS film 380.

FIG. 5 is a block diagram of a digital printer 400, which is a third type of imaging device 80 that can be configured by the manufacturing customization computer 52 depicted in FIG. 1. The digital printer 400 produces digital prints (not shown) from images provided on a removable memory card 430 or via a host interface 442 from a host computer 440. The digital printer 400 includes a media transport mechanism 410, such as a motor-driven roller, for moving hard copy media (e.g., ink jet paper) past a marking apparatus 412 (e.g., a color ink jet head) under the control of a processor 420. The processor 420 controls the marking apparatus 412 to provide controlled amounts of various color inks or dyes in order to produce a pictorial image on the hardcopy media.

Digital image files to be printed can be provided on a memory card 430 that interfaces to the processor 420 via a memory card interface 424. The memory card 430 can be adapted to the PCMCIA card interface specification, the CompactFlash specification, or similar specifications. If the image to be printed is supplied in a compressed image format (e.g., JPEG compression), the processor 420 decompresses the image. The processor 420 can also provide interpolation, color and tone correction, half-toning, sharpening, or other types of digital image processing to prepare the image data properly to be used by the marking apparatus 412.

The processor 420 is controlled by firmware stored in firmware memory 428. The digital printer 400 includes a display 432, which can be a simple status display, or which can, alternatively, be a raster image display. If the display 432 is a status LCD, the user selects prints by picture number, or alternatively, by creating a print order file, using, for example, the "Digital Print Order Format" (DPOF) specification, when the pictures are stored on the memory card 430.

If the display 432 is a raster image display, the processor 420 downloads the "thumbnail" size images from the images provided on the memory card 430, which are stored in RAM memory 426 and supplied to the display 432, so that the user can select the images to be printed using user controls 430. The graphical user interface displayed on the display 432 is controlled by the user interface portion of the firmware stored in the firmware memory 428.

The printer 400 can also include a D/A converter and miniature speaker (not shown) which makes audible sounds when a print is finished and ready to be viewed, or when various user controls 430 are depressed. These sound files can be selected by the user in block 108 of FIG. 1, and stored in firmware memory 428. Instead of a raster image display,

the printer can include a video output driver and connector (not shown) for displaying the selected images on a TV receiver (not shown).

Either the removable memory card 430 or the host interface 422 can be used to upload the customized firmware to the firmware memory 428 from the manufacturing customization computer 52 (shown in FIG. 1), as described earlier in connection with FIG. 2, when the digital printer 400 is configured by the product configuration system 50 of FIG. 1.

The configured firmware stored in the firmware memory 428 can include personal digital data, for example, the name, address, and a digital image of the customer's designee, or a greeting from the customer to the customer's designee. If the display 432 is a raster image display, this personal digital data can be displayed on the display 432 for a specified period (e.g., five seconds) when the digital printer 400 is turned on. Alternatively, if the display 432 is a status display incapable of displaying images, the personal digital data can be printed by the marking apparatus 412 onto the hardcopy media (not shown) when the "print camera owner information" mode is selected using the user controls 432 used in conjunction with the status display 432. Alternatively, this personal digital data can be printed as part of a test print mode included to test the operation of the digital printer 400. This personal digital data can be used to determine the owner, in case the digital printer 400, which can be a small portable device, is lost or stolen.

The configured firmware stored in the firmware memory 428 can include firmware that provides various other features, selected by the customer in block 110 of FIG. 2. These features can include:

- Configuring the digital printer 400 to selectively modify the color images to produce different types of digital images before printing, in order to produce monochrome, sepia, false-color, or super saturated color prints;

- Configuring the digital printer 400 to support various image file formats, such as JPEG, TIFF, and JPEG2000;

- Configuring the digital printer 400 to provide the ability to modify captured images as they are processed, such as by digital zooming and cropping, tone or color adjustments, or sharpness adjustments;

- Configuring the digital printer 400 to provide red-eye removal prior to printing images;

- Configuring the digital printer 400 to provide the ability to select one or more border templates that can be combined with the images to be printed, as described in commonly-assigned U.S. Pat. No. 5,477,264 to Sarbadhikari et al.;

- Configuring the digital printer 400 to provide support for printing the images defined in a print ordering file (for example, a DPOF file), as described in commonly-assigned U.S. patent application Ser. No. 08/977,382, filed Nov. 24, 1997 to Parulski, the disclosure of which is herein incorporated by reference; and

- Configuring the digital printer 400 to provide the ability to stitch multiple images together to produce panoramic images, such as by using the method described in commonly-assigned U.S. patent application Ser. No. 09/224,547, filed Dec. 31, 1998 to Parulski, the disclosure of which is herein incorporated by reference.

FIG. 6 is a block diagram of a digital image display device 500, which is a fourth type of imaging device 80 that can be personalized by the product configuration system 50 depicted in FIG. 1. The digital image display device 500 produces an image on a color image display 532, such as a

color LCD, from images provided on a removable memory card 530 or via a host interface 542 from a host computer 540. If the image to be displayed is supplied in a compressed image format (e.g., JPEG compression), a processor 520 decompresses the image. The processor 520 can also provide

decimation to produce an appropriately sized digital image for the color image display 532. The processor 520 can further provide color and tone correction, sharpening, or other types of digital image processing prior to displaying the image.

The processor 520 is controlled by firmware stored in firmware memory 528. The processor 520 creates appropriately sized images that are stored in RAM memory 526 and provided to the color image display 532. The user can select the images to be viewed using user controls 530. The graphical user interface displayed on the color image display 532 is controlled by the user interface portion of the firmware stored in the firmware memory 528. Instead of including a color image display as part of the digital image display device 500, the digital image display device 500 can include a video output driver and connector (not shown) for displaying the selected images on a TV receiver (not shown). The digital image display device 500 can also include a modem 544 for transmitting and receiving images.

Either the removable memory card 530 or the host interface 522 can be used to upload the customized firmware from the manufacturing customization computer 52, as described earlier in relation to FIG. 1, when the digital image display device 500 is configured by the product configuration system 54 of FIG. 1.

The configured firmware stored in the firmware memory 528 can include personal digital data, for example, the name, address, and a digital image of the customer's designee, or a greeting from the customer to the customer's designee. This personal digital data can be displayed on the color image display 532 for a specified period (e.g., five seconds) when the digital image display device 500 is turned on.

The configured firmware stored in the firmware memory 528 can also include firmware that provides various other features, selected by the customer in block 110 of FIG. 2. These features can include:

Configuring the digital image display device 500 to convert color images to different types of images before displaying the images, to provide monochrome, sepia, false-color, or super saturated color images;

Configuring the digital image display device 500 to support various image file formats for the images stored on memory card 530, such as JPEG, TIFF, and JPEG2000;

Configuring the digital image display device 500 to provide the ability to modify captured images as they are processed, such as by digital zooming and cropping, tone or color adjustments, or sharpness adjustments; and

Configuring the digital image display device 500 to transmit or receive images from an electronic network, such as the Internet, using the modem 540, for example, as described in commonly-assigned U.S. patent application Ser. No. 09/004,046, filed Jan. 7, 1998 to Ward, the disclosure of which is herein incorporated by reference.

FIGS. 7A and 7B depict a photographic film product, which is a one-time use (OTU) film camera 600 preloaded with film that can be personalized as part of the purchase transaction. The camera body is formed of plastic and is encased in an exterior camera package 610, to which the custom product labels 60 can be attached, for example, at a position 615. The camera package 610 comprises a main

front cover section 612, a back cover section 614, a top section 620 and side and bottom sections which surround a light-tight, box shaped, camera body. The main front cover section 612 is provided with apertures for exposing a taking lens 616 and a viewfinder window 618 of the enclosed camera body. The top section 620 has a pair of apertures for receiving a shutter release button 622 and for viewing an underlying exposure counter wheel number 624. An aperture for a viewfinder eyepiece 628 is provided in the back cover section 614 for the camera viewfinder window 618. A thumb wheel opening 630 permits a thumb wheel 640 to be exposed to be rotated by the user to advance the filmstrip to the next image frame to be exposed. A film package of this type is available from the Eastman Kodak Company as the Fun Saver 35 and in other similar configurations.

FIG. 8 depicts a pre-exposed image on the film used in the OTU film camera 600 depicted in FIGS. 7A and 7B, or sold as a separate film box. A filmstrip leader 702 and a first image frame 700a of a filmstrip 700 are depicted withdrawn from a film cartridge door 734 of a film cartridge 730. The film cartridge 730 includes a cartridge shell 736 extending between end plates 738 and enclosing a hub 732 in a manner well known in the art. The film cartridge 730 is preferably of the thrust type having a light tight film cartridge door 734 that can be opened to advance the filmstrip 700 out of or back into the film cartridge 730. In this regard, the cartridge hub 732 can be engaged by a drive member (not shown) and rotated in both directions to assist in ejecting or retracting the filmstrip 700 out of and back into the open film cartridge door 734. The various embodiments of the invention can also be practiced with the standard film cartridges of the 35 mm type. The filmstrip leader 702 includes closely spaced perforations 728 for automatic film advance mechanisms used in cameras. The filmstrip 702 includes magnetic tracks G01-G0n which, in accordance with an embodiment of the present invention, are recorded with data identifying specific services to be provided by a photofinisher. It will be understood that the track size, number of tracks, and placement on the filmstrip leader 702 depicted in FIG. 8 are arbitrary and not to scale. One or more image frames, such as frame 700a, are pre-exposed with latent images when the OTU film camera 600 is configured by the product configuration system 50 in FIG. 1. The latent images are produced from digital images supplied by the customer as part of block 870 in FIG. 10.

FIG. 8 also illustrates a further embodiment of the invention, wherein the filmstrip 700 and the cartridge 730 are intended to be used in a reloadable film camera, rather than in a one-time use camera. In this aspect, the filmstrip 700 can be wound into the cartridge 730 and placed in a film package 750 for shipping to retail dealers. In this embodiment, the arrangement including the filmstrip 700 incorporated into the cartridge 730, and the film package 750, is a photographic film product. The film package 750 can be, for example, a box, a canister, or any other suitable container, and can include the graphics, text and colors typically employed to identify the brand, manufacturer, film speed, and type of film in a manner well known in the art. It can also include one or more areas 752 to which the custom product labels 60 can be affixed. The custom product label 60 can include a digitally printed image supplied by the customer as part of block 110 in FIG. 2. The custom product label 60 can also include text indicating the specific services to be provided by the photofinisher.

FIG. 9 is a block diagram of a system used to personalize the OTU film camera 700 depicted in FIG. 7. FIG. 9 includes a magnetic recording subsystem 810 for recording the data

in the magnetic tracks G01–G0n, and a subsystem 800 for making latent image exposures on one or more of the image frames 700a, as part of the process of configuring the filmstrip 700 by the product configuration system 50 of FIG. 1. The system is controlled by a system controller 820 which is in turn controlled by the manufacturing customization computer 52. The filmstrip 700 is partly withdrawn from the cartridge 730 and advanced past a perforation sensor 850. Advancement is effected by commands from the system controller 820 applied to a mechanism for opening the film cartridge door 734 of the film cartridge 730 and rotating hub 732 to eject the filmstrip leader 702 and drive it between a first driven roller 822 and an idler roller 824. A drive roller motor (not shown) rotates the driven roller 822 and the idler motor 824 in a first direction in response to drive signals received from the system controller 820. The filmstrip leader 702 is then advanced between a backing support 834 and a magnetic read/write head 836, and magnetic recording in the tracks G01–G0n is effected by signals applied to the magnetic recording read/write head 836 from the system controller 820. The lengths of the tracks G01–G0n are controlled by signals received from a perforation sensor 850. The specific data recorded in magnetic recording tracks G01–G0n is provided by the manufacturing customization computer 52. After the tracks are recorded, the first drive motor direction is reversed to drive the filmstrip 700 back into the cartridge 730, and the film cartridge door 734 is closed.

The subsystem 800 of FIG. 9 enables the digital images provided by the product configuration system 50 to be exposed on one or more image frames 700a. In order to do so, the filmstrip 700 is advanced in a dark enclosure out of the film cartridge door 734. Then, the filmstrip image frames are advanced an image frame at a time through a latent image exposure station 838 and between the second motor driven roller 826 and the idler roller 828 to present each image frame to be exposed into the exposure gate 848.

The latent image exposure can be produced using various methods. Some customers will purchase a large lot of OTU cameras 600 or packaged film rolls 750 that are to be produced having the same pre-exposed images. For example, several thousand single-use “Packer football” cameras, having a pre-exposed image of quarterback Brett Farve, could be ordered for sale at a Packer football game. In this case, a digital image of Brett Farve would be provided by the customer as personalized digital data as the lot of OTU cameras 600 is purchased. The manufacturing customization computer 52 could connect to a digital hardcopy printer, such as a Kodak XLS 8650 thermal dye sublimation printer (not shown), in order to produce a transparency 842 (in FIG. 9) of the Brett Farve image. The product label printer 58 is used to produce the custom product labels 60 which can include text, for example, “Packer Backer Camera,” and a low resolution image of Brett Farve. The custom product labels 60 are affixed to the OTU camera 600 (at position 615), or the film package (at position 752).

The transparency 842 containing the transparency image to be pre-exposed on the film is illuminated by a light source 840, and the image is projected in focus on the area 700a by an imaging lens 846 when a shutter 844 is opened. The filmstrip 700 is clamped in an exposure gate 848. The exposure is effected through the opening and closing of the shutter 844 which is operated by signals from the system controller 820. Different latent image exposures can be provided using multiple transparencies and a motorized transparency transport system (not shown). After one or more of the image frames 700a are exposed in this fashion,

the motor driven rollers 822 and 826, and the hub 732, are operated in the second direction to retract the filmstrip 700 back into the film cartridge 730. The film cartridge door 734 of the film cartridge 730 is then closed under control of the system controller 820. To prevent re-exposure of the pre-exposed frames, the film is then placed in the OTU camera 600 and the filmstrip 700 is advanced past the pre-exposed frames. When the film cartridge 730 is separately packaged in the film package 750, the magnetic tracks recorded with each film frame indicate which image frames have been pre-exposed, using well-known mid-roll interrupt methods, to prevent re-exposure of the pre-exposed frames.

Some customers will purchase relatively small lots of OTU cameras 600 or packaged film rolls 750. In this situation, instead of using the transparency 842 illuminated by the light source 840, the digital data can be provided directly to a high resolution digital film writer (not shown), such as a monochrome CRT, which focuses a high resolution image through a red, green, and blue color filter wheel and onto the filmstrip 700. Other types of digital film writers, including writers using LCDs and LEDs, can alternatively be used.

FIG. 10 is a flow diagram of a typical purchase transaction for providing the personalized OTU cameras 600 depicted in FIG. 7 using the apparatus depicted in FIG. 9. As shown in block 860, the customer, using a digital communication network, logs onto the channel 36, which can be the Internet as described earlier in relation to block 100 of FIG. 2.

In block 862, the product provider provides the customer with a menu of cameras and film, such as OTU cameras 600 in FIG. 7 and the packaged film 750 in FIG. 8, that are available for customization. The menu can also include a list of services, such as:

- Providing standard optical prints from the film images;
- Providing a CD-R or floppy disk with the digitized film images;
- Uploading the digitized film images to a web site provided by the product provider, or alternatively, a web site designated by the user; and
- E-mailing the images to one or more e-mail addresses provided by the user.

In block 864, the customer selects what type of product to purchase, and the desired quantity. At that point, in block 866, a menu of customizable features that can be selected, and corresponding prices, is presented to the customer. In block 868, the customer selects the desired features of the product they decide to purchase.

The features from which the customer can select may include:

- Providing text, graphics, or digital images to create custom labels that are affixed to the OTU camera 600 in FIG. 7 or the film package 750 in FIG. 8;
- Providing one or more digital images to be pre-exposed on the film contained within the OTU camera 600 in FIG. 7 or the film package 750 in FIG. 8;
- Identifying, using magnetic tracks G0n in FIG. 8 that the film images should be chemically developed and then optically printed, or digitally scanned and digitally printed to produce one or more service prints for each exposed film frame, having a size (e.g., 3.5"×5", 4"×6") and finish (e.g., glossy, matt) selected by the user;
- Identifying, using magnetic tracks G0n in FIG. 8 that the film images should be digitized and digitally processed to provide a modified image, such as monochrome, sepia, false-color, or super saturated color images, rather than normal color images;

19

Identifying, using magnetic tracks $G\phi n$ in FIG. 8 that the film images should be digitized and stored on a digital media selected by the user, such as a floppy disk or PictureCD;

Identifying, using magnetic tracks $G\phi n$ in FIG. 8, that the film images should be digitized and digitally processed to combine a border template with the film images, as described in commonly-assigned U.S. Pat. No. 5,758,216 to Arnold, the disclosure of which is herein incorporated by reference;

Identifying, using magnetic tracks $G\phi n$ in FIG. 8, that the film images should be digitized and the digital image files should be uploaded to the Internet to a prescribed Internet URL (Universal Resource Locator) provided by the customer, or to a service account provided by the product provider;

Identifying, using magnetic tracks $G\phi n$ in FIG. 8, that the film images should be digitized and the digital image files should be e-mailed to one or more e-mail addresses provided by the customer; and

Identifying, using magnetic tracks $G\phi n$ in FIG. 8, personal digital data, such as the name, address, or copyright notice of the camera owner. This information can be printed on the front or back of prints produced from the exposed film.

Depending on the features selected, the customer uploads the necessary digital images, graphics, name, copyright notice, e-mail addresses, or web URLs (block 870). The personalization information can also include an identifier for one or more border templates that can be provided by the product provider. For example, the customer may be a bride ordering several dozen OTU cameras for a wedding. The bride can upload a digital image of the wedding couple, to be used to produce the custom product labels 60 along with a text message "John and Sue, Jan. 28, 2000". The bride can select two 4x6 digital prints of each image made, and also select a border template having a wedding motif from a selection of border templates displayed in block 866. The template can be further personalized by adding the same text message "John and Sue, Jan. 28, 2000", or a different message. The bride can also decide to have a digital image file produced from each film frame and uploaded to a web site provided by the service provider, which can later be viewed by all the wedding guests.

In block 872, the customer enters delivery and billing information. This information identifies the customer and the customer's designee, as described earlier in relation to block 112 of FIG. 2. In block 872, the electronic database 44 provides the product configuration center 50 with the customer's selected configuration, and the personalization information.

In block 876, the manufacturing customization computer 52 controls a product label printer 58 in order to produce the custom product labels 60. These custom product labels 60 are then attached, for example, by glue or another lamination process, to the OTU camera 600 in FIG. 7 or the film package 750 in FIG. 8. The custom product labels 60 are provided in the color scheme selected by the customer in block 870, and include any special messages, logos, or images provided by the customer.

In block 878, the digital images are pre-exposed as latent images onto the film frames 700, and the magnetic tracks $G\phi n$ of the film frames are recorded, as described earlier in relation to FIG. 9. The information recorded in the magnetic tracks identifies the services selected in block 868. For example, it identifies what quantity, size, and finish hard copy prints have been selected. It further identifies whether

20

a template border file should be used, and if so, the identification number of the selected border and any text message that should be included in the border file. It further identifies whether the film images should be scanned and provided as digital files on a particular media, or uploaded to a web site or e-mailed to one or more addresses. In one embodiment of the present invention, all of this information is stored using the magnetic recording tracks Gn . In another embodiment, only an identification number is stored using the magnetic recording tracks Gn , or alternatively, using a bar code or other identification number on the OUT camera 600. This identification number is used to access a corresponding services file stored in the electronic database 44. When the filmstrip 700 is later developed, this identification number is read and used to access the appropriate services file to determine what services and customization options (e.g., border files) have been purchased by the customer.

In block 880, the shipping system 70, which communicates with the manufacturing customization computer 52, controls the shipping label printer 72 to produce the shipping label 74. The customized group of OUT cameras 600 or the packaged films 750 is placed in an appropriately sized shipping container (not shown), and the shipping label 74 is attached to the shipping container. In block 882, the shipping container is delivered to the customer or the customer's designee.

In block 884, the customers expose the film as in normal picture-taking, and submit the exposed film, or completely used OTU cameras 600, for development and services. This can be accomplished by mailing the film cartridges 730 or the OTU cameras 600 back to the product provider, or by taking the film cartridges 730 or OTU cameras 600 to a retail establishment associated with the product provider.

In block 886, the film magnetic tracks are read to determine the services that need to be provided. As described earlier in relation to block 878, this is done either by directly reading the services encoded as magnetically recorded information on the filmstrip 700, or alternatively, by reading the identification number recorded in the magnetic track or the bar code or ID number on the OUT camera 600 and using this identification number to access a corresponding services file stored in electronic database 44, to determine what services and customization options have been purchased by the customer. In block 888, the appropriate prints, electronic media, and other services purchased by the customer are provided from the developed film images.

FIG. 11 is a flow diagram of a typical lease transaction for providing personalized digital imaging products and services. In this embodiment, a customer leases a digital imaging device, such as the electronic camera 300. The lease can include, for example, a monthly fee for the use of both the electronic camera 300 and the use of services associated with the electronic camera 300. Alternatively, the lease can include payment for services associated with the electronic camera 300 on an as-used basis.

As shown in block 150, the customer, using a digital communication network, logs onto the channel 36 which can be the Internet, as described earlier in relation to block 100 of FIG. 2.

In block 152, the service provider provides the customer with a menu of imaging devices 80 that are available for lease, such as the electronic camera 300 depicted in FIG. 3, the APS film camera 350 depicted in FIG. 4, the digital printer 400 depicted in FIG. 5, and the digital image display device 500 depicted in FIG. 6. The menu can also include a list of services that can be provided.

In block 154, the customer selects a desired type of imaging device 80 to lease, for example, the electronic camera 300. At that point, in block 156, a menu of customizable features and services that can be selected, and corresponding prices, is presented to the customer. In block 158,

the customer selects the personalization options for both the electronic camera 300, as well as the services that can be performed on digital images from the electronic camera 300.

The camera features from which the customer can select include those described earlier in relation to block 108 of FIG. 2. The services that can be provided include:

Digitally printing images produced by the camera to produce one or more service prints for each exposed film frame, having a size (e.g., 3.5"×5", 4"×6") and finish (e.g., glossy, matt) selected by the customer, as well as an optional border template file or back printed information selected by the customer;

Storing the digital images produced by the camera on a digital media selected by the customer, such as a PictureCD;

The service provider storing, and maintaining for a user selected period of time (e.g., 30 days, 1 year, or 10 years), the digital images produced by the camera on an Internet accessible digital storage device, such as on a hard drive connected to an Internet server; and

E-mailing the digital images to one or more e-mail addresses provided by the customer.

Depending on the features selected, the customer provides appropriate personalization information that will later be incorporated into the configured electronic camera 300 (block 160) as described earlier in relation to block 110 of FIG. 2, as well as personalization information for the selected services, such as the ID of the selected template file.

In block 162, the customer enters delivery and billing information, as described earlier in relation to block 112 of FIG. 2. In block 164, the electronic database 44 provides the product configuration center 50 with the customer's selected configuration and personalization information for the selected imaging device 80 and the selected services.

In block 168, the manufacturing customization computer 52 shown in FIG. 1 selects the particular software programs required to provide the features selected by the customer for the customer's selected imaging device 80, as described earlier in relation to block 118 of FIG. 2. The manufacturing customization computer 52 also controls the product label printer 58 in order to produce the custom product labels 60.

In block 170, the manufacturing customization computer 52 downloads the configured firmware to the imaging device 80 in order to provide a configured imaging device, such as a configured electronic camera 300.

In block 172, the shipping system 70, which communicates with manufacturing customization computer 52, controls the shipping label printer 72 to produce the shipping label 74. The configured electronic camera 300 or other imaging device 80 is placed in a shipping container (not shown), and the shipping label 74 is attached to the shipping container. In block 174, the configured electronic camera 300 or other imaging device 80 is delivered to the customer or the customer's designee.

In block 176, a service user account is established for the customer, which defines the services to be provided to the customer. This service account information can be provided as part of electronic database 44, or as a separate digital database. These services can be provided for digital images uploaded by the customer to the service provider via the channel 36, such as the Internet. Alternatively, they could be provided by taking the removable memory 330 from the

electronic camera 300 to a retail establishment associated with the service provider, and providing an appropriate service identifier, such as a service identification number. This service identification number can be stored in the firmware memory 328 of the electronic camera 300 by the manufacturing customization computer 52 when the electronic camera 300 is configured. The service identification number can then be stored onto the removable flash memory 330, either as part of each image file, or as a separate digital record, so that it can be used to automatically access the service account for the user to determine what services should be provided. When desired, the customer can modify the service user account to add additional services and to modify the lease agreement to include the additional services and to provide payment for such services.

A computer program product, such as a readable storage medium, can store the programs in accordance with the present invention for operating the methods set forth above. The readable storage medium can be a magnetic storage media, such as a magnetic disk (such as a floppy disk) or magnetic tape; optical storage media, such as an optical disk, an optical tape, or a machine readable bar code; solid state electronic storage devices, such as a random access memory (RAM) or a read only memory (ROM); or any other physical device or medium employed to store computer programs.

The present invention is not limited to the particular leasing and/or sales arrangements discussed above. Various other methods for providing photographic goods and services may be employed in accordance with the present invention. Referring to FIG. 12, there is illustrated a schematic diagram of an alternate method and system 900 in accordance with the present invention, like numerals indicating like parts and operations as previously discussed. A consumer or customer desiring to utilize the system 900 would access a service provider 908 via any appropriate communication network using an appropriate input station. Examples of suitable input stations are illustrated in FIG. 12. For example, a personal computer 910, a kiosk 912 at retail location, a cable set top box 914, cellular phone 915, or a hard wired phone 917. With respect to the use of computer 910, communication with photographic service provider 908 is accomplished through the use of an internet service provider 918 which provides communication via the internet 919. The user can input selections utilizing software provided by the service provider 908 or a third party. The software could include a menu of cameras to be selected and a menu of photographic product/service plans to be supplied by photographic product/service provider 908. The service provider 908 could be a photofinishing wholesale lab, a minilab, a retail store, etc. As illustrated the service provider 908 has a server 920 for communication to various input stations. The server 920 is in communication with a computer 922 which includes image data base 924 for storing digital images sent to the service provider 908 and a customer data base 926 for associating the stored digital images with particular customer. The service provider 908 is associated with a fulfillment provider 918 that provides the goods and/or services being requested by the customer through the service provider 908. These goods and services may comprise the purchase and/or lease of any goods and/or services, including but not limited to prints, mugs, digital image storage and remote access, photo CD, reprints, image services, etc. The fulfillment provider 918 may be separate or be incorporated as a part of the service provider 908.

As previously noted digital images and customer orders for goods and/or services can be obtained and communicated to service provider 908 by various means. For example

a digital camera **928** may be used for capturing of digital images which can down loaded to personal computer **910**, phone **917**, or kiosk **912**. The digital images and orders can then be forwarded to access service provider **908** through internet service provider (ISP) **932** and internet **919**.

Alternatively, digital images may be forwarded to service provider **908** from cable box **914** which is communication with a cable head end server **938** of a local cable service provider **939**. The cable box **914** is hook to an associated television and/or monitor **941**. The cable service provider **939** may also have a digital storage device **940** for storing digital images and associated information forwarded from the cable box **914**. Digital images may be inputted into cable box **914** using digital camera **928** and appropriate Universal Serial Bus (USB) port provided on box **914**. A touch pad **936** on box **914** or remote cable box control device may be used to program box **914** for receiving and/or transmitting of images and associated data to and from server **938**. An advantage of using a local cable provider **939** is that transmissions to and from the cable box **914** is on a broadband communication network which allows for the quick transmission of large digital data files such as that associated with digital image files. Additionally use of a cable box avoids the necessity of a customer to have a computer in the house and pay additional communication fees for an ISP and/or extra communication lines. When an image is uploaded to the cable service provider **939** it is preferably done at a high resolution. This allows the cable service provider **939** to be able forward on as a high resolution digital image or as low resolution image, retaining the high resolution image at data base **940**. This is of additional advantage in the situation when the customer forwards the image to another third person, such as a relative, who does not have a computer, but has a cable box **914**. The low resolution image can be forwarded to the third party and the third party can place an customer order as previously discussed with the image service provider **908**. The high resolution image would then be sent to the service provider **908** avoiding the necessity of sending the high resolution to the third party, and thus, making it more efficient image transmission system for all involved. An acknowledgement can be sent to the original customer advising the customer that the third party has placed an order using one of the forwarded images. A confirmation message can also be sent to the third party customer through use of the cable box **914**. The original customer can also place a customer image order with the service provider **908** which is to be forwarded to a designated third party and confirmation of this can be forwarded to the designated third party. The customer image order may comprise, but not limited to print, a product having an image, for example, a mousepad, puzzle, shirt, album page, etc.

At any of the input stations a user can select a camera from a menu of cameras or other available goods or services. In the situation where photographic input station is located at a retail location, the customer could also have the option of trying out several selected cameras to decide which camera the customer would prefer. At the same time, the customer can select a photographic product/service plan from a menu of available plans that is associated with the selected camera. The photographic product/service plan will define the photographic products and/or services that are associated with the selected camera.

The photographic product/service plan would also be set for a monthly or yearly fee in which a predetermined amount of photographic services and/or products, as discussed above, are provided to the user for the designated fee. Once

the user selects the camera and the photographic product/service plan, this information is entered into a customer data base to set up a user product/service account indicative of the selected camera and the selected photographic product/service plan. The data base stores the information with respect the selected camera and the selected photographic product/service plan, and is further adapted to update the user product/service account as services and/or products are provided to the customer. In addition more than one plan may be associated with a single input station. Separate accounts can then be set up with respect to an individual and/or a particular camera or other product. An account ID or product serial number could be used for identification of a particular account.

In the case where the selected camera is a film camera or hybrid digital-film camera, the photographic product/service plan can provide photographic services and/or products such as supplying a selected amount of photographic prints from rolls of film exposed by the selected camera **14a**, automatically supplying additional rolls of unexposed film at a predetermined rate. The predetermined rate may be at a specific cycle rate, for example, five rolls of film per month, a new roll when an exposed roll is received, or upon request. Further, the photographic product/service can include scanning images on the film exposed by the selected camera **928** to create a digital record of the image. As a further option, the photographic product/service plan can include scanning the film exposed by the selected camera and providing a disk or photo CD of the scanned images. As a yet further option, the digital record of the scanned images can be returned to a user or designated recipient electronically via, for example, internet. A further option can involve scanning and storing the images for a predetermined amount of time. Other options available under the photographic product/service plan could include the creation of image products **14a** such as cups, mugs, T-shirts, etc.

In the case where the selected camera is a digital camera, the photographic product/service plan could provide photographic services and/or products in the form of (1) the electronic storage of images captured by the camera for a predetermined amount of time as set in the photographic product/service plan; (2) the electronic forwarding of images captured by the camera to a designated recipient; (3) the provision of prints of images captured by the digital camera; (4) the provision of an image product such as a T-shirt for an image captured by the camera; or (5) a disk having the images captured by the selected camera.

Of course, it is noted that under the system and method of the present invention, the user is not limited to pre-selected services and/or products under a plan. With the system and method of the present invention, a user can create personal customized plans which only includes services and/or products specifically chosen by him/her.

Thus, for a periodic fee such as a monthly or yearly fee, the user would have photographic services and/or products as described above rendered to images digitally captured and/or film exposed by the selected camera. The fulfillment center **918** operationally associated with photographic product/service provider **908** would continually update the created user product/service account as photographic services and/or products are rendered to a user and/or completed.

At the end of the account, subscription or contract, the user may have the option of keeping the selected camera at no cost, purchasing the selected camera at a reduced rate, or exchanging the selected camera for a new camera.

Thus, an advantage of the system and method of the present invention is that it provides for a convenient way for

a consumer to use a high end digital camera at a low front end cost. It further permits the consumer to bundle the use of the selected camera with a variety of customer product/service plans which can be customized in accordance with the consumer's preference.

The invention has been described in detail with particular reference to certain preferred embodiments thereof, but it will be understood that variations and modifications can be effected within the scope of the present invention. The present invention being limited by the claims that follow.

PARTS LIST

10 computer
 12 CPU motherboard
 14 display monitor
 16 keyboard
 18 mouse
 20 hard drive
 22 dial-in modem
 24 color scanner
 30 Internet service provider equipment
 32 modem
 34 computers/routers
 36 channel
 40 product customization center
 42 Internet server
 44 electronic database
 46 billing system
 50 product configuration system
 52 manufacturing customization computer
 54 product firmware database
 58 product label printer
 60 custom label
 70 shipping system
 72 shipping label printer
 74 shipping label
 80 customized imaging device
 300 electronic camera
 302 flash
 303 user controls
 304 control processor and timing generator circuit
 306 clock driver
 308 autofocus and autoexposure detectors
 310 zoom and focus motor drives
 312 zoom lens
 314 image sensor
 316 analog signal processing and analog-to-digital converter circuit
 318 DRAM buffer memory
 320 image processor
 322 host interface
 324 memory card interface
 326 RAM memory
 328 firmware memory
 330 flash memory card
 332 image display
 340 host computer
 342 interface cable
 350 film camera
 352 zoom lens
 354 zoom and focus motors
 356 autofocus and autoexposure detectors
 358 flash
 360 magnetic writer unit
 362 film transport unit
 364 control processor

366 host interface
 367 interface cable
 368 RAM memory
 370 firmware memory
 5 372 user controls
 374 LCD display
 380 APS film
 400 digital printer
 410 media transport mechanism
 10 412 marking apparatus
 420 processor
 424 memory card interface
 426 RAM memory
 428 firmware memory
 15 430 removable memory card
 432 display
 440 host computer
 442 host interface
 500 digital image display device
 20 520 processor
 526 RAM memory
 528 firmware memory
 530 removable memory card
 532 color image display
 25 540 host computer
 542 host interface
 544 modem
 600 one-time use film camera
 610 exterior camera package
 30 612 main front cover section
 614 back cover section
 615 position
 616 taking lens
 618 viewfinder window
 35 620 top section
 622 shutter release button
 624 exposure counter wheel number
 628 viewfinder eyepiece
 630 thumb wheel opening
 40 640 thumb wheel
 700 filmstrip
 700a first image frame
 702 filmstrip leader
 728 perforation
 45 730 film cartridge
 732 hub
 734 film cartridge door
 736 cartridge shell
 738 end plates
 50 750 film package
 752 area
 800 subsystem
 810 magnetic recording subsystem
 820 system controller
 55 822 motor driven roller
 824 idler roller
 826 motor driven roller
 828 idler roller
 832 hub
 60 834 backing support
 836 magnetic read/write head
 840 light source
 842 transparency
 844 shutter
 65 846 imaging lens
 848 exposure gate
 850 perforation sensor

- 860 block
- 862 block
- 864 block
- 866 block
- 868 block
- 870 block
- 872 block
- 874 block
- 876 block
- 878 block
- 880 block
- 882 block
- 884 block
- 886 block
- 888 block
- 908 service provider
- 910 personal computer
- 912 kiosk
- 914 cable set top box
- 915 cellular phone
- 917 phone
- 918 fulfillment provider
- 919 Internet
- 920 server
- 922 computer
- 924 image database
- 926 customer database
- 928 digital camera
- 930 Internet Service Provider (ISP)
- 936 touch pad
- 939 cable service provider
- 940 digital storage device
- 941 TV/monitor

What is claimed is:

1. A method of providing photographic products and/or photographic services, the method comprising the steps of: selecting a camera among a selection of cameras for a predetermined time period at a predetermined fee; selecting a photographic product and/or photographic service plan from a menu of photographic product and/or photographic service plans; associating the selected camera with the selected photographic product and/or photographic service plan and creating a product and/or photographic service plan account indicative thereof; entering said product and/or photographic service plan account into a computer database to maintain a record of photographic products and/or photographic services to be provided with respect to images captured by said selected camera in accordance with the selected photographic product and/or photographic service plan for a predetermined period of time; and automatically accessing said computer database when images are received from said selected camera and providing the associated photographic product or photographic service according to the photographic product and/or photographic service plan associated with the selected camera.

2. A method according to claim 1, wherein said photographic products and/or photographic services comprise providing said selected camera to a user for a predetermined time period at a predetermined fee, and providing film development for a predetermined number of rolls of film exposed by said selected camera during said predetermined time period.

3. A method according to claim 2, wherein said photographic services and/or photographic products further comprise providing a selected amount of photographic prints of said developed film.

4. A method according to claim 2, wherein said photographic products and/or photographic services further comprise scanning the images on said film to provide for a digital record of said images.

5. A method according to claim 4, wherein said digital record is placed on a disk and supplied to a user or designated recipient.

6. A method according to claim 4, wherein said digital record is electronically forwarded to a user or designated recipient.

7. A method according to claim 4, wherein said photographic products and/or photographic services further comprise electronically storing said digital record for a predetermined amount of time.

8. A method according to claim 1, wherein said photographic products and/or photographic services comprise electronically storing images captured by said selected camera for a predetermined period of time.

9. A method according to claim 1, wherein said photographic products and/or photographic services comprise providing a predetermined number of prints of images captured by said selected camera.

10. A method according to claim 1, wherein said selected camera is a film camera.

11. A method according to claim 1, wherein said selected camera is a digital camera.

12. A method according to claim 1, wherein said selected camera is a hybrid digital/film camera.

13. A method according to claim 1, wherein said photographic products and/or photographic services comprise providing an image product associated with an image captured by said selected camera.

14. A method according to claim 1, comprising the further step of updating the product and/or photographic service plan account in the computer database as said photographic products and/or photographic services, in accordance with the selected photographic product and/or photographic service plan, are provided to a user to reflect photographic products and/or photographic services rendered to the user.

15. A method of providing photographic products and/or photographic services to a consumer, the method comprising the steps of: selecting a camera from a plurality of cameras for a predetermined time period at a predetermined fee and selecting a photographic product and/or photographic service by a customer from a menu of photographic products and/or services which are to be associated with said selected camera for a predetermined time period, wherein said photographic product and/or photographic service is provided with respect to images captured by said selected camera; maintaining an account on a computer database of said selected photographic products and/or photographic service associated with said selected camera; and automatically accessing said account on said computer database with respect to images received from said selected camera and providing said good and or service associated with said selected camera according to the photographic product and/or photographic service plan associated with the selected camera.

16. A method according to claim 15, wherein said photographic product and/or photographic service comprises creating a predetermined number of prints from said images.

17. A method according to claim 15, wherein said photographic product and/or photographic service comprises placing said images on a disk and forwarding said disk to the customer.

18. A method of providing photographic products and/or photographic services, the method comprising the steps of: selecting a camera from a plurality of cameras for a predetermined time period at a predetermined fee and selecting a photographic product and/or photographic service from a menu of photographic products and/or photographic services by a customer which are to be associated with said camera for a predetermined time period, wherein said photographic products and/or photographic services are provided to film exposed by said selected camera;

maintaining a record of photographic products and/or photographic services of said photographic services and/or photographic products selected by said customer on a computer database to be provided to said customer; and

automatically accessing said computer database for determining said photograph product or service to be provided with respect to received images captured by said selected camera according to the photographic product and/or photographic service plan associated with the selected camera.

19. A method according to claim 18, wherein said photographic products and/or photographic services comprise developing said exposed film and providing a predetermined number of prints of images on said film.

20. A method according to claim 18, wherein said photographic products and/or photographic services comprise scanning said film to create a digital record of images on said film.

21. A method according to claim 20, wherein said photographic products and/or photographic services further comprise placing said digital record on a disk and forwarding said disk to the customer.

22. A method according to claim 20, wherein said photographic products and/or photographic services further comprise electronically storing said digital record for a predetermined period of time.

23. A method according to claim 20, wherein said photographic products and/or photographic services further comprise electronically sending said digital record of said images to the user.

24. A system for providing photographic products and/or photographic services, the system comprising:

a photographic product and/or photographic service input station into which information with respect to a selected camera for a predetermined time period at a predetermined fee and a selected photographic product and/or photographic service plan which is to be associated with the selected camera for a predetermined period of time is input, said photographic product and/or photographic service input station creating a product and/or photographic service account indicative of the selected camera and the selected photographic product and/or photographic service plan; and

a computer database unit operationally associated with the photographic product and/or photographic service input station which receives and stores the information with respect to the selected camera and the selected photographic product and/or photographic service plan, said computer database unit automatically updating said product and/or photographic service account as photographic product and/or photographic services in accordance with said selected photographic product and/or photographic service plan are requested and completed.

25. A system according to claim 24, wherein said computer database is operationally associated with at least one photographic product and/or photographic service provider, and said selected photographic product/photographic service plan comprises providing photographic products and/or photographic services to film exposed by said selected camera through said at least one photographic product and/or photographic service provider in accordance with the photographic product and/or photographic service plan for a predetermined time period.

26. A system according to claim 25, wherein said photographic products and/or photographic services comprise providing film developing for film exposed by said selected camera for said predetermined time period.

27. A system according to claim 26, wherein said photographic products and/or photographic services comprise providing prints of said developed film.

28. A system according to claim 25, wherein said photographic products and/or photographic services comprise scanning images on said film to provide a digital record of the images.

29. A system according to claim 28, wherein said digital record is placed on a disk and returned to a designated recipient.

30. A system according to claim 28, wherein said digital record is electronically forwarded to a designated recipient.

31. A system according to claim 28, wherein said photographic products and/or photographic services comprise storing said digital record for a predetermined amount of time.

32. system according to claim 24, wherein said photographic products and/or photographic services comprise electronically storing images captured by said selected camera for a predetermined period of time.

33. A system according to claim 24, wherein said photographic products and/or photographic services comprise providing a predetermined number of prints of images captured by said selected camera.

34. A system according to claim 24, wherein said photographic products and/or photographic services comprise providing an image product associated with an image captured by said selected camera.

35. A system according to claim 24, wherein said selected camera is one of a film, digital or hybrid film/digital camera.