

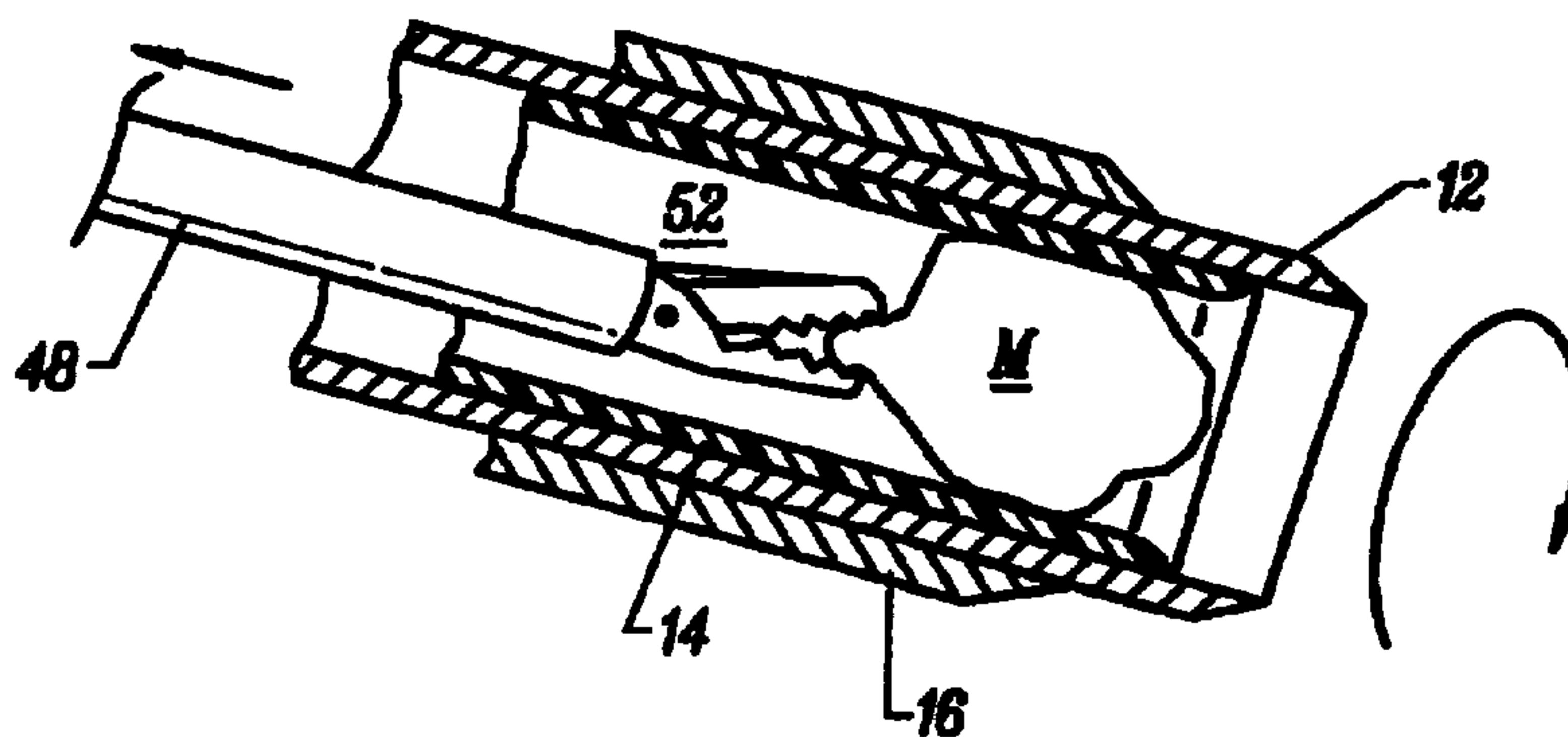

(72) SAVAGE, GEORGE M., US
(72) CHRISTIAN, JEFFREY J., US
(72) DILLOW, DAVID CURTIS, US
(71) ETHICON, INC., US
(51) Int.Cl.⁷ A61B 17/14
(30) 1997/08/05 (08/906,358) US
(54) **APPAREIL DE MORCELLEMENT LAPAROSCOPIQUE
JETABLE**
(54) **DISPOSABLE LAPAROSCOPIC MORCELLATOR**



(57) Un appareil de morcellement (10) destiné à retirer des masses importantes de tissus pendant des interventions laparoscopiques comprend un tube intérieur (14) non rotatif et fixe axialement disposé à l'intérieur d'un élément coupant rotatif (12). L'élément coupant (12) est souvent disposé dans l'espace annulaire entre le tube intérieur (14) et un tube extérieur (16). Un instrument de préhension laparoscopique (42) est inséré à travers la lumière et il tire les tissus de manière proximale à travers l'appareil de morcellement (10). A mesure que l'élément coupant (12) coupe le tissu, le tissu est tiré à l'intérieur de la lumière fixe du tube intérieur (14). Ceci empêche les éléments coupants (12) de vriller le tissu coupé, empêchant ainsi toute dégradation des commandes dont dispose le chirurgien. Une nouvelle soupape (28) est disposée pour empêcher la perte de gaz d'insufflation lorsqu'aucun instrument ne traverse la lumière. Le tube intérieur (14) peut être déplacé distalement afin de protéger les tissus, et/ou pour empêcher que d'autres instruments chirurgicaux ne viennent en contact accidentel avec le tranchant de l'élément coupant (12).

(57) A morcellator (10) for removing large masses of tissues during laparoscopic procedures includes a rotationally fixed, axially movable inner tube (14) disposed within a rotating cutting member (12). The cutting member (12) is often disposed in the annular space between the inner tube (14), and an outer tube (16). A laparoscopic grasping instrument (42) is inserted through the lumen, and draws the tissue proximally through the morcellator (10). As the cutting member (12) severs tissue, the tissue is drawn into the fixed lumen of the inner tube (14). This prevents the cutting members (12) from twisting the severed tissue, thereby preventing any degradation of the surgeon's control. A novel valve (28) is provided to prevent loss of insufflation gas when no instrument traverses the lumen. The inner tube (14) can be translated distally to protect tissue, and/or other surgical implements against inadvertent contact with the cutting edge of the cutting member (12).

PCTWORLD INTELLECTUAL PROPERTY ORGANIZATION
International Bureau

INTERNATIONAL APPLICATION PUBLISHED UNDER THE PATENT COOPERATION TREATY (PCT)

(51) International Patent Classification⁶ :

A61B 17/14

A1

(11) International Publication Number:

WO 99/07295

(43) International Publication Date:

18 February 1999 (18.02.99)

(21) International Application Number: PCT/US98/16108

(22) International Filing Date: 31 July 1998 (31.07.98)

(30) Priority Data:

08/906,358

5 August 1997 (05.08.97)

US

(71) Applicant: FEMRX, INC. [US/US]; 1221 Innsbruck Drive, Sunnyvale, CA 94089 (US).

(72) Inventors: SAVAGE, George, M.; 1180 Westridge Drive, Portola Valley, CA 94028 (US). CHRISTIAN, Jeffrey, J.; 608 Curie Drive, San Jose, CA 95123 (US). DILLOW, David, Curtis; 22851 Longdown Road, Cupertino, CA 95014 (US).

(74) Agents: HESLIN, James, M. et al.; Townsend and Townsend and Crew LLP, 8th floor, Two Embarcadero Center, San Francisco, CA 94111-3834 (US).

(81) Designated States: AU, CA, JP, European patent (AT, BE, CH, CY, DE, DK, ES, FI, FR, GB, GR, IE, IT, LU, MC, NL, PT, SE).

Published*With international search report.*

(54) Title: DISPOSABLE LAPAROSCOPIC MORCELLATOR

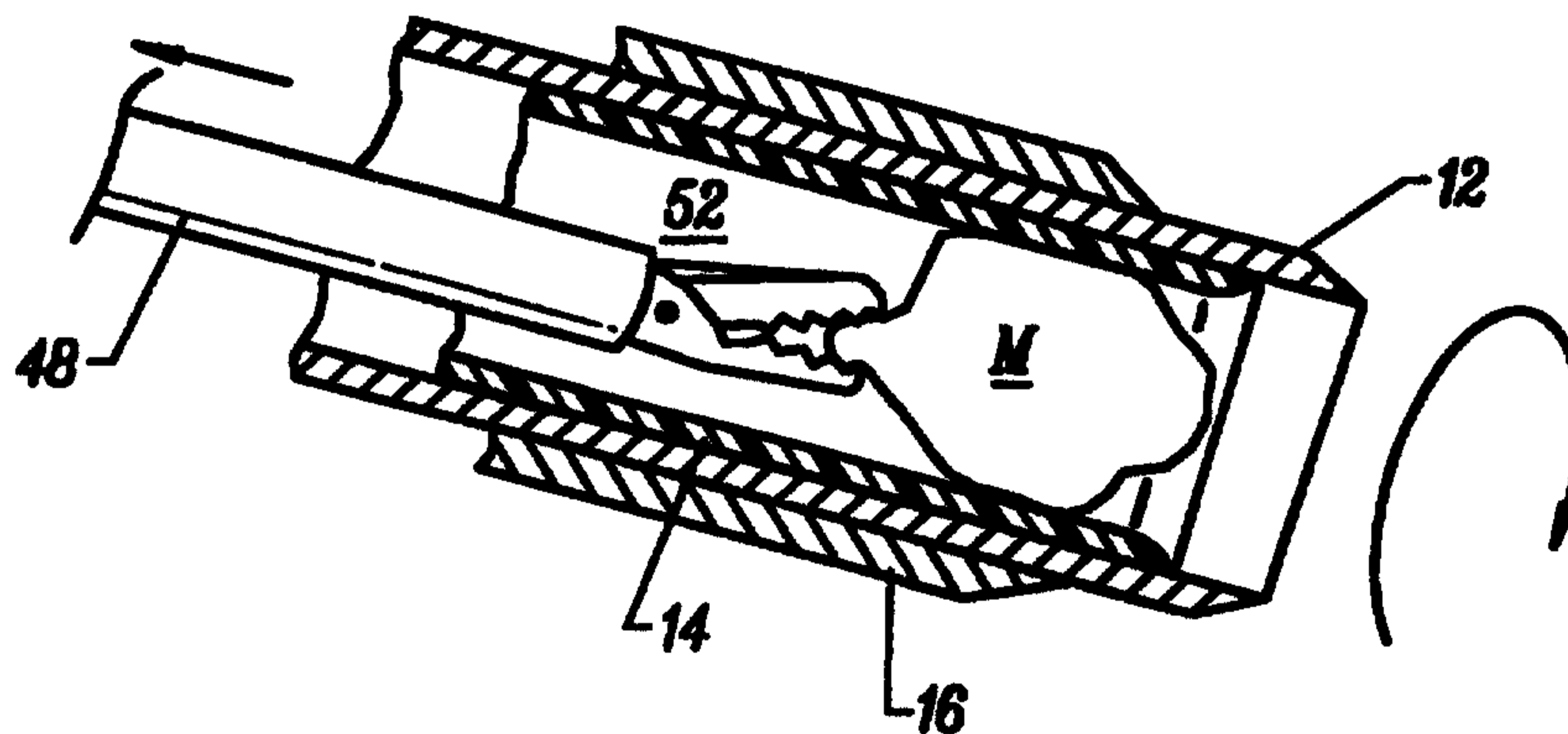

(57) Abstract

A morcellator (10) for removing large masses of tissues during laparoscopic procedures includes a rotationally fixed, axially movable inner tube (14) disposed within a rotating cutting member (12). The cutting member (12) is often disposed in the annular space between the inner tube (14), and an outer tube (16). A laparoscopic grasping instrument (42) is inserted through the lumen, and draws the tissue proximally through the morcellator (10). As the cutting member (12) severs tissue, the tissue is drawn into the fixed lumen of the inner tube (14). This prevents the cutting members (12) from twisting the severed tissue, thereby preventing any degradation of the surgeon's control. A novel valve (28) is provided to prevent loss of insufflation gas when no instrument traverses the lumen. The inner tube (14) can be translated distally to protect tissue, and/or other surgical implements against inadvertent contact with the cutting edge of the cutting member (12).

DISPOSABLE LAPAROSCOPIC MORCELLATOR

5

CROSS-REFERENCE TO RELATED APPLICATION

This application is related to application Serial No. _____ (Attorney Docket No. 16944-002800), assigned to the present assignee and filed concurrently herewith, the full disclosure of which is incorporated herein by reference.

10

BACKGROUND OF THE INVENTION

15 1. Field of the Invention

The present invention is generally related to surgical devices and methods, and in particular, provides a morcellator having a rotating cutting member for severing and removing tissues.

20

Minimally invasive surgical procedures have gained wide acceptance in the areas of general and gynecological surgery. Minimally invasive techniques are now being developed for therapies of the heart, lung, kidney, and the like. Generally, these procedures make use of one or more small incisions (or other openings) to access internal tissues, often through a cannula, trocar, or other access device. Gas insufflation or fluid distension may be used to enhance the available space within the internal surgical site, and the therapy is often directed with reference to an image provided by an endoscope, a microscope, or using a remote imaging modality such as fluoroscopy, ultrasound, or the like. Generally, minimally invasive surgical procedures minimize patient trauma and speed recovery over traditional open surgical procedures.

25

30

35

Unfortunately, many surgical techniques are difficult to accomplish through laparoscopic cannulas or other minimally invasive access devices. It is sometimes desirable to remove relatively large masses of tissue, for example, to

remove a kidney, a partial lung resection, or the like. Removing such large tissue masses laparoscopically through a small access lumen is fairly difficult and time consuming.

Specialized devices have recently been proposed to sever large tissue masses into segments, which are more easily removed. These devices generally include a rotating tube having a sharpened distal end which extends through a fixed outer tube. This sharpened end is inserted into the patient through a cannula, or directly through an incision. The surgeon inserts a grasping device (such as endoscopic forceps or a laparoscopic grasper) through the rotating tube. Grasping the large mass of tissue to be removed, the surgeon pulls the tissue up into the tube, so that the rotating edge severs the grasped portion from the large mass. The size of the severed tissue is generally limited by the outline of the rotating edge, so that the surgeon can continue to pull the severed tissue out of the patient through the rotating tube. By repeating the grasping and severing procedure, surgeons can remove relatively large masses of tissue quite quickly. As the large tissue mass is removed in small, individually grasped morcels, these devices are often referred to as "morcellators".

Although rotating tube morcellators represent a significant advancement in minimally invasive surgical procedures for removing large tissue masses, these known devices still have several significant drawbacks. First, these known devices are relatively large, heavy, and expensive. Sterilizing these devices is fairly time consuming, and sliding motion between the tubes and dulling of the cutting edge limits their useful life. More importantly, work in connection with the present invention has found that friction between the rotating tube and the severed tissue morcel often causes the tissue to turn or twist the grasping instrument in the surgeon's hand. This can significantly lessen the surgeon's ability to control his or her instruments, and can potentially be dangerous for both the patient and the surgeon.

In light of the above, it would be desirable to provide improved methods and devices for removing tissues from internal surgical sites. It would be particularly desirable if these improved methods and devices were adaptable for use with known laparoscopic and other minimally invasive surgical techniques. It would further be desirable if such improved methods and devices enhanced the surgeon's control over the tissue removal procedure, thereby avoiding injury to both the patient and the attending physician, but at a lower cost than known morcellator techniques.

2. Description of the Background Art

An endoscopic morcellator is described in U.S. Patent No. 5,562,694. A mechanical morcellator is described in U.S. Patent No. 5,520,634. U.S. Patent No. 5,439,474 describes a morcellator system, while a related device is described in U.S. Patent No. 5,443,472. A method and system for removal of tissue from within a body cavity are described in U.S. Patent No. 5,336,237. A laparoscopic organ retrieval apparatus and procedure is described in U.S. Patent No. 5,215,521. U.S. Patent No. 5,176,695 is also relevant.

SUMMARY OF THE INVENTION

The present invention provides a morcellator which is particularly advantageous for removing large masses of tissues during laparoscopic and other minimally invasive surgical procedures. In general, the laparoscopic morcellator of the present invention includes a fixed inner tube disposed within a rotating cutting member. The cutting member is often disposed in the annular space between the inner tube and an outer tube, the inner and outer tubes and the cutting member presenting a substantially rigid tubular structure. A laparoscopic grasping instrument can be inserted through the lumen and draw tissue proximally into the rotating cutting member. As a distal end of the cutting member severs tissue, the severed tissue is drawn into the fixed lumen of the inner

tube. This prevents the cutting member from twisting the severed tissue, thereby preventing any degradation of the surgeon's control. A novel valve can prevent loss of insufflation gas when no instrument traverses the lumen. The valve is adapted for passing surgical implements distally, and also for passing large morcels of severed tissue proximally. A low cost, disposable, and highly effective morcellator structure can be provided by powering the cutting member with a standard flex drive cable coupler.

In a first aspect, the present invention provides a device for surgically removing tissue from a patient body. The device comprises an outer tube having a proximal end and a distal end. An inner tube is disposed within the outer tube, with the inner and outer tubes defining an annular space therebetween. A cutting member rotates within this annular space relative to both the inner and outer tubes. The cutting member has an exposed cutting surface near the distal end.

Generally, the cutting member comprises a tube having a sharpened annular cutting edge extending distally of both the inner and outer tubes. A lumen of the inner tube admits severed tissue fragments at the distal end, and passes the severed tissues proximally out the proximal end. This lumen is generally sized to accommodate a tissue grasping device which can be actuated from proximally of the tubes to grasp tissues targeted for severing.

In another aspect, the present invention provides a system for surgically removing tissue from a patient body. The system comprises an outer tube having a proximal end and a distal end. An inner tube is disposed within the outer tube, and an annular space is defined between the inner and outer tubes. The inner tube has a lumen, and a grasping device is extendable through this lumen and actuatable from proximally of the tubes to grasp target tissues distally of the tubes. A cutting member rotates within the annular space relative to the inner and outer tubes to sever the grasped tissues. The cutting member has an exposed cutting surface near the distal end for severing the target tissues from an internal body site.

In another aspect, the present invention provides a method for severing target tissues from an internal body site. The method comprises grasping the target tissue and severing the grasped tissue with a rotating tubular cutting member. The grasped tissue is then drawn from the internal body site through a lumen within the tubular cutting member. The cutting member rotates relative to this lumen.

BRIEF DESCRIPTION OF THE DRAWINGS

Fig. 1 is a perspective view of a laparoscopic morcellator according to the principles of the present invention, in which a portion of the housing is removed to show a mechanism for rotating a cutting tube between fixed inner and outer tubes, and in which a portion of the inner tube has been removed to show a valve within a lumen of the inner tube.

Fig. 2 is a side view of a laparoscopic tissue removal system, including the laparoscopic morcellator of Fig. 1 and an endoscopic grasper which has been inserted through the lumen of the inner tube.

Fig. 3 illustrates the use of the laparoscopic morcellator of Fig. 1 for laparoscopic removal of a uterine myoma.

Figs. 4A-C illustrate how the fixed internal tube of the laparoscopic morcellator of Fig. 1 prevents rotation or twisting of the grasped tissue morcel while the morcel is being withdrawn proximally through the rotating cutting tube.

Figs. 5-5C illustrate a valve for use in the laparoscopic morcellator of Fig. 1, in which a first pair of segments taper inwardly and distally to prevent leakage of insufflation gas when no instrument traverses the valve, and in which a second pair of segments taper outwardly and distally so that the valve easily passes tissue fragments drawn proximally through the morcellator.

Fig. 6A illustrates how insufflation pressure is transmitted through openings in the distal segments of the

valve of Fig. 5 to enhance sealing when no surgical instrument traverses the valve.

Fig. 6B illustrates how the distal segments of the valve of Fig. 5 facilitate proximal passage of a tissue morcel without everting the proximal valve segments.

Fig. 7 is a perspective view of an alternative laparoscopic morcellator having many of the same structures of the laparoscopic morcellator of Fig. 1, and in which the inner tube can slide axially within the cutting member to prevent inadvertent contact between the cutting edge and tissues, laparoscopic instruments, and the like.

Figs. 7A-7C illustrate an actuation mechanism and support structure for the axially sliding inner tube of Fig. 7, which allow the inner tube to act as a blade guard, according to the principles of the present invention.

DETAILED DESCRIPTION OF THE SPECIFIC EMBODIMENTS

The structures and methods of the present invention will significantly facilitate the severing and removal of tissues from internal surgical sites during both minimally invasive and traditional open surgical procedures. These methods and structures are particularly well adapted, however, for laparoscopic procedures requiring removal of significant masses of tissues, such as for removal of a kidney, resection of a lung portion, and for removing other target tissues of the abdomen and/or thorax. Access and optical visualization of such tissue removal procedures is generally facilitated by pneumo-peritoneum (gas insufflation), and by positioning of an endoscope, laparoscope, or the like, within the distended body cavity. The structures and methods of the present invention will find their most immediate application during laparoscopic myomectomy (sometimes called a celiomyomectomy), often using an abdominal approach.

Referring now to Fig. 1, a disposable laparoscopic morcellator 10 includes a rotating tubular cutting member 12 disposed in the annular space between an inner tube 14 and an outer tube 16. A sharpened annular cutting edge 18 extends

distally of a distal end 20 of the outer tube, while a proximal housing 22 is affixed to the proximal end 24 of the outer tube. The outer tube thereby prevents injury or twisting of morcellator 10 against the cannula surrounding the outer tube, against the skin, or against the tissue tract leading to the internal surgical site. Hence, the outer tube allows the physician to safely manipulate laparoscopic morcellator 10 when the tubular cutting member rotates.

Inner tube 14 is also affixed to housing 22. A proximal port 26 in the housing provides access to the lumen of the inner tube through a valve 28. Inner tube 14 is affixed to housing 22 proximally of a cutting tube drive mechanism 30, and extends distally into (and is supported by) the surrounding rotating cutting tube 12.

Drive mechanism 30 here comprises a pair of angled bevelled gears powered by a standard flex cable 32 through a flex cable coupler 34. The use of an external drive motor minimizes the weight and cost of morcellator 10, thereby making it feasible to provide a disposable morcellator structure. This avoids any need to use surgically sterilizable materials or a sharpenable cutting edge 18, and avoids long term wear between the tubes. Hence, the tubes may comprise inexpensive tube materials in simple sliding contact.

Inner tube 14, rotating cutting member 12, and outer tube 16 define a substantially rigid tubular structure in which the inner lumen of the inner tube is generally between about 0.25 and 0.9 inches in diameter, while the outer surface of outer tube 16 will preferably have a diameter of between about 0.3 and 1.0 inches. Rotating cutting member 12 will typically be formed of stainless steel, but may alternatively comprise other materials. Cutting edge 18 may be smooth or serrated. Inner tube 14 and outer tube 16 may comprise polymer or metallic structures, ideally being formed of fiber reinforced polymer. The tubes and cutting member will typically extend from housing 22 by a distance in the range between about 7.0 inches and 12.0 inches. Low friction coatings or lubrication may optionally be provided between the

fixed tubes and cutting member 12, with friction ideally being limited by silicone lubricant.

Proximal housing 22 may comprise a metallic or polymeric structure, ideally being formed of polycarbonate. The beveled gears of drive mechanism 30 are supported by nylon bearings. The drive gear is coupled to flexible drive shaft 32 by coupler 34, while the driven gear is affixed to cutting member 12. Once again, the drive gears may comprise metallic or polymeric materials, ideally being formed of nylon. Such gears are commercially available from Winzeler of Chicago, Illinois.

Referring now to Fig. 2, a tissue removal system 40 generally includes morcellator 10 and a surgical instrument such as a laparoscopic grasper 42, laparoscopic forceps, or the like. Grasper 42 includes jaws 44 coupled to handle 46 by a shaft 48 so that actuation of the handle articulates the jaws for grasping tissue.

Jaws 44 are insertable through proximal port 26 and valve 28 into the lumen of the inner tube, and shaft 48 is generally longer than morcellator 10 so that the jaws can grasp tissues distally of cutting member 12. To minimize the loss of insufflation gas, the lumen of the inner tube may fittingly receive shaft 48. When grasper 42 is removed from morcellator 10, valve 28 substantially seals the lumen. Advantageously, the lumen of the inner tube does not rotate with the cutting member, so that contact between grasper 42 and the surrounding lumen will not twist handle 46 in the hands of the physician.

The use of tissue removal system 40 can be understood with reference to Figs. 3-4C. As illustrated in Fig. 3, a uterus U of a patient body B is viewed using an endoscope 50, typically while the peritoneal cavity is distended under gas insufflation. Optical visualization may generally be provided using any of a variety of endoscopic structures, including telescopic and fiber optic laparoscopes, hysteroscopes, thoracoscopes, bronchoscopes, or the like, as appropriate for the particular tissue removal procedure. Alternatively, optical imaging capabilities may be

incorporated into morcellator 10 or the associated surgical implement. Distension for some procedures may be provided using a clear liquid (such as sorbitol mannitol, saline, and the like), particularly for removal of intrauterine tissues.

5 In some embodiments, the tissue removal procedure may be directed fluoroscopically, ultrasonically, under magnetic resonance imaging, or with some other remote imaging modality, so that no distension need be provided.

10 Morcellator 10 is inserted through an incision I to the internal surgical site. Cutting member 12 will typically not be rotating during insertion to minimize injury to tissues. An obturator may be inserted through the lumen of the inner tube and extend distally of morcellator 10 to help minimize trauma during insertion. Alternatively, the
15 morcellator may be inserted through a cannula or other access device.

Grasper 42 is inserted into and through the lumen of morcellator 10, and is actuated by the physician to grasp myoma M targeted for removal. While myoma M is here shown as
20 a relatively small protruding tissue structure, it should be understood that the method and system of the present invention are also well adapted for removing large masses of tissue by repeatedly grasping and severing target tissue portions.

As can be best understood with reference to Figs. 4A-C, morcellator 10 is advanced distally and grasper 42 is withdrawn proximally so that myoma M is severed from uterus U by cutting edge 18 of rotating member 12. As myoma M is severed from the adjacent tissue, it is drawn into a lumen 52 of inner member 14, which does not rotate with rotating member
30 12. This avoids twisting of grasper 42 as the severed tissue is withdrawn proximally through the morcellator. Additionally, any contact between shaft 48 of grasper 42 and the surrounding lumen 52 will not deflect jaws 44 prior to severing of the tissue, thereby decreasing the potential for
35 inadvertent injury to the adjacent tissue structures. Twisting of partially severed tissues is also minimized, so that cutting edge 18 can cleanly sever the grasped morcel from adjacent tissues with a minimum of trauma.

A particularly advantageous elastomeric sealing member 60 for valve 14 is illustrated in Figs. 5-5C. Sealing member 60 generally comprises a tubular structure having an inner surface 62 and an outer surface 64. Sealing member 60 has a proximal end 66 and a distal end 68, and has an annulus 70 at the proximal end which sealingly engages the lumen of inner tube 14. It should be understood that this lumen may optionally be defined by housing 22 at the proximal end of morcellator 10 (see Fig. 1).

A first pair of segments 72 extend distally from annulus 70, and are angled inward, engaging each other along a slit 74. Taken alone, first segments 72 operate somewhat like a standard "duck-bill" valve, easily passing surgical instruments inserted distally through the valve. Slit 74 provides a gas tight seal when no instrument traverses the valve, and when a pressure on outer surface 64 of segments 72 is greater than a pressure on the inner surface 62 of these first segments.

Extending distally from first segment 72 are a pair of second segments 76. Second segments 76 angle distally and outwardly from slit 74 to a distal annulus 78. Each second segment has an opening 80 which allows gas pressure to pass through the second segments from distally of slit 74 to the outer surface 64 of first segment 72. In other words, an intermediate volume 82 (bordered by the adjacent first and second segments and by the surrounding lumen) is in fluid communication with the lumen of the valve distally of slit 74. Hence, when the pressure distally of the slit is higher than the proximal pressure, the first pair of segments will be pushed against each other by this pressure differential. This enhanced sealing is schematically illustrated in Fig. 6A, and is particularly advantageous for use with gas insufflation pressure P. Alternatively, elastomeric member 60 may find applications for maintaining a seal against pressurized liquid distension media, for maintaining hemostasis, and the like.

The ability of valve 28 having elastomeric member 60 to pass objects both proximally and distally can be understood with reference to Figs. 6A and B. As with known duck-bill

valves, segments 72 may be easily deformed to pass a surgical implement distally through slit 74. However, withdrawing a surgical instrument (such as grasper 42) proximally from known duck-bill valves often causes the valve to evert, so that at least a portion of the sealing segments are angled proximally rather than distally. Once the sealing segments of known duck-bill valves angle proximally, pressure P begins to push the slit open, rather than closed. Additionally, withdrawing enlarged structures (such as grasper 48 holding severed myoma M) proximally through known duck-bill valves can be difficult, as the angled valve segments tend to catch on any bulges. This is particularly problematic when withdrawing several individually severed tissue morcels, as the morcels (or portions thereof) may be pulled free from grasping jaws 48 to block the morcellator lumen.

Advantageously, second segments 76 of elastomeric body 60 provide a smooth transition between the distal lumen and slit 74. Second segments 76 also help support slit 74, preventing first segments 76 from everting as surgical implements and enlarged distal bodies are withdrawn proximally through the valve. In other words, the first and second segments provide a substantially contiguous lumen when elastomeric member 60 is deformed to open slit 74. This significantly improves the ability of the valve to seal after structures are withdrawn proximally, thereby enhancing the ability of the valve to maintain pneumo-peritoneum during a laparoscopic myomectomy.

Elastomeric member 60 may be formed of any suitable elastomeric material, such as rubber, latex, and the like, ideally comprising silicone. While first and second segments 72, 76 are here shown as substantially planar structures, they may alternatively be formed with some curvature. Similarly, while slit 74 here extends straight across the valve, it may alternatively be curved, Y-shaped, X-shaped, or the like, by changing the number and configuration of the first and second segments. The segments will generally be compliant enough to allow an instrument to pass through the valve, and sufficiently resilient to return to their original shape once

the instrument is removed. The valve will generally be capable of passing any instrument having a size up to the inside diameter of the morcellator inner lumen. Typically, such instruments will have a size in the range from about 5.0 mm to about 10 mm in diameter.

Referring now to Fig. 7, an alternative laparoscopic morcellator 90 includes many of the same structural elements described above regarding laparoscopic morcellator 10 of Fig. 1. However, alternative morcellator 90 has a housing 92 which supports a guard actuator 94. As can be understood with reference to Fig. 7A, inner tube 14 is translatably supported by housing 92, so that sliding guard actuator 94 proximally retracts inner tube 14 relative to both outer tube 16 and rotating cutting tube 12. While inner tube 14 is in this proximal position, the distal end of the cutting tube extends distally beyond the inner and outer tubes 14, 16, as illustrated in Fig. 7, and as described above.

However, by sliding guard actuator 94 distally relative to housing 92, inner tube 14 is translated axially, as illustrated in Fig. 7B. With inner tube 14 in this distal position, the distal end of inner tube 14 extends distally of the sharpened cutting edge 18 of rotating member 12, as illustrated in Fig. 7C. Hence, inner tube 14 acts as a blade guard which protects the blade from inadvertent contact with other surgical instruments, and which also prevents inadvertent cutting of tissues during positioning and movement of the laparoscopic morcellator. As can be understood with reference to Figs. 7A and 7B, inner tube 14 is rotationally fixed to housing 92 using pins 96. Advantageously, guard actuator 94 can be advanced distally to protect the cutting edge and surrounding tissues during insertion of the laparoscopic morcellator, during removal of the system after the laparoscopic procedure is finished, and intermittently between insertion and removal of the morcellator as desired by the surgeon.

While the exemplary embodiments of the present invention have been described in considerable detail, by way of illustration and for clarity of understanding, a number of

modifications, adaptations, and changes will be obvious to those of skill in the art. Therefore, the scope of the present invention is limited solely by the appended claims.

WHAT IS CLAIMED IS:

1 1. A device for surgically removing tissue from a
2 patient body, the device comprising:
3 an outer tube having a proximal end and a distal
4 end;
5 an inner tube disposed within the outer tube, the
6 inner and outer tubes defining an annular space therebetween;
7 and
8 a cutting member which rotates within the annular
9 space relative to the inner and outer tubes, the cutting
10 member having an exposed cutting surface near the distal end.

1 2. A device as claimed in claim 1, wherein the
2 cutting member comprises a tube and the cutting surface
3 comprises an annulus which extends distally of the inner and
4 outer tubes.

1 3. A device as claimed in claim 2, wherein the
2 inner tube defines a lumen, and wherein the lumen is open
3 adjacent the distal end to admit tissue fragments severed from
4 a patient body by the cutting member.

1 4. A device as claimed in claim 3, and wherein the
2 lumen is accessible from proximally of the outer tube for
3 removing the tissue fragments.

1 5. A device as claimed in claim 3, further
2 comprising a valve which seals the inner lumen and which
3 passes tissue fragments proximally.

1 6. A device as claimed in claim 3, wherein the
2 lumen is sized to admit a tissue grasping device which extends
3 through the tubes distally of the cutter, the grasping device
4 being actuatable from proximally of the tubes to grasp tissues
5 targeted for severing.

1 7. A device as claimed in claim 1, further
2 comprising a proximal housing affixed to the inner and outer
3 tubes.

1 8. A device as claimed in claim 7, further
2 comprising a mechanism within the housing for rotating the
3 cutting member, wherein the rotating mechanism comprises a
4 coupler for an external drive motor, the device being
5 disposable.

1 9. A system for surgically removing tissue from a
2 patient body, the system comprising:
3 an outer tube having a proximal end and a distal
4 end;
5 an inner tube disposed within the outer tube, the
6 inner and outer tubes defining an annular space therebetween,
7 the inner tube having a lumen;
8 a grasping device extendable through the lumen and
9 actuatable from proximally of the tubes to grasp target
10 tissues distally of the tubes;
11 a cutting member which rotates within the annular
12 space relative to the inner and outer tubes to sever the
13 grasped tissues, the cutting member having an exposed cutting
14 surface near the distal end for severing the target tissues
15 from an internal body site.

1 10. A system as claimed in claim 9, wherein the
2 inner and outer tubes are affixed to a proximal housing,
3 wherein the housing contains a mechanism for rotating the
4 cutting member, the tubes and cutting member defining a
5 substantially rigid tubular structure.

1 11. A system as claimed in claim 10, further
2 comprising a valve adjacent the proximal end of the lumen for
3 sealing the lumen when the grasping mechanism is withdrawn
4 from the lumen, the valve adapted to pass the grasping
5 mechanism distally and to pass the grasping mechanism and the
6 severed target tissue proximally.

1 12. A system as claimed in claim 9, wherein the
2 inner tube is translatably mounted to the outer tube to
3 prevent inadvertent contact with the cutting edge.

1 13. A method for severing target tissue from an
2 internal body site, the method comprising;
3 grasping the target tissue;
4 severing the grasped target tissue with a rotating
5 tubular cutting member;
6 drawing the grasped tissue from the internal body
7 site through a lumen within the tubular cutting member,
8 wherein the cutting member rotates relative to the lumen.

1/7

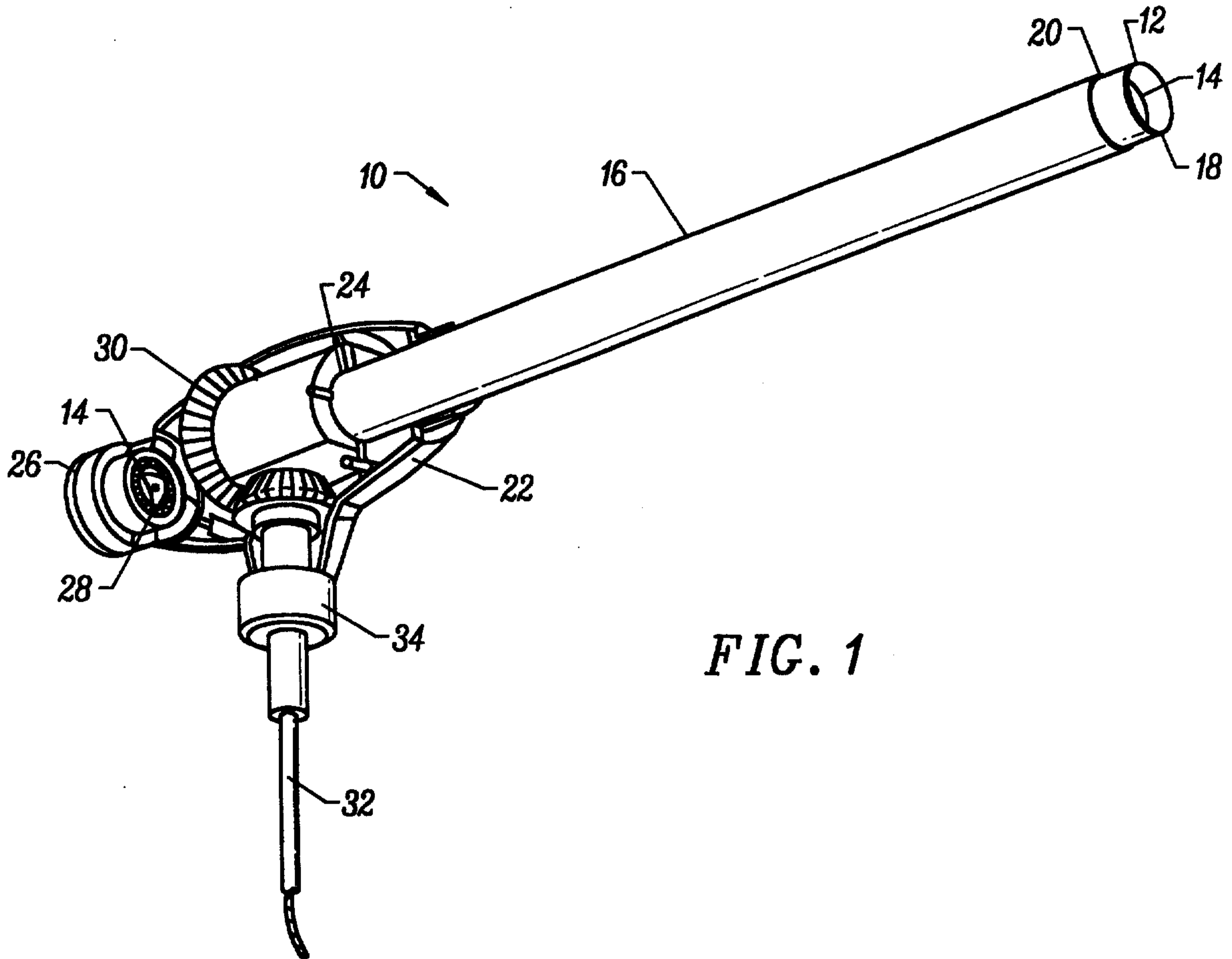

FIG. 1

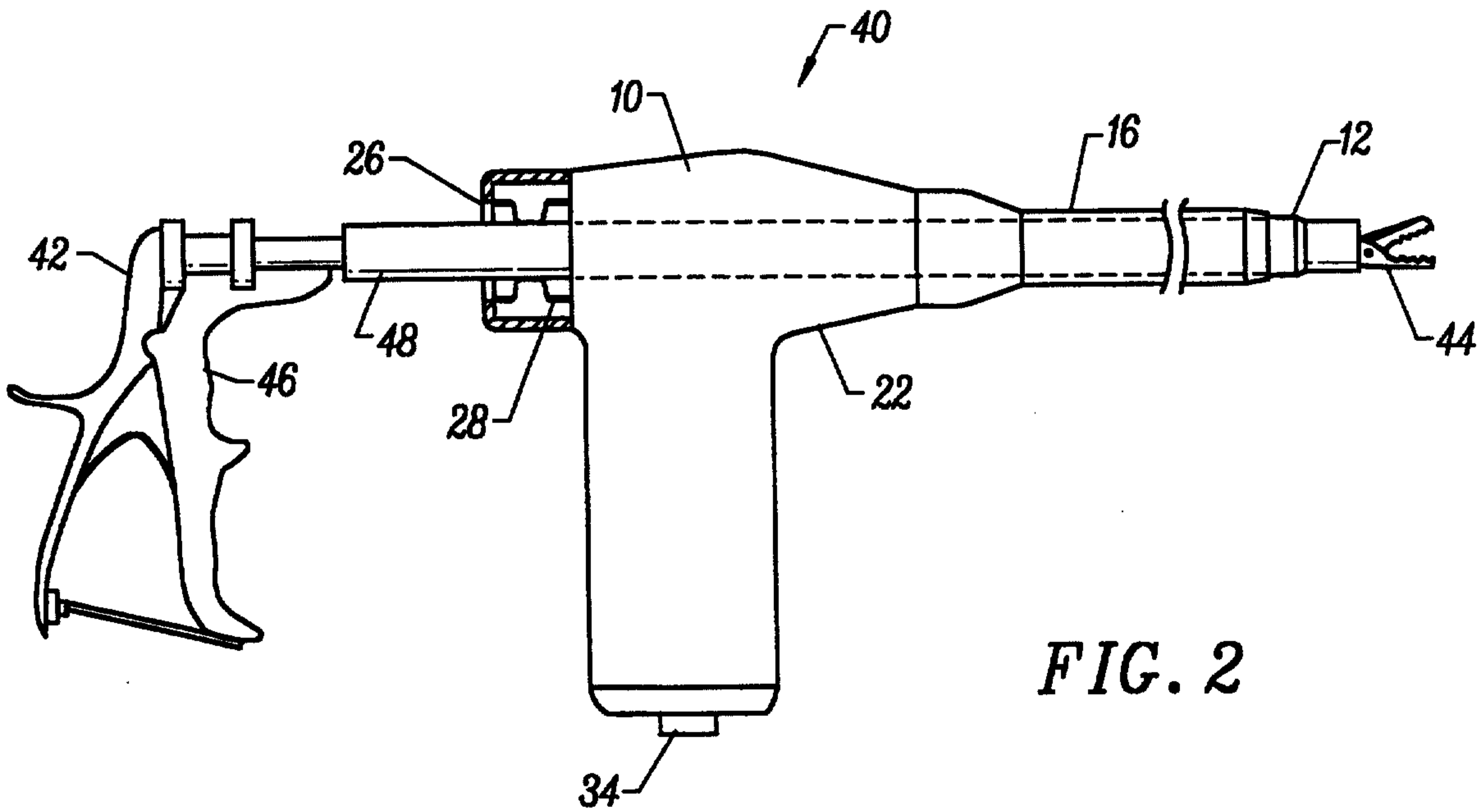

FIG. 2

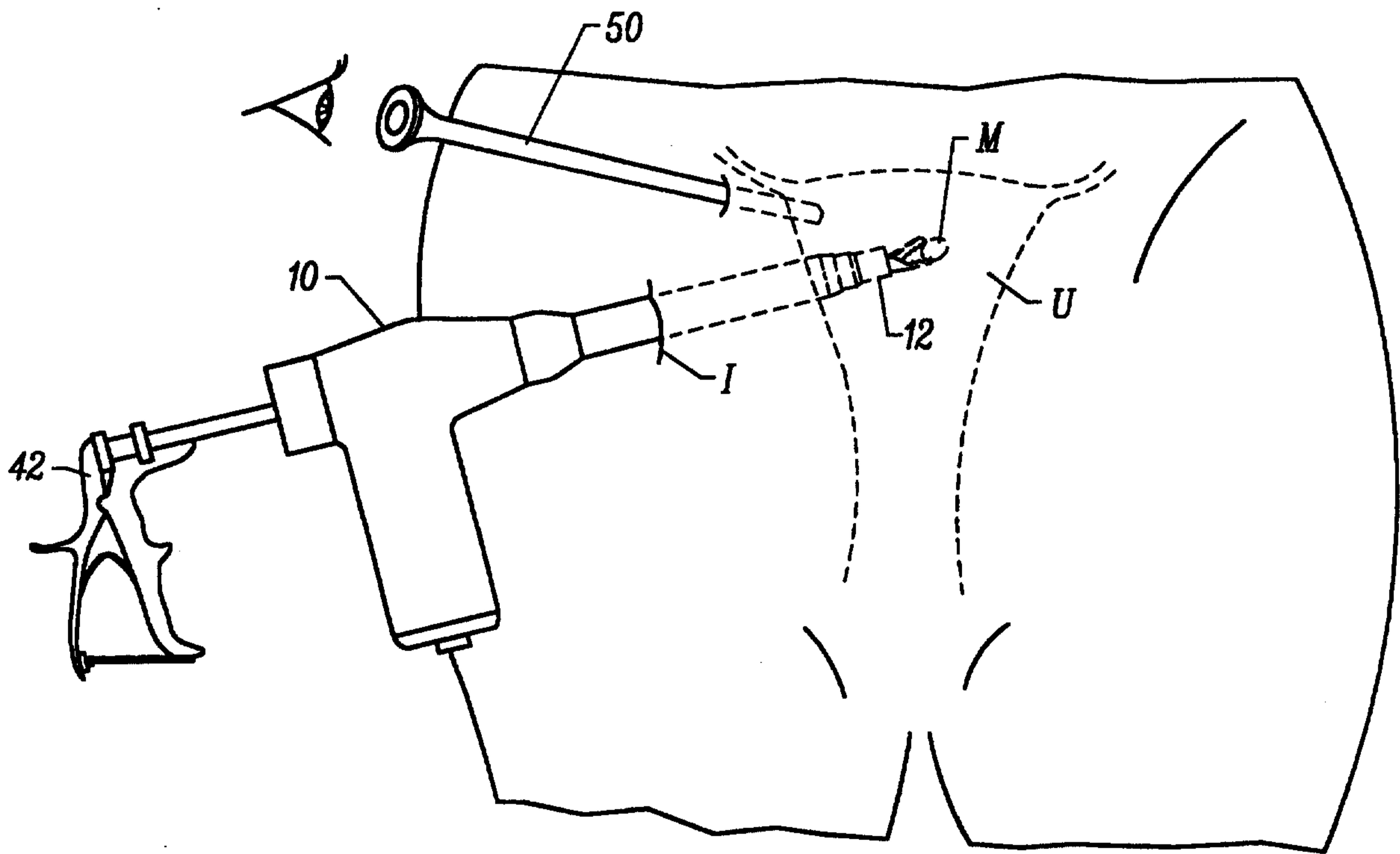

FIG. 3

3/7

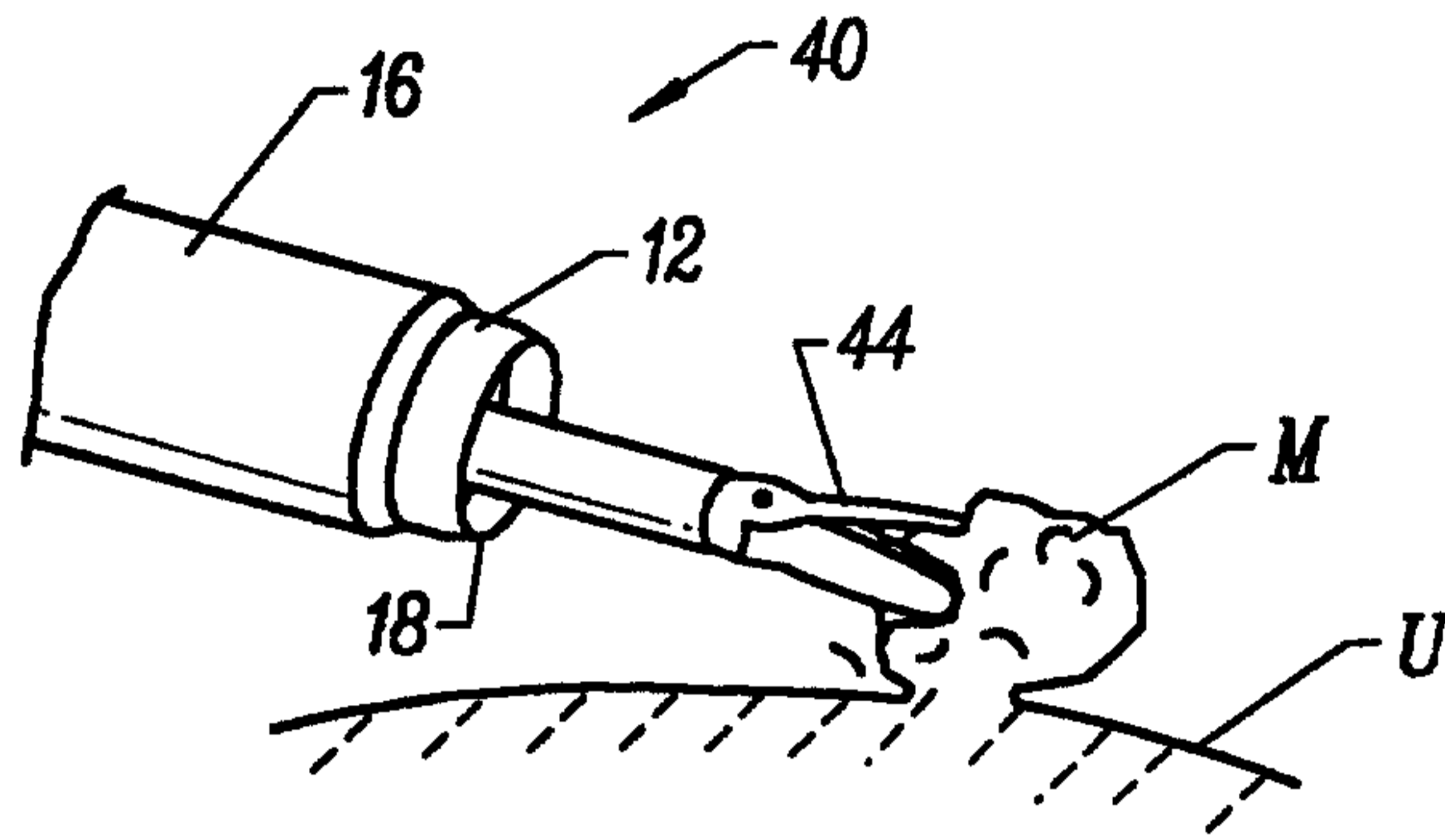

FIG. 4A

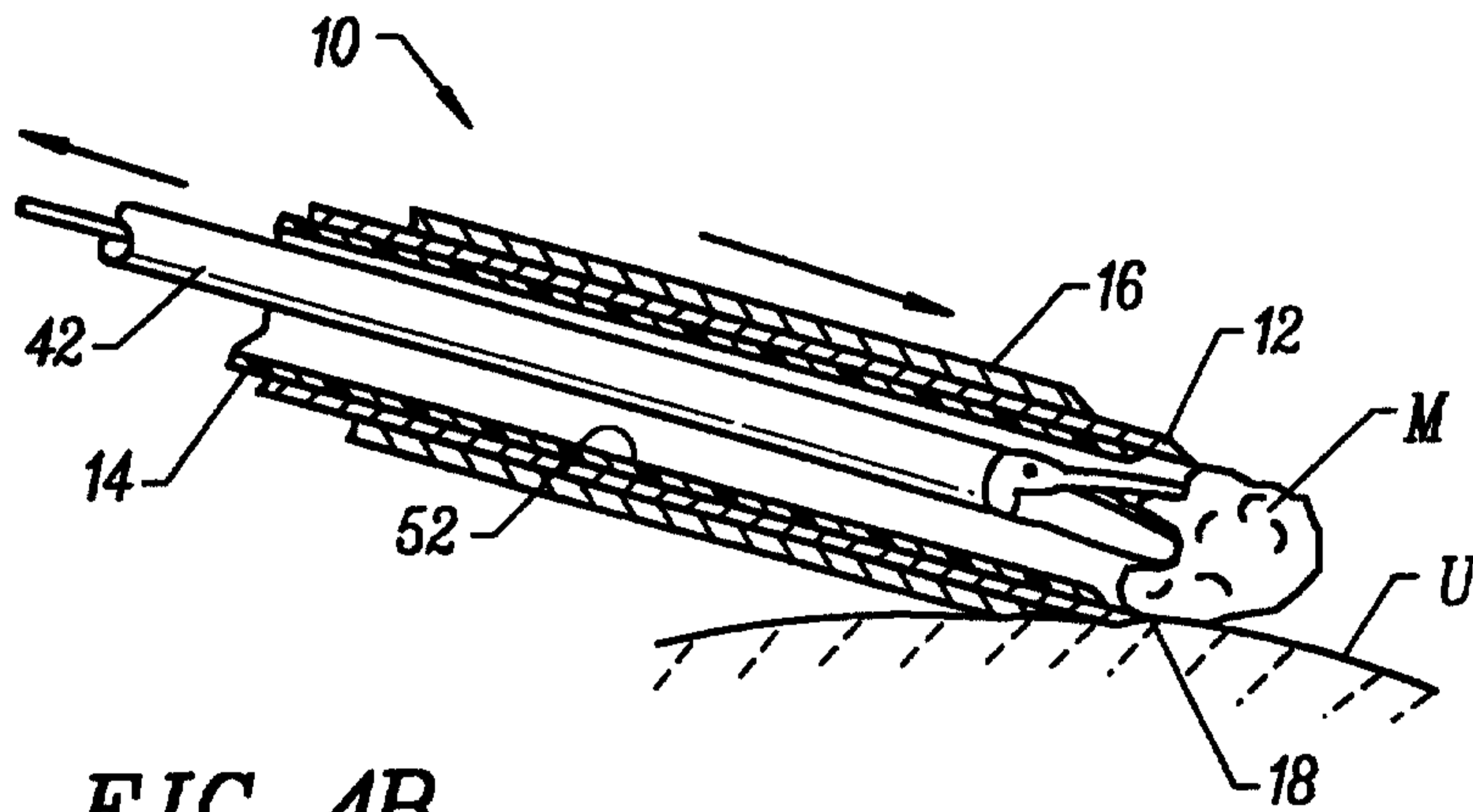

FIG. 4B

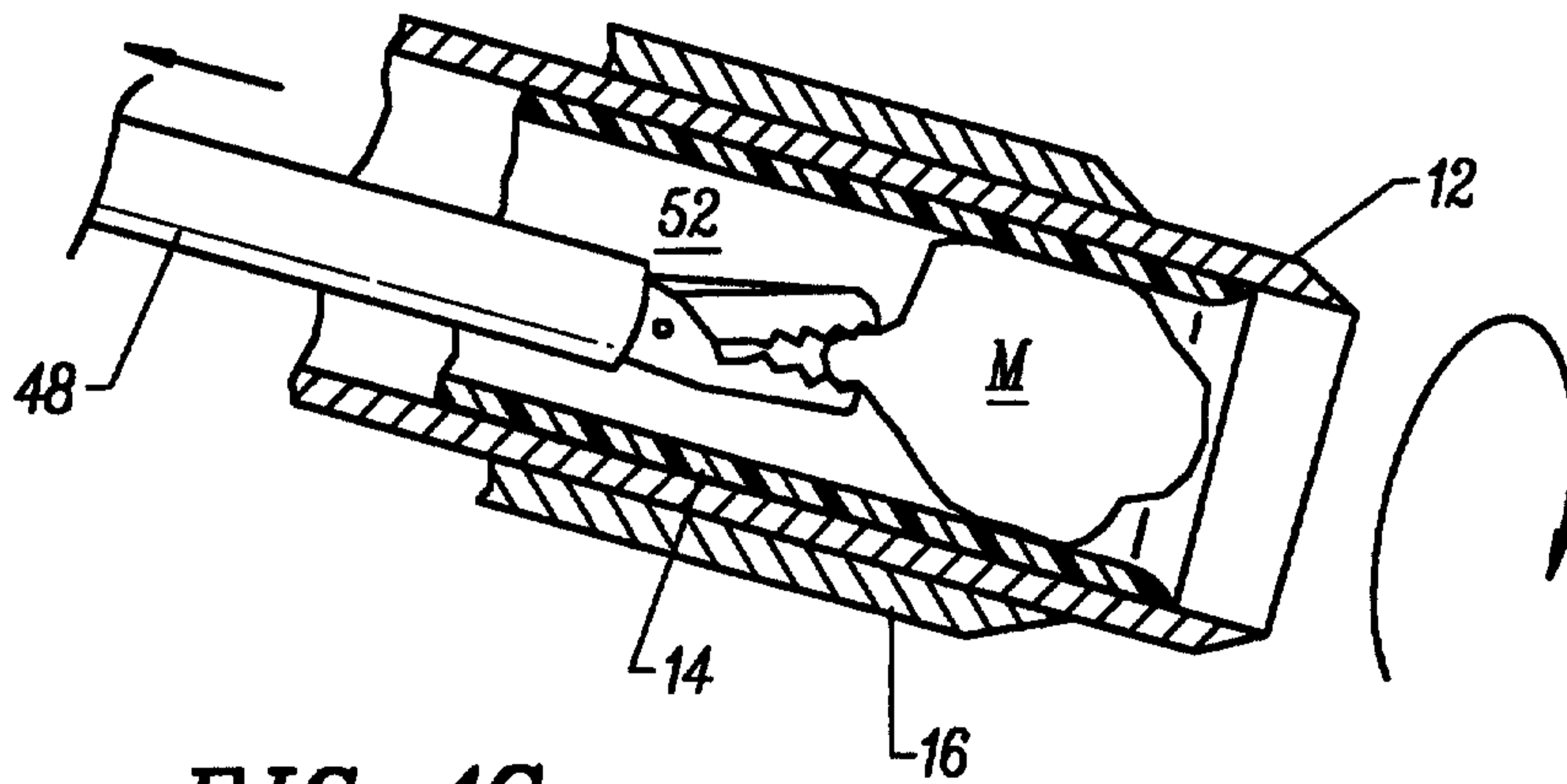

FIG. 4C

4/7

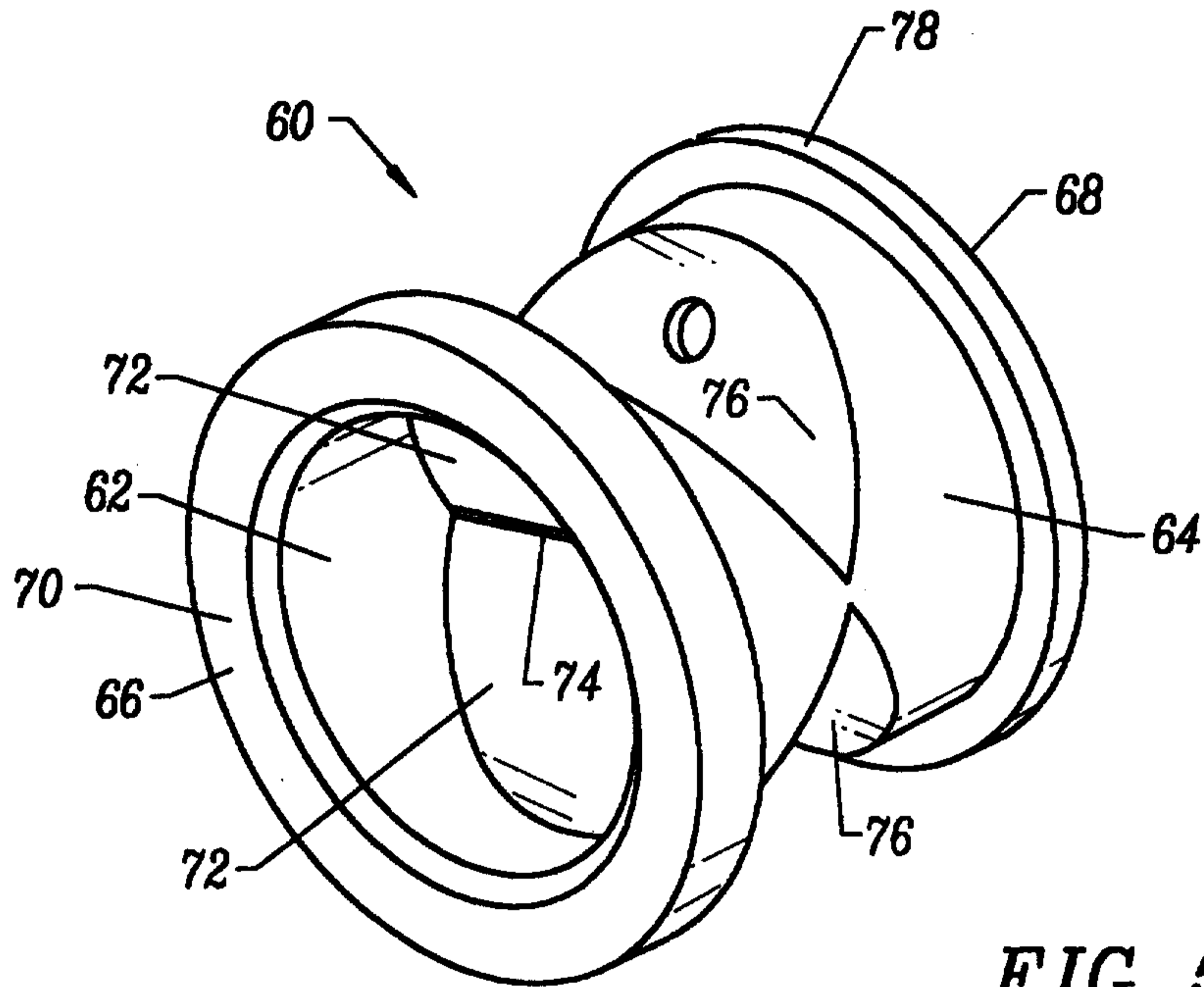

FIG. 5

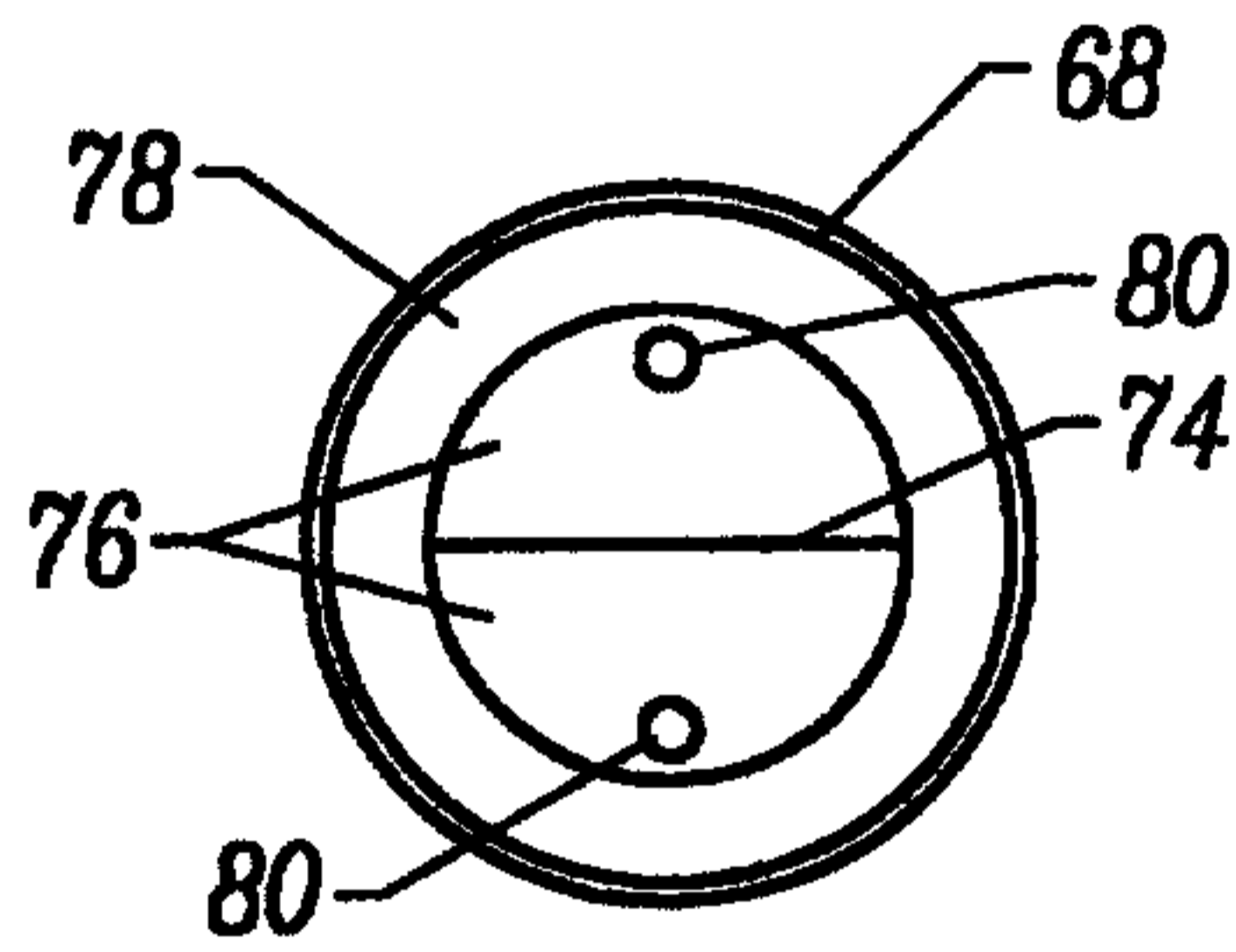

FIG. 5A

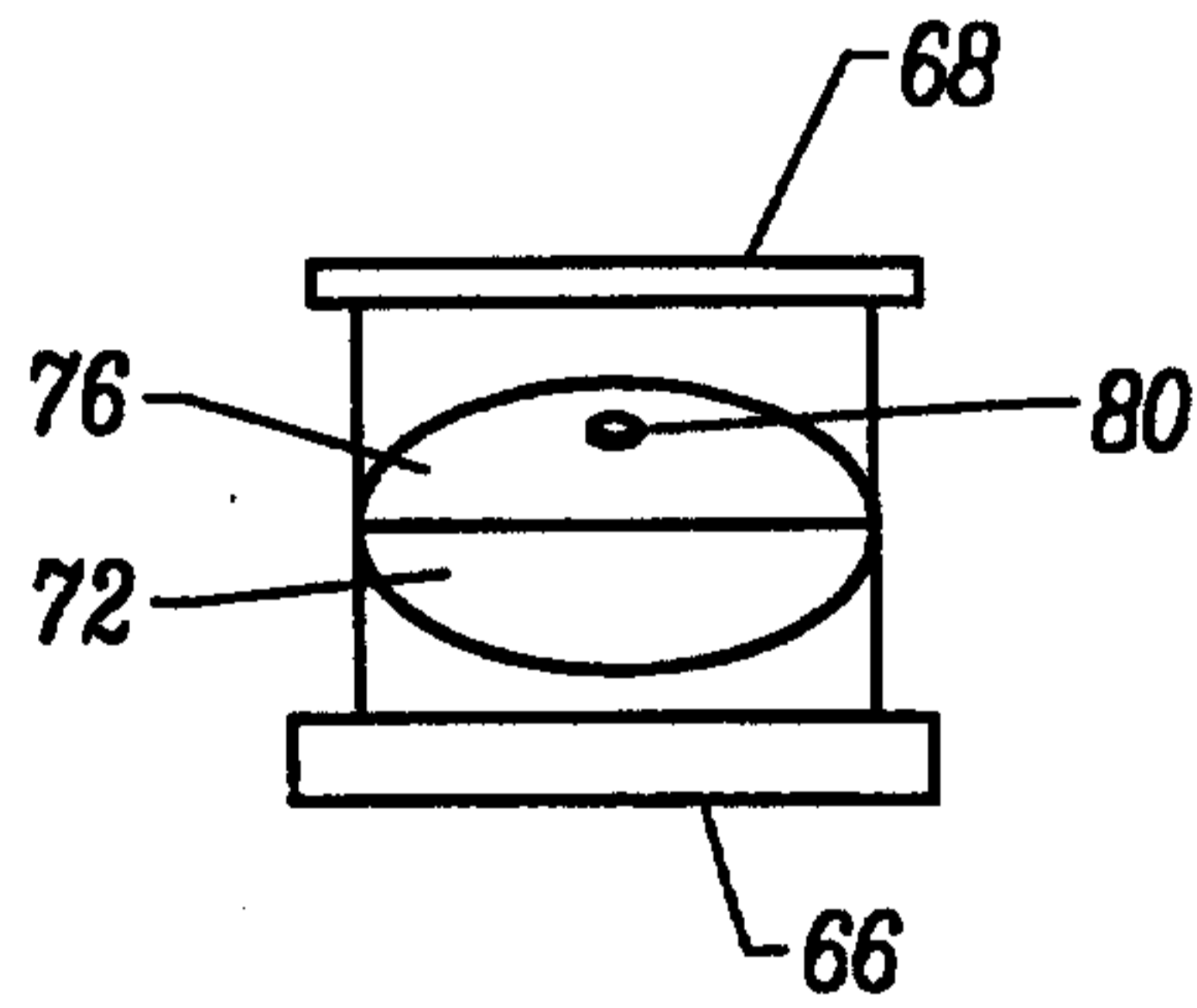

FIG. 5B

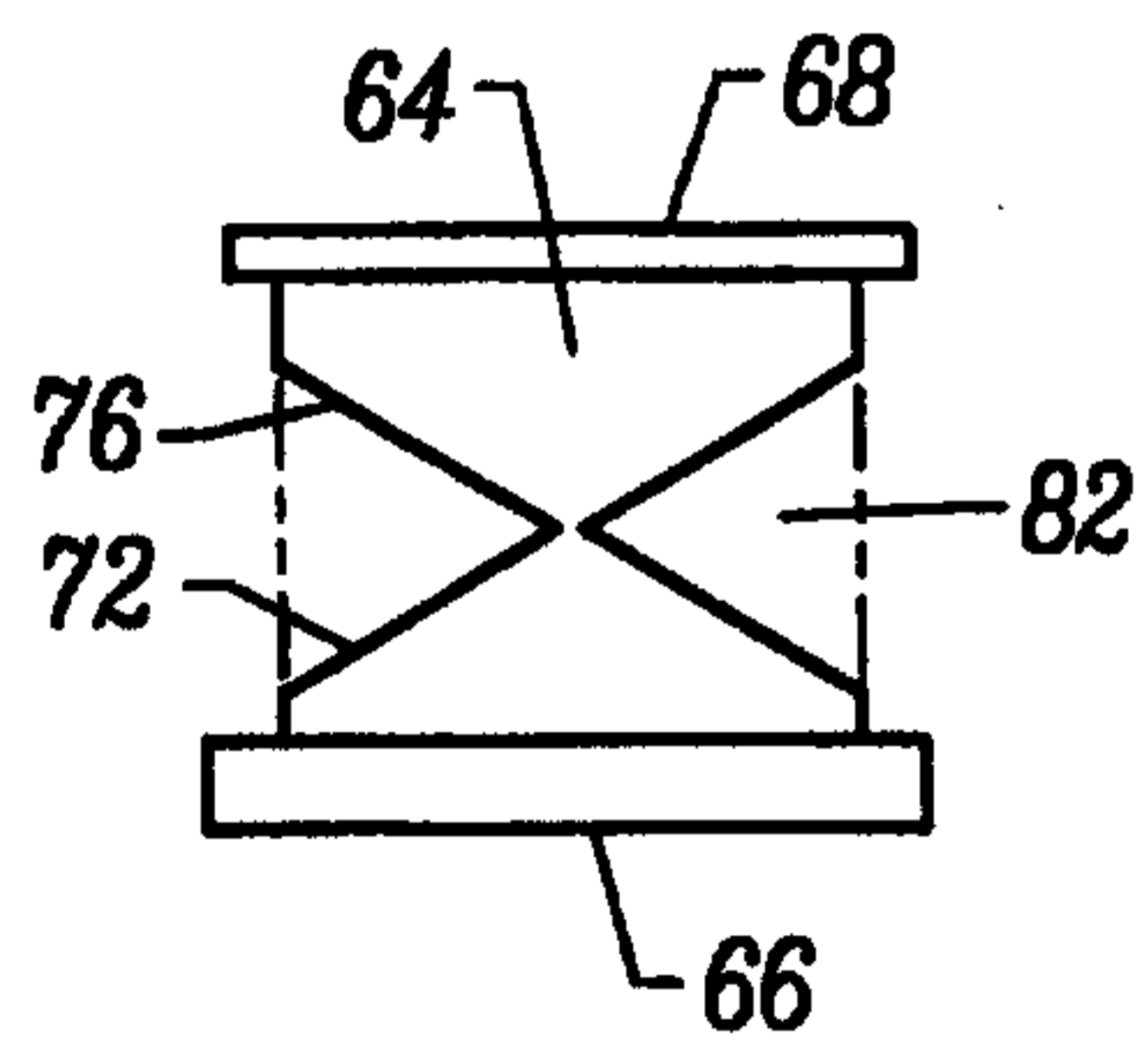

FIG. 5C

5/7

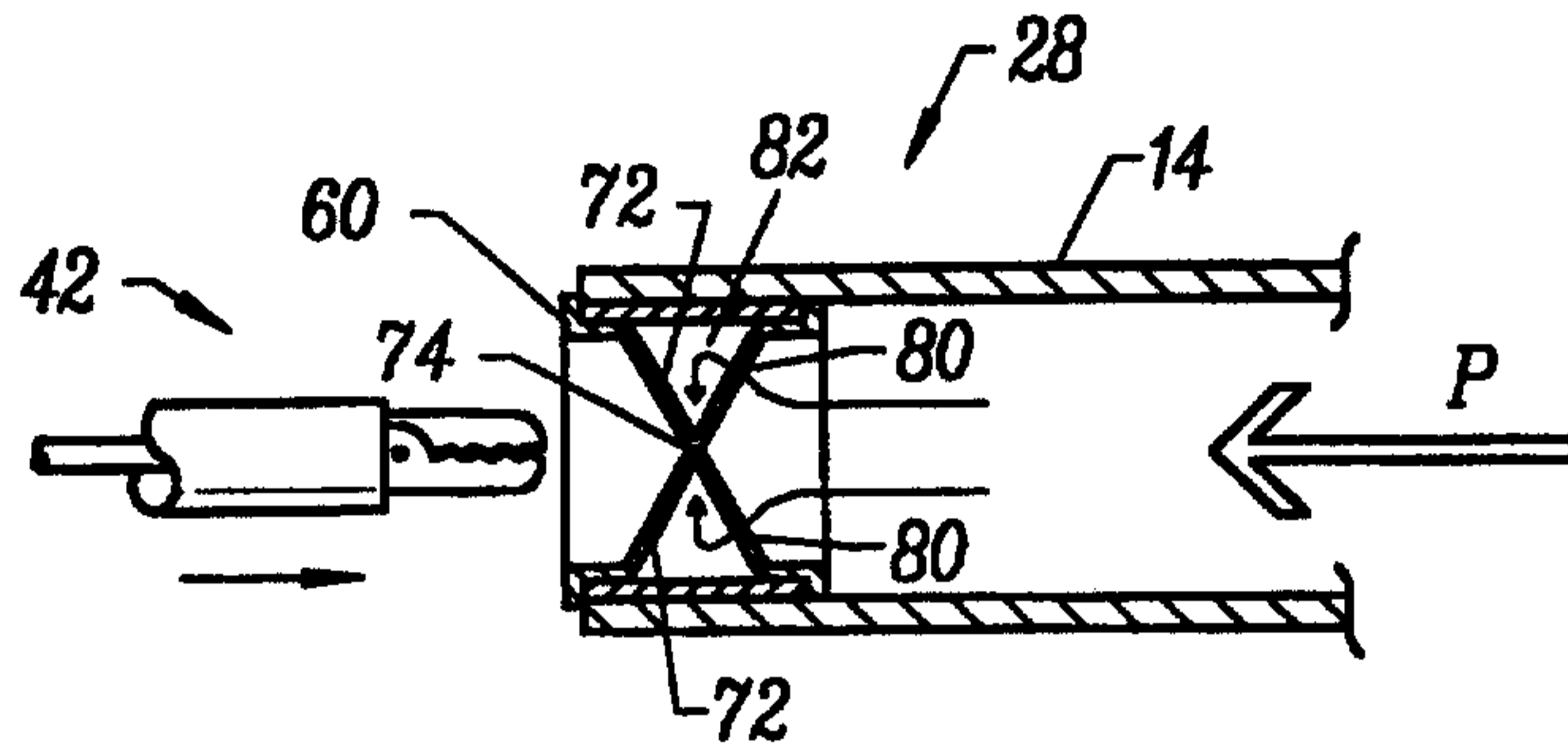

FIG. 6A

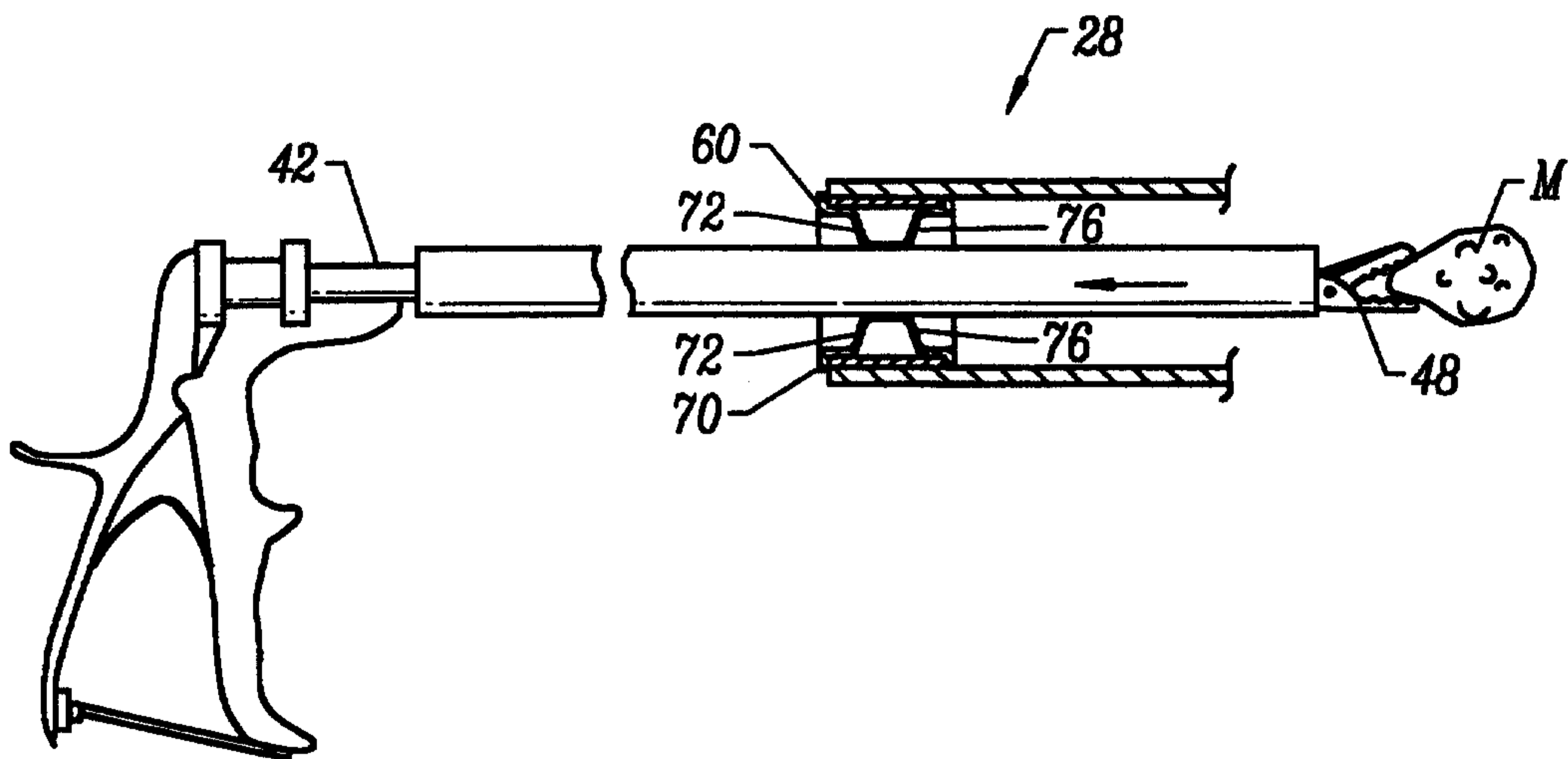

FIG. 6B

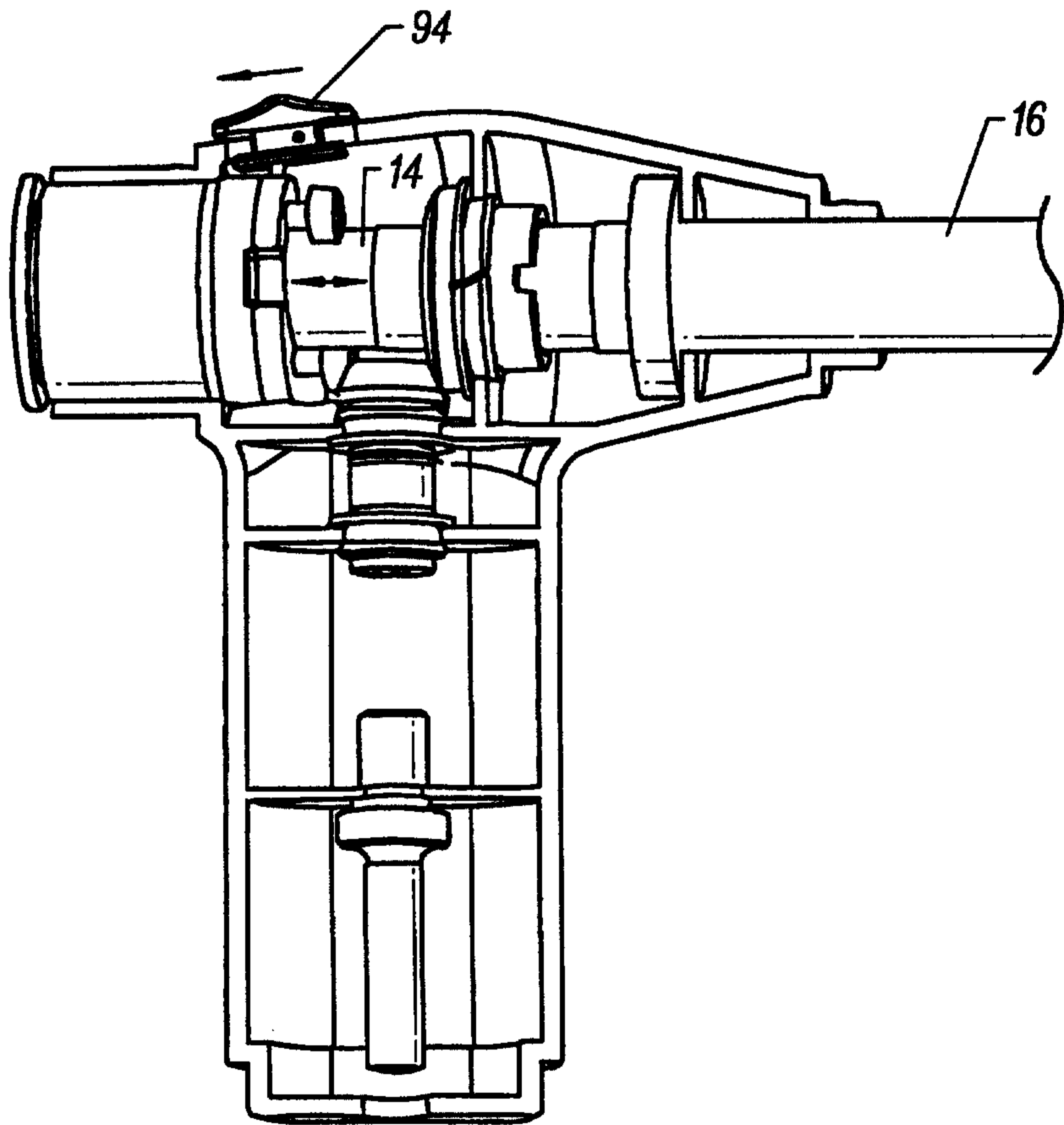
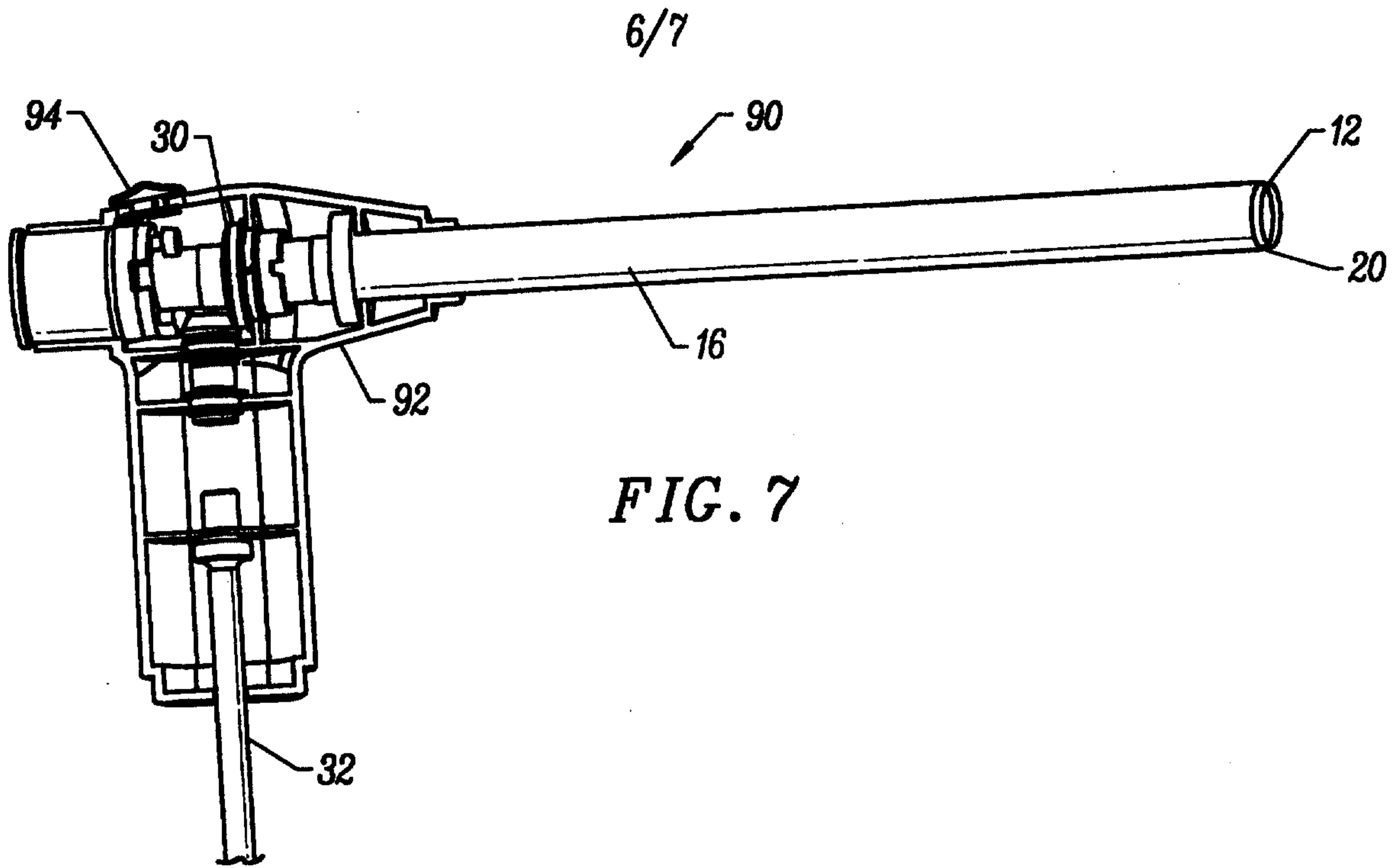

FIG. 7A
SUBSTITUTE SHEET (RULE 26)

7/7

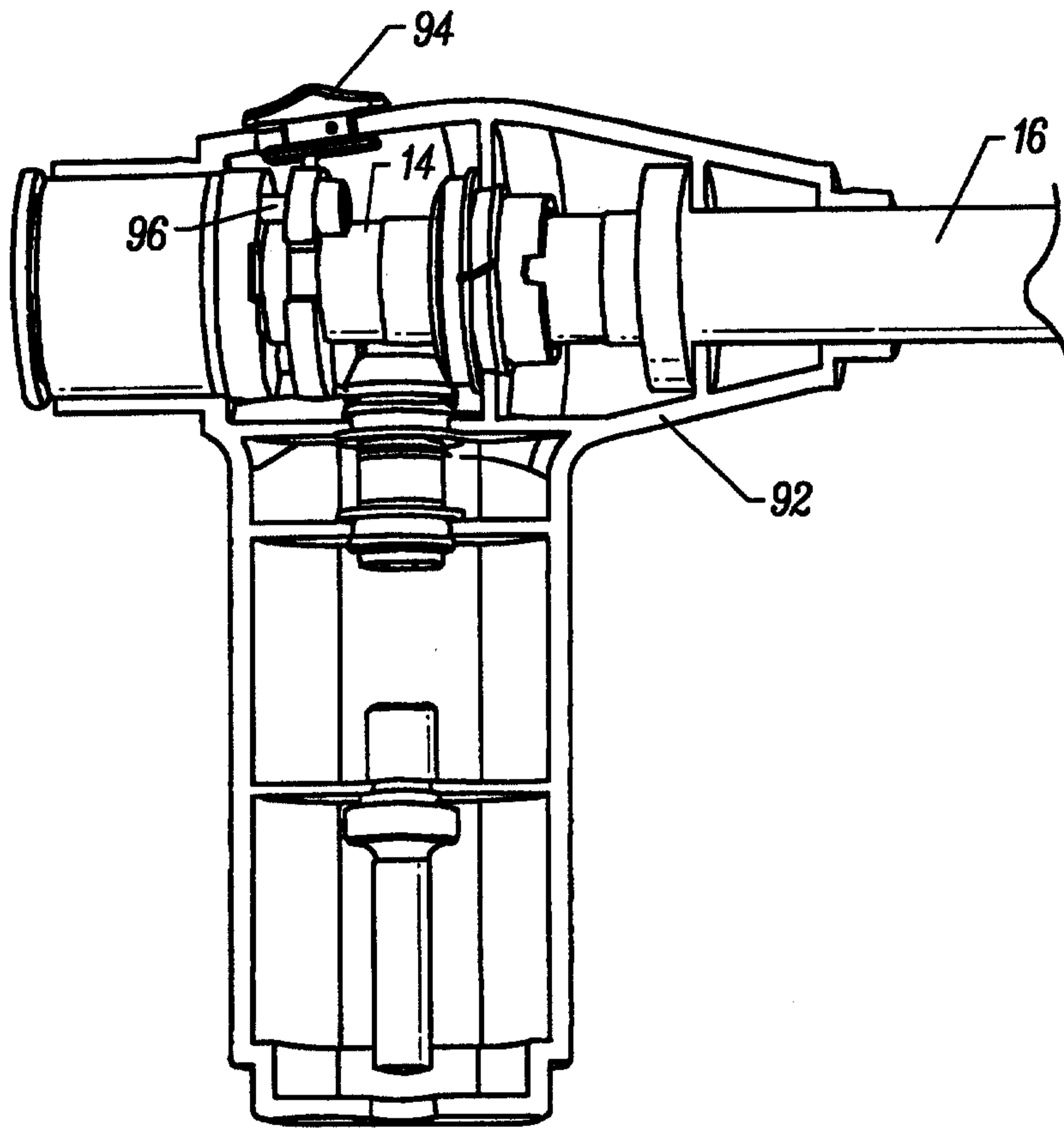

FIG. 7B

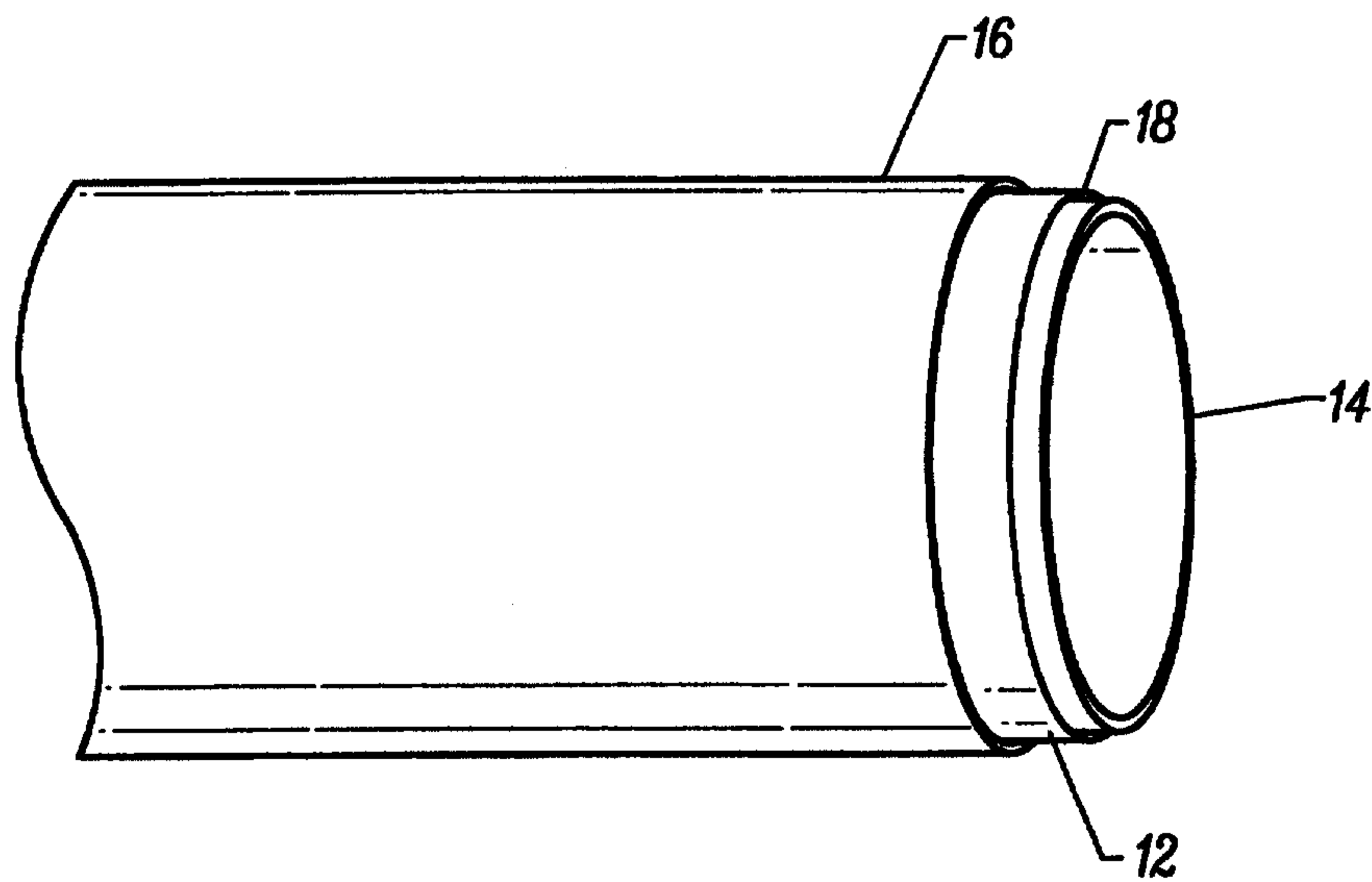

FIG. 7C