

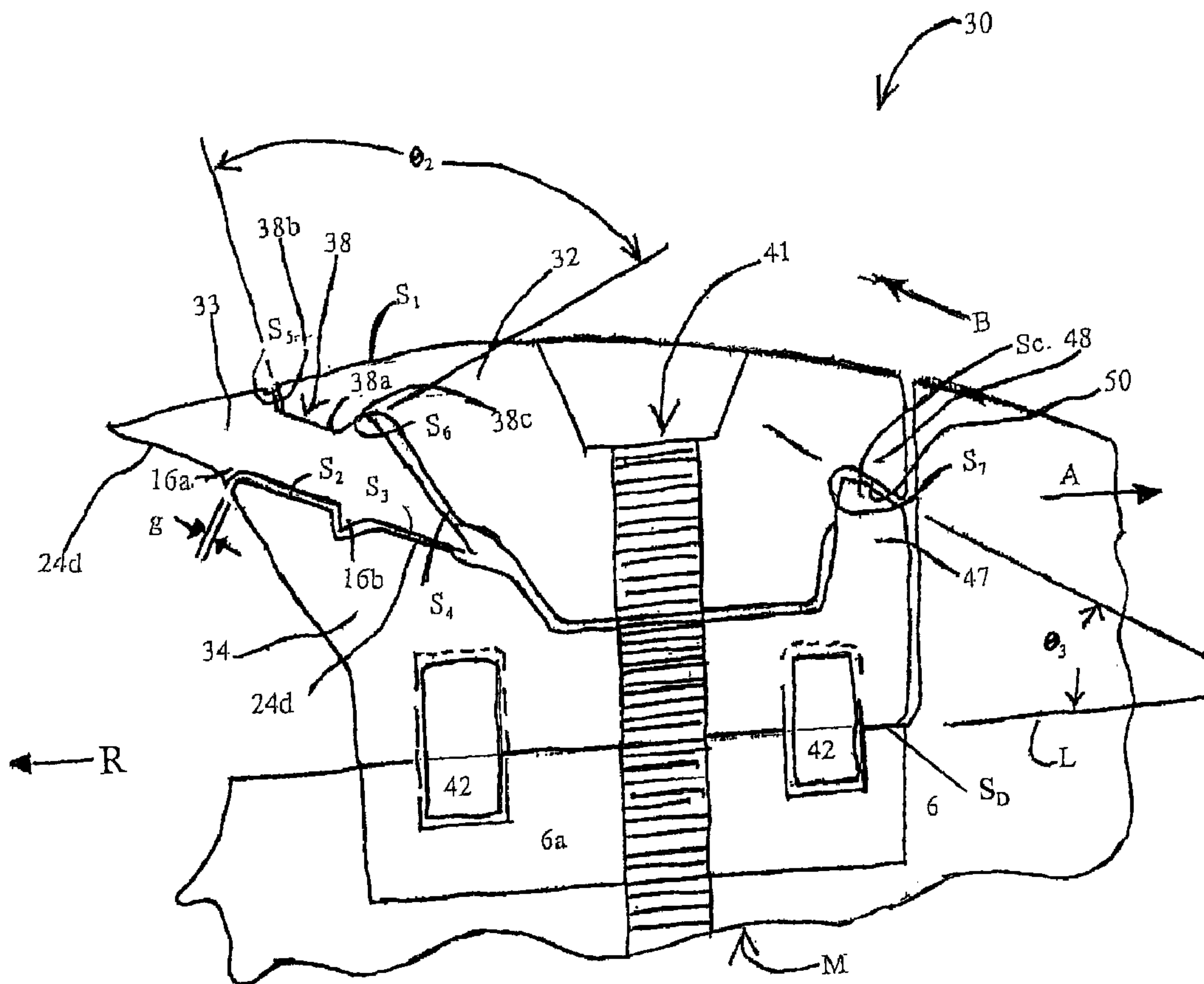

(22) Date de dépôt/Filing Date: 2003/12/19
 (41) Mise à la disp. pub./Open to Public Insp.: 2004/04/10
 (45) Date de délivrance/Issue Date: 2009/12/29
 (62) Demande originale/Original Application: 2 453 688
 (30) Priorité/Priority: 2003/09/25 (US10/672,989)

(51) Cl.Int./Int.Cl. *B27G 13/00* (2006.01),
B27C 1/00 (2006.01), *B27C 1/08* (2006.01)
 (72) Inventeurs/Inventors:
 MARSHALL, PETER J., US;
 STAGER, BRADLEY R., US;
 LUECKE, JOHN S., US;
 KNAPPETT, ANDREW, CA;
 RUSAW, BRIAN J., CA
 (73) Propriétaire/Owner:
 KEY KNIFE, INC., US
 (74) Agent: OYEN WIGGS GREEN & MUTALA LLP

(54) Titre : COUTEAU A BOIS A STABILITE AMELIOREE
 (54) Title: WOOD CUTTING KNIFE ASSEMBLY PROVIDING IMPROVED KNIFE STABILITY



(57) Abrégé/Abstract:

A wood chipping or cutting knife assembly providing improved knife stability. A number of control surfaces and other geometric features are provided to stabilize the knife in the assembly. An improved splitter is also provided for the knife assembly.

ABSTRACT

A wood chipping or cutting knife assembly providing improved knife stability. A number of control surfaces and other geometric features are provided to stabilize the knife in the assembly. An improved splitter is also provided for the knife assembly.

WOOD CUTTING KNIFE ASSEMBLY PROVIDING IMPROVED KNIFE
STABILITY

Background of the Invention

The present invention relates to a wood cutting knife assembly providing improved knife stability, for use in wood processing.

Many kinds of wood cutting apparatus are used for processing logs, lumber, or
5 wood refuse in a wood processing mill. For example, ring slicers, also termed ring
flakers or stranders, are generally used for manufacturing particle board, oriented strand
board, and fiberboard such as MDF. They convert logs, refuse lumber, chips, or other
articles of wood into flakes, wafers or strands for the manufactured board products. Disc
chippers are used to produce chips from waste wood, the chips also being used in
10 manufactured wood products. Wood cutting apparatus having conical heads or drum
style heads are used to produce squared lumber from logs.

All of these types of apparatus (hereinafter "wood cutting apparatus") employ
removable knives that are exposed to large, highly episodic cutting forces over prolonged
periods of time, yet the knives should be easily removable from the apparatus for
15 maintenance, repair or replacement, and must be held in the apparatus in as stable a
configuration as possible to produce high quality dimensioned lumber. It has proven
difficult to meet all of these requirements.

A significant advance in the art of wood cutting knife assemblies is represented by
Carpenter et al., U.S. Patent No. 4,997,018, disclosing a knife assembly for use with the

knife disclosed in Carpenter et al., U.S. Patent No. 4,850,408. The knife is double-sided, i.e., has dual cutting edges, to provide a second, alternative cutting edge when the first cutting edge becomes worn or damaged. The knife includes a keyway for receiving a mating projection of a counterknife, the knife being clamped between the counterknife and an outer clamping member. The keyway and mating projection index the knife to the cutting apparatus to which the knife assembly is mounted, and positively secure the knife to the cutting apparatus.

More recently, Schmatjen, U.S. Patent No. 5,819,826 discloses parallel ridges on the knife which straddle the projection of the counterknife. In addition to creating an effective keyway in the knife, the ridges deflect wood chips cut by the knife so as to reduce packing.

Bradstreet Jr. et al., U.S. Patent No. 5,271,440, discloses a double-sided knife having a serrated surface for mating reception with a complementary serrated surface of, in this case, the outer clamping member. While apparently more difficult to manufacture than the aforementioned Carpenter et al. knife assembly, the assembly of Bradstreet Jr. et al. is like many in the prior art that are provided in recognition of the need to positively index and secure the knife to the cutting apparatus.

A further significant advance in the art of knife assemblies for use in wood cutting apparatus is represented in PCT patent application Serial No. WO03/011541A1 by Loren R. Schuh and Tobias L. Simonsen to Key Knife, Inc. The knife disclosed therein has deflector ridges on a front side of the knife to receive a mating projection of the counterknife in the manner of Schmatjen, U.S. Patent No. 5,819,826, along with a recess in a back side of the knife to

receive a mating projection from the outer clamping member of the clamping assembly. The counterknife is relieved and formed so that a definite "three-point" contact is made between the assembly and the knife comprising two points on the bottom surface of the knife and one point on the top surface of the knife. The two points of contact on the
5 bottom surface of the knife are spaced as far apart as is practical, and the third point falls between these two points so that the knife is held in a stable configuration. Yet, the knife remains easy to remove from the assembly, and the complementary features provided in the outer clamping member and the knife actually improve the assembly in this regard.

So far as it is known, the prior art has not improved on this concept. However,
10 the present inventors have recognized opportunities for further improving the stability of the knife in a knife assembly for use in wood cutting apparatus.

Summary of the Invention

A wood chipping or cutting knife assembly providing improved knife stability according to a first aspect of the present invention provides a knife assembly for a wood
15 cutting apparatus including a knife having a cutting edge and opposing front and back sides extending from the cutting edge, and an outer clamping member adapted to receive the back of side of the knife. The front side of the knife has a first interlocking feature and the back side of the knife has a second interlocking feature. The outer clamping member is adapted to receive the back side of the knife, and the outer clamping member
20 has a third interlocking feature for interlocking with the second interlocking feature to index the knife to the outer clamping member. The second interlocking feature includes

opposed first plane surfaces, and the third interlocking feature includes corresponding opposed second plane surfaces defining a second positive angle that is slightly greater than the first positive angle.

According to a second aspect of the invention, A knife for use in a knife assembly
5 for a wood cutting apparatus is provided. The knife assembly includes a counterknife adapted for mounting to the apparatus and an outer clamping member adapted for mounting to the counterknife and for clamping the knife therebetween. The knife has an elongate axis and comprises two spaced apart cutting edges parallel to the elongate axis. The knife further includes opposing front and back sides extending between the cutting
10 edges, the front side having a first interlocking feature for interlocking to the counterknife and the back side having a second interlocking feature for interlocking to the outer clamping member. The first interlocking feature includes a channel extending parallel to said elongate axis, and the second interlocking feature includes opposed spaced apart plane surfaces defining a positive angle therebetween.

15 According to a third aspect of the invention, a knife assembly for a wood cutting apparatus includes a knife and a counterknife. The knife has an elongate axis and comprises two spaced apart cutting edges parallel to the elongate axis. The knife further includes opposing front and back sides extending between the cutting edges, the front side having a pair of spaced apart deflector ridges extending parallel to the elongate axis
20 and outwardly from the front side. The counterknife is adapted to receive the front side of the knife and to mount to the apparatus. The counterknife has an interlocking feature

providing substantially full contact with the knife between the deflector ridges, to index the knife to the counterknife.

According to a fourth aspect of the invention, a knife assembly for clamping a knife to a rotating wood cutting apparatus is provided. The knife has a cutting edge and opposing front and back sides extending from the cutting edge. The knife assembly includes a counterknife adapted to receive the front side of the knife and to mount to the apparatus at a mounting point. The knife assembly further includes an outer clamping member adapted to receive the back side of the knife and to mount to the counterknife. The counterknife includes a first heel portion, and the outer clamping member includes a second heel portion corresponding to the first heel portion. The first heel portion is adapted to oppose the second heel portion substantially along a line that is at a positive angle with respect to the direction of travel of the knife.

According to a fifth aspect of the invention, a knife assembly for a rotating wood cutting apparatus includes a knife, a counterknife, and an outer clamping member. The knife has a cutting edge and opposing front and back sides extending from the cutting edge. The counterknife is adapted to receive the front side of the knife and to mount to the apparatus at a mounting point and includes a first heel portion. The outer clamping member is adapted to receive the back side of the knife and to mount to the counterknife and includes a second heel portion corresponding to the first heel portion. The first heel portion is adapted to oppose the second heel portion substantially along a line that is at a positive angle with respect to the direction of travel of the knife.

According to a sixth aspect of the invention, a wood cutting apparatus is provided

including a rotating member for rotating about an axis of rotation, a knife, an outer clamping member, and a counterknife. The knife has a cutting edge and opposing front and back sides extending from the cutting edge. The front side has a first interlocking feature and the back side having a second interlocking feature. The outer clamping member is adapted to receive the back side of the knife, the outer clamping member having a third interlocking feature for interlocking with the second interlocking feature to index the knife to the outer clamping member. The second interlocking feature includes opposed first plane surfaces defining a first positive angle therebetween, wherein the third interlocking feature includes corresponding opposed second plane surfaces defining a second positive angle that is slightly greater than the first positive angle. The outer clamping member is adapted to mount to the counterknife. The counterknife is adapted to receive the front side of the knife and to mount to the rotating member. The counterknife has a fourth interlocking feature for interlocking with the first interlocking feature to index the knife to the counterknife.

15 According to a seventh aspect of the invention, a wood cutting apparatus is provided including a rotating member for rotating about an axis of rotation, a knife, and a counterknife.

The knife has an elongate axis and comprises two spaced apart cutting edges parallel to the elongate axis, and has opposing front and back sides extending between the cutting edges. The front side has a pair of spaced apart deflector ridges extending parallel to the elongate axis and outwardly from the front side. The counterknife is adapted to receive the front side of the knife and to mount to the rotating member. The counterknife has an

interlocking feature providing substantially full contact with the knife between the deflector ridges, to index the knife to the counterknife.

According to an eighth aspect of the invention, a wood cutting apparatus is provided including a rotating member for rotating about an axis of rotation, a knife, a counterknife, and an outer clamping member. The knife has a cutting edge and opposing front and back sides extending from the cutting edge. The counterknife is adapted to receive the front side of the knife and to mount to the rotating member at a mounting point and includes a first heel portion. The outer clamping member is adapted to receive the back side of the knife and to mount to the counterknife. The outer clamping member includes a second heel portion corresponding to the first heel portion. The first heel portion is adapted to oppose the second heel portion substantially along a line that is at a positive angle with respect to the direction of travel of the knife.

According to a ninth aspect of the invention, a wood cutting apparatus includes a rotating member for rotating about an axis of rotation, a knife having a cutting edge, a counterknife for mounting the knife to the rotating member, and a splitter. The counterknife has a way disposed below the cutting edge and accessible from outside the apparatus, and the splitter is adapted for manual insertion and removal through the way. In one embodiment, the splitter has at least one splitting portion including a curvilinear splitting edge for splitting articles of wood cut by the knife. In another embodiment, the splitter has two splitting edges substantially symmetrically disposed about an axis of said splitter.

A tenth aspect of the invention provides a splitter for a knife assembly for a wood

cutting apparatus. The knife assembly includes a knife having a cutting edge and a counterknife for mounting the knife to the apparatus. The counterknife has a way, and the splitter is adapted to fit in the way. In one embodiment, the splitter comprises at least one curvilinear splitting edge adapted for splitting articles of wood cut by the knife. In another embodiment, the splitter comprises two substantially symmetrically disposed splitting edges adapted for splitting articles of wood cut by the knife.

Brief Description of the Drawings

Figure 1 is a side elevation of a prior art cutting apparatus for cutting an article of wood.

Figure 2A is a cross-sectional view of a prior art article of wood.

Figure 2B is a cross-sectional view of the article of wood of Figure 2A being cut by a bottom head of the cutting apparatus of Figure 1.

Figure 2C is a cross-sectional view of the article of wood of Figure 2A being cut by side heads of the cutting apparatus of Figure 1

Figure 2D is a cross-sectional view of the article of wood of Figure 2A being cut by a top head of the cutting apparatus of Figure 1.

Figure 2E is a cross-sectional view of the article of wood of Figure 2A with a corner cut by the apparatus of Figure 3.

Figure 3 is a plan view of a prior art disc used in the apparatus of Figure 1.

Figure 4 is a cross-sectional view of a prior art knife.

Figure 5 is a cross-sectional view of a knife assembly for clamping the knife of

Figure 4 so as to provide "three-point contact" with the knife

Figure 6 is a cross-sectional view of a knife according to the present invention.

Figure 7 is a cross-sectional view of an alternative embodiment of a knife according to the present invention.

5 Figure 8 is a cross-sectional view of a knife assembly according to the present invention including the knife of Figure 6.

Figure 9 is a pictorial view of a single chipping or cutting disc with a knife assembly according to the present invention attached.

10 Figure 10 is a pictorial view of a head assembly according to the present invention including a plurality of stacked discs of the type shown in Figure 9.

Figure 11 is a plan view of a portion of the head assembly of Figure 10, showing interlocking of two adjacent disc segments.

15 Figure 12 is a cross-sectional view of a knife assembly according to the present invention shown with a first applied cutting force vector and with reactions shown exaggerated.

Figure 13 is a cross-sectional view of the knife assembly of Figure 12 with a second applied cutting force vector and with reactions shown exaggerated.

Figure 14 is a cross-sectional view of a knife assembly mounted to a chipping or cutting disc and incorporating a prior art "splitter."

20 Figure 15 is a side elevation of a knife assembly incorporating an alternative embodiment of a prior art splitter.

Figure 16 is an exploded view of the knife assembly and splitter combination of

Figure 15.

Figure 17 is a side view of a splitter according to the present invention.

Figure 18 is a side elevation of a knife assembly according to the present invention incorporating the splitter of Figure 17.

5 Figure 19 is a pictorial view of the knife assembly of Figure 18.

Figure 20 is a side sectional view of the knife assembly of Figure 18 with a lower portion of the counterknife removed.

Figure 21 is an exploded view of a knife assembly according to the present invention incorporating a second embodiment of a splitter according to the present
10 invention.

Detailed Description of Preferred Embodiments

The present invention, directed generally to a wood cutting knife assembly providing improved knife stability, includes a number of aspects which are described separately for clarity. It is not essential to the invention to provide all aspects, or to
15 provide any particular combination or sub-combination of the aspects, the claims reciting the subject matter that the applicants regard as their invention.

For context, Figure 1 shows a side elevation of a prior art wood cutting apparatus
11. Figures 2B - 2D show the manner of cutting an article of wood 8 with the apparatus, here a log as shown in Figure 2A. Heads B, T, S1 (Figure 2C) and S2 rotate about
20 respective axes of rotation "L." The bottom head B cuts a bottom side of the log, the top

head T cuts a top side of the log, and side heads S1 and S2 cut corresponding sides of the log to square the log. It should be understood that the particular head geometry and construction shown is selected for illustration purposes only.

Turning to Figure 3, each head described above includes a plurality of stacked disc portions 6 (hereinafter “disc”), each disc supporting a plurality of knives 2. The knives 2 are held in knife assemblies 3 comprising outer and inner clamping members 3a and 3b, respectively, where the inner clamping member is often referred to as a “counterknife.” Cutting edges 2a of the knives 2 are exposed for cutting the wood 11, the cutting edges extending along an axis that is perpendicular to the plane of the Figure. The knife assemblies are mounted to a rotating disc 6. The disc 6 and therefore the knives 2 rotate about an axis of rotation “L” that is also perpendicular to the plane of the Figure in a direction of rotation “R.” The double-sided knives 2 also include cutting edges 2b that are not exposed unless the knives are removed and turned end-for-end. Additional knives 4 may also be provided with cutting edges parallel to the plane of the Figure so that, together, the knives 2 and 4 may cut corners in the wood 8. For example, if the article of wood 8 is a log as shown in Figures 2A, the knives 2 and 4 may be used to cut the corner C, as shown in Figure 2E.

For comparison with the present invention, Figure 4 shows a cross-sectional view of the prior art knife described in Schmatjen, U.S. Patent No. 5,819,826 is shown. The knife is elongate with an elongate axis perpendicular to the plane of the Figure (not shown). The double-sided knife has two cutting edges 14a, 14b, two “deflector ridges” 16a, 16b on a front side 17 of the knife, and a semi-circular recess 18 on a back side

19 of the knife, which joins the front side 17 at the cutting edges 14a and 14b. The deflector ridges extend outwardly from the front side 17 and define a channel that provides an interlocking feature for interlocking with the counterknife.

This function could be provided by other structures, such as the keyway disclosed in U.S. Patent No. 4,850,408. However, the deflector ridges also include concave curved outer surfaces 7 for deflecting wood chips from the counterknife, the outer surfaces 7 terminating in a line 8 which is seen as a point in the Figure.

Also for comparison with the present invention, Figure 5 shows a cross-sectional view of a knife assembly 20 for attachment to a disc 6, for clamping the knife 12 so as to provide "three-point contact" with the knife. The knife assembly 20 includes an outer clamping member 22 and an inner clamping member or counterknife 24. The counterknife 24 includes two lands 24a and 24b for making contact with the front side 17 (Figure 4) of the knife 12, and is otherwise relieved so that no other contact is made with the knife. The upper clamping member includes a projection 26 that is received by the recess 18 (Figure 4) of the knife, and is otherwise relieved so that no other contact is made with the knife.

The counterknife 24 includes a heel portion 45 that provides a backstop for a corresponding heel portion 46 of the outer clamping member 22. The heel portions 45 and 46 are spaced apart by a tolerancing gap g_1 in a circumferential direction "A" that is substantially parallel to the circumferential surface of the disc 6 in the local area of the counterknife (shown flat in Figure 5 as an approximation), and are otherwise slidingly disposed with respect to one another by virtue of the angle of the opposed surfaces S_A and

S_B of the respective heel portions so that limited relative movement of the counterknife and outer clamping member is possible along this direction.

Now turning to Figure 6, a cross-sectional view of a knife 33 according to the present invention is shown. The knife is elongate with an elongate axis that is perpendicular to the plane of the Figure. The double-sided knife has two cutting edges 31a, 31b, and a first interlocking feature 35 comprising two deflector ridges 36a, 36b on a front side 37 of the knife, and a second interlocking feature 38 on a back side 39 of the knife, which joins the front side 37 at the cutting edges 31a and 31b. The first interlocking feature 35 is adapted to mate with a corresponding feature in the counterknife, to index the knife to the counterknife, and the second interlocking feature 38 is adapted to mate with a corresponding feature in the outer clamping member, to index the knife to the outer clamping member. The interlocking features may serve additional functions, as do the deflector ridges.

The second interlocking feature 38 includes opposed planar surfaces 38b and 38c defining a positive (i.e., non-zero) included angle θ_1 reference to which is made below. The planar surfaces 38b and 38c are spaced apart by an intermediating planar surface 38a and make equal angles θ_e with respect to the intermediating planar surface. Figure 7 shows an alternative knife 33 having the same features that is “top ground” at A_1 and A_2 .

Turning to Figure 8, a knife assembly 30 according to the present invention including the knife 33 is shown. The knife assembly 30 has an outer clamping member 32 with an outer surface S_1 tracing an arcuate line. The surface S_1 is adapted to constrain the article of wood, as the knife assembly travels along its arc of rotation, by pressing on the freshly cut surface of the wood, to keep the article of wood from bucking the cutting

apparatus. Such a shape for the surface S_1 is disclosed in the assignee's U.S. Patent No. 6,164,352.

5 The knife assembly 30 further includes a counterknife 34 for cooperating with the outer clamping member 32 to clamp the knife. A bolt (not shown) extends through a bolt-hole 41 through both the outer clamping member and the counterknife into the disc 6, or alternatively, into a block 6a in the disc (as shown). In addition, one or more pins 42 are preferably provided in corresponding receiving holes in the counterknife 34 and the disc 6 (or block 6a) to index the counterknife to the disc.

10 Contact with the knife 33 is controlled by six control surfaces $S_2 - S_7$, shown exaggerated for purposes of illustration. The control surface S_2 is provided by the counterknife 34 between the deflector ridges 16 of the knife 33 and, unlike the land 24a (Figure 5), provides substantially "full contact" over the area therebetween. Particularly, referring to Figure 6, the knife has a surface 24c that has a width w_c , and the control surface S_2 makes full contact with the surface 24c over substantially the entire width w_c .

15 The control surface S_3 of the counterknife corresponds to the land 24b (Figure 5). Again referring to Figure 6, the knife has two surfaces 24d adjacent the respective deflector ridges, the surfaces 24d having widths w_d . Unlike the prior art knife's contact with the land 24b (Figure 5), the control surface S_3 makes contact with the unexposed surface 24d of the knife 33 as shown in Figure 8 over a substantial area, e.g., at least 50% of the width w_d , rather than confining contact to a single point of contact. Preferably, the surfaces 24c, 24d, S_2 and S_3 are all planar; however, this is not essential.

The control surfaces $S_4 - S_7$ are provided by the outer clamping member 32. The

control surface S_4 is a “stop” for movement of the knife in the circumferential direction “A.”

The control surfaces S_5 and S_6 act as wedges within the second interlocking feature 38 of the knife 33. Particularly, the control surfaces S_5 and S_6 bear against the side surfaces 38b and 38c, respectively, of the second interlocking feature 38. Wedging action is preferably provided by ensuring that the included angle θ_2 defined by the control surfaces S_5 and S_6 (Figure 8) is slightly greater than the corresponding angle θ_1 defined by the surfaces 38b and 38c. Exemplary values for θ_1 and θ_2 , respectively, are 70 and 72 degrees, although the angles can range from about 50 - 90 degrees and the difference between the angles can range from about 1/4 to 7 degrees, and more preferably about 1 - 4 degrees.

The remaining control surface S_7 engages the counterknife 34 to lock the counterknife to the outer clamping member and prevent movement of the outer clamping member with respect to the counterknife in the direction “A.”

In addition to the control surfaces $S_2 - S_7$, the invention may advantageously provide a gap “g” within the range of about 0.001" to 0.008", and more preferably about 0.005", between the counterknife 34 and the exposed deflector ridge, e.g., 16a. The gap is small enough to prevent significant loading of wood chip material, yet ensures that the load exerted on the knife 33 by the outer clamping member 32 is borne by the control surfaces S_2 and S_3 .

The counterknife 34 includes a heel portion 47 and the outer clamping member 32 has a corresponding heel portion 48. By contrast to the heel portions 45 and 46 of the prior art, the heel portions 47 and 48 of the present invention are not spaced apart by virtue of the contact between the counterknife and the outer clamping member at the

control surface S_7 . Opposed surfaces S_C and S_D of the heel portions are provided at an angle θ_3 according to the invention. The angle θ_3 is taken with respect to a line "L" that lies in the direction "R" of travel of the knife, which is typically the arc of rotation of the apparatus (the disc is drawn as though it has zero curvature in Figure 8) at the place of attachment of the assembly 30 thereto, i.e., at the mounting point "M." The angle θ_3 therefore defines the direction "B" shown. Relative movement of the outer clamping member 32 with respect to the counterknife in directions having angles less than θ_3 is prevented by the heel portions 47 and 48. Preferably, the angle θ_3 ranges from about 20 - 40 degrees, and more preferably the angle is about 30 degrees.

10 The heel portion 47 provides a backstop for the corresponding heel portion 48. Particularly, the control surface S_7 of the heel portion 48 abuts the heel portion 47 and thereby prevents movement of the outer clamping member 32, with respect to the counterknife 34, in the direction "A," which is opposite to the direction of rotation "R" of the disc.

15 Figure 10 illustrates a further stabilizing aspect of the present invention. A number of discs 6 (see Figure 9) may be stacked as disc segments in a head assembly 50. The disc segments 6 are angularly staggered with respect to the axis of rotation L so that the knives of adjacent disc segments, such as the knives 2a and 2b respectively of the disc segments 6a' and 6b', are not adjacent one another. Referring to Figure 11, the knives are slightly wider, in the direction of the axis L, than the disc segments, and the disc segments are relieved at R slightly to receive overhanging portions of the knives of adjacent disc segments, so that the disc segments interlock with one another. Controlling

the amount of this relief laterally constrains the knives and stabilizes their disposition in the disc segments.

Figures 12 and 13 illustrate, respectively, the assembly of Figure 8 wherein the knife 33 is subject to two different force vectors F_1 and F_2 . The forces F are applied by the log or lumber as it is cut or chipped. Movement of the knife in response to each of the forces F is controlled by the aforescribed features. The knife pivots between the outer clamping member 32 and the counterknife 34 about pivot point P_1 in response to the force F_1 in Figure 12. The knife is restrained at C_1 at the surface 38b of the knife by the control surface S_5 (see Figure 8) of the outer clamping member. The knife also pivots about point P_2 in response to the force F_2 in Figure 13 and is restrained at C_2 and C_3 . The knife is restrained at C_2 at the surface 38c of the knife by the control surface S_6 (Figure 8) of the outer clamping member, and is restrained at C_3 at the outer surface 39 (Figure 6) of the knife by the control surface S_4 (Figure 8) of the outer clamping member.

Turning to Figure 14, a prior art "splitter" 50a is shown for use in a knife assembly 51 comprising a knife 52, an outer clamping member 54 and a counterknife 56. The splitter is disposed downstream of the knife and is used to split wood chips cut by the knife. Figure 14 shows, in addition to a block 6a in the disc 6 for receiving the knife assembly 51, a clamp 55 fastened to the disc 6 by a bolt 57 that engages the block 6a, a feature that may be employed in connection with the present invention as well. The splitter has a splitting edge 58 that is formed from a plate-like body portion 50a_b that fits into a cavity or way in the counterknife 56, while an upper portion 50a_a of the splitter is cylindrical and fits in a hole "H" extending into the counterknife 56. Replacing the

splitter requires withdrawing the splitter through the hole "H" which is somewhat inconvenient. It is also recognized herein that the geometry of the splitter 50a and the splitting edge 58 are limiting in the range of positions and angles of the splitting edge 58 that can be made available with respect to the cutting edge 53 of the knife 52, and that
5 this lack of flexibility may result in a failure to achieve functionality.

Turning to Figures 15 and 16, a second prior art splitter 50b is shown for use in the knife assembly 51. In this embodiment, the splitter is mounted to the counterknife 56, here between the counterknife and the disc 6 (or the block 6a). The splitter is held in place by clamping bolts 59 bearing on the counterknife 56, and is located with a dowel
10 pin 57. It is recognized herein that the splitter 50b being disposed underneath the counterknife is inherently limited in positioning the splitting edge 58 in proximity to the cutting edge of the knife.

Turning now to Figures 17 - 20, a splitter 60 according to the present invention is shown for use with the knife assembly 30 of Figure 8. The splitter is shown in Figure 17.
15 It is shown attached to the counterknife in Figure 19, and with a lower portion of the counterknife removed in Figure 20.

The splitter 60 is received in a cavity or way 61 (Figure 19) in the counterknife via a non-interference fit, so that the splitter can be installed and removed from the counterknife, through the way 61, by hand. The splitter has a beveled splitting portion 62
20 that projects outwardly from the counterknife 34 into the stream of wood chips cut by the knife 33 indicated by the arrow in Figure 21. The splitting portion 62 has a knife-like edge 63 resulting from beveling the splitter to create, preferably for ease of

manufacturing, flat bevel portions 65a and 65b (Figure 17). The knife-like edge is preferably convexly curved such as shown. A flat bevel portion 65c forming an underside of the splitting portion 62 is shown in Figure 19 may also be provided to provide support for the knife edge 63.

5 Referring to Figure 20, the splitter 60 is held in the way 61 of the counterknife by a set-screw 70. The set-screw is adapted to bear on a clamping surface 64 (Figure 17) of the splitter to hold the splitter in place. A bottom surface 68 of the splitter is adapted to rest on the disc 6 (or the block 6a) when the knife assembly 30 is mounted on the disc. The bottom surface 68 may include an aperture 66 for clearing the pin 35, the pin 35 may
10 be moved out of the way of the splitter as in Figure 20 (where it is disposed behind the splitter with respect to the cross-sectional plane), or the splitter may terminate short of the pin 35 as in the embodiment shown in Figure 21.

The curvilinear splitting edge 63 provides increased control in locating the splitting edge at any desired position and angle with respect to the cutting edge of the
15 knife. The splitter is also easily removable for repair or replacement by virtue of its being adapted to be removed and installed through the way 61. In addition, the splitter is preferably bilaterally symmetric about an axis of symmetry "SY" as shown in Figure 17 and in that form includes dual splitting portions 62 and corresponding knife-like edges 63. This provides the outstanding advantage that, when the exposed splitting edge
20 becomes dulled during use, the splitter can be easily removed from the counterknife 34 simply by loosening the set-screw 70, removing the splitter from the knife assembly through the way 61, rotating the splitter 180 degrees about the axis SY, and reinstalling

the splitter in the counterknife 34 through the way 61 to provide a fresh splitting edge.

It is to be recognized that, while a specific wood chipping or cutting knife assembly providing improved knife stability has been shown and described as preferred, other configurations and methods could be utilized, in addition to configurations and methods already mentioned, without departing from the principles of the invention.

The terms and expressions which have been employed in the foregoing specification are used therein as terms of description and not of limitation, and there is no intention of the use of such terms and expressions to exclude equivalents of the features shown and described or portions thereof, it being recognized that the scope of the invention is defined and limited only by the claims which follow.

CLAIMS

1. A knife assembly for a wood cutting apparatus, comprising:
 - a knife having a cutting edge and opposing front and back sides extending from said cutting edge, said front side having a first interlocking feature and said back side having a second interlocking feature, said second interlocking feature including opposed first plane surfaces defining a first positive angle; and
 - an outer clamping member adapted to receive said back side of said knife, said outer clamping member having a third interlocking feature for interlocking with said second interlocking feature to index said knife to said outer clamping member, said third interlocking feature including corresponding opposed second plane surfaces defining a second positive angle that is greater than said first positive angle,wherein the difference between said first positive angle and said second positive angle is in the range of about 1/4 - 7 degrees.

2. A knife assembly for a wood cutting apparatus, comprising:
 - a knife having a cutting edge and opposing front and back sides extending from said cutting edge, said front side having a first interlocking feature and said back side having a second interlocking feature, said second interlocking feature including opposed first plane surfaces defining a first positive angle; and
 - an outer clamping member adapted to receive said back side of said knife, said outer clamping member having a third interlocking feature for interlocking with said second interlocking feature to index said knife to said outer clamping member, said third interlocking feature including

corresponding opposed second plane surfaces defining a second positive angle that is greater than said first positive angle,

wherein said first positive angle is about 70 degrees.

3. The knife assembly of claim 2, wherein said second positive angle is about 72 degrees.

4. The knife assembly of any one of claims 1 to 3, further comprising a counterknife adapted to receive said front side of said knife and to mount to the apparatus, said counterknife having a fourth interlocking feature for interlocking with said first interlocking feature to index said knife to said counterknife, said outer clamping member adapted to mount to said counterknife.

5. The knife assembly of any one of claims 1 to 3, wherein said opposed first plane surfaces are spaced apart by an intermediating plane surface, said first plane surfaces defining said first positive angle therebetween, said first plane surfaces defining respective equal angles with respect to said intermediating plane surface.

6. A knife assembly for a wood cutting apparatus, comprising:
a knife having a cutting edge and opposing front and back sides extending from said cutting edge, said front side having a first interlocking feature and said back side having a second interlocking feature, said second interlocking feature including opposed first plane surfaces defining a first positive angle; and
an outer clamping member adapted to receive said back side of said knife, said outer clamping member having a third interlocking feature for interlocking with said second interlocking feature to index said knife to said outer clamping member, said third interlocking feature including corresponding opposed second plane surfaces defining a

second positive angle that is greater than said first positive angle,

wherein:

said knife has an elongate axis and comprises two spaced apart cutting edges parallel to said elongate axis, and opposing front and back sides extending between said cutting edges, said front side having a pair of spaced apart deflector ridges extending parallel to said elongate axis and outwardly from said front side,

said assembly further comprising:

a counterknife adapted to receive said front side of said knife and to mount to the apparatus, said counterknife having a fourth interlocking feature providing substantially full contact with said knife between said deflector ridges, to index said knife to said counterknife, said knife including respective planar surfaces adjacent each of said deflector ridges extending out to the corresponding cutting edges and defining a cross-sectional width, and wherein said counterknife includes a planar surface adapted to make contact with a selected one of said planar surfaces of said knife,

and wherein:

said third interlocking feature of said outer clamping member and said second interlocking feature of said knife index said knife to said outer clamping member so that, in cooperation with said contact, a small gap exists between an exposed one of said deflector ridges and said counterknife, said gap ranging from about 0.001" - 0.008".

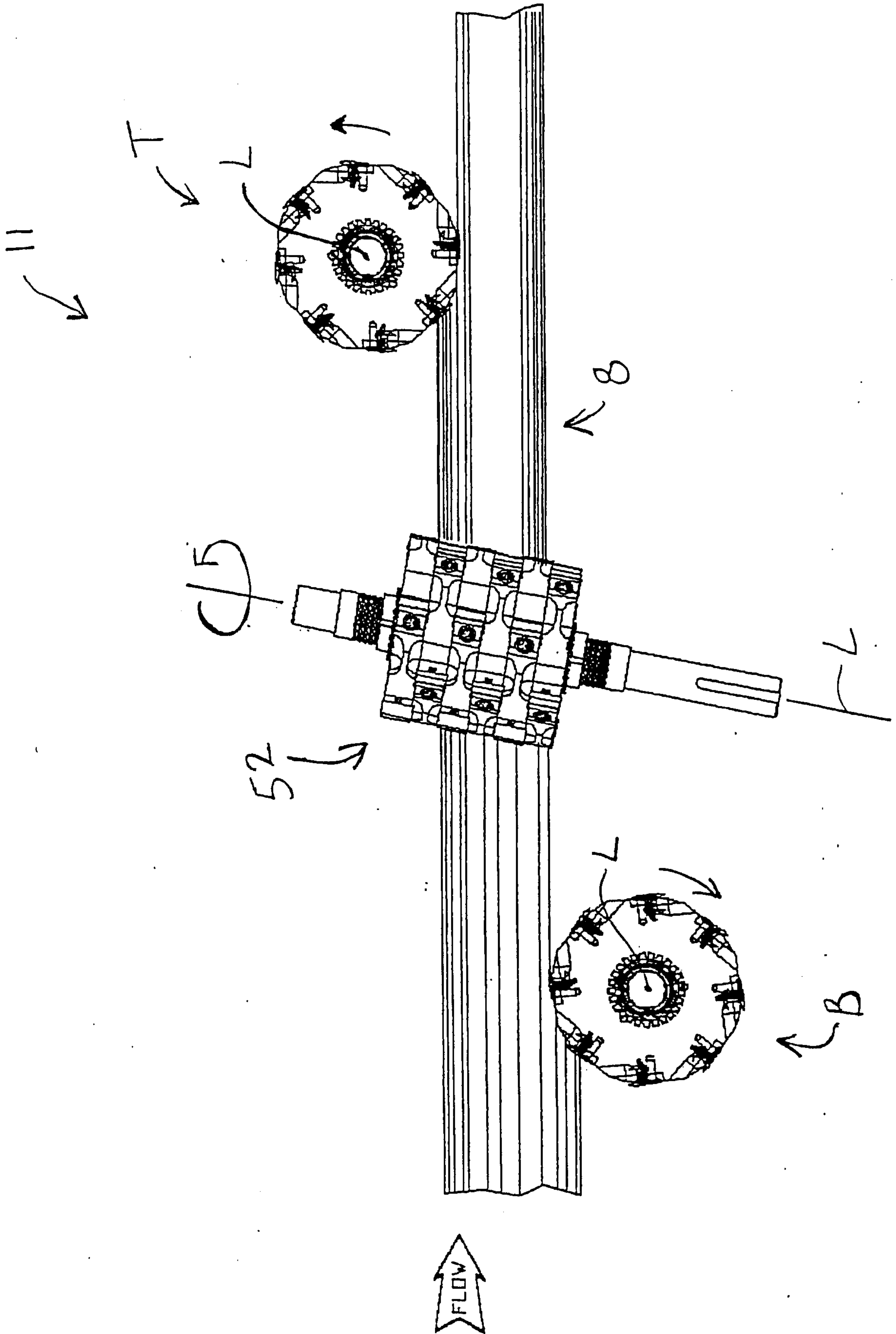

FIG. 1 (Prior Art)

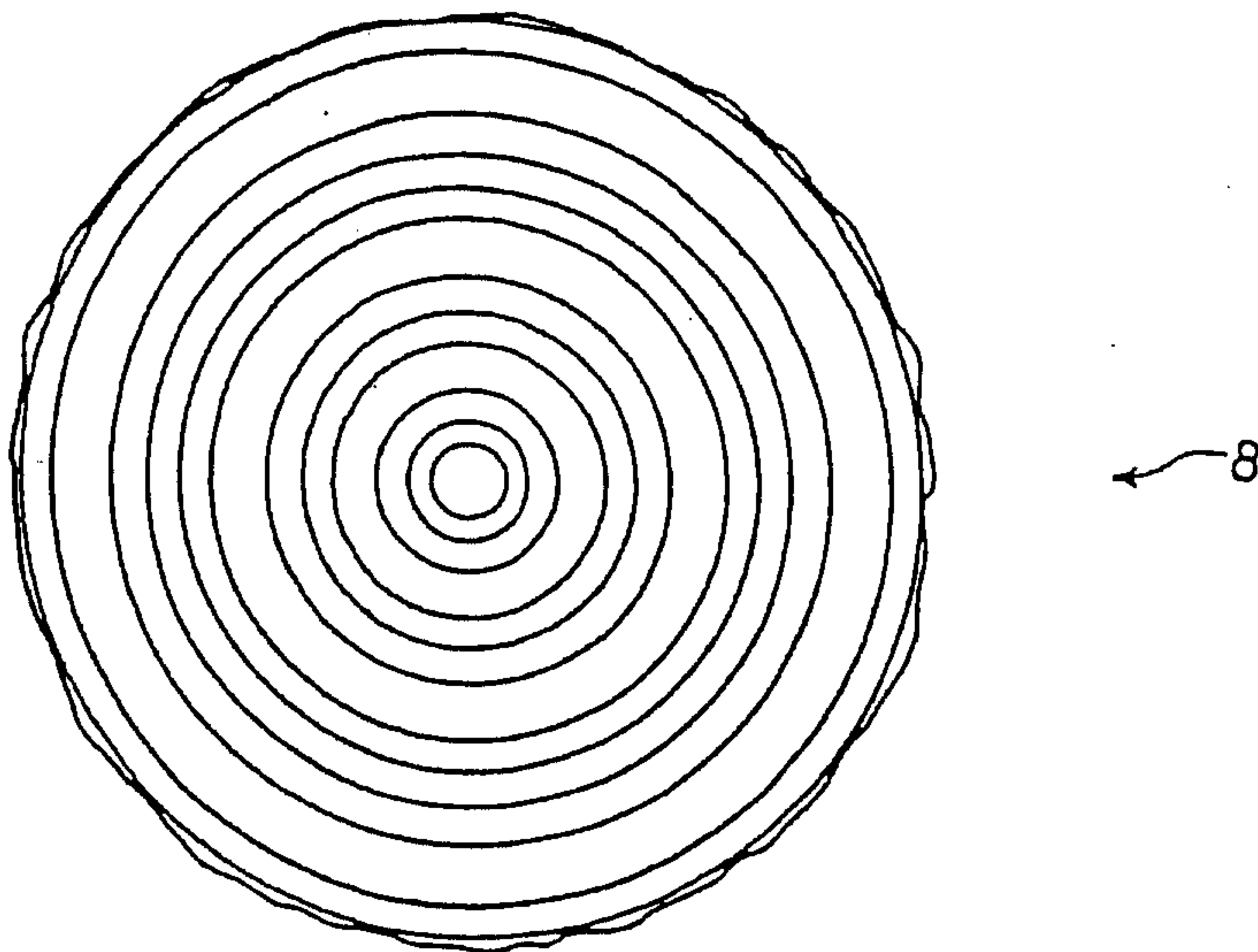

FIG. 2A (Prior Art)

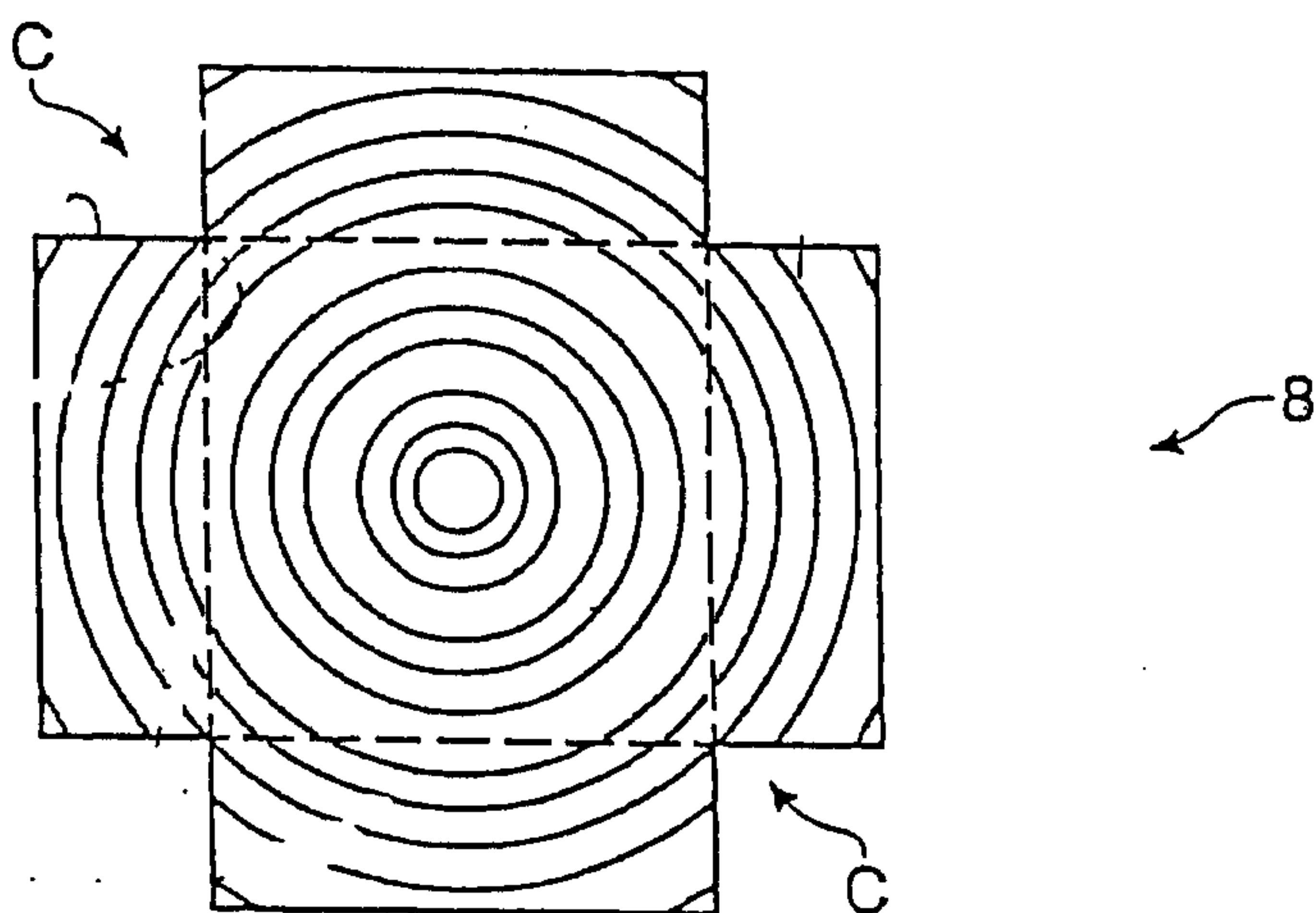

FIG. 2E (Prior Art)

FIG. 2B (Prior Art)

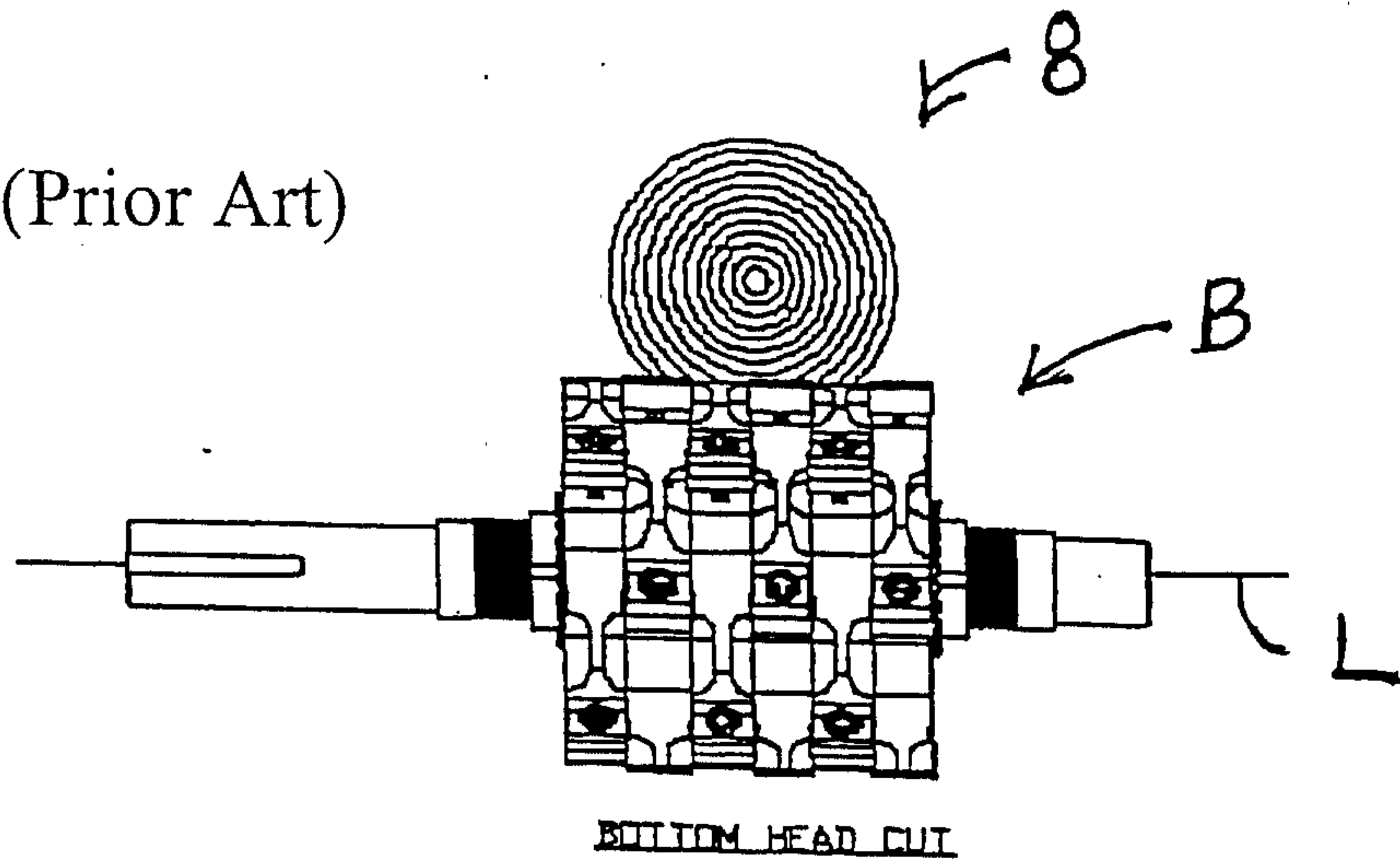

FIG. 2C (Prior Art)

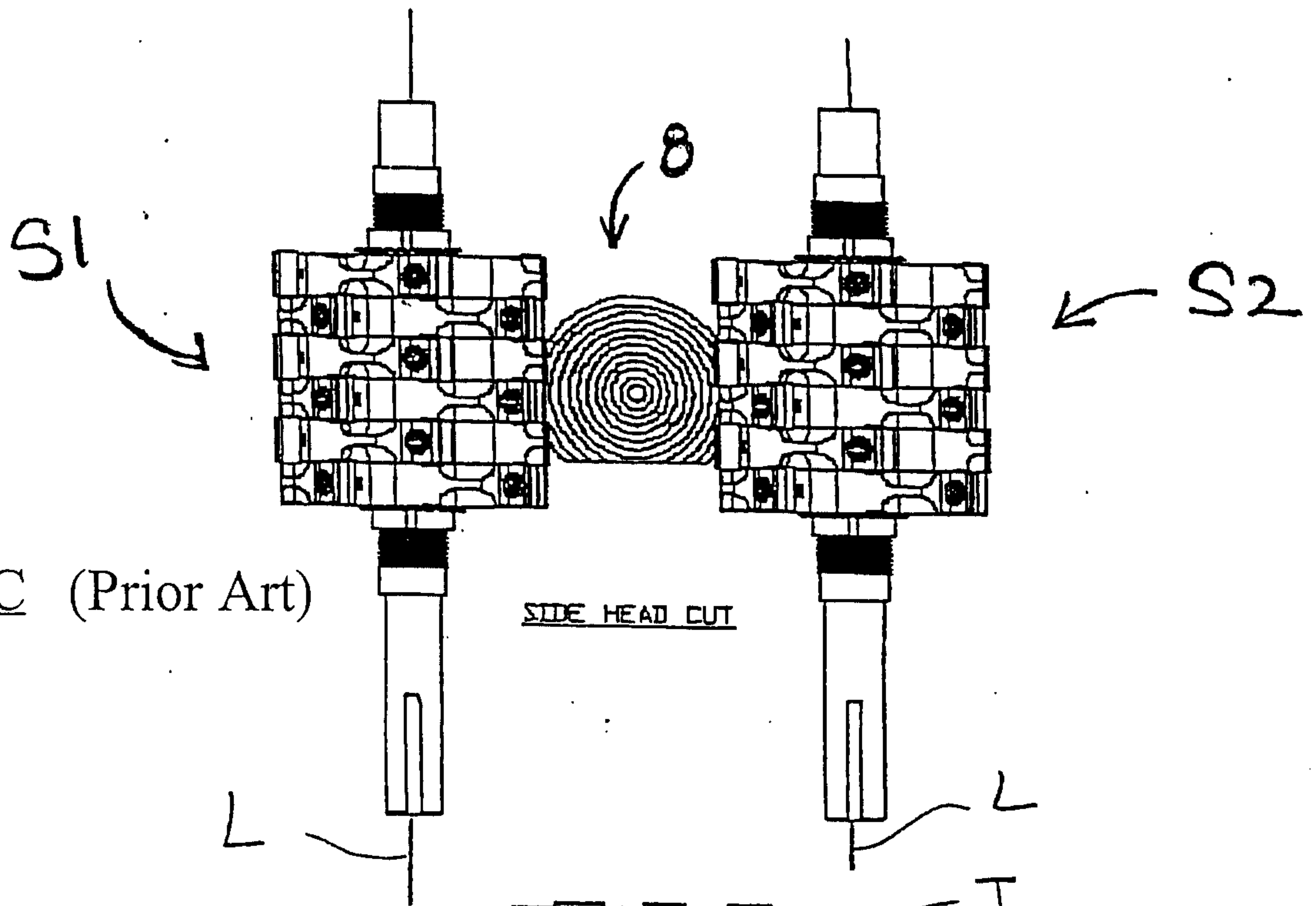

FIG. 2D (Prior Art)

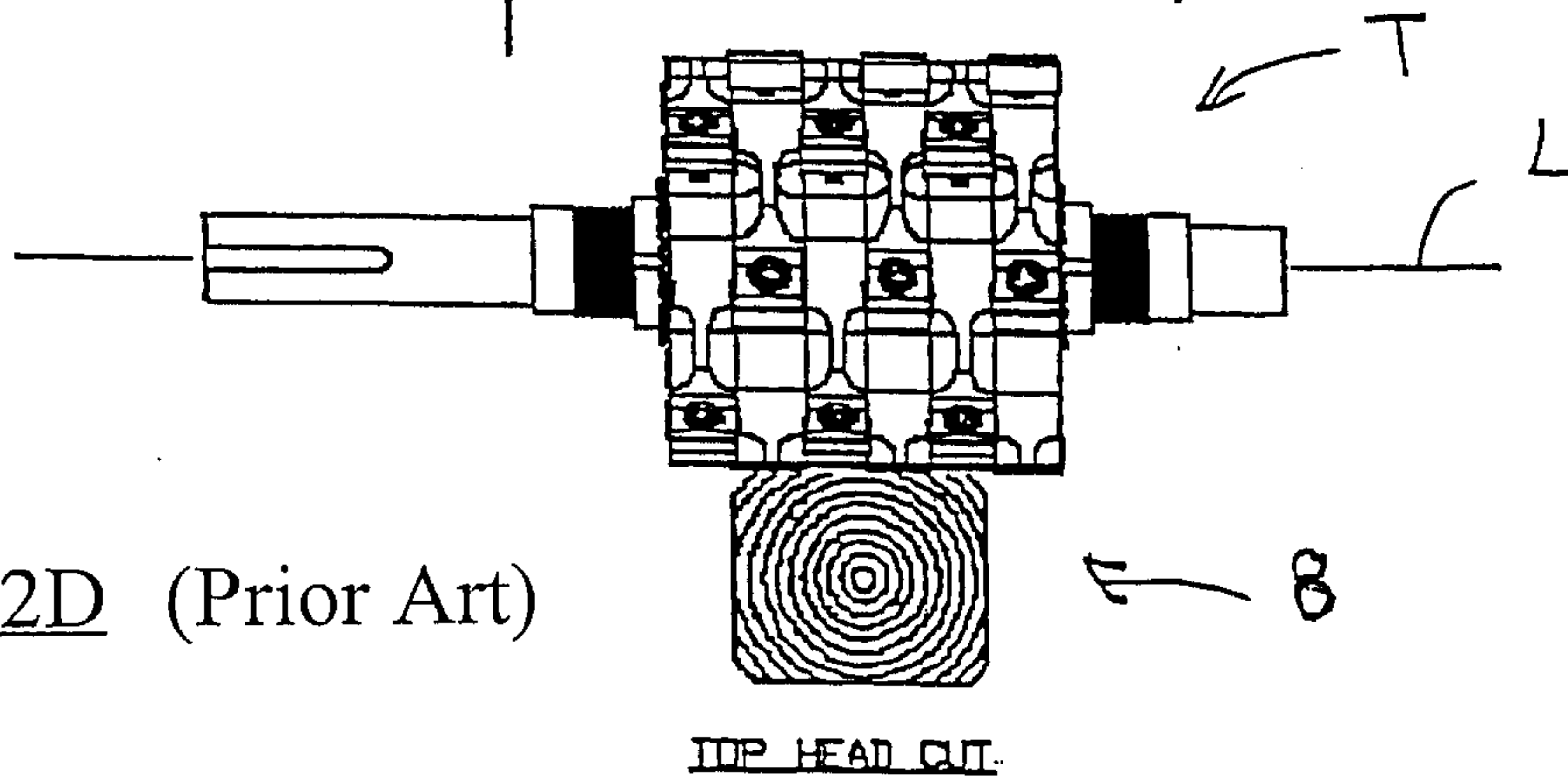
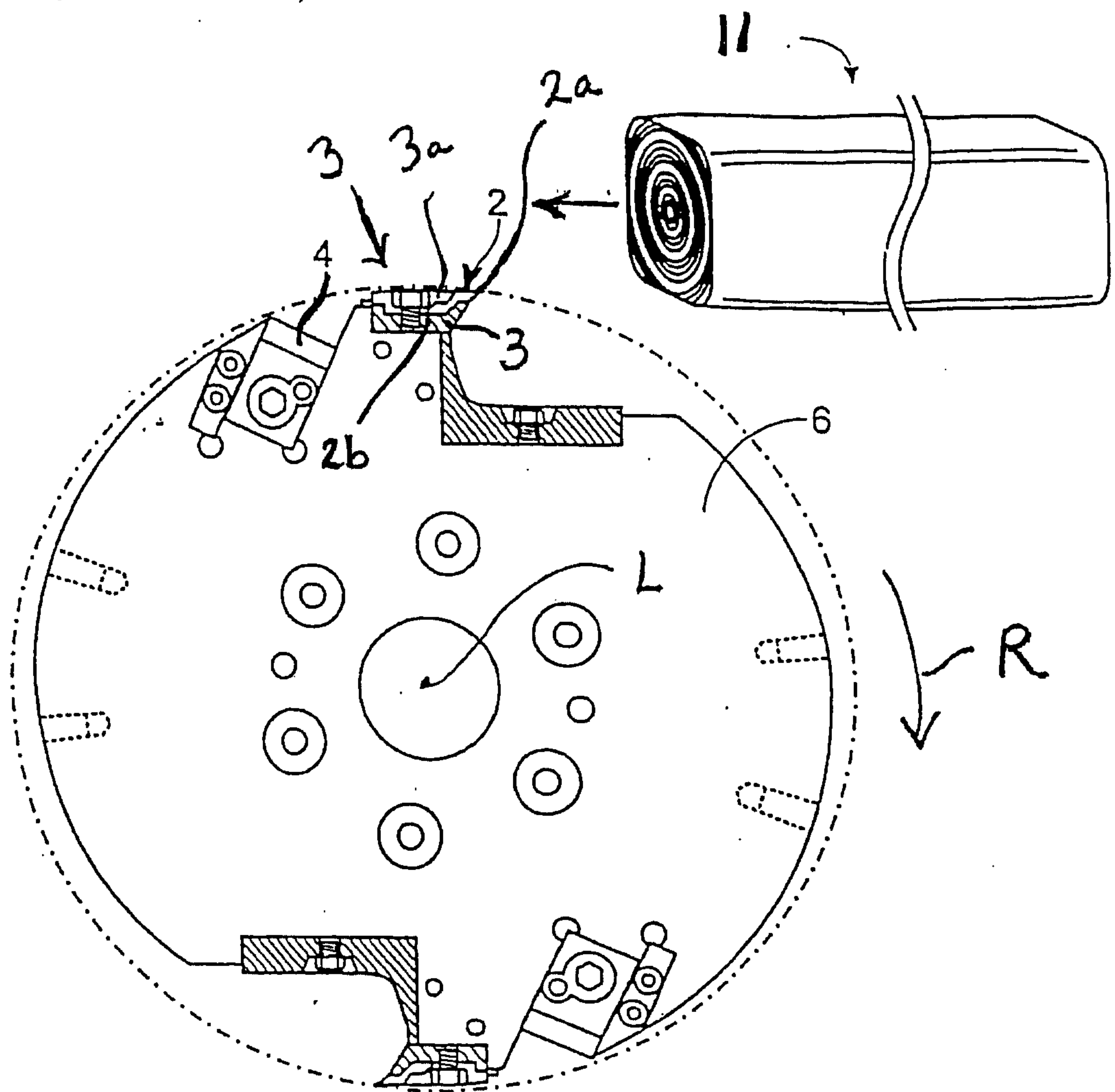

FIG. 3 (Prior Art)



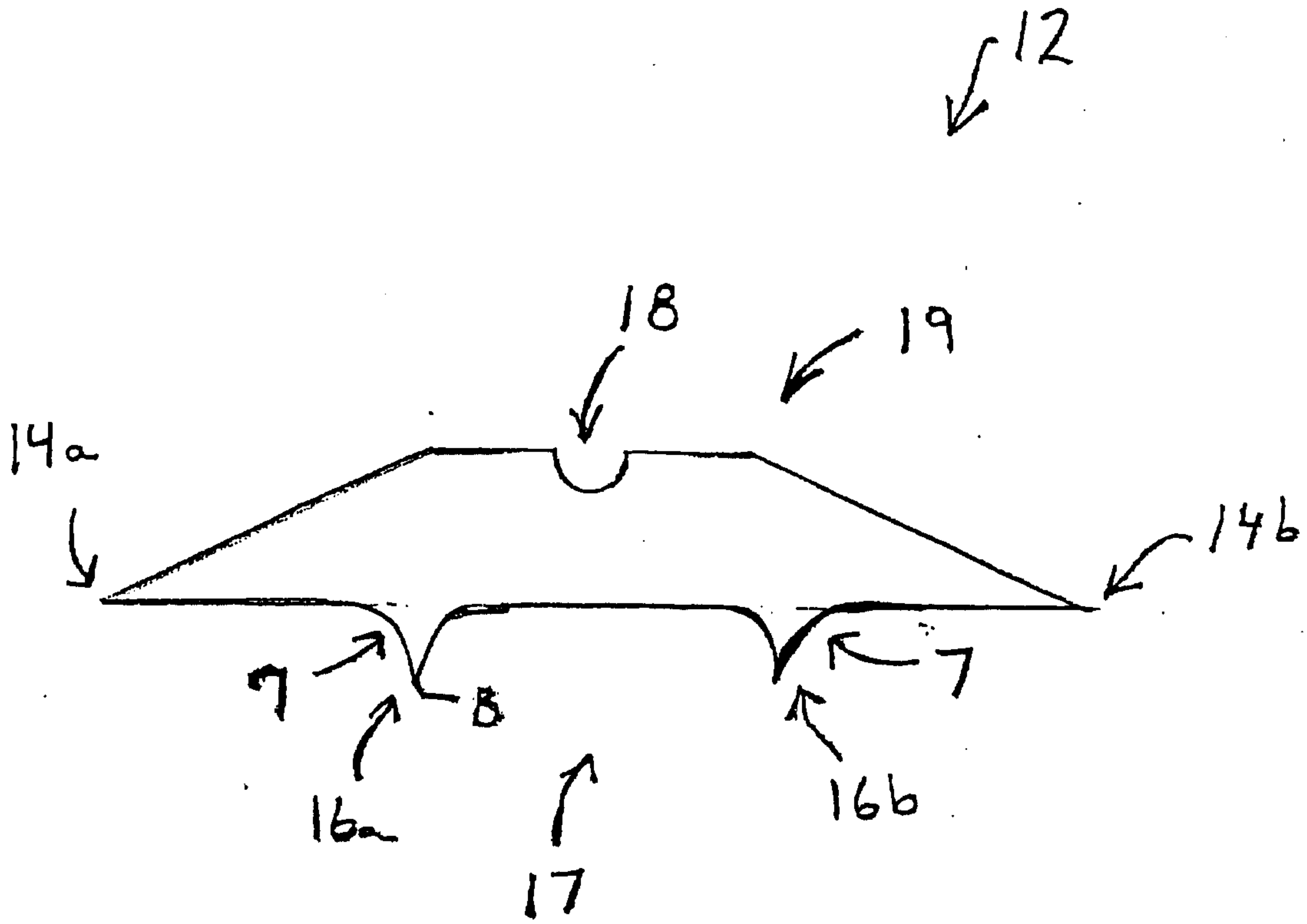

FIG. 4 (Prior Art)

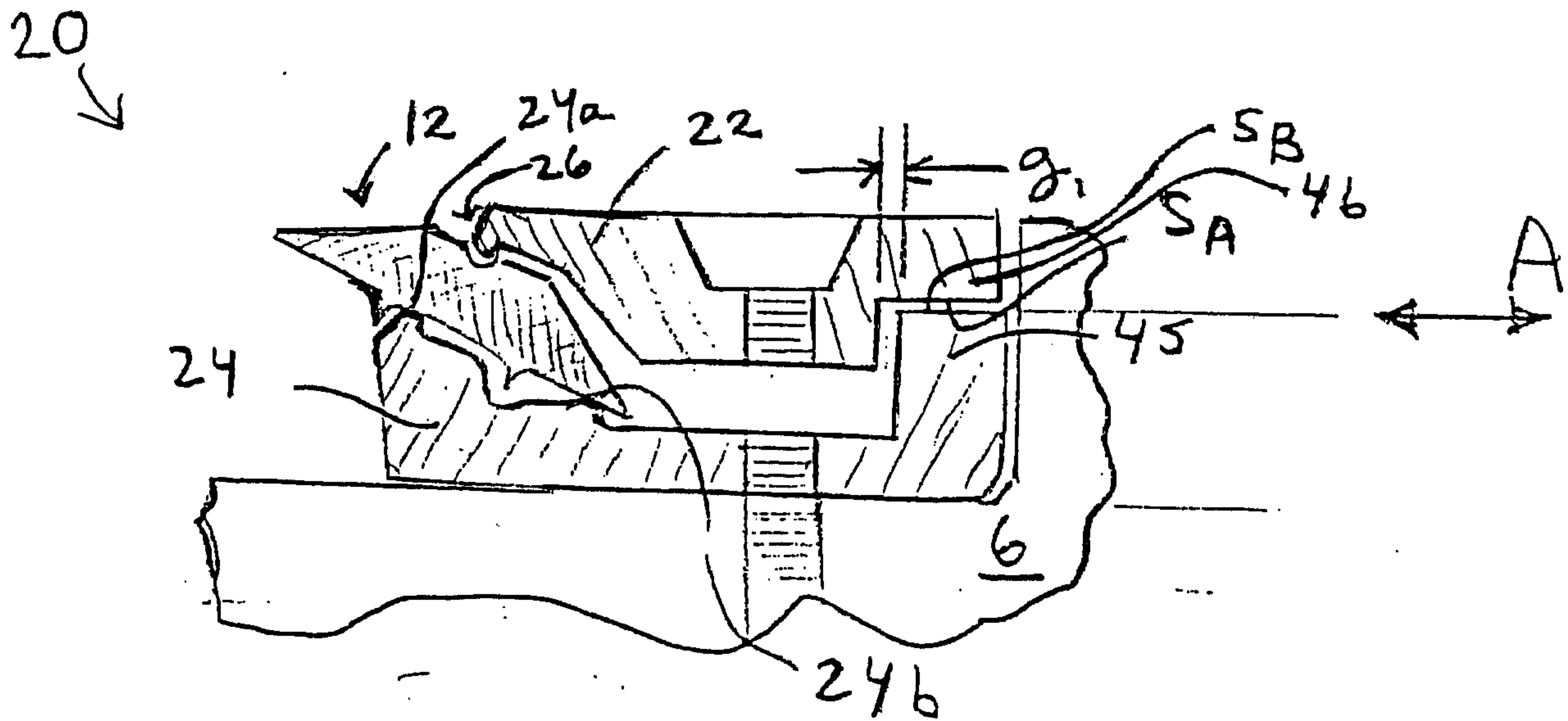

FIG. 5 (Prior Art)

33
↙

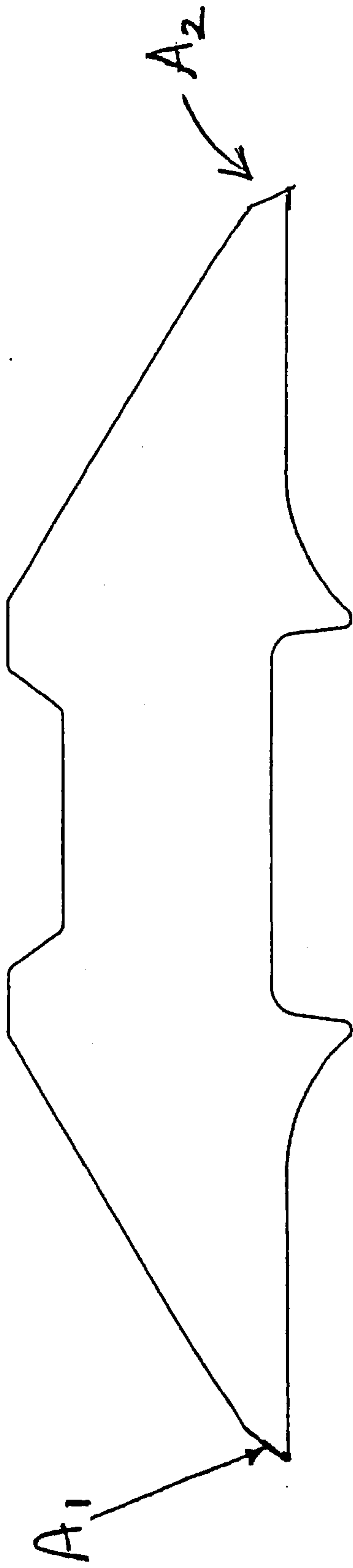

FIG 7

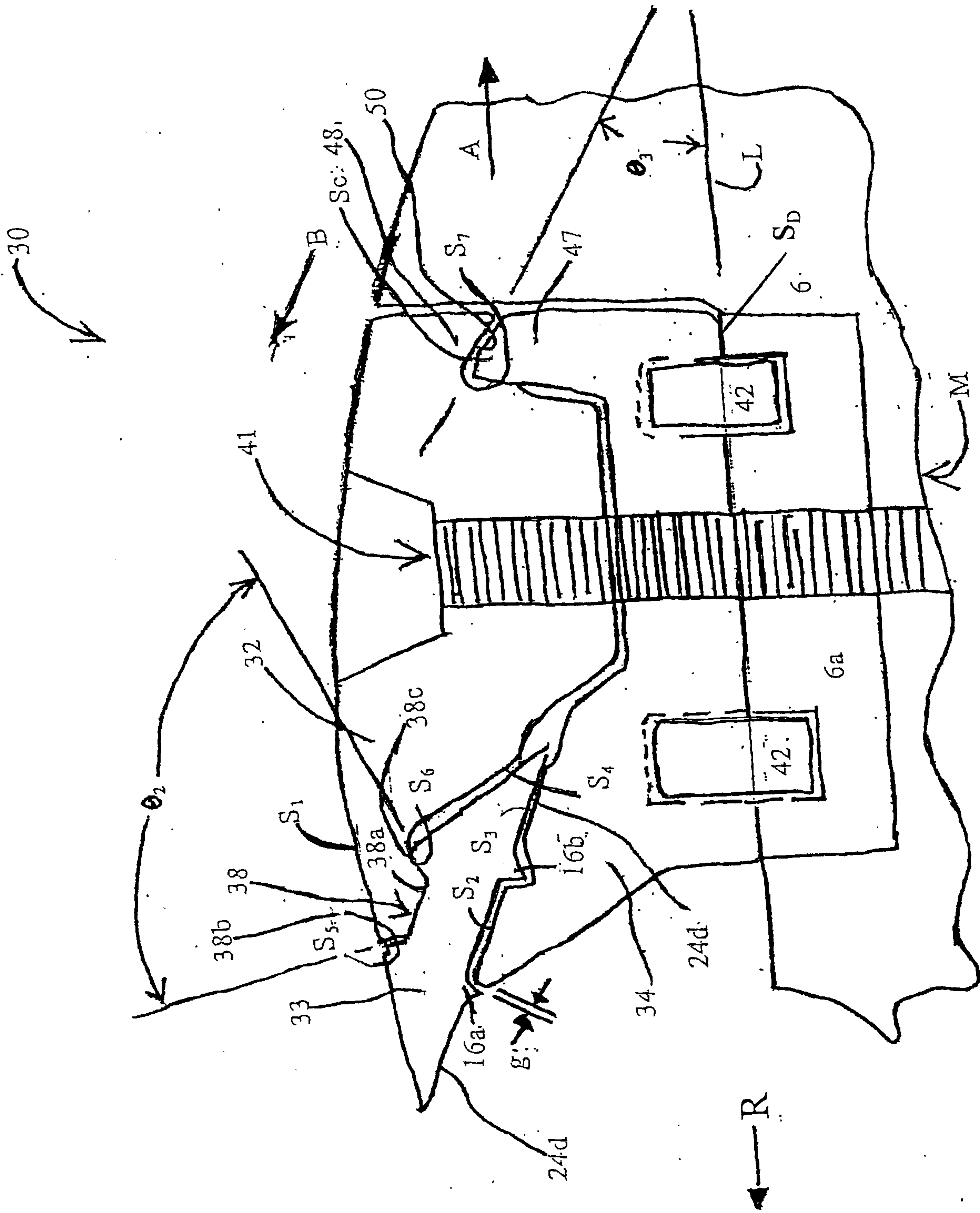

FIG. 8

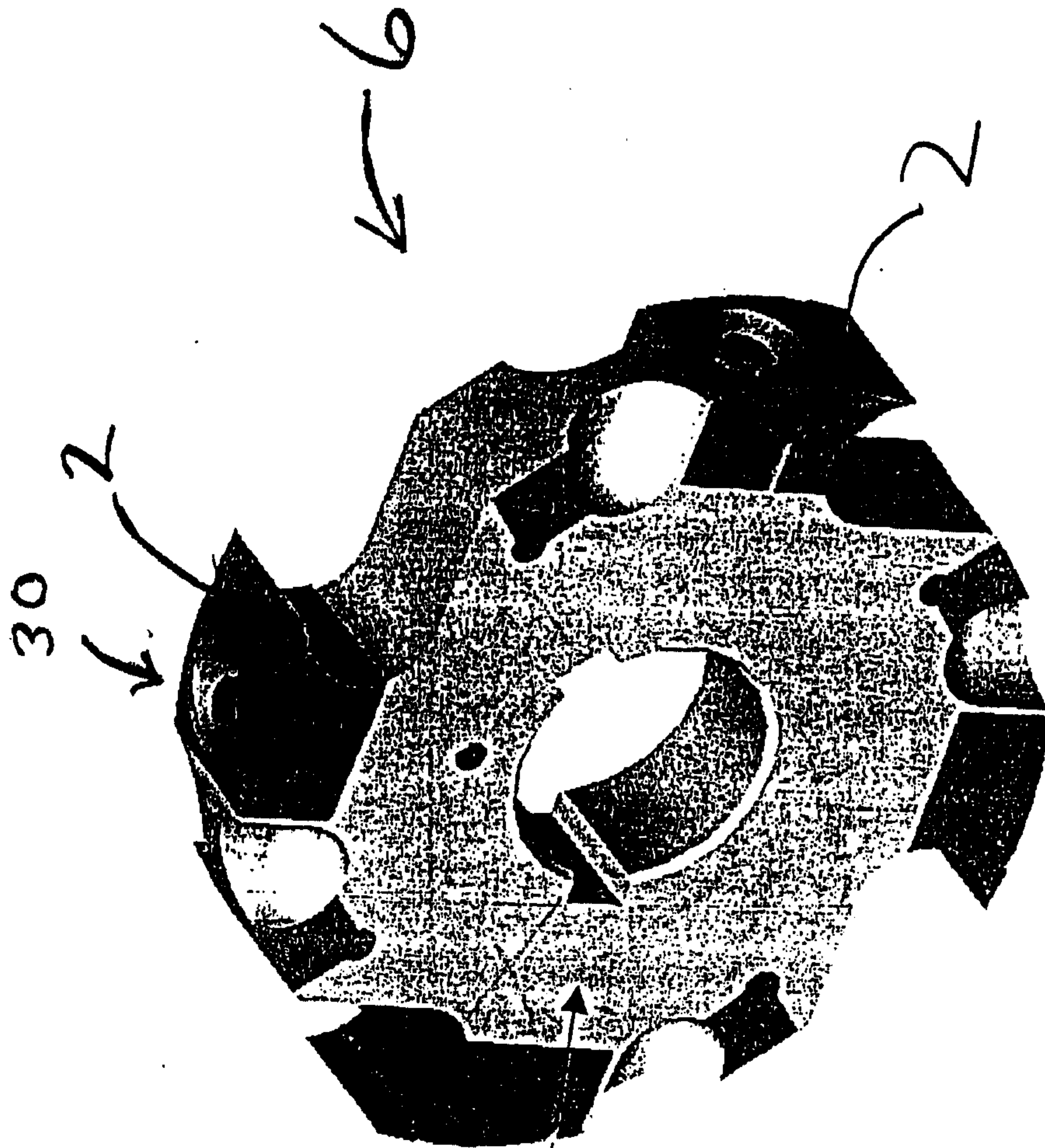

FIG 9

50 ↘

FIG 10

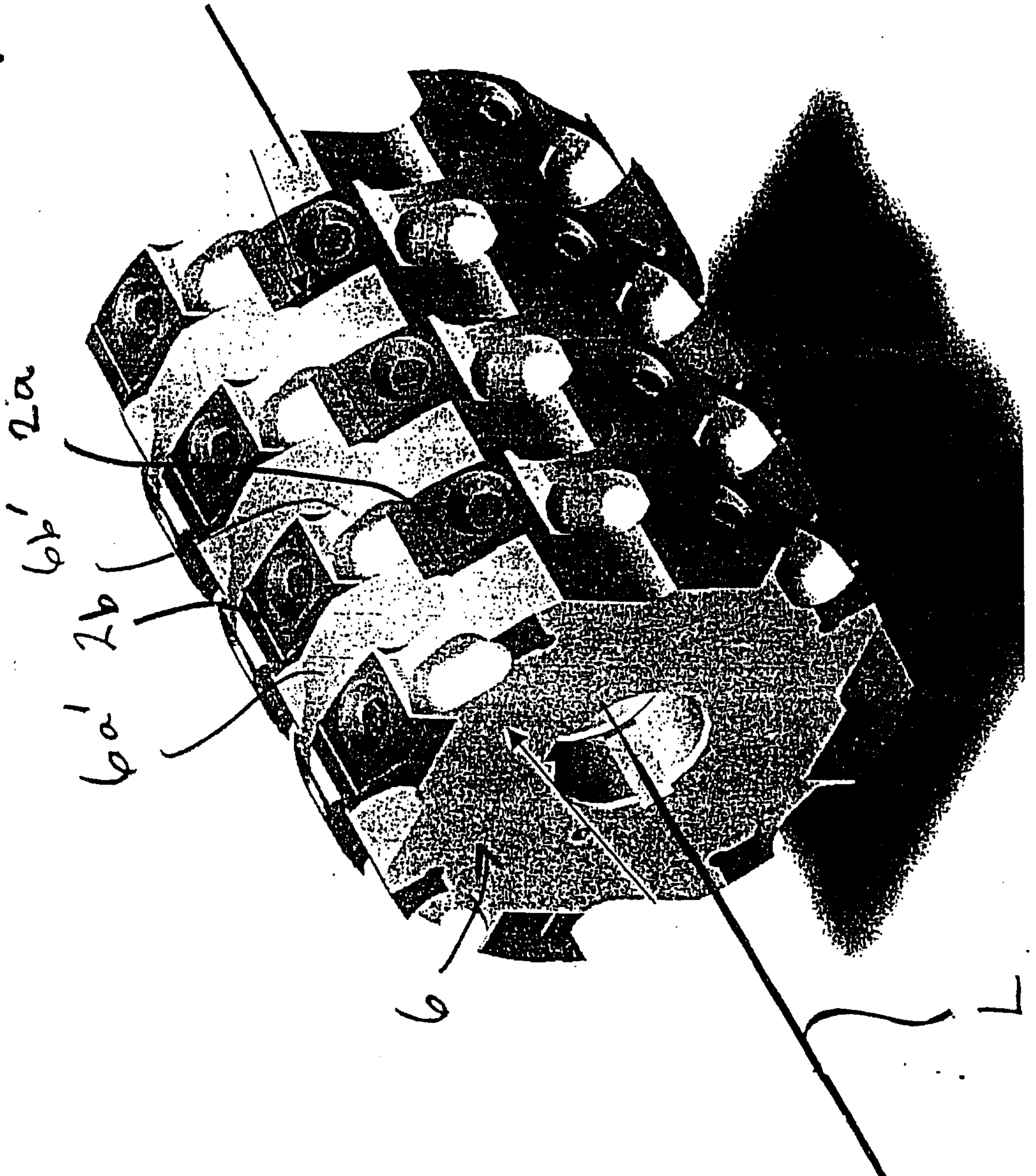
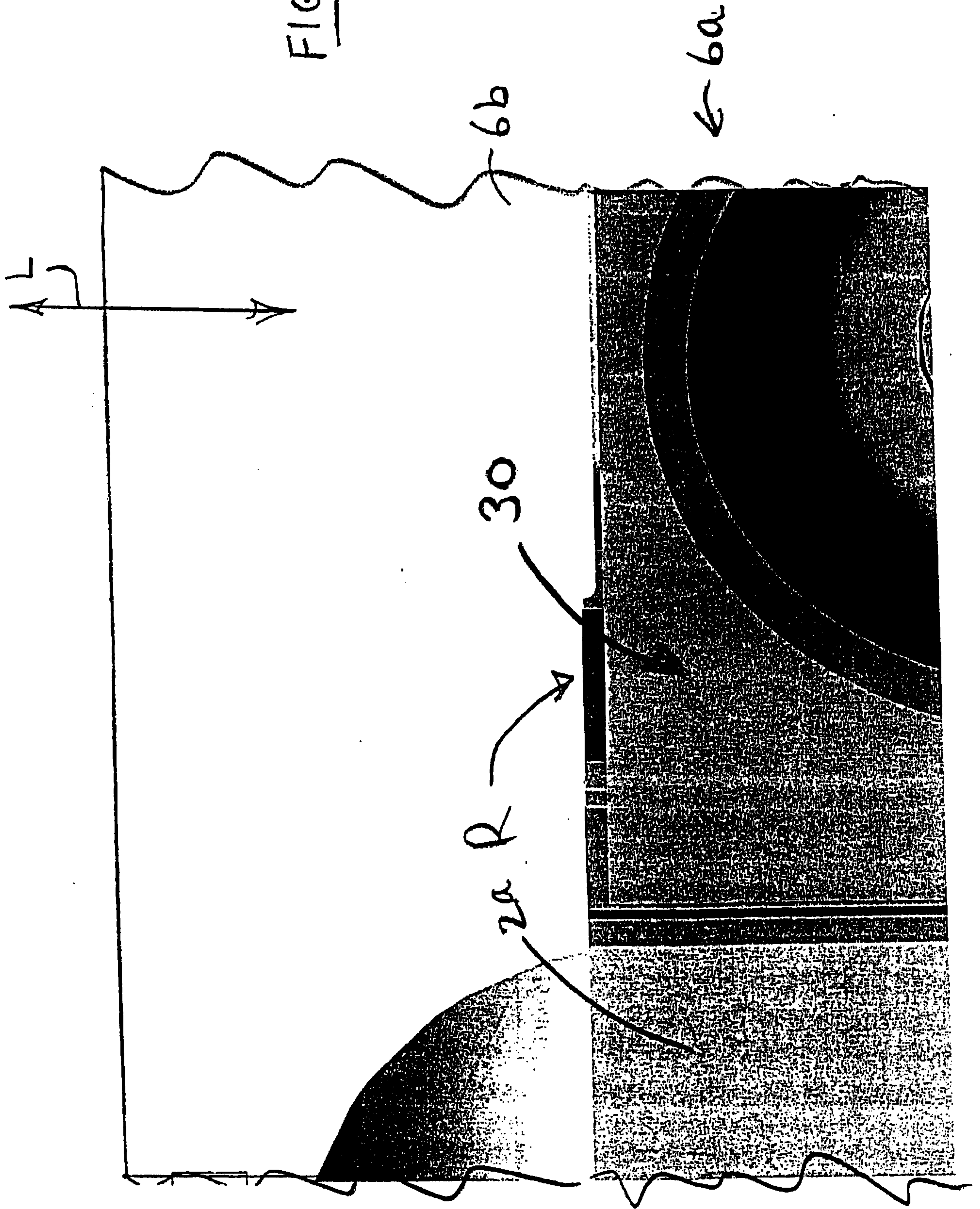

FIG 14



30

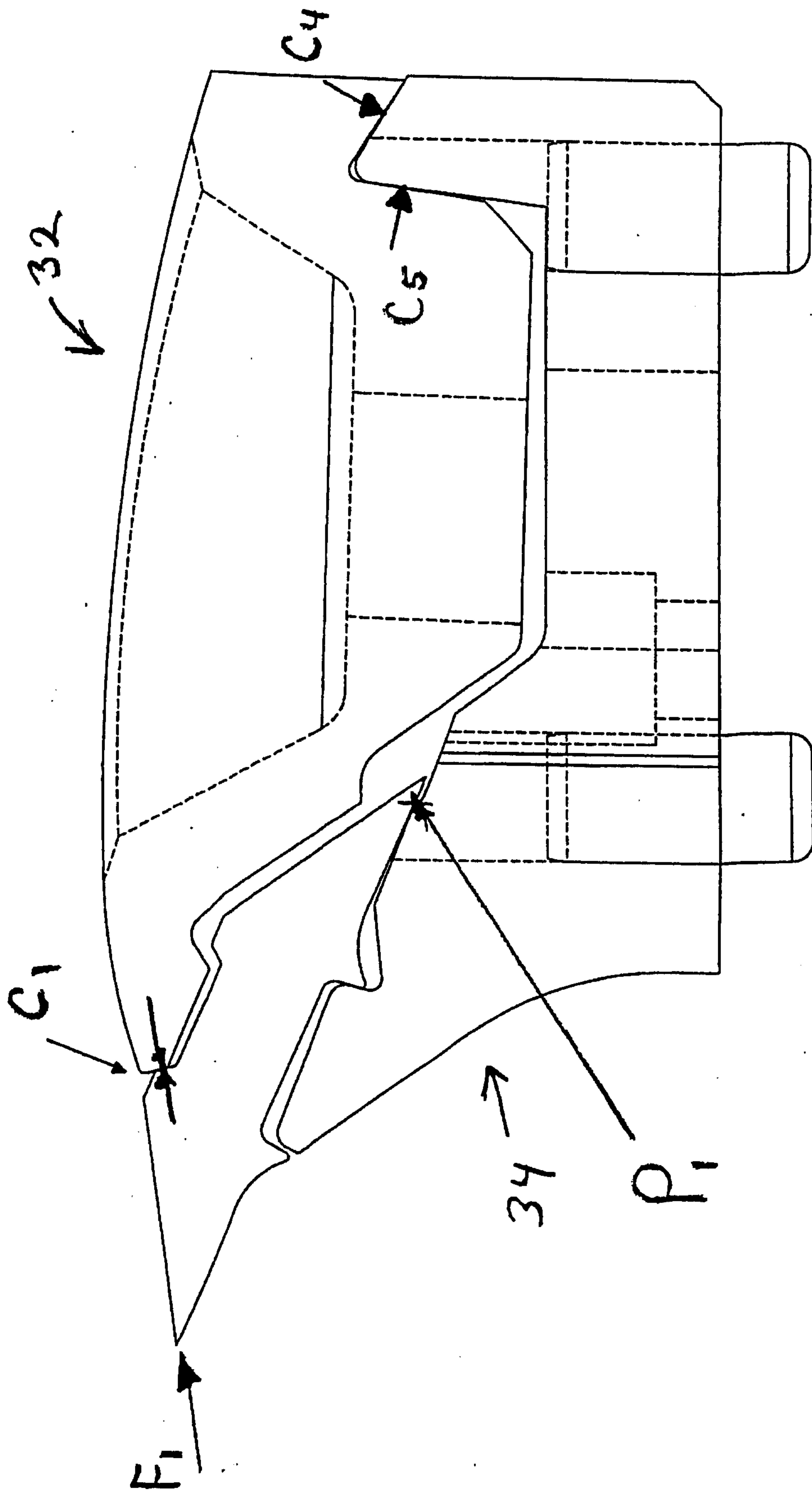

FIG 12

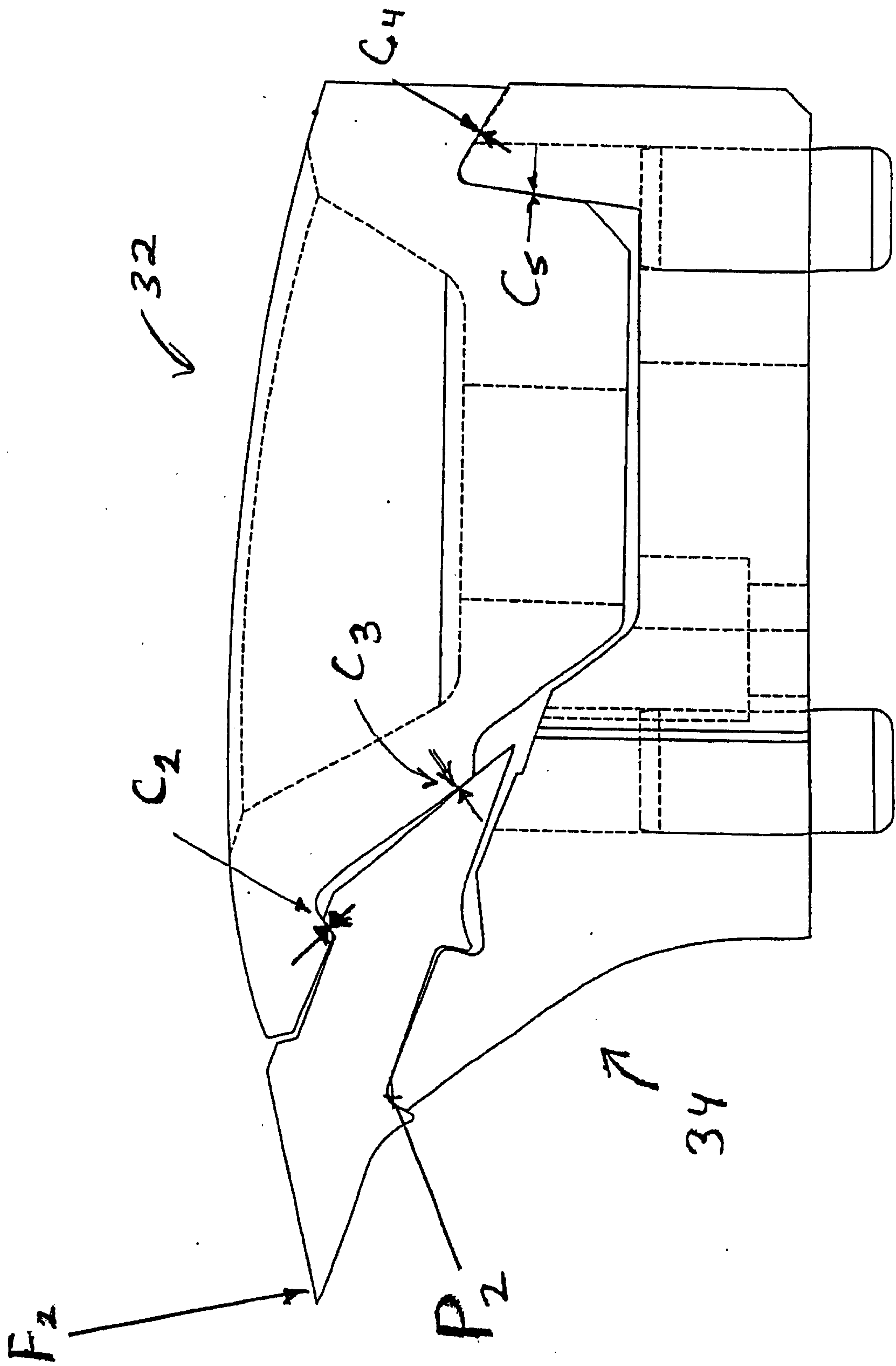

FIG 13

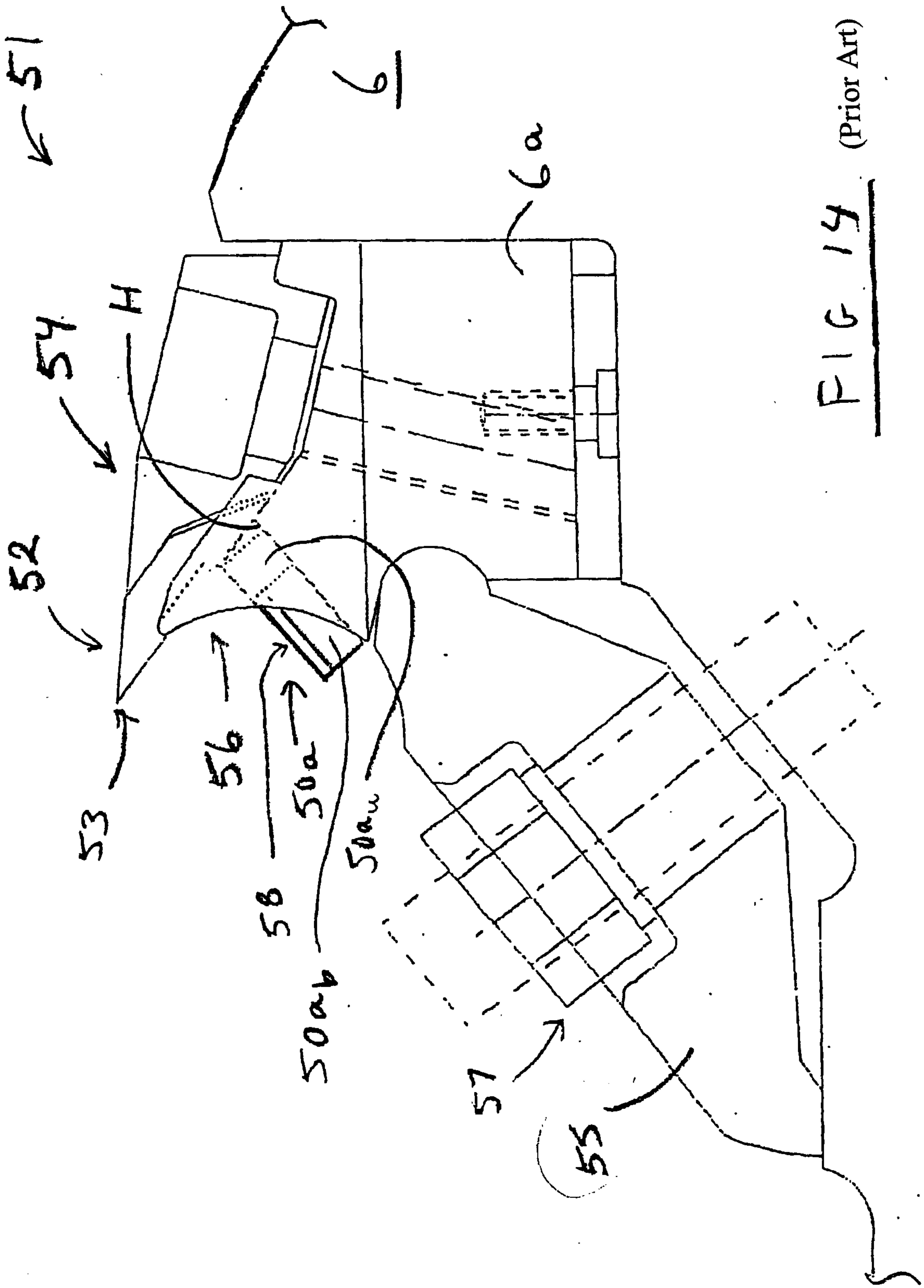

FIG 14 (Prior Art)

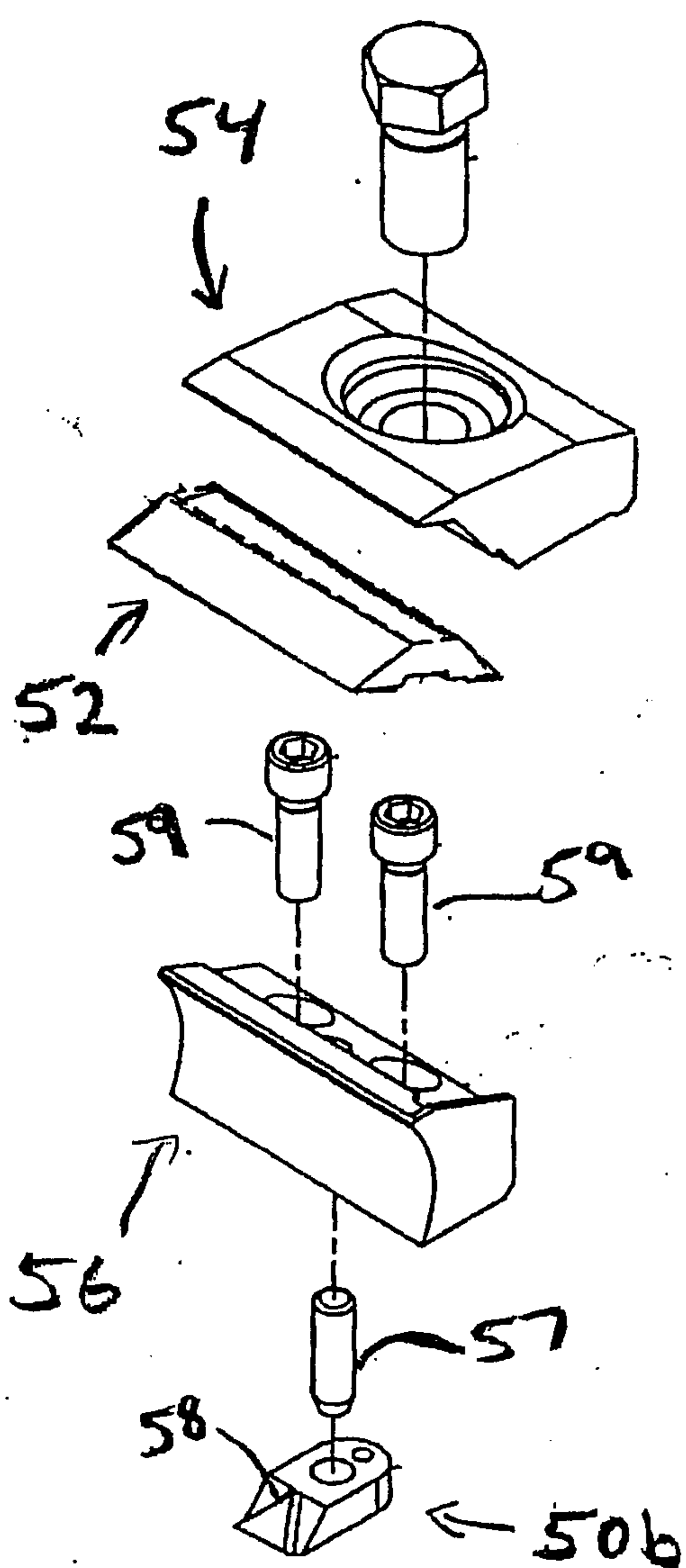

FIG 16

(Prior Art)

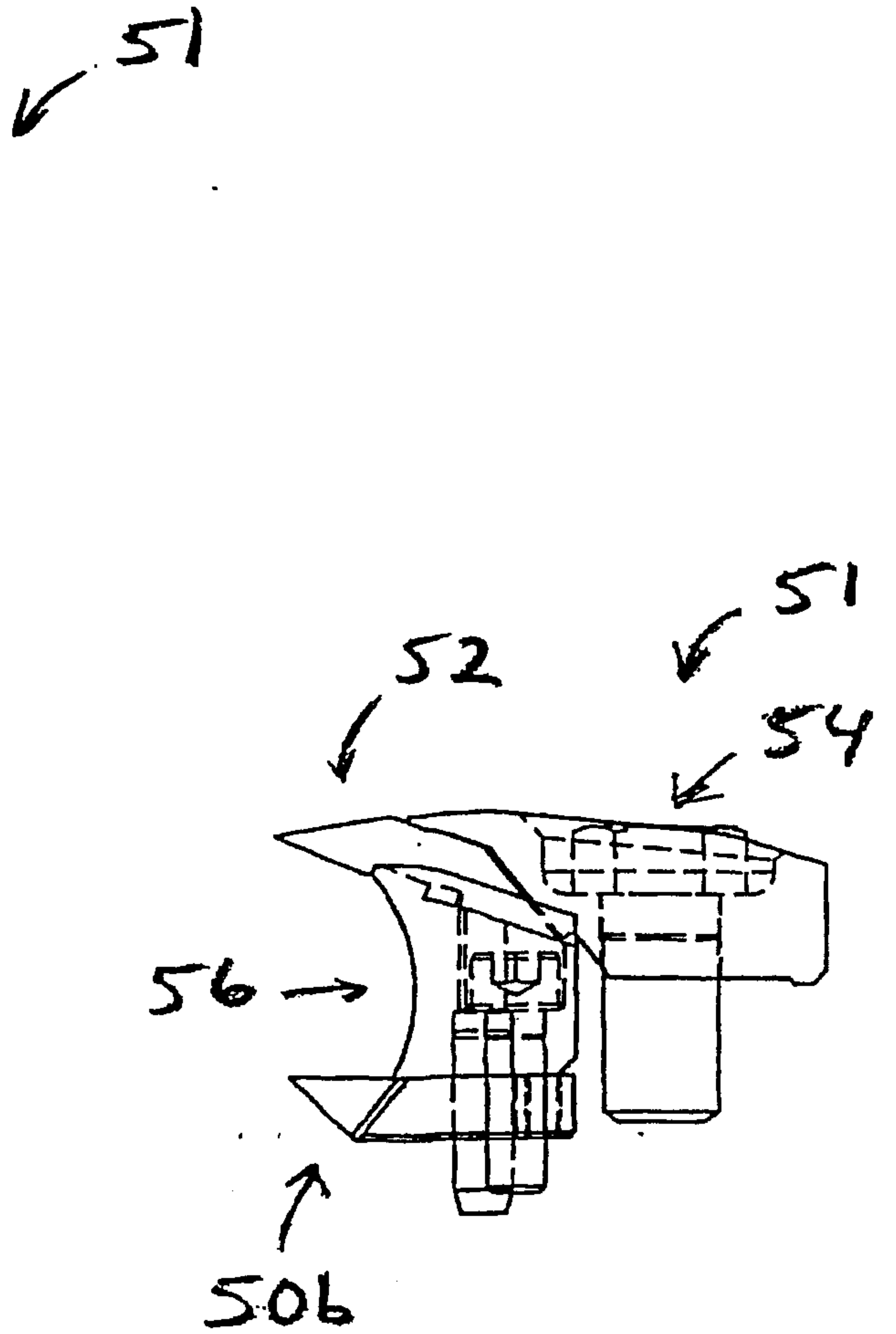

FIG 15

(Prior Art)

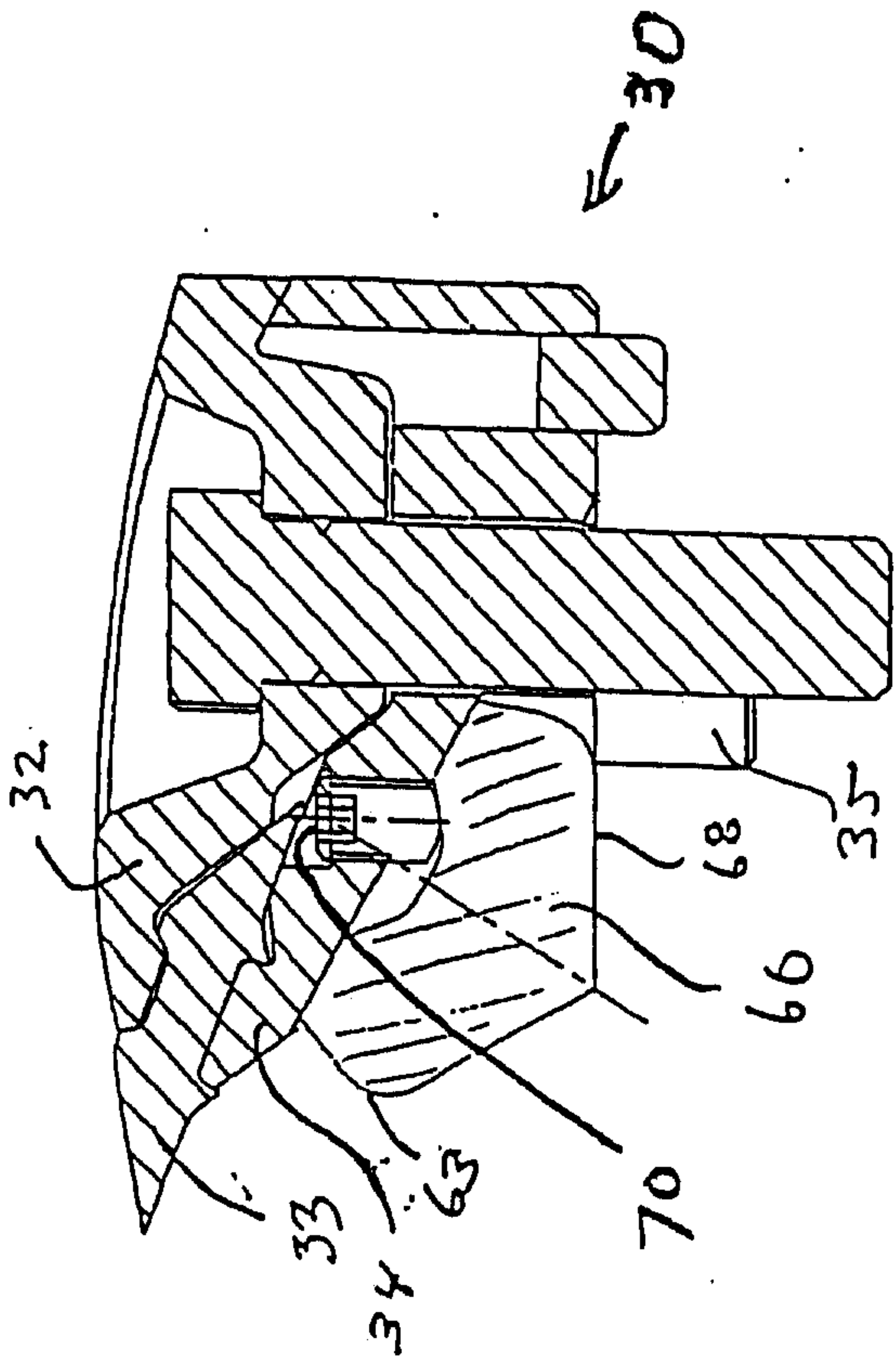

FIG. 20

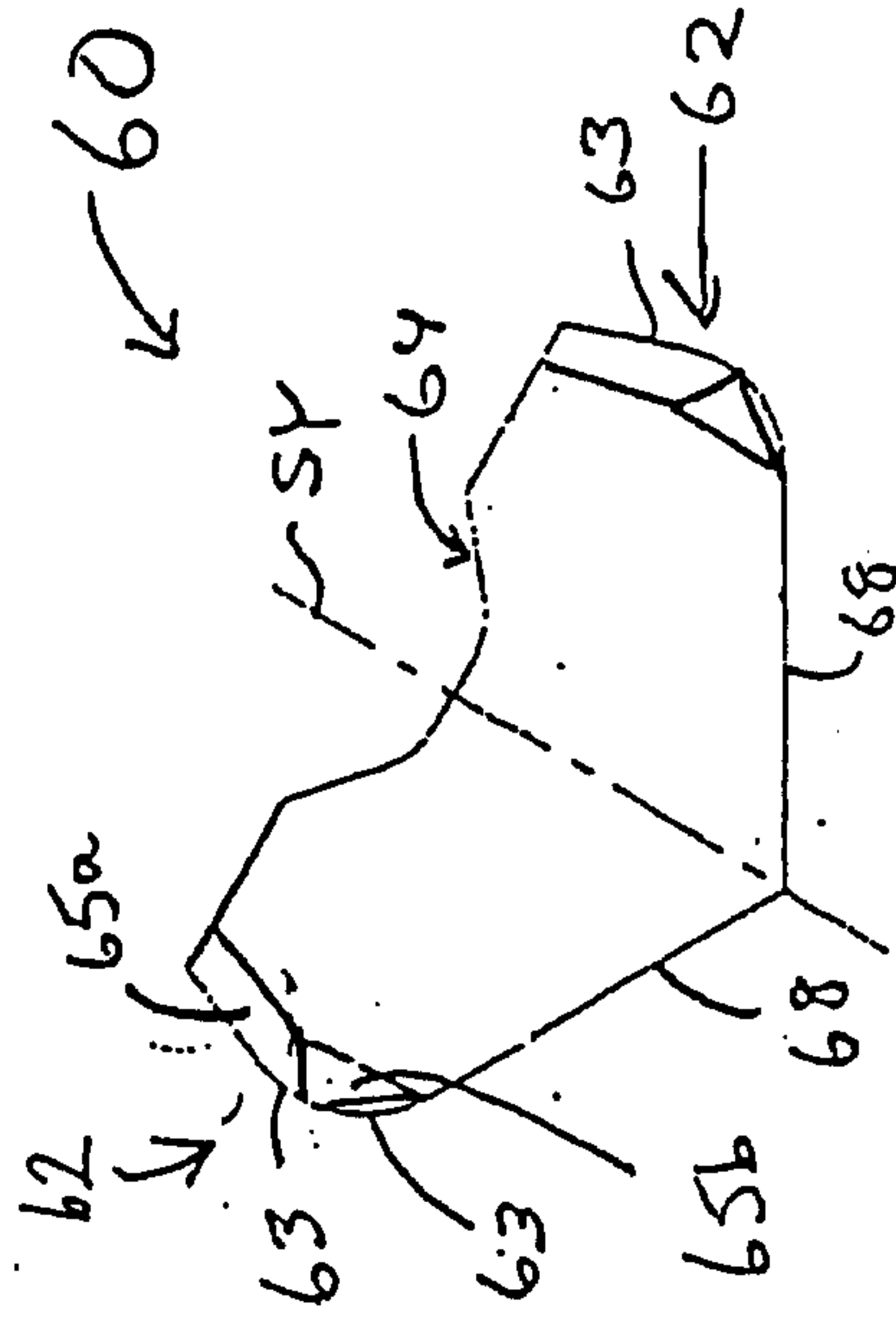

FIG. 17

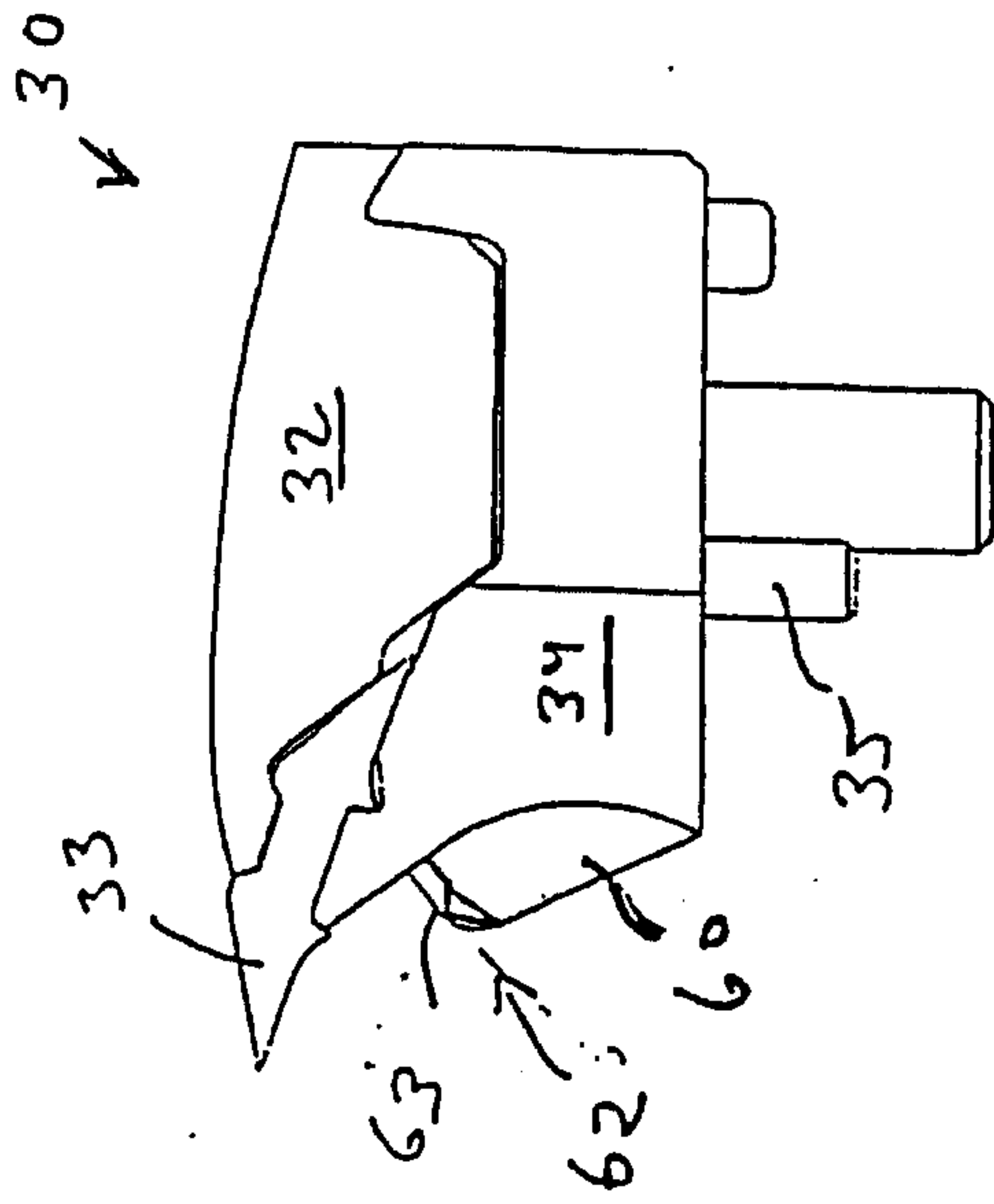

FIG. 18

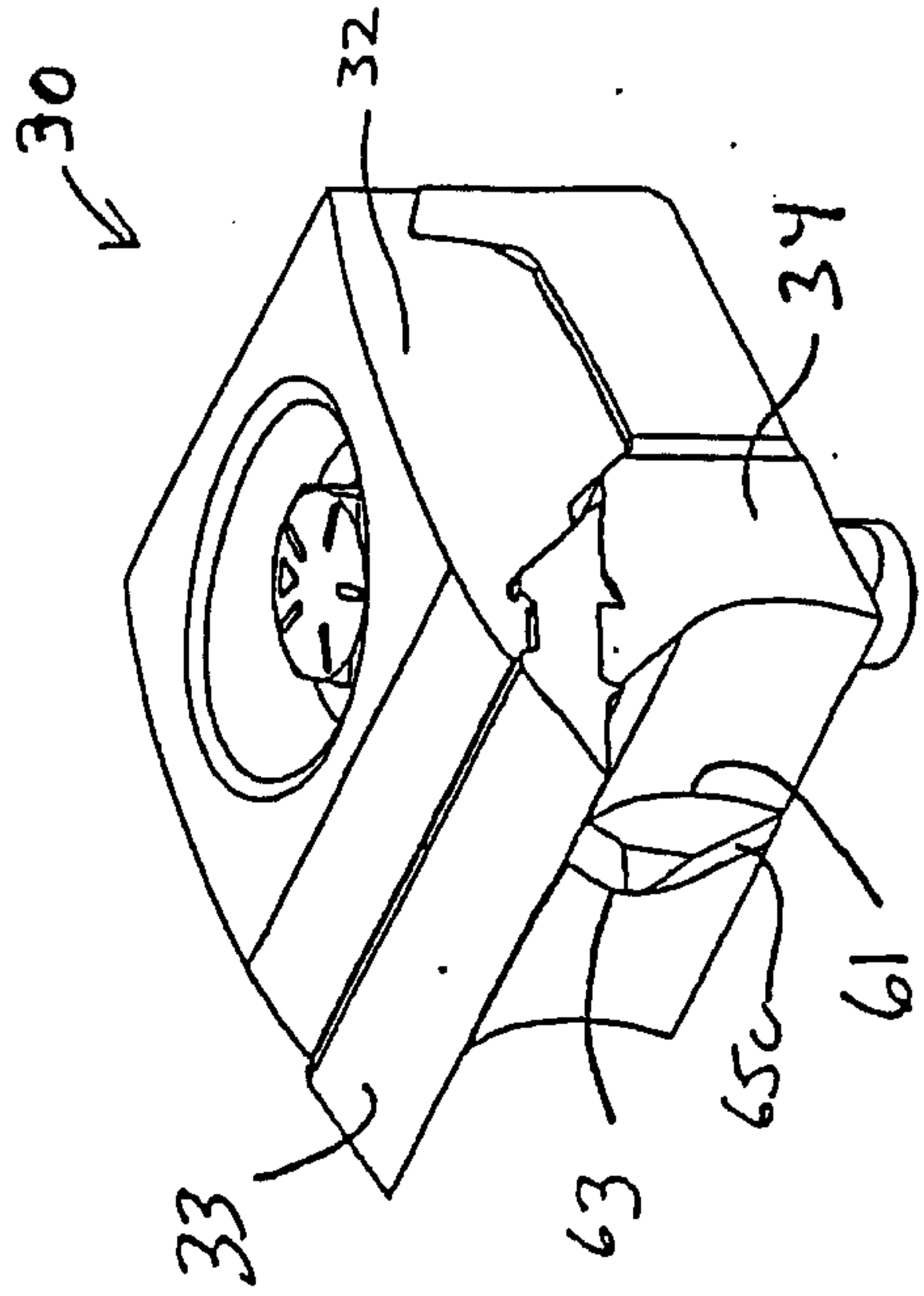

FIG. 19

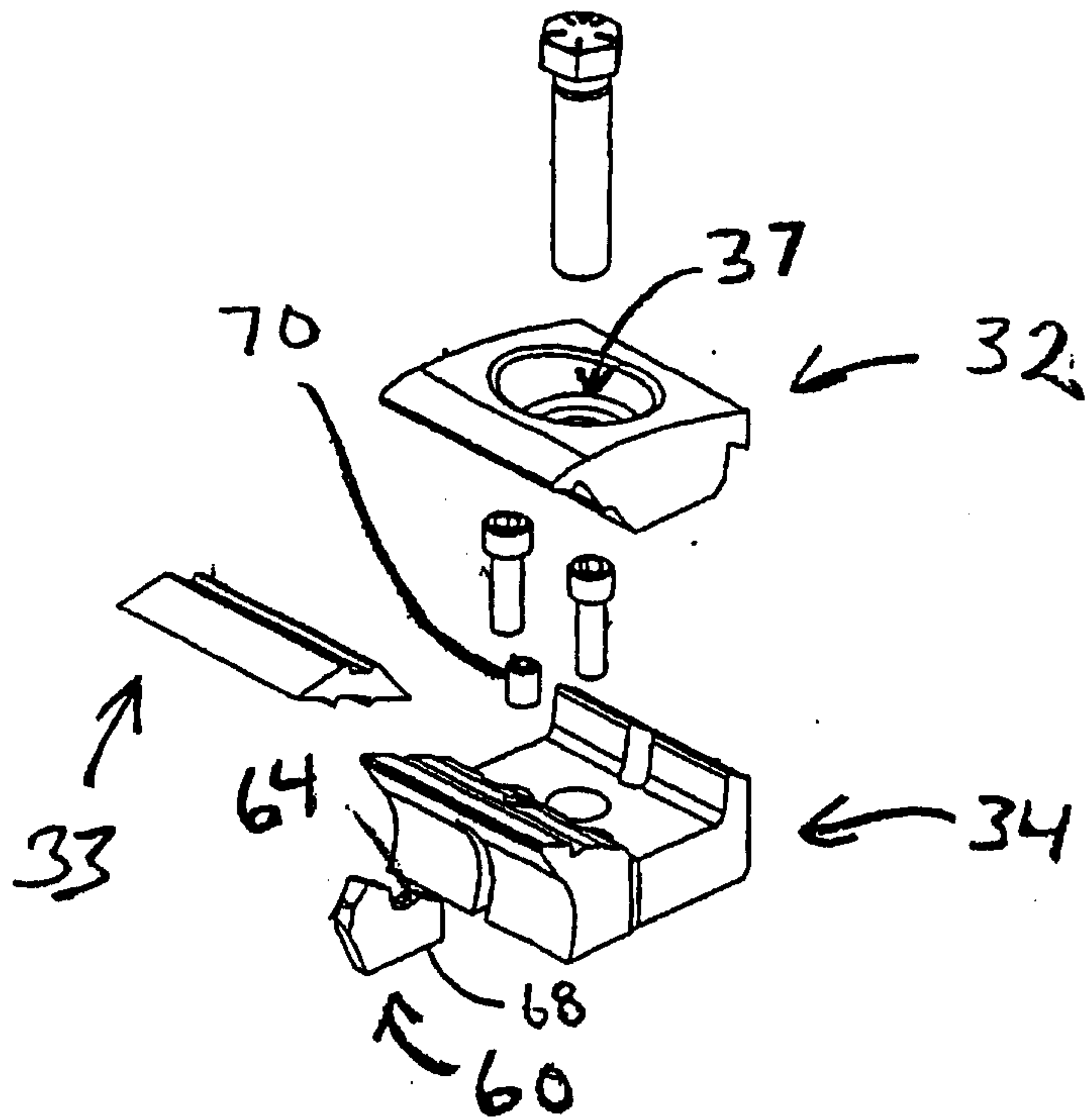

FIG 21

