

J. O. TONKIN.  
 RECORDING SPEED INDICATOR.  
 APPLICATION FILED MAR. 23, 1910.

998,213.

Patented July 18, 1911.

2 SHEETS-SHEET 1.

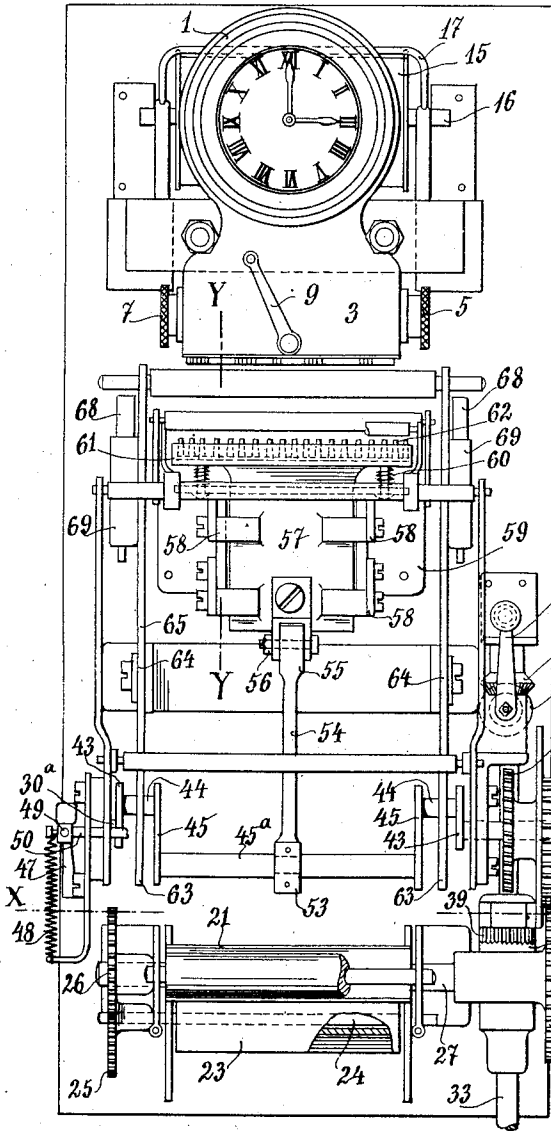

FIG. 1.

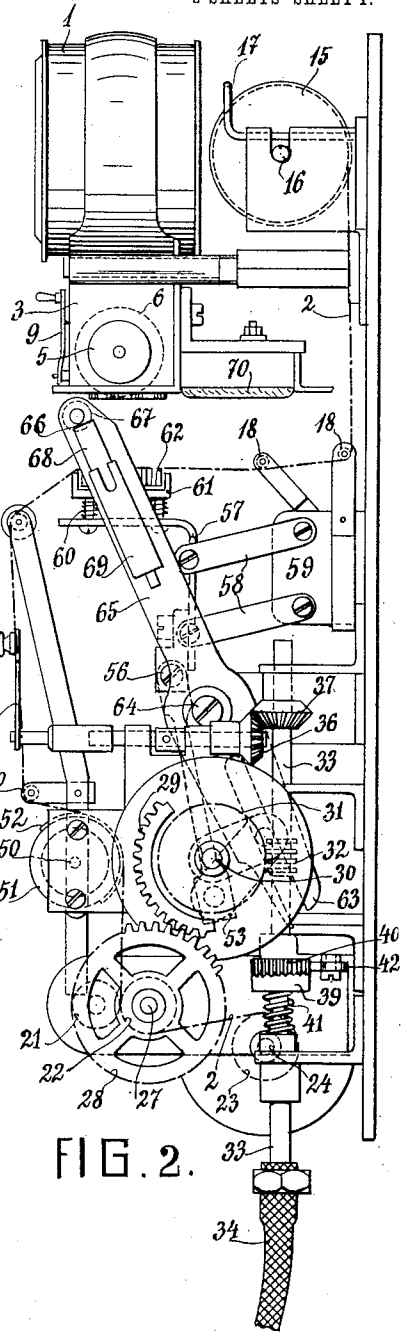

FIG. 2.

WITNESSES

*W. P. Burke*  
*John C. Sanders*

INVENTOR

*John Osborn Tonkin*  
 BY *Wm Wallau White*

ATTX

J. O. TONKIN.  
 RECORDING SPEED INDICATOR.  
 APPLICATION FILED MAR. 23, 1910.

998,213.

Patented July 18, 1911.

2 SHEETS—SHEET 2.

FIG. 3.

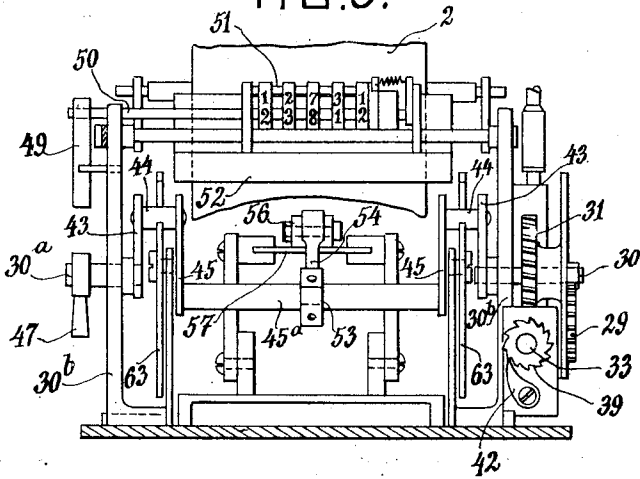

FIG. 4.

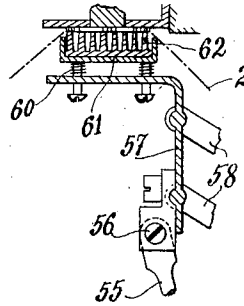

FIG. 5.

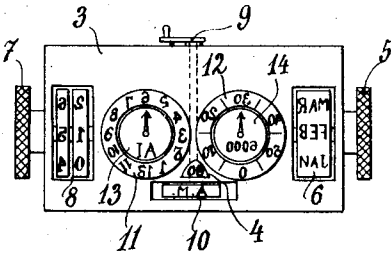

FIG. 6.

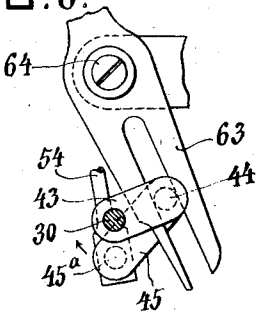
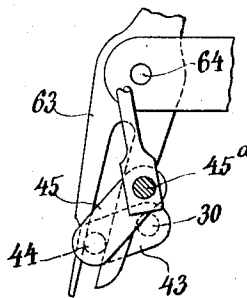

FIG. 7.



WITNESSES

W. P. Burk  
 John C. Sanders

INVENTOR

John Osborn Tonkin  
 BY Wm Wallace White

ALL Y.

# UNITED STATES PATENT OFFICE.

JOHN OSBORN TONKIN, OF STEGLITZ, NEAR BERLIN, GERMANY.

## RECORDING SPEED-INDICATOR.

998,213.

Specification of Letters Patent. Patented July 18, 1911.

Application filed March 23, 1910. Serial No. 551,075.

*To all whom it may concern:*

Be it known that I, JOHN OSBORN TONKIN, subject of the King of Great Britain, residing at No. 17 Elisenstrasse, Steglitz, near Berlin, Germany, have invented new and useful Improvements in Recording Speed-Indicators, of which the following is a specification.

This invention relates to recording speed indicators especially suitable for motor cars and other vehicles but also applicable to other machinery and refers to improvements in that type of indicators in which clock-work mechanism is provided actuating devices such as rubber type in combination with mechanism operated periodically during the travel of the vehicle, which mechanism is adapted to roll off a paper strip and to bring it into a position in which the rubber type prints an indication of the time whenever the vehicle has passed over a certain distance.

My invention relates to improvements in indicators of the foregoing type in which the construction is so modified and improved that the device is enabled to withstand the jolting and shocks to which it has to be subjected when attached to motor cars and other vehicles traveling over rough roads or at a high speed.

According to my present invention a doubly cranked shaft of special construction is utilized for giving movement to a pad for pressing the paper strip against the stamping apparatus and also for communicating movement to an inking roller for inking the type. In carrying out the invention I utilize a pad consisting of a plate, preferably provided on the surface with a number of pin shaped rubber buffers, and connected with a supporting plate on which it is yieldingly mounted. The driving mechanism which actuates the aforesaid double cranked shaft is also in positive connection with a toothed segment which communicates an intermittent movement to a pair of delivery rollers for feeding the paper strip.

In connection with the clock controlled time stamp which is of ordinary construction adapted to indicate hours and minutes I prefer to provide an indication mark which identifies the apparatus making the record or in other words identifies the particular car using the strip. Other particulars such as the driver's name may be added.

The invention is shown by way of example in the accompanying drawings.

Figure 1 is a front elevation, with some of the mechanism removed. Fig. 2 is a side elevation. Fig. 3 is a cross section according to lines and arrows X, X Fig. 1. Fig. 4 is a cross section according to lines and arrows Y, Y on Fig. 1. Fig. 5 is a somewhat enlarged plan view of the stamping apparatus. Figs. 6 and 7 are details hereinafter referred to.

The whole apparatus is inclosed by a case (not shown) which by means of openings adapted to be covered, enables the dial plate of the clock (1, Fig. 1) and the recording strip to be read and the latter to be written upon.

There is secured to the clock 1, the stamping apparatus 3, the type portions of which comprise the following:—(see Fig. 5). A changeable year stamp 4, a month wheel 6 adapted to rotate with a hand wheel 5 on its axis, a pair of day wheels 8 adapted to rotate with a hand wheel 7 on its axis, a forenoon and afternoon wheel 10 adapted to rotate with a hand wheel 9 on its axis, an hour and a minute dial plate (11 and 12 respectively) having rotatable middle plates 13 and 14, which are synchronous with the hour and minute hands of the clock 1; they are driven by the latter and their hour and minute hands are provided with marks (A 1 and 6000 respectively) for identifying the vehicle.

15 is a roller for the reception of the recording strip 2. The pivots 16 of this roller are held in position by a holder 17 to admit of the removal of the roller 15 for its replacement by a new one.

18, 18, 19 and 20 are fixed rollers over which the strip passes and 21 and 22 are a pair of feeding rollers and 23 is a winding roller which is adapted to rotate frictionally on its axis 24 so as to conform with the peripheral speed according to the increasing diameter of the wound recording strip. All the rollers 18 to 24 are supported in suitable bearings attached to the casing.

25 is a toothed wheel on the axle 24 see Fig. 1. This engages with a toothed wheel 26 on the lower feeding roller 22.

28 is a toothed wheel mounted outside the bearing at the outer end of the roller 22 on the axle 27 which wheel 28 gears with a toothed segment 29, mounted on the surface

of a disk. The segment 29 is mounted upon an axle 30 which has also mounted thereon a worm wheel 31 gearing with a worm 32 on the driving shaft 33. The driving shaft 33 is adapted to be operated at the one end from the vehicle by means of a flexible shaft 34 and on the other end by means of a removable crank 35 and bevel gearing 36 and 37. The spring clutch 39 and 40 is provided in the length of the shaft 33, the part 39 being controlled by a spring 41 and the part 40 is peripherally indented and constrained to move in one direction only by the spring catch 42. By this means the speed indicator can only be operated in one direction that is only during the forward movement of the vehicle. The axle 30 and a similar axle 30<sup>a</sup> are mounted in bearings 30<sup>b</sup> on either side of the casing. Each of these has keyed to it a crank 43.

45 are arms connected to the crank pins 44. Each of the cranks 43 is provided with a crank pin 44 and between the arms 45 is a supplementary rotating crank pin 45<sup>a</sup>. The comparative length and relative angular setting of the cranks 43 and arms 45 are shown at Figs. 6 and 7, where Fig. 6 shows a view with the mechanism in the position shown at Figs. 1 and 2 taken from in front of the axle 30, and Fig. 7 is a view of the mechanism in its opposite extreme position taken through the supplementary crank pin 45<sup>a</sup>.

54 is a connecting rod one end of which 53 is mounted loosely on the supplementary crank pin 45<sup>a</sup> the other end 55 is pivotally and adjustably attached at 56 to a plate 57. This is adapted to move by guide rods.

58 are guide rods pivoted to a base plate 59 upon which the beforementioned guide rollers 18 are mounted.

The plate 57 is bent round at right angles and thus forms a supporting plate for a plate 61 provided with pin shaped rubber buffers 62.

60 are adjustable springs interposed between the plate 61 and the bent round portion of the plate 57. The rubber buffers 62 are so located as to come beneath the strip 2, see Fig. 2.

63 is a bifurcated arm the tines of which embrace the crank pins 44. The arm 63 is elongated into another arm 65 pivoted at 64 to a suitable bearing. Mounted in a slot 66 at the end of the arm 65 is an inking roller 67. The pivot of this roller bears loosely on a spring controlled sliding piece 68.

69 are guides on the arm 65 in which the piece 68 slides. This allows the inking roller 67 to take ink from the inking pad 70 secured to the stamping apparatus 3, and enables it to deliver ink to the type of the stamping apparatus 3 as indicated at Fig. 2.

47 is an arm mounted upon the spindle 30<sup>a</sup>.

50 is the spindle of the kilometer counter 51. Attached to the spindle 50 is an arm

49 controlled by a spring 48. The action of this portion of the mechanism is that every time the arm 47 passes the arm 49 which is kept in its path under the action of the spring, the kilometer counter is actuated.

52 is a semi-cylindrical guide partly surrounding the kilometer counter, over which the recording strip 2 passes from the roller 20 to the feeding rollers 21 and 22.

The general action of the mechanism will be easily understood:—Assuming that the paper strip roller is in position and that the strip 2 has been passed under the rollers 18, over the roller 19 around the roller 20, past the semi-circular guide 52 between the gripping rollers 21 and 22, and attached to the roller 23, and assuming that the parts are in the position shown at Figs. 1, 2 and 6, the flexible shaft 34 rotates owing to the movement of the vehicle, thus causing the worm 32 to rotate the worm wheel 31 thus rotating the shaft 30 and with it the toothed segment 29. This toothed segment (in the position shown at Fig. 1) being intergearing with the wheel 28 the gripping roller 22 and consequently the other gripping roller 21 are caused to turn, the strip 2 being wound upon the winding roller 23 by the action of the gear wheel 25. While this action is taking place the shaft 30 has turned which causes the cranks 43 and consequently the crank pins 44 to move around. The movement of the arm 63 causes the inking roller 67 to be drawn toward the pad 70. The rotation of the crank 43 also causes the supplementary crank pin 45<sup>a</sup> and the arms 45 to rotate, whence through the intermediary of the rod 54 the pad 62 is gradually forced upward carrying with it the strip 2. The upward movement causes the paper strip to unroll from the bobbin 15 the gripping rollers 21 and 22 preventing any return movement, and the printing is satisfactorily effected owing to the rubber buffers 62 controlled by the springs 60 pressing on the underside of the paper, the front of the strip being pressed in contact with the stamp. This position is shown in section at Fig. 4. The apparatus then returns to its former position as the vehicle continues to travel.

When it is desired to turn the strip 2 irrespective of the travel of the vehicle it is simply necessary to turn the handle 35 which rolls a portion of the strip off the bobbin 15, the teeth of the clutch 39, 40 slipping over one another during this operation.

It will be observed that the construction and position of the parts are such that when the pad 62 is rising and when it is in its upward position, *i. e.* in the printing position, the toothed segment 29 is out of gear with the wheel 28, but when the printing has taken place the toothed segment 29 has been brought around to gear with the wheel 28 by

the worm wheel 31 rotating the spindle 30 so that the feed roller 22 pulls upon the paper 2 causing it to be wound and bringing a clean surface in position ready for the next printing.

The fact that access can be obtained to the strip through the door of the casing is important as it enables any required data to be entered upon the paper strip 2. For instance, should the driver be stopped by a constable he can insert or get the constable to insert his name or number in the proper place on the strip. The strip may further be used for memoranda of various descriptions such as names and places of call, etc. It is also to be noted that the strip is constantly in view of the driver and also that when the number of the car is registered in connection with the time recording portion it is possible to verify that the machine used corresponds with the number of the car to prevent any kind of fraud on the part of the driver.

What I claim and desire to secure by Letters Patent is:—

1. In an indicating device of the class described, in combination, a time stamp, a paper strip adapted to have time indications printed thereon by said stamp, means controlled by the motion of a vehicle for feeding said paper strip relatively to said stamp, an inking roller adapted to be actuated to ink said stamp, a pad adapted to press said paper strip against said stamp, and means comprising a system of cranks for alternately actuating said inking roller and said pad.

2. In an indicating device of the class de-

scribed, in combination, a time stamp, a paper strip adapted to have time indications printed thereon by said stamp, means controlled by the motion of a vehicle for feeding said paper strip relatively to said stamp, a pad adapted to press said paper strip against said stamp, guiding rods operatively associated with said pad, a connecting rod operatively associated with said pad, and means comprising a system of cranks for actuating said connecting rod to cause said pad to press said strip against said stamp.

3. In an indicating device of the class described, in combination, a time stamp, a paper strip adapted to have time indications printed thereon by said stamp, means controlled by the motion of a vehicle for feeding said paper strip relatively to said stamp, a pad comprising rubber buffers mounted on a yielding base adapted to press said paper strip against said stamp, and means for actuating said pad.

4. In an indicating device of the class described, in combination, a time stamp, a paper strip adapted to have time indications printed thereon by said stamp, means controlled by the motion of a vehicle for feeding said strip relatively to said stamp, and manually actuated means for feeding said strip independently of the motion of the vehicle.

In testimony whereof I have signed my name to this specification in the presence of two subscribing witnesses.

JOHN OSBORN TONKIN.

Witnesses:

HENRY HASPER,  
WOLDEMAR HAUPT.