



INTERNATIONAL APPLICATION PUBLISHED UNDER THE PATENT COOPERATION TREATY (PCT)

(51) International Patent Classification ⁶ : A62B 18/00	A1	(11) International Publication Number: WO 97/09090 (43) International Publication Date: 13 March 1997 (13.03.97)
<p>(21) International Application Number: PCT/US96/14170</p> <p>(22) International Filing Date: 5 September 1996 (05.09.96)</p> <p>(30) Priority Data: 08/525,404 8 September 1995 (08.09.95) US</p> <p>(71) Applicant: RESPIRONICS, INC. [US/US]; Murry Rigde Corporate Center, 1001 Murry Ridge Drive, Murrysville, PA 15668-8550 (US).</p> <p>(72) Inventors: BARNETT, Shari, S.; 624 East End Avenue, Pittsburgh, PA 15221 (US). HANDKE, Patrick, M.; 416 Brunner Drive, Monroeville, PA 15146 (US). SABO, Kristine, K.; 136 Venango Court, New Kensington, PA 15068 (US). SCARBERRY, Eugene, N.; 208 Terrace Court Road, Trafford, PA 15085 (US).</p> <p>(74) Agent: GASTINEAU, Cheryl, L.; Reed Smith Shaw & McClay, P.O. Box 488, Pittsburgh, PA 15230 (US).</p>	<p>(81) Designated States: CA, JP, European patent (AT, BE, CH, DE, DK, ES, FI, FR, GB, GR, IE, IT, LU, MC, NL, PT, SE).</p> <p>Published <i>With international search report.</i> <i>Before the expiration of the time limit for amending the claims and to be republished in the event of the receipt of amendments.</i></p>	

(54) Title: RESPIRATORY MASK FACIAL SEAL

(57) Abstract

This invention is an improved flexible respiratory mask facial seal (18), as well as a respiratory mask (10) incorporating such seal. The facial seal comprises an annular member (16) including a peripheral sidewall bounded by an inner end and an outer end generally opposite the inner end. The annular member is formed of a gel substance possessing resilience characteristics corresponding to those of human fat tissue.

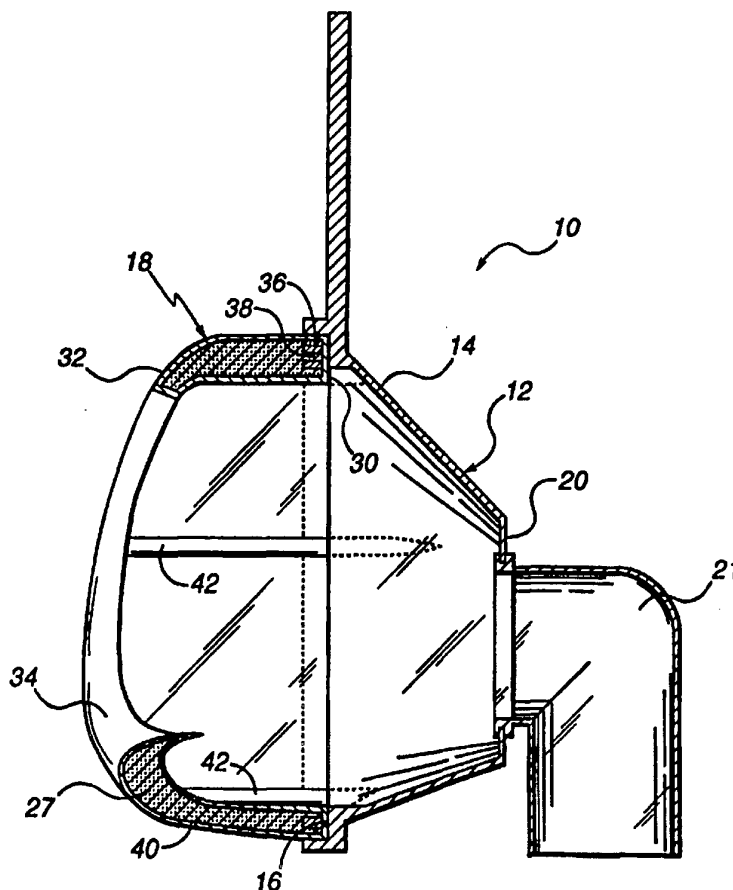

FOR THE PURPOSES OF INFORMATION ONLY

Codes used to identify States party to the PCT on the front pages of pamphlets publishing international applications under the PCT.

AM	Armenia	GB	United Kingdom	MW	Malawi
AT	Austria	GE	Georgia	MX	Mexico
AU	Australia	GN	Guinea	NE	Niger
BB	Barbados	GR	Greece	NL	Netherlands
BE	Belgium	HU	Hungary	NO	Norway
BF	Burkina Faso	IE	Ireland	NZ	New Zealand
BG	Bulgaria	IT	Italy	PL	Poland
BJ	Benin	JP	Japan	PT	Portugal
BR	Brazil	KE	Kenya	RO	Romania
BY	Belarus	KG	Kyrgystan	RU	Russian Federation
CA	Canada	KP	Democratic People's Republic of Korea	SD	Sudan
CF	Central African Republic	KR	Republic of Korea	SE	Sweden
CG	Congo	KZ	Kazakhstan	SG	Singapore
CH	Switzerland	LI	Liechtenstein	SI	Slovenia
CI	Côte d'Ivoire	LK	Sri Lanka	SK	Slovakia
CM	Cameroon	LR	Liberia	SN	Senegal
CN	China	LT	Lithuania	SZ	Swaziland
CS	Czechoslovakia	LU	Luxembourg	TD	Chad
CZ	Czech Republic	LV	Latvia	TG	Togo
DE	Germany	MC	Monaco	TJ	Tajikistan
DK	Denmark	MD	Republic of Moldova	TT	Trinidad and Tobago
EE	Estonia	MG	Madagascar	UA	Ukraine
ES	Spain	ML	Mali	UG	Uganda
FI	Finland	MN	Mongolia	US	United States of America
FR	France	MR	Mauritania	UZ	Uzbekistan
GA	Gabon			VN	Viet Nam

-2-

continuously for hours or perhaps even days. In such situations, the user will not tolerate the mask for long durations and optimum therapeutic or diagnostic objectives thus will not be achieved, or will be achieved with great difficulty and considerable user discomfort.

The prior art includes several types of respiratory face masks for the types of applications mentioned above. Perhaps the most common type of mask incorporates a smooth sealing surface extending around the periphery of the mask and exhibiting a generally uniform (i.e., predetermined or fixed) seal surface contour which is intended to be effective to seal against the user's face when force is applied to the mask with the smooth sealing surface in confronting engagement with the user's face. The sealing surface typically consists of an air or fluid filled cushion, or it may simply be a molded or formed surface of a resilient seal element made of an elastomer such as plastic, rubber, silicone, vinyl or foam. Such masks have performed well when the fit is good between the contours of the seal surface and the corresponding contours of the user's face. However, if the seal fit is not good, there will be gaps in the seal-to-face interface and excessive force will be required to compress the seal member and thereby attain a satisfactory seal in those areas where the gaps occur. Such excessive force is unacceptable as it produces high pressure points elsewhere on the face of the user where the mask seal contour is forcibly deformed against the face to conform to the user's facial contours. This will produce considerable user discomfort and possible skin irritation and breakdown anywhere the applied force exceeds the local perfusion pressure, which is the pressure that is sufficient to cut off surface blood flow. Ideally, contact forces should be limited between the mask and the user's face to avoid exceeding the local perfusion

-3-

pressure even at points where the mask seal must deform considerably.

5 The problem of seal contact force exceeding desirable limits is even more pronounced when the positive pressure of the gas being supplied is relatively high or is cyclical to high levels. Since the mask seals by virtue of confronting contact between the mask seal and the user's face, the mask must be held against the face with a force sufficient to seal against leakage of the peak pressure of the supplied gas. Thus, for conventional masks, when the supply pressure is high, headstraps or other mask restraints must be tightly fastened. This produces high localized pressure on the face, not only in the zone of the mask seal but at various locations along the extent of the retention straps as well. This too will result in severe discomfort for the user after only a brief time. Even in the absence of excessive localized pressure points, the tight mask and headstraps often may become extremely uncomfortable and user discomfort may well cause discontinued cooperation with the regimen.

25 Examples of respiratory masks possessing continuous cushion sealing characteristics of the type just described are provided in U.S. Patent Nos. 2,254,854 and 2,931,356.

30 U.S. Patent No. 5,181,506 describes a protective gas mask for military applications. The mask includes a three-layer face piece, the central layer of which is a thick layer of relatively stiff material having preformed V-shaped channels. The channels are "overfilled" with a gel or both gel and compressed air so as to create bulges in an inner face-contacting layer which are adapted to seal against the contours of a user's face. The inherent stiffness of the central layer in combination with the structural rigidity provided by the V-shaped channels,

-4-

especially when overfilled with gel/air, results in a comparatively unyielding facial seal. Indeed, the mask is deployed in combination with a tightly fitting hood in order to draw the face piece firmly against the user's head to thereby generate the desired facial seal. As will be appreciated, the comfort afforded such a construction is quite limited and certainly not appropriate for those applications, such as respiratory therapy situations, where a user must occasionally wear a mask for prolonged periods of time.

Several classes of cushion materials, including gels and foams, were analyzed in a study by S.F.C. Stewart, V. Palmieri and G.V.B. Cochran, Arch. Phys. Med. Rehabil., Vol. 61, (May 1980). That study compared the relative advantages and disadvantages of such cushion materials when used as wheelchair cushions, specifically the effects of such materials on skin temperature, heat flux and relative humidity at the skin-cushion interface. Each of these factors, along with applied pressure in excess of local perfusion pressure, has been identified as a contributor to breakdown of skin tissue at the skin-cushion interface.

In that study, foam cushions were reported to increase skin temperatures by several degrees after a few hours of use. This was suggested to be a result of the comparatively low heat flux characteristics of foam materials. That is, the foam materials and the air entrapped within them tend to be poor absorbers and conductors of heat. Conversely, gel pads, as a group, showed a considerably higher heat flux than foam, sufficient in fact to maintain skin temperatures relatively constant after several hours of use. The sole benefit of foam versus gel reported in the study was that foams produced lesser relative humidity than gels at the skin-cushion interface. This was attributed to the open

-5-

cell structure of the foams which provide a pathway through which moisture can diffuse. This seeming advantage is somewhat problematic, however, in that open
5 cell foam tends to promote bacteria growth when exposed to perspiration. Bacteria, in turn, contaminates the foam thereby considerably hindering its useful service life.

10 These and other detrimental characteristics have been observed as well in the foam-type respiratory mask seals discussed above. Hence, apart from generally failing to provide optimum sealing with respect to a user's face, the inherent qualities of foam mask seals have been linked to skin irritation and breakdown, particularly at some of the more prominent facial contours
15 such as the cheek bones and bridge of the nose.

Moreover, whether air, fluid or, in the case of U.S. Patent No. 5,181,506, gel filled, or whether formed as an elastomer such as foam, plastic, rubber, silicone and the like, the resiliency or recoil characteristics of
20 presently available cushion type respiratory mask seals have not been well suited to form an effective seal with the topography of the user's face in the absence of considerable headstrap tensile forces. The present inventors have discovered that headstrap tensile forces
25 and, therefore, the compressive forces exerted by the mask against a user's face, can be reduced substantially with respect to existing cushion-type respiratory masks when the mask cushion is fabricated from materials having recoil characteristics analogous to that of human fat.
30 Such a cushion has been found to behave much like natural biological tissue and tends to conform naturally to a user's face under the influence of very low headstrap forces. The present inventors have also discovered that, in addition to their other aforementioned advantages, gel
35 materials can be produced that simulate the recoil properties of human fat tissue.

-6-

An advantage exists, therefore, for a respiratory mask facial seal comprising a seal cushion formed of a gel that affords an effective yet comfortable and non-damaging seal with a user's facial contours.

SUMMARY OF THE INVENTION

The present invention provides an improved flexible respiratory mask facial seal, as well a respiratory mask incorporating such seal, which reliably and comfortably seals the facial contours of a user.

The facial seal comprises an annular member including a peripheral sidewall bounded by an inner end and an outer end generally opposite the inner end. The inner end is adapted for attachment to the shell or body portion of a respiratory mask and the outer end defines a contoured sealing surface adapted for confronting sealing engagement with a user's face.

The annular member is formed of a gel substance such as a viscoelastic polyurethane polymer possessing resilience or recoil characteristics corresponding to those of human fat tissue. The annular member may be deployed with or without a protective covering. In the absence of such a covering, the inherent tacky quality of the gel substance serves to enhance adhesion of the facial seal to the user's face. Alternatively, if tackiness is not desired, the surface of the annular member may be covered with a coating of powdered talc, silicone or similar biocompatible material. Most preferably, however, the annular member is encapsulated in a thin, pliable, membranous covering to enhance the durability and washability of the facial seal.

Because the facial seal simulates the recoil characteristics of human fat tissue, the user experiences

-7-

the sensation of a natural substance against his skin when the mask is donned. Consequently, a mask provided with such a cushion can be comfortably urged into continuous sealing engagement with a user's face with less headstrap tension than other masks heretofore known in the art. Furthermore, the fat-like qualities of the gel cause the gel to effectively fill gaps and mold to other facial contours thereby minimizing leakage of pressurized gas supplied to the mask. The gel material also serves to efficiently dissipate heat while resisting the bacteria growth associated with foam type mask seals.

Other details, objects and advantages of the present invention will become apparent as the following description of the presently preferred embodiments and presently preferred methods of practicing the invention proceeds.

BRIEF DESCRIPTION OF THE DRAWINGS

The invention will become more readily apparent from the following description of preferred embodiments thereof shown, by way of example only, in the accompanying drawings, wherein:

Figure 1 is a front elevation view of a respiratory mask including a first preferred embodiment of a facial seal constructed according to the present invention;

Figure 2 is a side elevation view of the respiratory mask of Figure 1 when in confronting, sealing engagement with a user's face, the respiratory mask being schematically depicted in communication with a source of respiratory gas;

-8-

Figure 3 is a cross-section taken along line III-III of Figure 1;

5 Figure 4 is a cross-section taken along line IV-IV of Figure 2; and

Figure 5 is an elevational cross-section view similar to Figure 3 of a respiratory mask including a further preferred embodiment of a facial seal constructed according to the present invention.

10

DETAILED DESCRIPTION OF THE INVENTION

Referring initially to Figures 1 and 2, there is generally indicated at 10 a respiratory mask including a shell or body portion 12 having an open side 14 that defines an annular surface 16 (perhaps most clearly illustrated in Figure 3) to which is sealingly affixed a facial seal 18 constructed according to a first presently preferred embodiment of the instant invention. The mask body portion 12 is preferably, although not necessarily, a generally rigid formed structural shell, whereas facial seal 18 is a flexible, resilient unitary member which will be described in greater detail hereinafter.

20 Body portion 12 also defines an opening 20 to which there may be attached a fluid coupling means such as a swivel coupling 21 or other suitable means. The opening 25 20 and any intervening coupling means 21 connect mask 10 via conduit means (represented by dashed line 22) to a source of gas 24, e.g., a blower or other suitable means for providing a flow of pressurized breathing gas, for administration of the gas to a user 26. The mask shown is a nasal mask which accommodates the nasal regions of the user's face. It is to be understood, however, that the invention also contemplates a full face or oral/nasal mask that accommodates both the mouth and nose of a user. As

30

- 9 -

is conventional, mask shell 12 also preferably includes fastening means such as tabs 25 or the like to which may be connected suitable adjustable retention straps (not illustrated) for retaining the mask with respect to the user's face.

Seal 18 includes a solid yet highly resilient and self-sustaining compressible annular member 27 comprising a peripheral wall portion 28 having an annular base or inner end 30 (Figure 3) configured substantially similar to the annular surface 16 of shell 12 to which it may be fixedly attached. Peripheral wall portion 28 further establishes an outer end 32 generally opposite inner end 30. The outer end 32 defines a generally annular contoured sealing surface 34 adapted for confronting, sealing engagement with a user's face. As will be more fully developed later herein, the contour of sealing surface 34 closely approximates the surface contour of a user's facial structure in the areas of the bridge of the nose, the cheeks adjacent the nose, the space intermediate the nose and upper lip, and the intervening areas contiguous to these. For a full face mask (not illustrated) the sealing surface 34 would be contoured to accommodate the user's chin in lieu of the area intermediate the nose and upper lip. In either case, variation in user facial structure, especially in the area of the bridge of the nose, for example, makes considerable seal flexibility necessary to accommodate the many different facial contours likely to be encountered.

Figures 3 and 4 reveal in more detail the respiratory mask seal 18. In accordance with the present invention, at least the seal or face-contacting portion or, more preferably (as illustrated), substantially the entirety of the annular member 27 is formed from a gel substance such as a viscoelastic polyurethane polymer possessing resilience or recoil characteristics

-10-

corresponding substantially to those of human fat tissue. More specifically, the facial seal 18 including the annular member 27 preferably has a resiliency, as defined by durometer measured on the Shore 00 scale which is used to gauge the resiliency of very soft resilient materials, of about 10 or softer and, most preferably, about 0. Such resiliency, corresponds substantially to that of human fat tissue which also exhibits a durometer reading of 0 on a Shore 00 scale. In respect to the facial seal embodiment shown in Figures 1 through 4, the durometer of facial seal 18 corresponds to the resultant durometers of the annular member 27 and its later described protective covering (whose durometer is essentially negligible because of the thinness and pliability of the covering). As for the facial seal illustrated in Figure 5 wherein the annular member 27 has no protective covering, the durometer of the facial seal is that of the annular member.

Although inherently capable of filling spatial voids, human fat tissue has negligible structural integrity and may not be self-sustaining. Consequently, any respiratory mask facial seal possessing structural characteristics essentially identical to fat would be impractical from a usage standpoint. That is, if a facial seal were fabricated from a material structurally indistinguishable from human fat tissue in terms of resiliency, it may tend to sag into an amorphous shape under the influence of gravity and thus would not effectively conform to the contours of a user's face even if headstrap tension was quite high. It will be appreciated, therefore, that a properly designed facial seal must substantially but not identically mimic human fat tissue from a structural, particularly resiliency, perspective. Stated differently, the facial seal must exhibit some measurable recoil "memory" whereby it is structurally self-sustaining, capable of gently conforming to the topography of a user's face under the influence of

-11-

low headstrap tensile forces, resistant to distorting gravitational effects and self-restorable to its original configuration when removed from contact with the user's face. It must also be resistant to distortion due to positive gas pressure supplied to the mask. To simultaneously achieve these and other beneficial properties, the annular member 27 according to the present invention is preferably formed from a gel substance that, while virtually indistinguishable from human fat tissue when measured on the Shore 00 scale, exhibits a resiliency or durometer on the Shore 000 scale (which scale is used to measure the resiliency of extremely soft resilient materials) of from about 20 to about 45. By comparison, human fat tissue registers a durometer of about 10 on the Shore 000 scale.

The annular member 27 may be fabricated by conventional molding techniques. For example, liquid polyurethane polymer including any plasticizers and other modifiers necessary to achieve desired finished product properties is poured or injected into an appropriately configured mold. The polymer is then permitted to cure, either with or without the application of heat depending upon the specific composition and setting characteristics of the polymer, until the product achieves its desired solid gel form. Because the polymer of the annular member does not have sufficient structural integrity to reliably adhere directly to the body portion 12 of the mask, the facial seal 18 also preferably comprises attachment means 36 which may be integrally molded into the inner end 30 of the annular member during its formation. Attachment means 36 is desirably constructed as a substantially rigid annular ring having shape corresponding to that of the inner end 30 and a wall thickness less than or equal to that of the wall thickness of the peripheral wall portion 28. At minimum, however, attachment means 36 should comprise a member less resilient than the gel substance of

-12-

the annular member. To enhance bonding of the attachment means 36 to the annular member 27, the attachment means desirably includes anchorage means 38. The anchorage means may comprise spaced apart formations of the attachment means defining openings or similar structures into or around which the fluid polymer may flow and ultimately cure during formation of the annular member.

Annular member 27 also preferably comprises a plurality of integral bosses 42 molded into the peripheral wall portion 28 during formation of the annular member which extend from the inner end 30 toward the outer end 32. Bosses 42 provide gentle structural support to the annular member and promote uniform compression of the annular member when such member is in contact with a user's face. The bosses are preferably symmetrically disposed about the peripheral wall portion and preferably correspond in number and location to the anchorage means 38. As shown in Figure 3, a presently preferred construction includes five such bosses 42 corresponding to five anchorage means 38.

As previously mentioned, the presently preferred embodiment of facial seal 18 contemplates that the annular member 27 be covered by a protective covering. Such covering means is identified by reference numeral 40 in the drawing figures. The covering means functions to increase the durability of the annular member while also permitting easy cleaning of the facial seal. Covering means 40 must satisfy several physical criteria. It must, inter alia: (1) resist tearing and puncturing, (2) tightly conform to the annular member 27 without changing or deforming the contours thereof, (3) be chemically compatible with the annual member, (4) be biocompatible and non-irritating to a user's skin, and (5) be sufficiently thin and supple such that its presence has a negligible impact on the resultant durometer of the facial

-13-

seal 18. In this regard, covering means 40 preferably comprises a thin (approximately 2 to 10 mils thick) flexible plastic film. Urethane has been found to be preferable for this particular purpose as such material meets not only the objectives of the present invention but is also comparatively inexpensive and easy to apply to the surface of the annular member 27. The covering means 40 may be applied to the annular member by any suitable process. For instance, liquid urethane may be applied by spraying or dipping and then permitted to cure. Preferably, however, the urethane is prefabricated by vacuum forming so as to produce a skin of controllable and uniform thickness which is subsequently vacuum formed to the annular member using conventional techniques.

Once the facial seal 18 is fully assembled, it may be attached to the body portion 12 of a respiratory mask by coating the inner end 30 of the facial seal and/or the annular seating surface 16 of the mask body portion 12 with a suitable adhesive and then pressing the inner end 30 into abutment with the seating surface 16 whereupon the adhesive is allowed to cure.

In Figure 5, wherein like references designate like or corresponding parts to those previously discussed, there is illustrated a further preferred embodiment of the facial seal of the present invention which is identified herein by reference numeral 118. Facial seal 118 differs from facial seal 18 essentially in that the annular member 27 thereof has no protective covering means on its outer surface. In all other material respects, facial seal 118 is constructed and functions substantially identically to facial seal 18.

The exposed surface of the annular member 27 of is tacky. As such, the inherent tackiness of the contoured sealing surface 34 of the annular member may

-14-

thus be used to the user's advantage by enhancing adhesion of the facial seal to the user's face. In the alternative, if tackiness is not desired, the surface of the annular member 27 of facial seal 118 may be covered with a coating of powdered talc, silicone or similar biocompatible material.

As presently contemplated, the wall thickness of the peripheral wall portion 28 of the annular seal member 27 of the facial seals 18 and 118, excluding bosses 42, preferably ranges from about 0.2 to 0.3 inches. The weight of the facial seals 18, 118 depending on the size of mask bodies 12 with which they are used, ranges from about 1 to 2 ounces, a weight which has been discovered to be virtually unnoticeable to patients who have worn masks constructed according to the present invention in clinical tests. Furthermore, the fat-like resiliency qualities of the gel material which forms the annular member 27 creates in the wearer a comparatively cool and natural tactile sensation when the facial seal is in contact with the user's face. And, much like human fat tissue would perform, the facial seals 18, 118 effectively fill gaps and mold to the user's facial topography thereby minimizing leakage of gas supplied to the mask. Indeed, experimental testing has shown that respiratory masks fitted with facial seals in accordance with the present invention exhibit minimal gas leaks with headstrap tensile forces of 3 pounds or less, a value substantially less than related masks presently known in the art. The facial seals described herein thus enable respiratory masks to be worn by users for prolonged periods with little or no measurable discomfort. This phenomenon is especially important to users who must wear respiratory masks for extended periods such as patients undergoing respiratory therapy. Such individuals find that because of the comfort afforded by the facial seals 18, 118, their compliance with the respiratory treatment increases and

-15-

the therapeutic benefits of the treatment are more fully realized.

5 As an alternative to the embodiments discussed above, it is also contemplated that a respiratory mask of the present invention may be constructed as a one-piece member rather than as a separate facial seal joined to a mask body. In such case, the respiratory mask may be fabricated as a unitary member formed from substances of
10 increasingly softer durometers, as considered in a direction from that portion of the mask corresponding to the mask body toward that portion corresponding to the facial seal, such that the softest materials, comprising the previously discussed gel substance and possessing the resiliency characteristics described hereinabove, would
15 constitute the seal or face-contacting portion of the annular member.

Although the invention has been described in detail for the purpose of illustration, it is to be
20 understood that such detail is solely for that purpose and that variations can be made therein by those skilled in the art without departing from the spirit and scope of the invention except as it may be limited by the claims.

-16-

CLAIMS

What is claimed is:

5 1. A flexible, resilient respiratory mask
facial seal for sealing engagement with the face of a
human user to form a sealed interface encompassing a
predetermined portion of such user's face, said facial
seal being operatively connectable to a source of
breathing gas, said facial seal comprising a peripheral
10 wall portion having an inner end and an outer end opposite
said inner end, said inner end being attachable to a body
of a respiratory mask and said outer end including a seal
portion having a contoured sealing surface for sealing
engagement with a user's face, at least said seal portion
15 being formed from a gel substance having a resiliency
substantially corresponding to that of human fat tissue.

 2. The facial seal of claim 1 wherein said
resiliency is defined as a Shore 00 durometer of less than
about 10.

20 3. The facial seal of claim 2 wherein said
resiliency is defined as a Shore 000 durometer of from
about 20 to about 45.

 4. The facial seal of claim 1 wherein said gel
substance is a viscoelastic polyurethane polymer.

25 5. The facial seal of claim 1 further
comprising means for attaching said facial seal to a body
portion of a respiratory mask.

-17-

6. The facial seal of claim 5 wherein said attaching means comprise a member less resilient than said gel substance connected to said gel substance.

5 7. The facial seal of claim 6 wherein said less resilient member comprises means for anchoring said gel substance to said less resilient member.

10 8. The facial seal of claim 1 further comprising a protective covering surrounding said gel substance.

9. The facial seal of claim 8 wherein said protective covering comprises a pliable membrane.

10. The facial seal of claim 9 wherein said membrane has a thickness of from about 2 to about 10 mils.

15 11. The facial seal of claim 10 wherein said membrane is formed from urethane.

12. The facial seal of claim 1 wherein said facial seal comprises an annular member formed from said gel substance.

20 13. A respiratory mask operatively connectable to a source of breathing gas and comprising:

a respiratory mask body; and

25 a flexible, resilient respiratory mask facial seal for engagement with the face of a human user to form a sealed interface encompassing a predetermined portion of such user's face, said facial seal comprising a peripheral wall portion having an inner end and an outer end opposite said inner end, said inner end being attachable to said respiratory mask body and said outer end including a seal

-18-

5 portion having a contoured sealing surface for sealing engagement with a user's face, at least said seal portion being formed from a gel substance having a resiliency substantially corresponding to that of human fat tissue.

14. The respiratory mask of claim 13 wherein said resiliency is defined as a Shore 00 durometer of less than about 10.

10 15. The respiratory mask of claim 14 wherein said resiliency is defined as a Shore 000 durometer of from about 20 to about 45.

16. The respiratory mask of claim 13 wherein said gel substance is a viscoelastic polyurethane polymer.

15 17. The respiratory mask of claim 13 further comprising means for attaching said facial seal to a body portion of a respiratory mask.

18. The respiratory mask of claim 17 wherein said attaching means comprise a member less resilient than said gel substance connected to said gel substance.

20 19. The respiratory mask of claim 18 wherein said less resilient member comprises means for anchoring said gel substance to said less resilient member.

25 20. The respiratory mask of claim 13 further comprising a protective covering surrounding said gel substance.

21. The respiratory mask of claim 20 wherein said protective covering comprises a pliable membrane.

-19-

22. The respiratory mask of claim 21 wherein said membrane has a thickness of from about 2 to about 10 mils.

5 23. The respiratory mask of claim 22 wherein said membrane is formed from urethane.

24. The respiratory mask of claim 13 wherein said facial seal comprises an annular member formed from said gel substance.

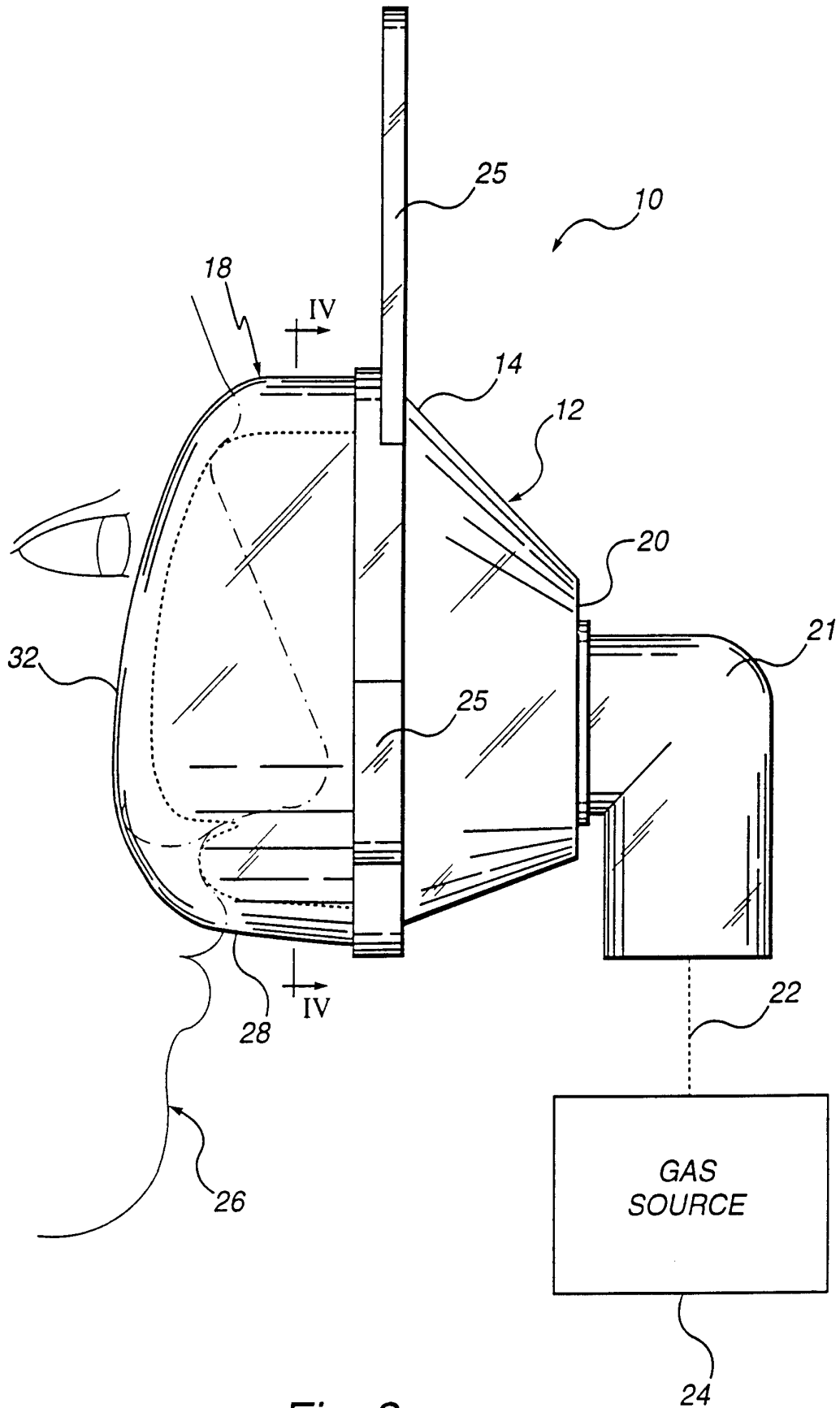

Fig. 2

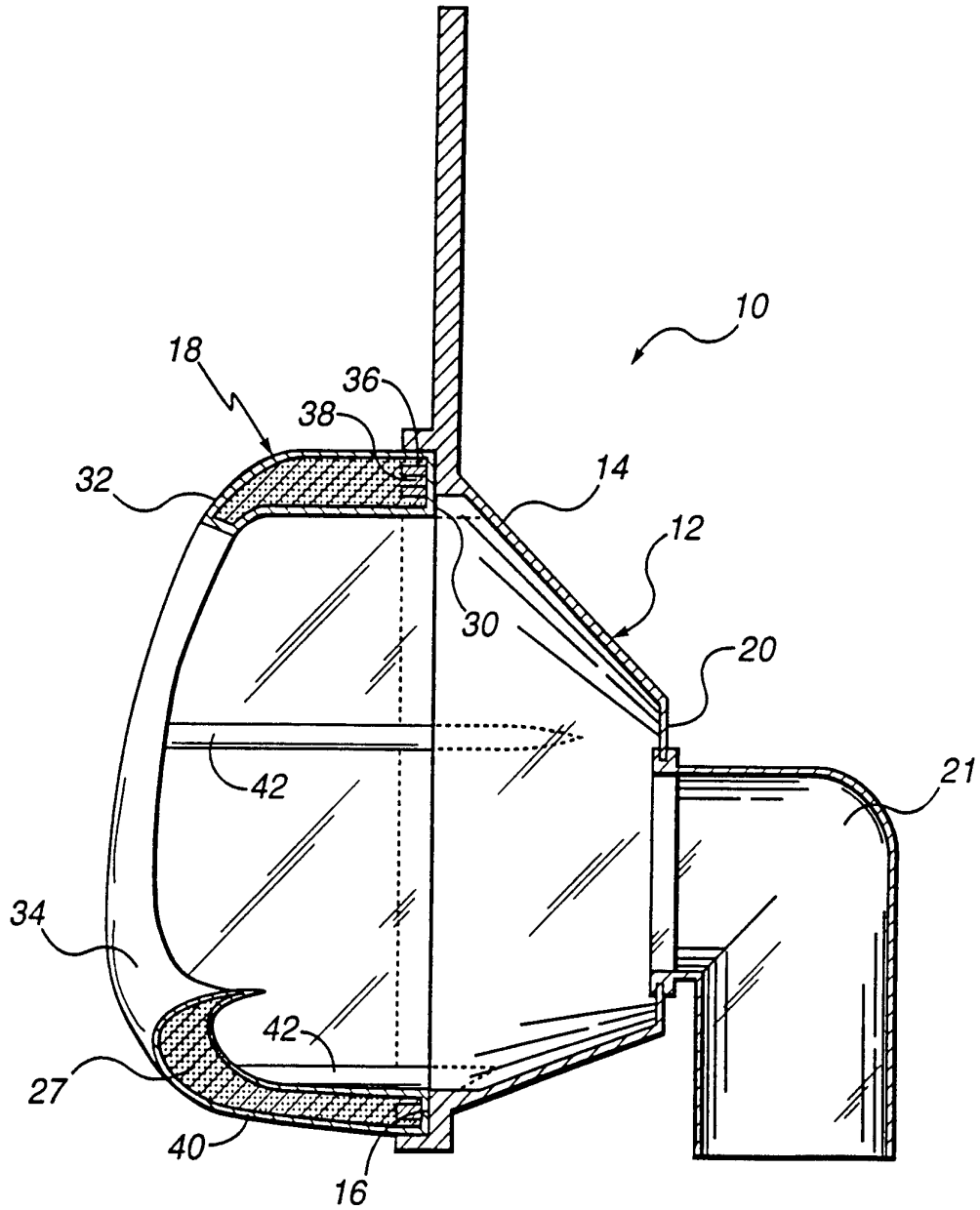

Fig. 3

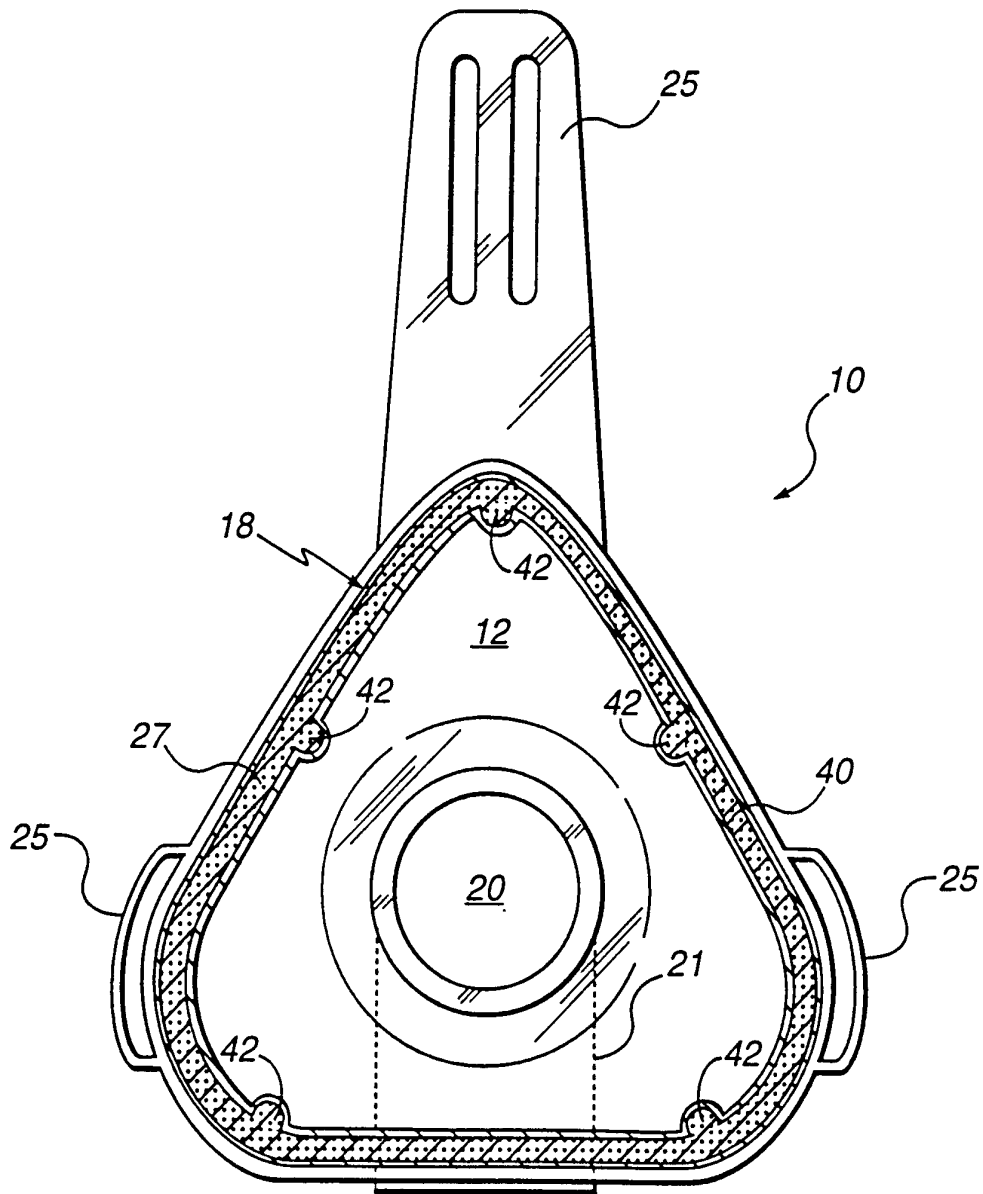

Fig. 4

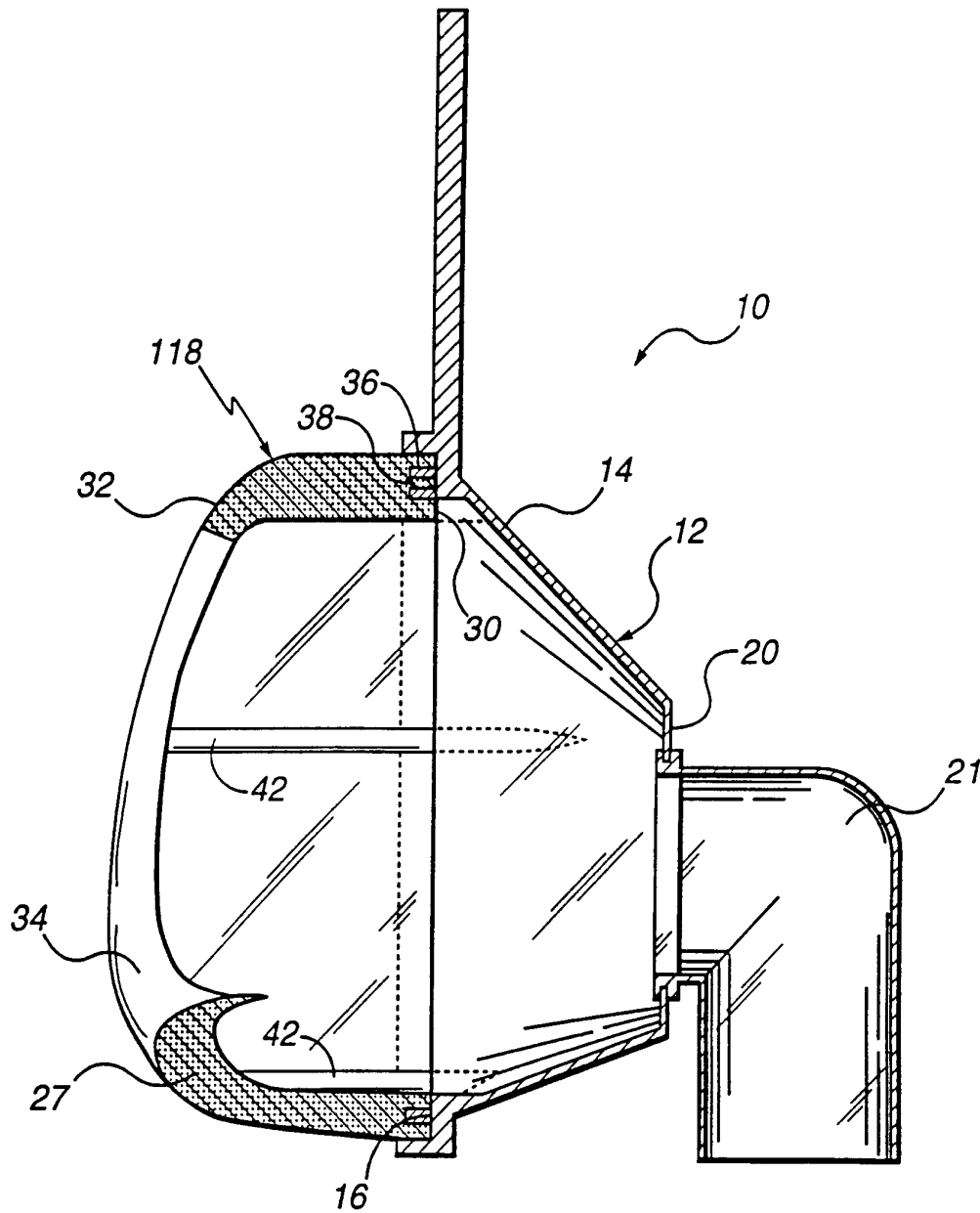



Fig. 5

INTERNATIONAL SEARCH REPORT

International application No.
PCT/US96/14170

A. CLASSIFICATION OF SUBJECT MATTER IPC(6) : A62B 18/00 US CL : 128/205.25, 206.14, 206.21, 206.24, 206.25, 206.26, 206.28 According to International Patent Classification (IPC) or to both national classification and IPC		
B. FIELDS SEARCHED Minimum documentation searched (classification system followed by classification symbols) U.S. : 128/205.25, 106.14, 206.21, 206.24, 206.25, 206.26, 206.28 Documentation searched other than minimum documentation to the extent that such documents are included in the fields searched Electronic data base consulted during the international search (name of data base and, where practicable, search terms used) APS		
C. DOCUMENTS CONSIDERED TO BE RELEVANT		
Category*	Citation of document, with indication, where appropriate, of the relevant passages	Relevant to claim No.
Y	US 2,917,045 A (SCHILDKNECHT et al) 15 December 1959, col. 1 lines 15-18; col. 2, lines 45-49 and 54-58; and col. 3, lines 23-26 and 68-76.	1-24
Y	US 2,625,155 A (ENGELDER) 13 January, 1953, col. 5, lines 46-66.	1-24
Y	CA 618,807 A (GALLEHER, JR.) 25 April 1961, col. 2, lines 47-49	1-24
<input type="checkbox"/> Further documents are listed in the continuation of Box C. <input type="checkbox"/> See patent family annex.		
* Special categories of cited documents:	*T* later document published after the international filing date or priority date and not in conflict with the application but cited to understand the principle or theory underlying the invention	
A document defining the general state of the art which is not considered to be of particular relevance	*X* document of particular relevance; the claimed invention cannot be considered novel or cannot be considered to involve an inventive step when the document is taken alone	
E earlier document published on or after the international filing date	*Y* document of particular relevance; the claimed invention cannot be considered to involve an inventive step when the document is combined with one or more other such documents, such combination being obvious to a person skilled in the art	
L document which may throw doubts on priority claim(s) or which is cited to establish the publication date of another citation or other special reason (as specified)	*&* document member of the same patent family	
O document referring to an oral disclosure, use, exhibition or other means		
P document published prior to the international filing date but later than the priority date claimed		
Date of the actual completion of the international search 02 DECEMBER 1996	Date of mailing of the international search report 27 DEC 1996	
Name and mailing address of the ISA/US Commissioner of Patents and Trademarks Box PCT Washington, D.C. 20231 Facsimile No. (703) 305-3590	Authorized officer  VIRENDRA SRIVASTAVA Telephone No. (703) 308-0959	