



(51) International Patent Classification:

A61B 17/34 (2006.01)

(21) International Application Number:

PCT/US2019/037488

(22) International Filing Date:

17 June 2019 (17.06.2019)

(25) Filing Language:

English

(26) Publication Language:

English

(30) Priority Data:

16/021,386 28 June 2018 (28.06.2018) US

(71) Applicant: **CONMED CORPORATION** [US/US]; 525 French Road, Utica, NY 13502 (US).

(72) Inventors: **SILVER, Mikiya**; 15 Orange Street, Apt. 404, New Haven, CT 06510 (US). **KANE, Michael, J.**; 3 William Lane, Clinton, CT 06413 (US).

(74) Agent: **WOFSY, Scott, D.** et al.; Locke Lord LLP, P.O. Box 55874, Boston, MA 02205 (US).

(81) Designated States (unless otherwise indicated, for every kind of national protection available): AE, AG, AL, AM, AO, AT, AU, AZ, BA, BB, BG, BH, BN, BR, BW, BY, BZ, CA, CH, CL, CN, CO, CR, CU, CZ, DE, DJ, DK, DM, DO, DZ, EC, EE, EG, ES, FI, GB, GD, GE, GH, GM, GT, HN,

HR, HU, ID, IL, IN, IR, IS, JO, JP, KE, KG, KH, KN, KP, KR, KW, KZ, LA, LC, LK, LR, LS, LU, LY, MA, MD, ME, MG, MK, MN, MW, MX, MY, MZ, NA, NG, NI, NO, NZ, OM, PA, PE, PG, PH, PL, PT, QA, RO, RS, RU, RW, SA, SC, SD, SE, SG, SK, SL, SM, ST, SV, SY, TH, TJ, TM, TN, TR, TT, TZ, UA, UG, US, UZ, VC, VN, ZA, ZM, ZW.

(84) Designated States (unless otherwise indicated, for every kind of regional protection available): ARIPO (BW, GH, GM, KE, LR, LS, MW, MZ, NA, RW, SD, SL, ST, SZ, TZ, UG, ZM, ZW), Eurasian (AM, AZ, BY, KG, KZ, RU, TJ, TM), European (AL, AT, BE, BG, CH, CY, CZ, DE, DK, EE, ES, FI, FR, GB, GR, HR, HU, IE, IS, IT, LT, LU, LV, MC, MK, MT, NL, NO, PL, PT, RO, RS, SE, SI, SK, SM, TR), OAPI (BF, BJ, CF, CG, CI, CM, GA, GN, GQ, GW, KM, ML, MR, NE, SN, TD, TG).

Published:

— with international search report (Art. 21(3))

(54) Title: FLEXIBLE SINGLE LUMEN GAS SEALED ACCESS PORT FOR USE DURING ROBOTICALLY ASSISTED ENDOSCOPIC SURGICAL PROCEDURES

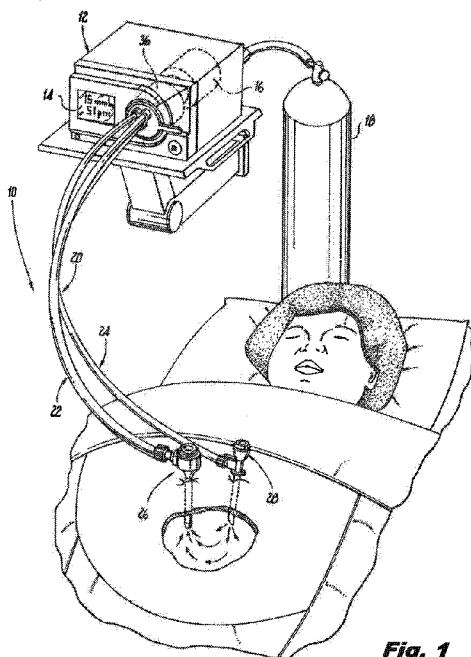


Fig. 1

(57) Abstract: A gas sealed access port is disclosed including a proximal housing having a central lumen providing gas sealed access to the surgical cavity, an inlet path for communicating with a source of pressurized gas, a tapered neck portion and an interior cavity accommodating an annular jet assembly for receiving pressurized gas from the inlet path to generate a gaseous seal within the tapered neck portion, and an elongated tubular body extending from the tapered neck portion in communication with the central lumen and including a flexible proximal body portion and a rigid distal body portion.



**FLEXIBLE SINGLE LUMEN GAS SEALED ACCESS PORT  
FOR USE DURING ROBOTICALLY ASSISTED  
ENDOSCOPIC SURGICAL PROCEDURES**

5 **CROSS-REFERENCE TO RELATED APPLICATION**

This application claims the benefit of priority to U.S. Patent Application Serial No. 16/021,386 filed June 28, 2018 the disclosure of which is herein incorporated by reference in its entirety.

10 **BACKGROUND OF THE INVENTION**

**Field of the Invention**

The subject invention is directed to endoscopic surgery, and more particularly, to a surgical gas circulation system with multi-lumen tube set connected with a single lumen gas sealed access port and a single lumen valve sealed access port for use during  
15 an endoscopic or laparoscopic surgical procedure.

**Description of Related Art**

Laparoscopic or "minimally invasive" surgical techniques are becoming commonplace in the performance of procedures such as cholecystectomies, appendectomies, hernia repair and nephrectomies. Benefits of such procedures include  
20 reduced trauma to the patient, reduced opportunity for infection, and decreased recovery time. Such procedures within the abdominal (peritoneal) cavity are typically performed through a device known as a trocar or cannula, which facilitates the introduction of laparoscopic instruments into the abdominal cavity of a patient.

Additionally, such procedures commonly involve filling or "insufflating" the  
25 abdominal cavity with a pressurized fluid, such as carbon dioxide, to create an operating space, which is referred to as a pneumoperitoneum. The insufflation can be carried out by a surgical access device, such as a trocar, equipped to deliver insufflation

fluid, or by a separate insufflation device, such as an insufflation (veress) needle.

Introduction of surgical instruments into the pneumoperitoneum without a substantial loss of insufflation gas is desirable, in order to maintain the pneumoperitoneum.

During typical laparoscopic procedures, a surgeon makes three to four small  
5 incisions, usually no larger than about twelve millimeters each, which are typically made with the surgical access devices themselves, often using a separate inserter or obturator placed therein. Following insertion, the obturator is removed, and the trocar allows access for instruments to be inserted into the abdominal cavity. Typical trocars provide a pathway to insufflate the abdominal cavity, so that the surgeon has an open  
10 interior space in which to work.

The trocar must also provide a way to maintain the pressure within the cavity by sealing between the trocar and the surgical instrument being used, while still allowing at least a minimum amount of freedom of movement for the surgical instruments. Such instruments can include, for example, scissors, grasping instruments, and occluding  
15 instruments, cauterizing units, cameras, light sources and other surgical instruments. Sealing elements or mechanisms are typically provided on trocars to prevent the escape of insufflation gas from the abdominal cavity. These sealing mechanisms often comprise a duckbill-type valve made of a relatively pliable material, to seal around an outer surface of surgical instruments passing through the trocar.

20 SurgiQuest, Inc., a wholly owned subsidiary of ConMed Corporation has developed unique gas sealed surgical access devices that permit ready access to an insufflated surgical cavity without the need for conventional mechanical valve seals, as described, for example, in U.S. Patent No. 7,854,724. These devices are constructed from several nested components including an inner tubular body portion and a coaxial  
25 outer tubular body portion. The inner tubular body portion defines a central lumen for

introducing conventional laparoscopic surgical instruments to the abdominal cavity of a patient and the outer tubular body portion defines an annular lumen surrounding the inner tubular body portion for delivering insufflation gas to the abdominal cavity of the patient and for facilitating periodic sensing of abdominal pressure.

5           While these earlier developed dual lumen gas sealed access devices provide significant benefits and improvements over conventional single lumen valve sealed access devices, they do present certain disadvantages in the performance of a laparoscopic surgical procedure. In particular, because these earlier developed dual lumen gas sealed access devices are constructed with two coaxial tubular body  
10 portions, the effective outer diameter of the tubular body of the access device is significantly greater than the effective outer diameter of the tubular body of a conventional single lumen valve sealed access device.

For example, the outer diameter of the dual lumen gas sealed access device may be at least 2.0 mm greater than the outer diameter of a conventional single lumen valve  
15 sealed access device. Consequently, the length of the incision that is required to introduce the dual lumen access device into the abdominal cavity will be greater than the typical incision that is made for introducing a conventional single lumen valve sealed access device. This larger incision can increase the degree of patient trauma, cause larger and more visible scars for the patient, more pain or pain medication, and  
20 more difficult wound closure for the surgeon.

It would be beneficial therefore to provide a gas sealed surgical access device that overcomes the disadvantages associated with earlier developed dual lumen gas sealed access devices, such as those disclosed in U.S. Patent No. 7,854,724, while maintaining the substantial benefits they provide over conventional single lumen valve  
25 sealed access devices. The subject invention provides such a novel access device and

a filtered tube set for the device for use in endoscopic surgery, which is described in detail herein below.

**SUMMARY OF THE DISCLOSURE**

The subject invention is directed to a new and useful system for performing an endoscopic or laparoscopic surgical procedure in a surgical cavity of a patient. The system includes a multi-lumen tube set including a dual lumen portion and a single  
5 lumen portion. The dual lumen portion of the tube set has a pressurized gas line and a return gas line, which together facilitate gas recirculation relative to the surgical cavity of the patient. The single lumen portion of the tube set has a gas supply and sensing line for delivering insufflation gas to the surgical cavity of the patient and for periodically sensing pressure within the surgical cavity of the patient. Preferably, the  
10 tube set is operatively associated with a multi-path filter cartridge assembly.

The system further includes a first access port having a proximal housing portion and an elongated tubular body portion extending distally from the proximal housing portion and defining a central cannula or bore. The proximal housing portion of the first access port has an inlet path for communicating with the pressurized gas line  
15 of the tube set and an outlet path for communicating with the return gas line of the tube set. The proximal housing portion accommodates an annular jet assembly for receiving pressurized gas from the inlet path and for generating a gaseous sealing zone within the central cannula of the body portion to maintain a stable pressure within the surgical cavity of the patient.

20 The system also includes a second access port having a proximal housing portion and a tubular body portion extending from the proximal housing portion. The proximal housing portion of the second access port accommodates a mechanical valve for sealing the tubular body portion and an inlet path for communicating with the gas supply and sensing line of the tube set.

Preferably, the first access port is adapted and configured to perform smoke evacuation from the surgical cavity of the patient in conjunction with the second access port. In one embodiment of the invention, the first access port is adapted and configured to permit air entrainment, emergency relief of cavity pressure and instrument access into the central cannula during a surgical procedure. In another embodiment of the invention, the first access port is adapted and configured to permit air entrainment and emergency relief of cavity pressure, but without permitting instrument access into and/or through the central cannula. In this regard, the central bore of the cannula may be shaped, dimensioned, louvered or otherwise configured to prevent instrument access therethrough.

In another embodiment, the first access port includes a proximal housing portion that is adapted to be selectively coupled with the tubular body portion thereof, and wherein the tubular body portion is configured for manipulation by a robotic surgical system, such as, for example, Da Vinci robotic system manufactured by Intuitive Surgical, Inc. For example, the proximal housing portion may be selectively coupled to the tubular body portion by a pair of diametrically opposed cantilevered or spring loaded locking tabs or the like. The locking tabs can be provided on the proximal housing portion or on the tubular body portion. The tubular body portion would include a grasping flange for enabling a robotic manipulator to grasp and move the abdominal port during a surgical procedure.

Alternatively, in this embodiment, the first access port includes a proximal housing portion that is adapted to be selectively coupled with the tubular body portion thereof, wherein the tubular body portion is of a proprietary design, or wherein the tubular body portion is of a non-proprietary design.

25

In accordance with a preferred embodiment of the subject invention, the proximal housing portion includes a manifold defining the gas inlet path and the gas outlet path for the access port. Preferably, the inlet and outlet paths are concentrically  
5 arranged within the manifold, and the dual lumen portion of the tube set includes a coaxial connector for coupling with the manifold. Alternatively, the inlet and outlet paths are arranged in parallel within the manifold, and the dual lumen portion of the tube set includes a suitable connector for coupling with the manifold. In comparison, the single lumen portion of the tube set can include a luer type connector for coupling  
10 with a conventional luer type fitting associated with the inlet path of the second access port.

The system further includes a gas recirculation apparatus including a pump having an outlet for delivering pressurized gas to the tube set and an inlet for receiving depressurized gas from the return line of the tube set through the filter cartridge  
15 assembly. The apparatus is also configured to deliver insufflation gas to the gas supply and sensing line of the tube set from a gas source, as disclosed, for example, in commonly assigned U.S. Patent No. 9,375,539. In accordance with a preferred embodiment of the subject invention, the gas recirculation apparatus may include a programmable controller with software that is adapted and configured to detect the  
20 presence of the bifurcated multi-lumen tube set and is able to differentiate it from a different type tube set.

The subject invention is also directed to a new and useful surgical access port for performing an endoscopic surgical procedure in a surgical cavity of a patient, which includes a proximal housing portion and an elongated tubular body portion extending  
25 distally from the proximal housing portion and defining a central cannula or bore. The

proximal housing portion has an inlet path for communicating with a pressurized gas line of a tube set and an outlet path for communicating with a return gas line of the tube set. The proximal housing portion accommodates an annular jet assembly for receiving pressurized gas from the inlet path and for generating a gaseous sealing zone within the central cannula of the body portion to maintain a stable pressure within the surgical cavity of the patient.

The subject invention is also directed to new and useful multi-lumen tube set for performing an endoscopic surgical procedure in a surgical cavity of a patient, which includes a multi-path filter cartridge assembly, a dual lumen portion communicating with the filter cartridge assembly and having a pressurized gas line and a return gas line for facilitating gas recirculation relative to the surgical cavity of the patient, and a single lumen portion communicating with the filter cartridge assembly and having a gas supply and sensing line for delivering insufflation gas to the surgical cavity of the patient and for periodically sensing pressure within the surgical cavity of the patient. Preferably, the dual lumen portion of the tube set includes a unique coaxial connector, and the single lumen portion of the tube set can include a conventional luer type connector.

The subject invention is also directed to a novel method of retrofitting a separable two-part valve sealed surgical access port to perform an endoscopic surgical procedure in a surgical cavity of a patient. The method includes the step of obtaining a separable two-part surgical access port having a valve sealed proximal housing portion that is detachably engaged to a single lumen tubular body portion.

The method further includes the steps of detaching the valve sealed proximal housing portion from the single lumen tubular body portion and then attaching a gas sealed proximal housing portion to the single lumen tubular body portion, wherein the

tubular body portion may be configured for manipulation by a robotic surgical system. The method further includes the step of connecting the gas sealed proximal housing portion to a source of pressurized gas for generating a gaseous sealing zone within a central cannula of the single lumen tubular body portion to maintain a stable pressure  
5 within the surgical cavity of the patient.

The subject invention is also directed to a method of retrofitting a reusable portion of a separable two-part valve sealed surgical access port to perform an endoscopic surgical procedure in a surgical cavity of a patient. The method includes the step of obtaining a reusable portion of a surgical access port normally having a  
10 valve sealed proximal housing portion that is detachably engaged to a reusable single lumen tubular body portion.

The method further includes the steps of attaching a gas sealed proximal housing portion to the reusable single lumen tubular body portion, wherein the reusable tubular body portion may be configured for manipulation by a robotic surgical system. The  
15 method further includes the step of connecting the gas sealed proximal housing portion to a source of pressurized gas for generating a gaseous sealing zone within a central cannula of the reusable single lumen tubular body portion to maintain a stable pressure within the surgical cavity of the patient.

The subject invention is also directed to a gas sealed access port for performing  
20 an endoscopic surgical procedure in a surgical cavity of a patient, and more particularly, for performing a robotically assisted single incision laparoscopic surgical procedure. This gas sealed access port includes a proximal housing having a central lumen providing gas sealed access to the surgical cavity, an inlet path for communicating with a source of pressurized gas, a tapered neck portion and an interior  
25 cavity accommodating an annular jet assembly for receiving pressurized gas from the

inlet path to generate a gaseous seal within the tapered neck portion to maintain a stable pressure within the surgical cavity, and an elongated tubular body extending from the tapered neck portion of the proximal housing in communication with the central lumen and including a flexible proximal body portion and a rigid distal body portion.

5           In accordance with a preferred embodiment of the subject invention, a distal end portion of the tapered neck portion of the proximal housing is dimensioned for insertion into a proximal end portion of the flexible proximal body portion, and the distal end portion of the tapered neck portion of the proximal housing has an exterior annular shoulder for limiting the insertion of the distal end portion of the tapered neck portion  
10 into the proximal end portion of the flexible proximal body portion.

          In addition, a proximal end portion of the rigid distal body portion is dimensioned for insertion into a distal end portion of the flexible proximal body portion, and the proximal end portion of the rigid distal body portion has an exterior annular ring for limiting the insertion of the proximal end portion of the rigid distal  
15 body portion into the distal end portion of the flexible proximal body portion. Also, a distal end portion of the rigid distal body portion has an exterior flared annular barb to inhibit withdrawal of the access port from the surgical cavity. The exterior annular ring and the exterior flexible bard also serve to anchor the access port with respect to a gel port or tissue, depending upon the surgical procedure with which it is used.

20           Preferably, the proximal end portion of the rigid distal body portion has an interior annular landing for interfacing with an exterior annular shoulder on an obturator shaft inserted into the central lumen of the proximal housing. In one embodiment of the invention, the flexible proximal body portion of the tubular body has a bendable tubular configuration. In another embodiment of the subject invention,

the flexible proximal body portion of the tubular body has a bendable and extensible accordion configuration.

These and other features of the gas circulation system and the single lumen gas sealed access device of the subject invention will become more readily apparent to  
5 those having ordinary skill in the art to which the subject invention appertains from the detailed description of the preferred embodiments taken in conjunction with the following brief description of the drawings.

**BRIEF DESCRIPTION OF THE DRAWINGS**

So that those skilled in the art will readily understand how to make and use the gas circulation system and gas sealed abdominal access devices of the subject invention without undue experimentation, preferred embodiments thereof will be described in  
5 detail herein below with reference to the figures wherein:

Fig. 1 is a perspective view of the gas circulation system of the subject invention in use during the performance of a laparoscopic surgical procedure, wherein the gas circulation system includes a multi-lumen filtered tube set having a dual lumen portion connected to a single lumen gas sealed access port configured for maintaining  
10 a stable pneumoperitoneum within the abdominal cavity of the patient and for facilitating smoke evacuation from the abdominal cavity, and a single lumen portion connected to a single lumen valve sealed access port configured for insufflation and abdominal pressure sensing;

Fig. 2 is a perspective view of the gas circulation system shown in Fig. 1,  
15 including a filter cartridge assembly, and a multi-lumen filtered tube set having a dual lumen portion connected to a single lumen gas sealed access port and a single lumen portion connected to a single lumen valve sealed access port;

Fig. 3 is a perspective view of the multi-lumen filtered tube set of the subject invention, wherein a conventional luer connector is associated with the single lumen  
20 portion of the tube set and a dual lumen connector with concentric flow passages is associated with the dual lumen portion of the tube set;

Fig. 3A is a perspective view on another multi-lumen tube set of the subject invention, wherein the dual lumen portion is bifurcated and each of the tubes has a separate connector;

Fig. 4 is an enlarged localized perspective view of the tube fitting on the filter cartridge assembly shown in Fig. 3, with parts separated for ease of illustration;

Fig. 5 is a perspective view of a single lumen gas sealed access port constructed in accordance with a preferred embodiment of the subject invention;

5 Fig. 5A is a perspective view of the housing portion of a single lumen gas sealed access port similar to the embodiment of Fig. 5, but with a different manifold arrangement of the inlet and outlet paths;

Fig. 6 is an exploded perspective view the single lumen gas sealed access port shown in Fig. 5, with parts separated for ease of illustration;

10 Fig. 7 is a perspective view of the annular jet assembly shown in Fig 6, with parts separated for ease of illustration;

Fig. 8 is a cross-sectional view of the single lumen gas sealed access port, taken along line 8-8 of Fig. 5, illustrating the interior of the proximal housing portion that accommodates an annular jet assembly shown in Fig. 7, which generates a gaseous  
15 sealing zone within the central bore of the cannula to maintain stable pressure within the surgical cavity of a patient;

Fig. 9 is an enlarged localized view of the distal end portion of the single lumen gas sealed access port of Fig. 5, which has an outer diameter  $D_2$ ;

20 Fig. 10 is an enlarged localized view of the distal end portion of a prior art dual lumen gas sealed access port, which has an outer diameter  $D_1$ ;

Fig. 11 is a perspective view of a single lumen gas sealed trocar constructed in accordance with a preferred embodiment of the subject invention which has a slotted or louvered end cap configured for air entrainment and emergency pressure relief, without permitting instrument access to the central bore of the cannula;

Fig. 12 is a top plan view of the single lumen gas sealed trocar shown in Fig. 11;

Fig. 13 is a perspective view of another embodiment of a single lumen gas sealed trocar as in Fig 11, which has a non-linear tubular body portion;

5 Fig. 14 is a perspective view of another embodiment of a single lumen gas sealed trocar constructed in accordance with the subject invention which is configured for air entrainment and emergency pressure relief, without permitting instrument access through the central bore of the cannula, wherein the trocar includes a closed obturator tip to prevent passage of an instrument through the cannula into the surgical cavity;

10 Fig. 15 is an exploded perspective view of the gas sealed trocar of Fig. 14, with parts separated for ease of illustration;

Figs. 16 and 17 are perspective views of another embodiment of a single lumen gas sealed trocar constructed in accordance with the subject invention, wherein the trocar includes a tubular body portion with a central cannula or bore that is  
15 dimensioned to prevent instrument passage therethrough, while permitting access to an obturator;

Fig. 18 is a side elevational view of another embodiment of a single lumen gas sealed trocar constructed in accordance with the subject invention, wherein the trocar includes a tubular body portion with an elliptical cross-section that is shaped to prevent  
20 instrument passage therethrough, while permitting access to an obturator, and also including an adhesive pad for retention purposes;

Fig. 19 is a perspective view of the single lumen gas sealed trocar shown in Fig. 18, during introduction of the obturator;

Fig. 20 is a cross-sectional view of the body portion of the trocar taken along  
25 line 20-20 of Fig. 19;

Figs. 21-24 illustrate yet another embodiment of a single lumen gas sealed trocar constructed in accordance with the subject invention which is configured for air entrainment and emergency pressure relief, without permitting instrument access to the central bore of the cannula, wherein the trocar includes a mechanically actuated slotted or louvered end cap that is mounted to move into a closed and locked position when an  
5 obturator is removed from the device;

Fig. 25 is a perspective view of a gas circulation system constructed in accordance with the subject invention that is adapted and configured for use during a robotically assisted surgical procedures, which includes a multi-lumen filtered tube set,  
10 a two-part single lumen gas sealed access port with a detachable housing portion and a two-part single lumen valve sealed access port with a detachable housing portion;

Fig. 26 is a perspective view of the single lumen gas sealed access port shown in Fig. 25, which includes a reusable distal cannula portion configured for robotic manipulation and a detachable housing portion configured for gaseous sealing, gas  
15 recirculation and smoke evacuation;

Fig. 27 is an exploded perspective view of the single lumen gas sealed access port of Fig. 26, with the housing portion separated from the reusable cannula or tubular body portion for ease of illustration;

Fig. 27A is an exploded perspective view of an alternative version of the single  
20 lumen gas sealed access port of Fig. 26, wherein the manifold includes parallel connectors as opposed to a concentric connector;

Fig. 28 is a side elevational view of the separable housing portion of the single lumen gas sealed access port of Fig. 26;

Fig. 29 is an exploded perspective view of the separable housing portion of the single lumen gas sealed access port of Fig. 26, with the component parts thereof separated for ease of illustration.

Fig. 30 is a cross-sectional view of the separable housing portion of the single lumen gas sealed access port taken along line 30-30 of Fig. 28;

Fig. 31 is a perspective view of a gas circulation system constructed in accordance with the subject invention that is adapted and configured for use during an endoscopic or laparoscopic surgical procedure, which includes a multi-lumen filtered tube set, a single lumen gas sealed access port with a detachable housing portion and a single lumen valve sealed access port with a detachable housing portion;

Fig. 32 is a perspective view of the single lumen gas sealed access port shown in Fig. 31, which includes a distal cannula portion and a detachable housing portion configured for gaseous sealing, gas recirculation and smoke evacuation;

Fig. 33 is an exploded perspective view of the single lumen gas sealed access port of Fig. 32, with the housing portion separated from the tubular body portion for ease of illustration;

Fig. 34 is an exploded perspective view of the separable housing portion of the single lumen gas sealed access port of Fig. 32, with the component parts thereof separated for ease of illustration; and

Figs. 35-38 illustrate the method steps involved in retrofitting a separable two-part valve sealed access port to perform an endoscopic surgical procedure in a surgical cavity of a patient, wherein:

Fig. 35 shows a separable two-part access port having a valve sealed proximal housing portion that is detachably engaged to a single lumen tubular body portion;

Fig. 36 shows detaching the valve sealed proximal housing portion from the single lumen tubular body portion of the access port;

Fig. 37 shows attaching a gas sealed proximal housing portion to the single lumen tubular body portion of the access port;

5 Fig. 38 shows the fully assembled single lumen gas sealed access port, as illustrated in Fig. 32.

Fig. 39 is an illustration of a robotically assisted single incision laparoscopic surgical procedure performed through gel port using single lumen gas sealed access ports having flexible/bendable tubular body portions that are configured to provide  
10 spatial separation between adjacent robotic arms;

Fig. 40 is a perspective view of single lumen gas sealed access ports having flexible/bendable tubular body portion constructed in accordance with a preferred embodiment of the subject invention, wherein an obturator is installed within the central lumen of the access port to maintain the bendable body portion in an unbent  
15 condition for percutaneous introduction to the surgical cavity;

Fig. 41 is a perspective view of the single lumen gas sealed access ports shown in Fig. 40, with the obturator removed from the central lumen of the access port, and illustrating the range of movement of the bendable body portion of the access port;

Fig. 42 is an exploded perspective view of the bendable single lumen gas sealed  
20 access ports shown in Fig. 41, with arts separated for ease of illustration;

Fig. 43 is a cross-sectional view of the bendable single lumen access port of the subject invention, taken along line 43-43 of Fig. 40;

Fig. 44 is a side elevational view of another embodiment of a flexible/bendable single lumen gas sealed access ports which includes a body portion that has a bendable  
25 and extensible accordion configuration, wherein an obturator is installed within the

central lumen of the access port to maintain the body portion in an unbent and extended condition for percutaneous introduction to the surgical cavity;

Fig. 45 is a side elevation view of the single lumen gas sealed access ports shown in Fig. 44, with the obturator partially withdrawn from the central lumen of the  
5 access port, and illustrating the body portion in an unbent and compressed condition;  
and

Fig. 46 is a side elevational view of the single lumen gas sealed access ports shown in Fig. 44, with the obturator removed from the central lumen of the access port,  
and illustrating the range of movement of the bendable and extensible body portion of  
10 the access port.

### **DETAILED DESCRIPTION OF THE PREFERRED EMBODIMENTS**

Referring now to the drawings wherein like reference numerals identify similar structural elements and features of the subject invention, there is illustrated in Fig. 1 a gas circulation system for performing an endoscopic surgical procedure in a surgical cavity of a patient, and more particularly, for performing a laparoscopic surgical procedure in the abdominal cavity of a patient that is constructed in accordance with a preferred embodiment of the subject disclosure and is designated generally by reference numeral 10.

The gas circulation system 10 is specifically designed to cooperate with a programmable multi-modal gas delivery system 12. The gas delivery system 12 is of the type described in commonly assigned U.S. Patent No. 9,375,539, the disclosure of which is herein incorporated by reference in its entirety. The gas delivery system 12 includes a graphical user interface 14 for setting operating parameters and a pump 16 for facilitating the recirculation of pressurized gas relative to the surgical cavity of the patient. The gas delivery system 12 is connected to a source of surgical gas 18 for delivering insufflation gas to the surgical cavity of the patient.

In brief, the gas circulation system 10 includes a multi-lumen filtered tube set 20 including a dual lumen portion 22 and a single lumen portion 24, a first gas sealed single lumen access port 26 operatively connected to the dual lumen portion 22 of the tube set 20 and a second valve sealed single lumen access port 28 operatively connected to the single lumen portion 24 of the tube set 20. Each of these components of the gas circulation system 10, and variations thereof, will be described in greater detail herein below.

### **The Multi-Lumen Tube Set**

Referring to Figs. 2-4, the gas circulation system 10 of the subject invention includes a multi-lumen filtered tube set designated generally by reference numeral 20 that includes a dual lumen portion 22 and a single lumen portion 24. The dual lumen  
5 portion 22 has a pressurized gas line 30 and a return gas line 32 for facilitating gas recirculation relative to the surgical cavity of the patient. The single lumen portion 24 has a gas supply and sensing line 34 for delivering insufflation gas to the surgical cavity of the patient and for periodically sensing pressure within the surgical cavity of the patient.

10 The tube set 20 is operatively associated with a multi-path filter cartridge assembly 36. More particularly, the gas lines of the tube set 20 extend from a fitting 38 on the end cap 40 of the filter cartridge assembly 36. A filter cartridge assembly of this type is disclosed for example in commonly assigned U.S. Patent No. 9,067,030 the disclosure of which is herein incorporated by reference in its entirety. The filter  
15 cartridge assembly 36 is preferably designed for a single use and is thereafter disposable. It is specifically designed to cooperate with the multi-modal gas delivery system 12, illustrated in Fig. 1 and described in commonly assigned U.S. Patent No. 9,375,539.

While not shown here, the filter cartridge assembly 36 includes a first filtered  
20 flow passage communicating with the pressurized gas line 30 of the dual lumen portion 22 of the tube set 20, a second filtered flow passage communicating with the return gas line 32 of the dual lumen portion 22 of the tube set 20, and a third filtered flow passage communicating with the gas supply and sensing line 34 of the single lumen portion 24 of the tube set 20.

As shown in Figs. 2, 3 and 3A, the single lumen portion 24 of the tube set 20 includes a standard luer type connector 44 for connecting to a luer connection 25 on the valve sealed access port 28. The dual lumen portion 22 of the tube set 20 includes a dual lumen manifold connector 42 with coaxial flow passages for mating with a dual lumen manifold connector 60 on gas sealed access portion 26. In a preferred embodiment of the subject invention, the dual lumen portion 22 of the tube set 20 is at least partially formed as a conjoined extrusion, as best seen in Fig. 4. Alternatively, as shown in Fig. 3A, the dual lumen portion 22 of tube set 20 can be distally bifurcated into two separated gas lines 30 and 32, each with a single connector for mating with a correspondingly configured access port manifold, as shown for example in Fig. 14.

#### **Single Lumen Gas Sealed Access Port**

With continuing reference to Figs. 1 and 2 in conjunction with Figs. 5-9, the circulation system 10 includes a gas sealed single lumen access port 26 that is adapted and configured to provide gas sealed access to the surgical cavity of a patient during an endoscopic surgical procedure. In this regard, access port 26 functions similar to the dual-lumen trocar assembly that is disclosed, for example, in commonly assigned U.S. Patent Nos. 7,854,724, the disclosure of which is herein incorporated by reference in its entirety. However, access port 26 differs significantly from the trocar assembly disclosed in U.S. Patent No. 7,854,724 in that it has only one central lumen.

The access port 26 of the subject invention does not have a second annular lumen surrounding the central lumen, as shown for example in the prior art Fig. 10. Thus, access port 26 is not capable of delivering insufflation gas to the surgical cavity of a patient, nor is it capable of sensing cavity pressure. Rather, access port 26 is configured to provide gas sealed instrument access while facilitating the maintenance

of stable cavity pressure and smoke evacuation from the surgical cavity. The access port 26 will be described in greater detail below with regard to Figs. 5 through 9.

Referring now to Figs. 5 through 9, there is illustrated in more detail the single lumen gas sealed access port 26 of the subject invention, which includes a proximal housing portion 50 and an elongated tubular body portion 52 extending distally from the proximal housing portion 50 and defining a central cannula 54. The proximal housing portion 50 of access port 26 has an inlet path 56 for communicating with the pressurized gas line 30 of the tube set 20 and an outlet path 58 for communicating with the return gas line 32 of the tube set 20.

More particularly, as best seen in Figs. 5 and 8, to manage gas flow in the access port 26, the proximal housing portion 50 includes a manifold 60 defining the inlet path 56 and the outlet path 58 which are concentrically arranged within the manifold 60. The dual lumen portion 22 of the tube set 20 includes the coaxial connector 42 for coupling with the manifold 60 of the proximal housing portion 50, as best seen in Fig. 2. A dual lumen coupled connection of this type is disclosed, for example, in Fig. 21 of commonly assigned U.S. Patent Application Publication 2017/0361084, the disclosure of which is incorporated herein by reference in its entirety. Alternatively, the single lumen gas sealed access port 26 could have a manifold 60 with two independent parallel connectors 56 and 58, as shown in Fig. 5A.

Referring to Figs. 6 and 8, the proximal housing portion 50 of access port 26 defines an interior chamber 62 to accommodate a two-part annular jet assembly 64, which is best seen in Fig. 7. An end cap 76 covers the interior chamber 62 and defines an entry path for the central cannula 54. The annular jet assembly 64 is adapted and configured to receive pressurized gas from the inlet path 56 and for generating a

gaseous or pneumatic sealing zone within the central cannula 54 of the tubular body portion 52 to maintain a stable pressure within the surgical cavity of the patient.

Referring to Fig. 7, the annular jet assembly 64 includes an upper jet ring 66 having a nozzle tube 68 and a lower jet ring 70 defining a nozzle seat 72 for receiving  
5 the nozzle tube 68. The upper jet ring 66 and lower jet ring 70 each has an O-ring 75 and they are joined together by a plurality of interfitting lugs 74. The annular jet assembly 64 is disclosed in great detail in commonly assigned U.S. Patent No. 8,795,223 and U.S. Patent Application Publication 2015/0025323, the disclosures of which are herein incorporated by reference in their entireties.

10 There are several advantages to employing the gas circulation system 10 of the subject invention as compared to a system that utilizes the gas sealed access port disclosed for example in U.S. Patent No. 8,795,223. In particular, with respect to the access port 26, by removing the need for both an inner and outer cannula, because of the use of a separate conventional cannula for insufflation and sensing, there is a  
15 significant reduction in the effective outer diameter of the tubular body of the access port 26.

Figs. 9 and 10 illustrate this comparison, wherein Fig. 10 shows the tubular body portion 55 and central bore 57 of a 5 mm dual lumen gas sealed access device constructed in accordance with the disclosure of U.S. Patent No. 8,795,223, which has  
20 an effective outer diameter  $D_1$  of about 11.05 mm, whereas Fig. 9 shows a 5 mm version of the single lumen gas sealed access device 26 of the subject invention, which has a tubular body portion 52 with an effective outer diameter  $D_2$ , for example, of about 8.97 mm. It should be understood that the respective central bores 54, 57 of body portions 52, 55 have the same inner diameters.

This significant difference in the effective outer diameter of the single lumen gas sealed access port 26 of the subject invention enables surgery with a smaller patient incision, while maintaining similar functionality (i.e., gaseous sealing for instrumentation, stable pneumoperitoneum and smoke evacuation). A smaller incision size can also lead to smaller or invisible scars for the patient, less pain or pain medication, easier wound closure for the surgeon, etc. In addition, the single lumen gas sealed access port 26 of the subject invention uses less plastic and has fewer components than the gaseous sealed access port disclosed for example in U.S. Patent No. 8,795,223, and the single lumen design eliminates several mating features. This could allow for lower component and assembly costs, as well as more efficient product qualification.

Those skilled in the art will readily appreciate that the tubular body portion 52 of the access port 26 can be introduced into the abdominal cavity of a patient through the abdominal wall using an inserter or obturator. In this regard, as best seen in Figs. 5 and 8 the end cap 76 on the proximal housing 50 includes diametrically opposed flanges 78a and 78b which are designed to cooperate with an obturator or introducer of the type described and illustrated in commonly assigned U.S. Patent No. 9,545,264, the disclosure of which is herein incorporated by reference in its entirety. Other types of obturators or introducers could also be utilized for this purpose.

20

### **Single Lumen Gas Sealed Trocar Without Instrument Passage**

Referring now to Figs. 11 through 24, while the single lumen gas sealed access port 26 described above is adapted and configured to perform gaseous sealing for surgical instrumentation passing therethrough, stable cavity pressure and smoke  
5 evacuation of the surgical cavity, as well as being constructed to permit air entrainment and emergency relief of cavity pressure, it is also envisioned and well within the scope of the subject disclosure that an embodiment of the subject invention does not necessarily have to provide instrument access to the surgical cavity, but rather it can be configured as a single lumen gas sealed trocar without an instrument passage.

10 For example, there is illustrated in Figs. 11 and 12, a gas sealed trocar 126 that is adapted and configured to maintain stable cavity pressure and effect smoke evacuation of a surgical cavity, as well as permit air entrainment and emergency pressure relief, by way of a concentric dual lumen manifold 160, but without permitting instrument access into and through the central cannula bore 154 of the body portion  
15 152. In this regard, the central bore 154 of the gas sealed trocar 126 is covered by a louvered end cap 176 on housing portion 150 that includes a set of spaced apart slots 180, which physically prevent or otherwise block instrument access into and through the central bore 154 of the trocar 126.

Because surgical instruments are not inserted into this gas sealed trocar 126, the  
20 inside diameter (and therefore the outside diameter of the device) can be reduced significantly without sacrificing gaseous sealing functionality, as shown for example in Figs.16-17, described in more detail below. This can further increase the potential size-based advantages of the port of the subject invention. A gas sealed trocar of this type can have many alternative embodiments. For example, shown in Figs. 18-20 and later  
25 described, the trocar device could include a thinner and/or flatter channel or an oblong

channel, since the conduit does not have to be cylindrical in order to provide a gaseous seal around cylindrical surgical instruments. This design may allow for clinical advantages as the elliptical or oblong geometry of this embodiment aligns more closely with the linear skin incision made by the surgeon and therefore may provide for easier  
5 insertion and less trauma to the tissue surrounding the incision.

The trocar device also does not have to include a straight or longitudinal pathway. For example, as shown in Fig. 13, a gas sealed trocar 226 with a proximal housing portion 250 having a louvered end cap 176 and bi-lumen manifold 260 could include a non-linear body portion 252 that is configured to bend 90 degrees from its  
10 axis. This construction allows for a number of improvements such as anchoring to a patient's abdominal wall during a laparoscopic surgical procedure, providing enhanced or user-directed smoke evacuation range and coverage, and eliminating clutter within the working space both inside and outside of the abdominal cavity.

Referring now to Figs. 14-15, there is illustrated a gas sealed trocar 326 for  
15 performing an endoscopic surgical procedure in a surgical cavity of a patient, which includes a proximal housing portion 350 and an elongated single lumen tubular body portion 352 extending distally from the proximal housing portion 350 and defining a central cannula 354. The proximal housing portion 350 has an inlet path 356 for communicating with a pressurized gas line 30 of a tube set 20 and an outlet path 358  
20 for communicating with a return gas line 32 of the tube set 20. The proximal housing portion 350 includes a manifold 360 defining the inlet path and the outlet path, wherein the inlet and outlet paths are arranged in parallel within the manifold 360.

Alternatively, paths 356 and 358 could be formed in a manner that is integral with the proximal housing portion 350, without requiring a separate manifold.

The proximal housing portion 350 accommodates an annular jet assembly 364 for receiving pressurized gas from the inlet path 356 and for generating a gaseous sealing zone within the central cannula 354 of the tubular body portion 352 to maintain a stable pressure within the surgical cavity of the patient, wherein the proximal housing portion 350 is adapted and configured to permit air entrainment, but the body portion 352 is closed off to prevent access through the central cannula 354 into the surgical cavity, as described further below.

The proximal housing portion 350 includes a manifold 360 defining the inlet path and 356 the outlet path 358, wherein the inlet and outlet paths are arranged in parallel within the manifold 360. The proximal housing portion 350 also includes suture securement tangs 394 to facilitate securement of the device 326 during a surgical procedure. The proximal housing portion 350 further includes an end cap 376 with circumferentially disposed radial slots 377 to permit air entrainment and emergency relief of cavity pressure. The end cap 376 is also configured with a central aperture 378 to receive a plug 390 for closing the central cannula 354 of the tubular body portion 352, and thereby prevent air entrainment, if the need arises.

A distal end section of the tubular body portion 352 forms a closed conical tip 355 for facilitating percutaneous introduction of the device. Moreover, the closed distal tip 355 prevents the passage of a surgical instrument into the patient's body cavity through the central cannula 354. The distal end section of the tubular body portion 352 includes a plurality of apertures 392 for facilitating gas/fluid communication between the central cannula 354 of the tubular body portion 352 and the surgical cavity of the patient.

Referring now to Figs. 16 and 17, there is illustrated a gas sealed trocar 426 for performing an endoscopic surgical procedure in a surgical cavity of a patient, which

includes a proximal housing portion 450 and an elongated single lumen tubular body portion 452 extending distally from the proximal housing portion 450 and defining a central cannula 454.

The proximal housing portion 450 includes an end cap 476 that permits air  
5 entrainment and a dual lumen manifold 460 defining the inlet path 456 and the outlet path 458, wherein the inlet and outlet paths are arranged in a concentric manner within the manifold 460, rather than in a parallel manner as shown in Fig. 14. The proximal housing portion 450 further includes suture securement tangs 494.

In this embodiment, the tubular body portion 452, and more particularly the  
10 central bore or cannula 454 is dimensioned to prevent the passage of a surgical instrument therethrough. For example, the bore 454 could be dimensioned to prevent the introduction of a standard 5 mm endoscopic surgical device commonly used during laparoscopic surgery. Thus, the inner diameter “d” of bore 454 would be less than 5 mm. However, in such an instance, the obturator or introducer 490 would be  
15 dimensioned to pass through the central bore 454 to facilitate the percutaneous introduction of the trocar 426.

Referring now to Figs. 18-20, there is illustrated a gas sealed trocar 526 for performing an endoscopic surgical procedure in a surgical cavity of a patient, which includes a proximal housing portion 550 and an elongated single lumen tubular body  
20 portion 552 extending distally from the proximal housing portion 550 and defining a central cannula 554. The proximal housing portion 550 includes a manifold 560, wherein the inlet and outlet paths are arranged in a parallel manner.

As best seen in Fig. 20, the tubular body portion 552 has a non-circular cross-sectional configuration. More particularly, as shown in Fig. 20, the tubular body  
25 portion 552 has an elliptical cross-sectional configuration. Also, an adhesive pad 598

is operatively associated with the tubular body portion 552 for retaining the trocar 500 in place during a surgical procedure.

Referring now to Figs 21-24, there is illustrated another embodiment of a single lumen gas sealed trocar constructed in accordance with the subject invention, which is designated generally by reference numeral 626. Gas sealed trocar 626 includes a proximal housing portion 650 and an elongated single lumen tubular body portion 652 extending distally from the proximal housing portion 650 and defining a central cannula 654. The proximal housing portion 650 includes a manifold 660, wherein the inlet and outlet paths are arranged in a parallel manner.

The proximal housing portion 650 further includes a hinged end cap 676 that is mechanically actuated and mounted to move from an open position shown in Figs. 21-23 to a closed position shown in Fig. 24 upon the removal of an obturator 690 from the trocar 600 to prevent access to the central cannula 654. More particularly, the proximal housing portion 650 and the hinged end cap 676 are operatively connected to one another by biasing bands 675 that bias the end cap 676 into a normally closed position.

The end cap 676 has louvers or spaced apart slots 648 that permit air entrainment into the central cannula 654 and emergency relief of cavity pressure without permitting instrument access into and through the central cannula 654 of the tubular body portion 652. In addition, a locking mechanism 685 is provided on the proximal housing portion 650 for retaining the hinged end cap 676 in the closed position, as best seen in Fig. 24. More particularly, the locking mechanism 685 includes a pair of locking tabs 685a and 685b for capturing and retaining the flange 677 of the end cap 676.

**Separable Two-Part Single Lumen Gas Sealed Access Port for Robotic Surgery**

Referring to Figs. 25 through 30, there is illustrated another embodiment of the gas circulation system of the subject invention which is designated generally by reference numeral 710, and which is configured for use in robotically assisted minimally invasive surgical procedures. More particularly, the gas circulation system 710 is adapted for use in conjunction with a Da Vinci Xi type robotic system that is manufactured and sold by Intuitive Surgical, Inc.

Referring to Fig. 25, the gas circulation system 710 includes a multi-lumen tube set 20 having a dual lumen portion 22, a single lumen portion 24 and a multi-path filter cartridge assembly 36. The dual lumen portion 22 is adapted and configured to communicate with a separable two-part single lumen gas sealed access port designated generally by reference numeral 726. The single lumen portion 24 is adapted and configured to communicate with a separable two-part single lumen valve sealed access port designated generally by reference numeral 728.

Referring to Fig. 26, the gas sealed access port 726 is particularly configured for use in robotic surgery. It includes a proximal housing portion 750 that is adapted to be selectively coupled with a separate tubular body portion 752, as described in more detail below. The tubular body portion 752 is configured for manipulation by a robotic surgical system. More particularly, the proximal reception portion 755 of the tubular body portion 752 includes a radially outwardly extending grasping flange 757 for enabling a Da Vinci Xi type robotic manipulator (not shown) to grasp and move the abdominal port 750 during a minimally invasive surgical procedure.

With reference to Figs. 27-30, the proximal housing portion 750 of the gas sealed access port 726 includes a lower housing portion 751 dimensioned and

configured to be accommodated within the upper reception portion 755 of the tubular body portion 752. An O-ring 759 is provided within the upper reception portion 755 to seal against the exterior of lower housing portion 751. A tubular stem 753 extends through and from the lower housing portion 751 to communicate directly with the tubular bore or cannula 754 of the tubular body portion 752, when the two structures are attached together for use.

Referring to Fig. 30, the proximal housing portion 750 further includes an interior chamber to accommodate an annular jet assembly 764. The annular jet assembly 764 is configured to receive pressurized gas from the inlet path 756 and generate a gaseous or pneumatic sealing zone within the tubular stem 753. Because the tubular stem 753 is in pneumatic communication with the central cannula bore 754 of the tubular body portion 752, the device can maintain a stable cavity pressure and provide smoke evacuation.

With reference to Figs. 27 and 29, the proximal housing portion 750 of access port 726 is configured to be selectively or otherwise detachably coupled to the tubular body portion 752 by a pair of diametrically opposed spring-loaded locking tabs 740a and 740b. As best seen in Fig. 28, the separable housing portion 750 also includes a dual lumen manifold 760 to manage the flow of the pressure and return lines through concentric paths 756, 758. Alternatively, as shown in Fig. 27A, the manifold 760 could include parallel inlet and outlet paths 756 and 758.

### **Separable Two-Part Single Lumen Gas Sealed Access Port for Endoscopic**

#### **Surgery**

Referring now to Figs. 31 through 34, there is illustrated another embodiment of the gas circulation system of the subject invention which is designated generally by

reference numeral 810, which is adapted and configured for use in endoscopic surgical procedures. The system 810 includes a multi-lumen tube set 20 having a dual lumen portion 22, a single lumen portion 24 and a multi-path filter cartridge assembly 36.

Referring to Fig. 31, the dual lumen portion 22 of tube set 20 is adapted and  
5 configured to communicate with a two-part single lumen gas sealed access port designated generally by reference numeral 826, which includes a proximal housing portion 850 and a separable tubular body portion 852. The single lumen portion 24 of tube set 20 is adapted and configured to communicate with a two-part single lumen valve sealed access port designated generally by reference numeral 828, which includes  
10 a proximal housing portion 823 and a separable tubular body portion 825. Those skilled in the art will readily appreciate that the single lumen portion 24 of tube set 20 can be connected to a one-piece valve sealed access port, without departing from the spirit or scope of the subject invention.

Referring to Figs. 32 and 33, the gas sealed access port 826 includes a proximal  
15 housing portion 850 that is adapted to be selectively coupled with the upper reception portion 855 of tubular body portion 852. More particularly, the proximal housing portion 850 of the access port 826 is configured to be selectively coupled to the upper reception portion 855 of tubular body portion 852 by a pair of diametrically opposed spring-loaded locking tabs 840a and 840b operatively associated with the upper  
20 reception portion 855.

The separable housing portion 850 includes an end cap 876 and a dual lumen manifold 860 to manage the flow of the pressure and return lines. Housing portion 850 also has an interior chamber that accommodates an annular jet assembly 864 configured to generate a gaseous or pneumatic sealing zone within the central cannula

bore of the separable tubular body portion 852, to maintain a stable cavity pressure and provide smoke evacuation.

### **Method of Deploying a Single Lumen Two-Part Gas Sealed Access Port**

5 Referring to Figs. 35-38, the subject invention is also directed to a novel method of retrofitting a separable two-part valve sealed surgical access port to perform an endoscopic surgical procedure in a surgical cavity of a patient. As shown in Fig. 35, the method first includes the step of obtaining a separable two-part surgical access port 926 having a valve sealed proximal housing portion 950 that is detachably engaged to a  
10 single lumen tubular body portion 852. The proximal housing portion 950 includes a mechanical duckbill valve 995 and a conventional luer type fitting 925.

The method further includes the steps of detaching the valve sealed proximal housing portion 950 from the single lumen tubular body portion 852, as shown in Fig. 36, and then selectively attaching a gas sealed proximal housing portion 850 with  
15 manifold 860 to the single lumen tubular body portion 852, as shown in Fig. 37. Then, as shown in Fig. 38, the method further includes the step of connecting the gas sealed proximal housing portion 850 of the assembled port 826 to a source of pressurized gas for generating a gaseous sealing zone within a central cannula of the single lumen tubular body portion 852 to maintain a stable pressure within the surgical cavity of a  
20 patient.

### **Flexible Single Lumen Gas Sealed Access Port**

Referring now to Figs. 39-46, there is illustrated a flexible/bendable single lumen gas sealed access port for use in robotically assisted minimally invasive surgical  
25 procedures, which is designated generally by reference numeral 1000. More

particularly, the flexible/bendable gas sealed access port 1000 is adapted for use in conjunction with a Da Vinci Xi type robotic system 1010 during a robotically assisted single incision laparoscopic surgical procedure in a surgical cavity 1020 performed through a gel port 1030. In such a procedure, the bendable access ports 1000, which  
5 are each held in carriers 1050 on the end of each robot arm 1040, provide spatial separation between adjacent robotic arms 1040. This allows the arms 1040 of the robotic system 1010 to freely articulate past one another without interference, so as to prevent damage to the arms 1040 and any instruments held thereby.

Referring now to Figs. 40 through 43, the flexible/bendable single lumen gas  
10 sealed access port 1000 includes a proximal housing 1100 having a central lumen 1102 providing gas sealed access to the surgical cavity, an inlet path 1104 for communicating with a source of pressurized gas, and an outlet path 1105 for communicating with a source of suction. The housing 1100 has a tapered neck portion 1106 and an interior cavity 1108 accommodating an annular jet assembly 1110 ( see  
15 Fig. 7) for receiving pressurized gas from the inlet path 1104 to generate a gaseous seal within the tapered neck portion 1106 to maintain a stable pressure within the surgical cavity 1020 of a patient.

The flexible/bendable single lumen gas sealed access port 1000 further includes an elongated tubular body 1112 extending from the tapered neck portion 1106 of the  
20 proximal housing 1100 in communication with the central lumen 1102 and including a flexible proximal body portion 1114 and a rigid distal body portion 1116.

A distal end portion 1118 of the tapered neck portion 1106 of the proximal housing 1100 is dimensioned for insertion into a proximal end portion 1120 of the flexible proximal body portion 1114, and the distal end portion 1118 of the tapered  
25 neck portion 1106 of the proximal housing 1100 has an exterior annular shoulder 1122

for limiting the insertion of the distal end portion 1118 of the tapered neck portion 1106 into the proximal end portion 1120 of the flexible proximal body portion 1114.

In addition, a proximal end portion 1124 of the rigid distal body portion 1116 is dimensioned for insertion into a distal end portion 1126 of the flexible proximal body portion 1114, and the proximal end portion 1124 of the rigid distal body portion 1116 has an exterior annular ring 1128 for limiting the insertion of the proximal end portion 1124 of the rigid distal body portion 1116 into the distal end portion 1126 of the flexible proximal body portion 1114. Also, a distal end portion 1130 of the rigid distal body portion 1116 has an exterior flared annular barb 1132 to inhibit withdrawal of the access port 1000 from the surgical cavity 1020 during a surgical procedure.

In accordance with the subject invention, the exterior annular ring 1128 and the exterior flared annular barb 1132 act together as a stabilizer or anchor for the access port 1000. More particularly, when the access port 1000 is used with a gel port 1030, as shown in Fig. 39, the annular ring 1128 and the annular barb 1132 anchor the access port 1000 with respect to the gel port 1030. Alternatively, when the access port 1000 is used percutaneously, without a gel port, the annular ring 1128 and the annular barb 1132 will anchor the access port 1000 with respect to the tissue through which it passes (see Fig. 46).

As best seen in Fig. 43, the proximal end portion 1124 of the rigid distal body portion 1116 has an interior annular landing 1134 for interfacing with an exterior annular shoulder 1136 on an obturator shaft 1138 of an obturator 1140 inserted into the central lumen 1102 of the proximal housing 1100. When the obturator 1140 is installed, as best seen in Fig. 40, the flexible proximal body portion 1114 of tubular body 1112 is maintained in an unbent condition so that the access port can be percutaneously introduced into the surgical cavity. When the obturator 1140 is

completely removed from the central lumen 1102 of the access port 1000, as shown in Fig. 41, the flexible body portion 1114 of the tubular body 1112 can be readily bent to provide spatial separation between adjacent robotic arms 1040 of the robotic system 1010, which is shown in Fig. 39

5 Referring now to Figs 44 through 46, there is illustrated another flexible/bendable single lumen gas sealed access port for use in robotically assisted minimally invasive surgical procedures, which is designated generally by reference numeral 2000. In this embodiment of the subject invention, the flexible proximal body portion 2114 of the tubular body 2112 has a bendable and extensible accordion  
10 configuration. More particularly, as shown in Fig. 44, when an obturator 2140 having a shaft 2138 is installed within the central lumen 2102 of the housing 2100, the flexible body portion 2114 of the tubular body 2112 is maintained in an unbent and extended condition for percutaneous introduction to the surgical cavity of a patient.

As shown in Fig. 45, when the shaft 2138 of the obturator 2140 is at least  
15 partially withdrawn from the central lumen 2102 of the housing 2100 of access port 2000, the flexible body portion 2114 of the tubular body 2112 will assume a compressed condition. When the obturator 2140 is completely removed from the central lumen 2102 of the access port 2000, as shown in Fig. 46, the flexible body portion 2114 of the tubular body 2112 can be readily bent, while anchored to tissue by  
20 annular ring 2128 and annular barb 2132, to provide spatial separation between adjacent robotic arms 1040 of the robotic system 1010, which is shown in Fig. 39.

Those skilled in the art will readily appreciate that the flexible/bendable gas sealed access ports described above, and shown in Figs. 39-46, can be utilized in surgical procedures other than a robotically assisted single incision laparoscopic  
25 surgical procedure. For example, these devices could be used in robotically assisted

trans-anal surgical procedures such as TAMIS and TATmE. Furthermore, these flexible access ports can be used in conventional endoscopic procedures performed by surgeons without a robotic system.

While the gas circulation system, multi-lumen tube set and gas sealed access  
5 ports and trocars of the subject disclosure has been shown and described with reference to preferred embodiments, those skilled in the art will readily appreciate that changes and/or modifications may be made thereto without departing from the scope of the subject disclosure.

**WHAT IS CLAIMED IS:**

1. A gas sealed access port for performing an endoscopic surgical procedure in a surgical cavity of a patient, comprising:
  - 5 a) a proximal housing including a central lumen providing gas sealed access to the surgical cavity, an inlet path for communicating with a source of pressurized gas, a tapered neck portion and an interior cavity accommodating an annular jet assembly for receiving pressurized gas from the inlet path to generate a gaseous seal within the tapered neck portion to maintain a stable pressure within the  
10 surgical cavity; and
  - b) an elongated tubular body extending from the tapered neck portion of the proximal housing in communication with the central lumen and including a flexible proximal body portion and a rigid distal body portion.
- 15 2. A gas sealed access port as recited in Claim 1, wherein a distal end portion of the tapered neck portion of the proximal housing is dimensioned for insertion into a proximal end portion of the flexible proximal body portion.
- 20 3. A gas sealed access port as recited in Claim 2, wherein the distal end portion of the tapered neck portion of the proximal housing has an exterior annular shoulder for limiting the insertion of the distal end portion of the tapered neck portion into the proximal end portion of the flexible proximal body portion.

4. A gas sealed access port as recited in Claim 1, wherein a proximal end portion of the rigid distal body portion is dimensioned for insertion into a distal end portion of the flexible proximal body portion.

5 5. A gas sealed access port as recited in Claim 4, wherein the proximal end portion of the rigid distal body portion has an exterior annular ring for limiting the insertion of the proximal end portion of the rigid distal body portion into the distal end portion of the flexible proximal body portion.

10 6. A gas sealed access port as recited in Claim 1, wherein a distal end portion of the rigid distal body portion has an exterior flared annular barb to inhibit withdrawal of the access port from the surgical cavity.

15 7. A gas sealed access port as recited in Claim 1, wherein the proximal end portion of the rigid distal body portion has an interior annular landing for interfacing with an exterior annular shoulder on an obturator shaft inserted into the central lumen of the proximal housing.

20 8. A gas sealed access port as recited in Claim 1, wherein the flexible proximal body portion of the tubular body has a bendable tubular configuration.

9. A gas sealed access port as recited in Claim 1, wherein the flexible proximal body portion of the tubular body has a bendable and extensible accordion configuration.

25

10. A gas sealed access port as recited in Claim 1, wherein the proximal housing includes an outlet path for returning spent gas used to generate the gaseous seal in the tapered neck portion of the housing to a source of suction.

- 5 11. A gas sealed access port assembly for performing an endoscopic surgical procedure in a surgical cavity of a patient, comprising:
- a) a proximal housing including a central lumen providing gas sealed access to the surgical cavity, an inlet path for communicating with a source of pressurized gas, a tapered neck portion and an interior cavity accommodating an  
10 annular jet assembly for receiving pressurized gas from the inlet path to generate a gaseous seal within the tapered neck portion to maintain a stable pressure within the surgical cavity;
  - b) an elongated tubular body extending from the tapered neck portion of the proximal housing in communication with the central lumen and including  
15 a bendable proximal body portion and a rigid distal body portion; and
  - c) an obturator having an elongated shaft dimensioned and configured for insertion through the central lumen of the housing to introduce the access port into the surgical cavity while maintaining the bendable proximal body portion in an unbent condition.

20

12. A gas sealed access port as recited in Claim 11, wherein a proximal end portion of the rigid distal body portion has an interior annular landing for interfacing with an exterior annular shoulder formed on the elongated shaft of the obturator when the obturator is inserted into the central lumen of the proximal housing.

25

13. A gas sealed access port as recited in Claim 11, wherein a distal end portion of the tapered neck portion of the proximal housing is dimensioned for insertion into a proximal end portion of the flexible proximal body portion.

5 14. A gas sealed access port as recited in Claim 13, wherein the distal end portion of the tapered neck portion of the proximal housing has an exterior annular shoulder for limiting the insertion of the distal end portion of the tapered neck portion into the proximal end portion of the flexible proximal body portion.

10 15. A gas sealed access port as recited in Claim 11, wherein a proximal end portion of the rigid distal body portion is dimensioned for insertion into a distal end portion of the flexible proximal body portion.

15 16. A gas sealed access port as recited in Claim 15, wherein the proximal end portion of the rigid distal body portion has an exterior annular ring for limiting the insertion of the proximal end portion of the rigid distal body portion into the distal end portion of the flexible proximal body portion.

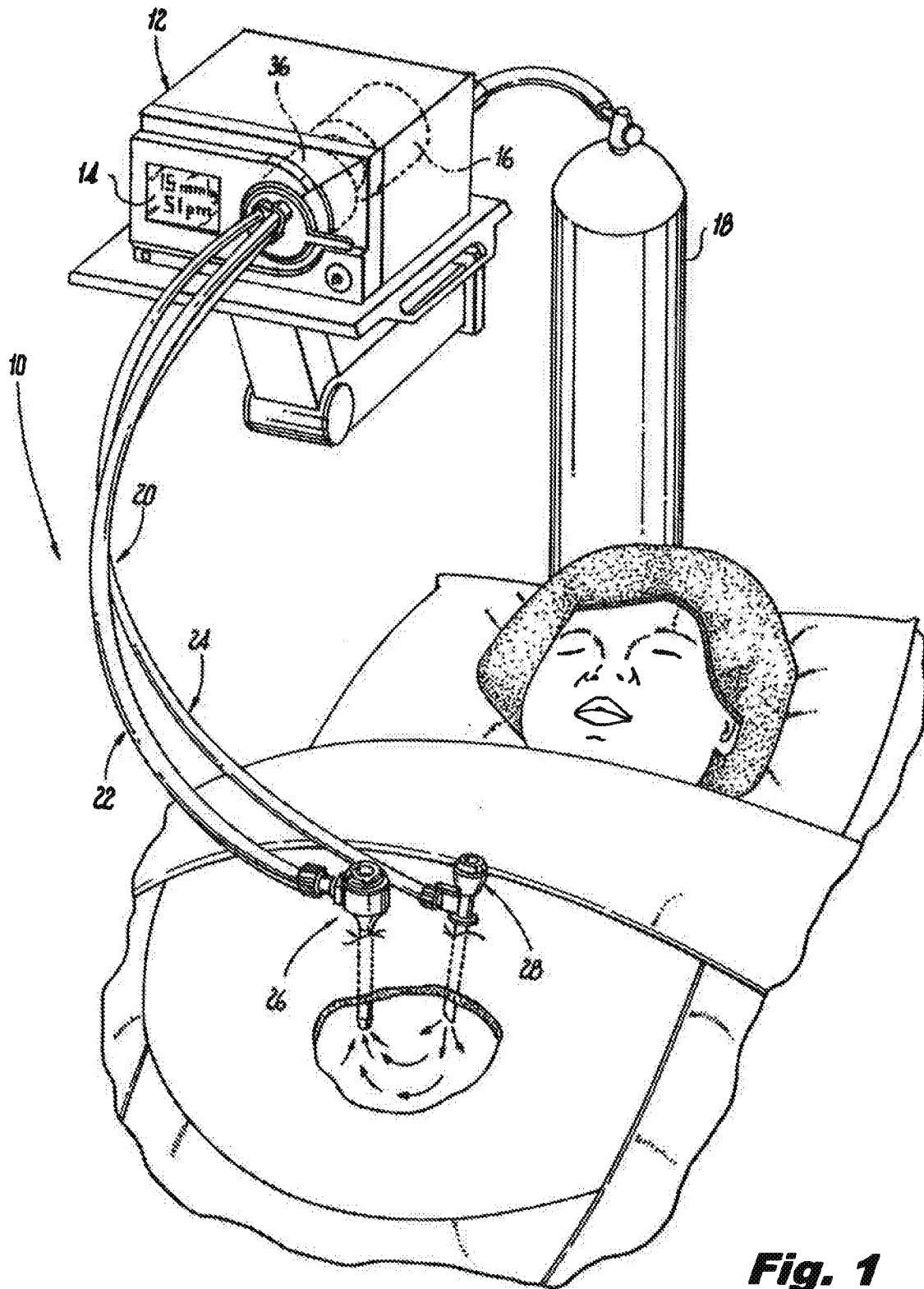
20 17. A gas sealed access port as recited in Claim 11, wherein a distal end portion of the rigid distal body portion has an exterior flared annular barb to inhibit withdrawal of the access port from the surgical cavity.

18. A gas sealed access port as recited in Claim 11, wherein the flexible proximal body portion of the tubular body has a bendable tubular configuration.

25

19. A gas sealed access port as recited in Claim 11, wherein the flexible proximal body portion of the tubular body has a bendable and extensible accordion configuration.

5           20. A gas sealed access port as recited in Claim 11, wherein the proximal housing includes an outlet path for returning spent gas used to generate the gaseous seal in the tapered neck portion of the housing to a source of suction.



**Fig. 1**

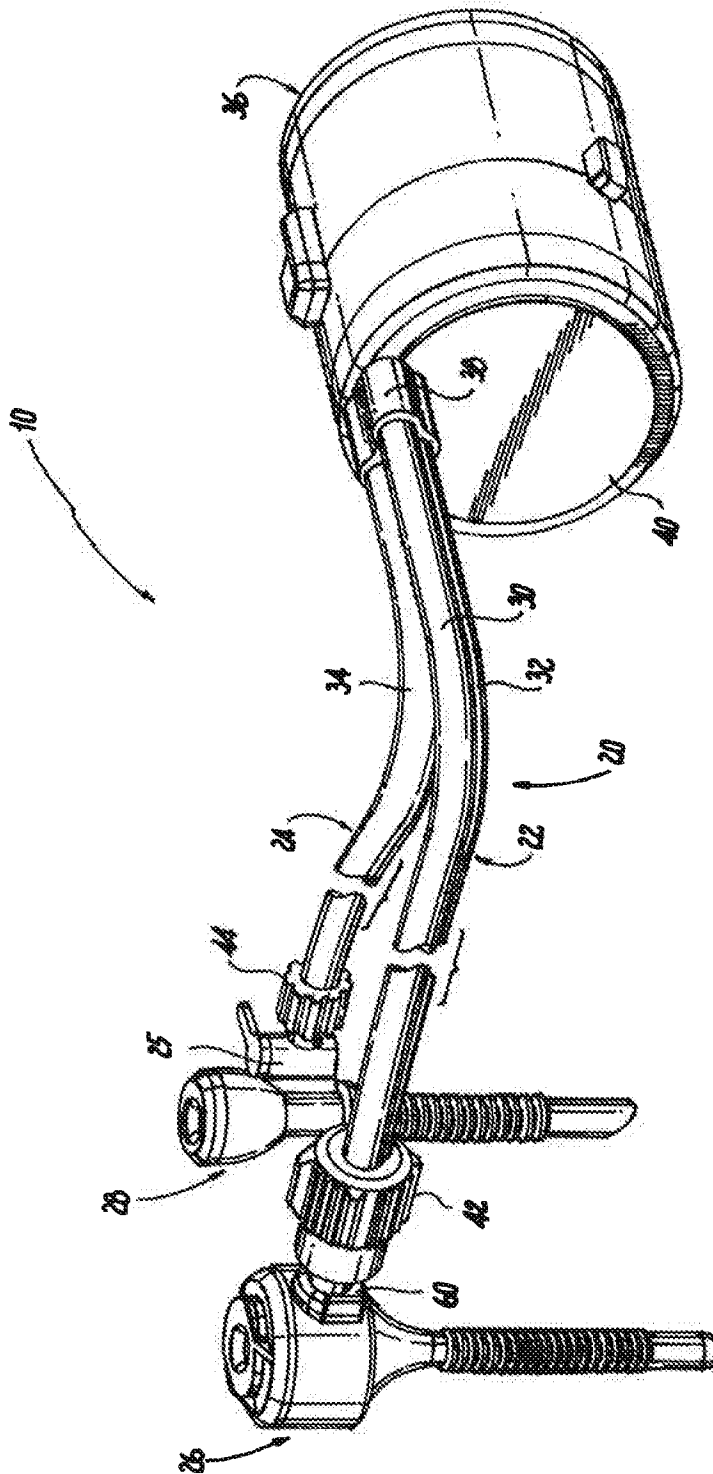
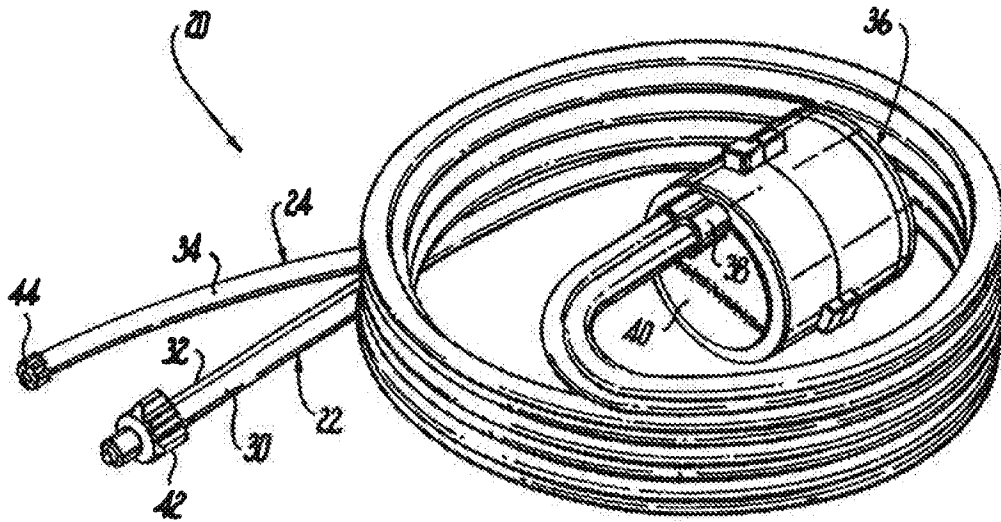
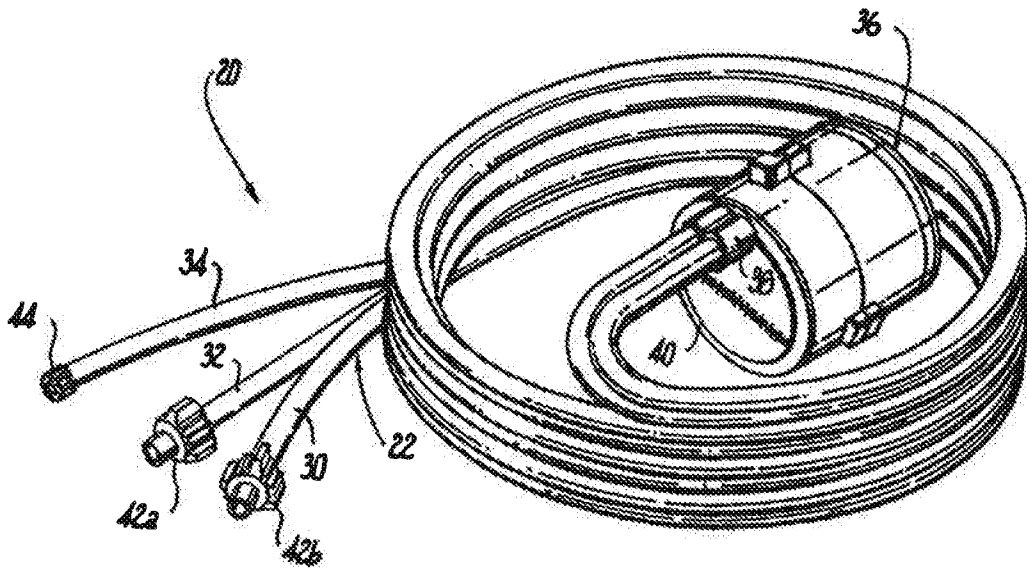


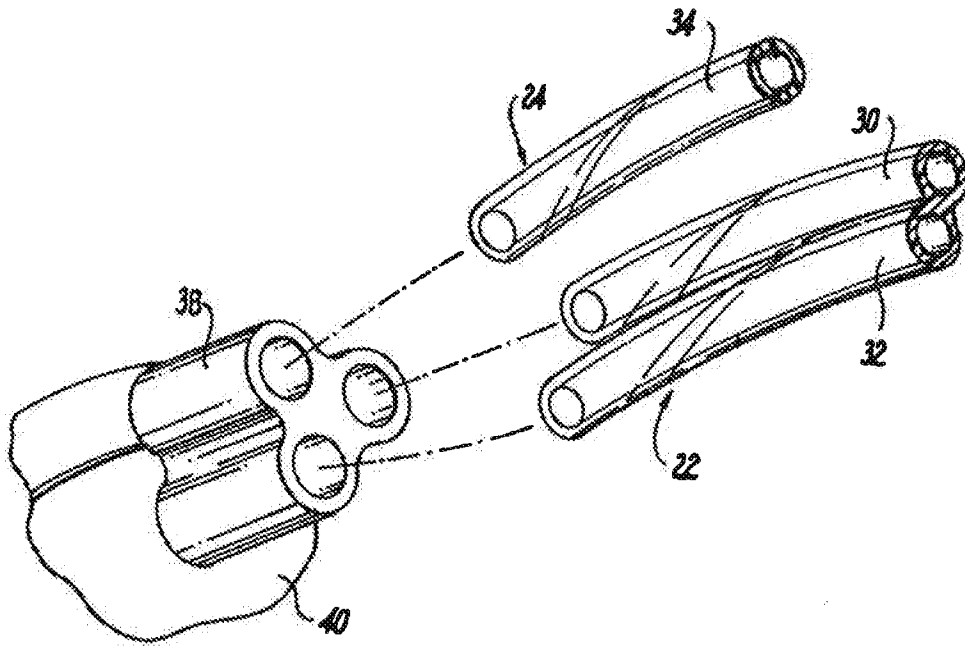
Fig. 2

**Fig. 3**



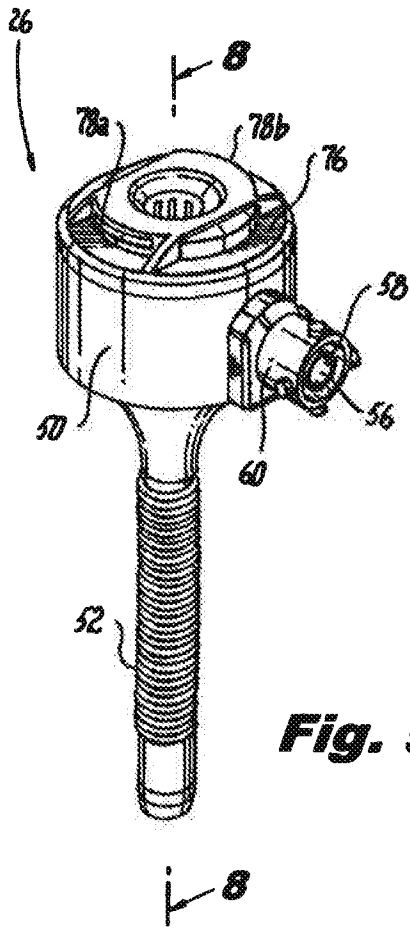
**Fig. 3A**



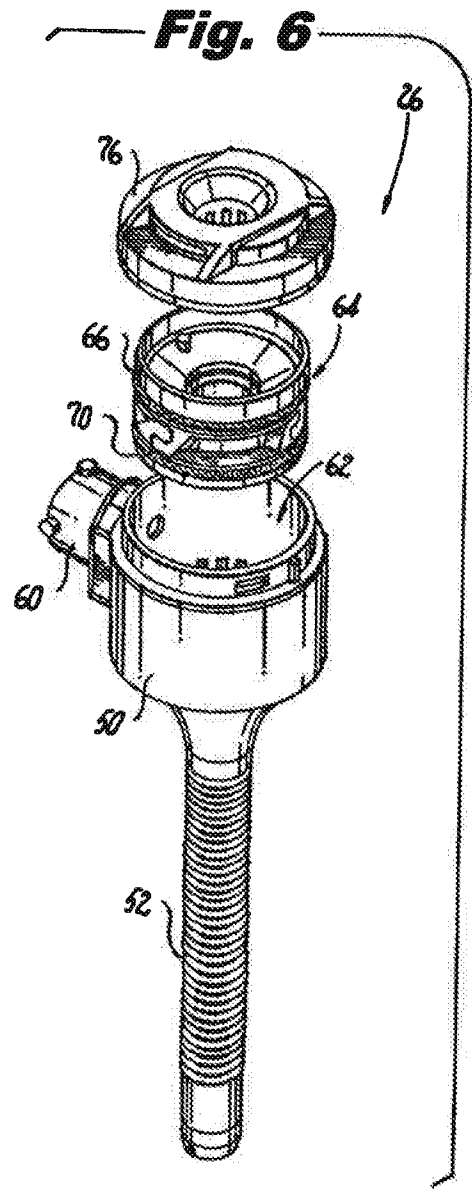


**Fig. 4**

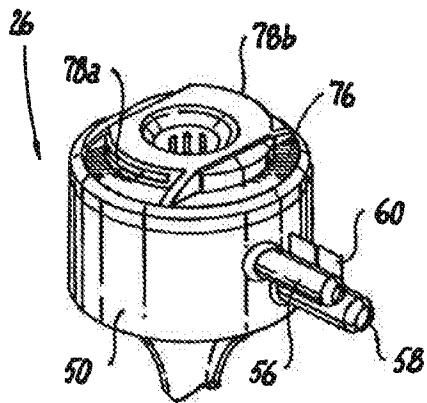
5/26



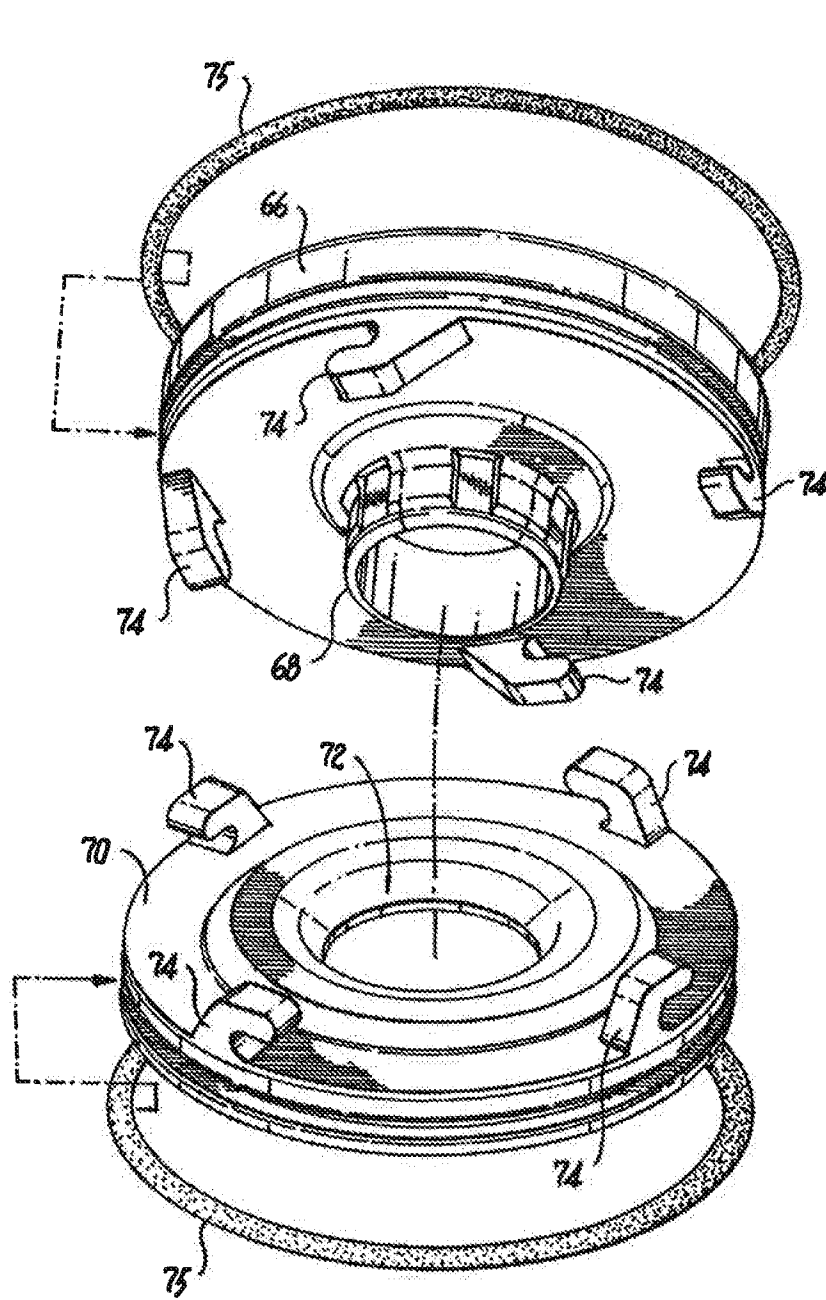
**Fig. 5**



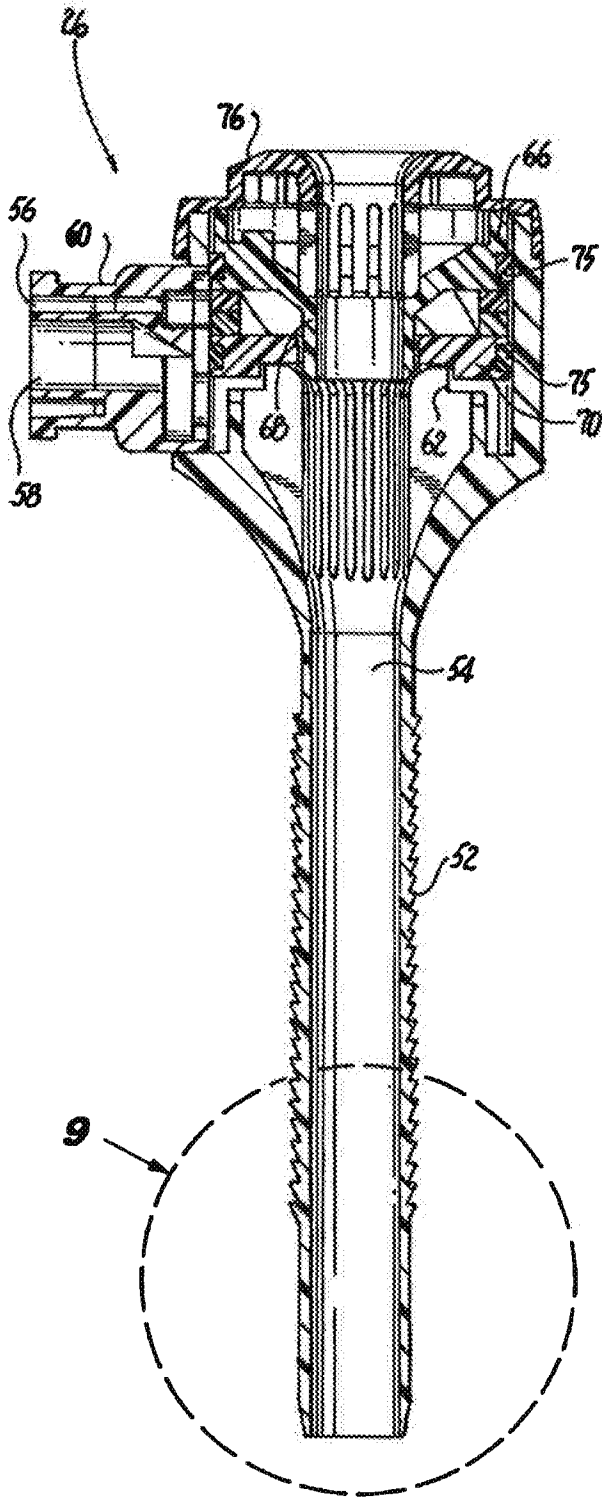
**Fig. 6**



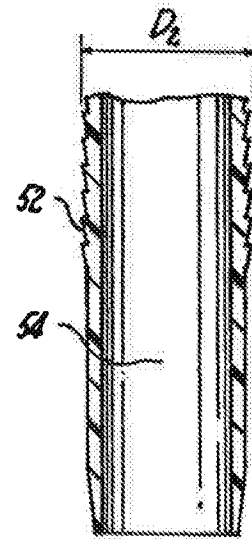
**Fig. 5A**



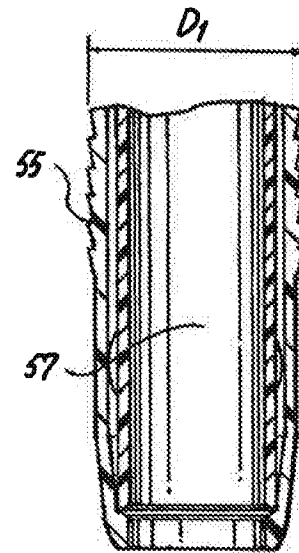
**Fig. 7**



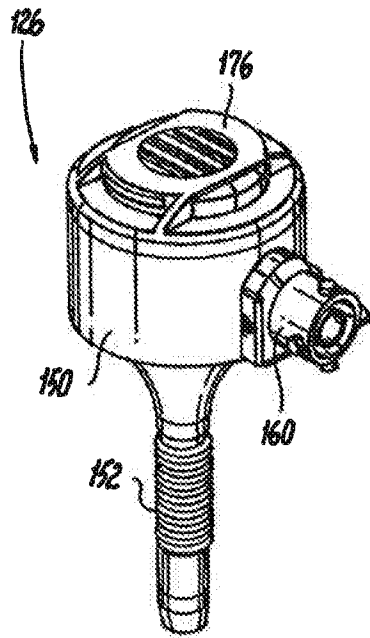
**Fig. 8**



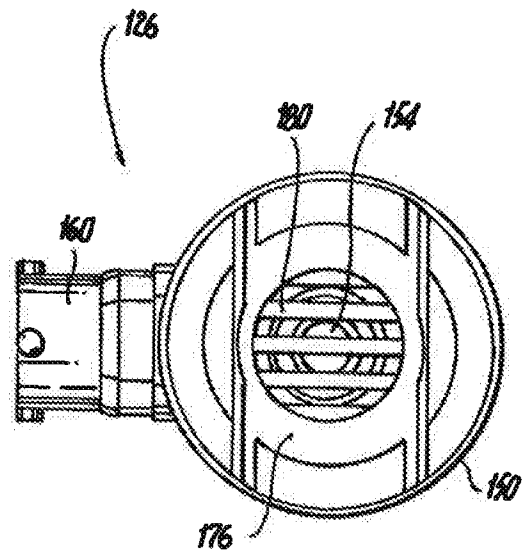
**Fig. 9**



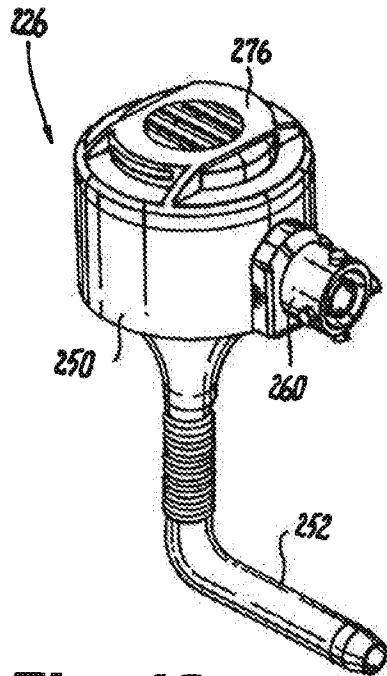
**Fig. 10  
(Prior Art)**



**Fig. 11**

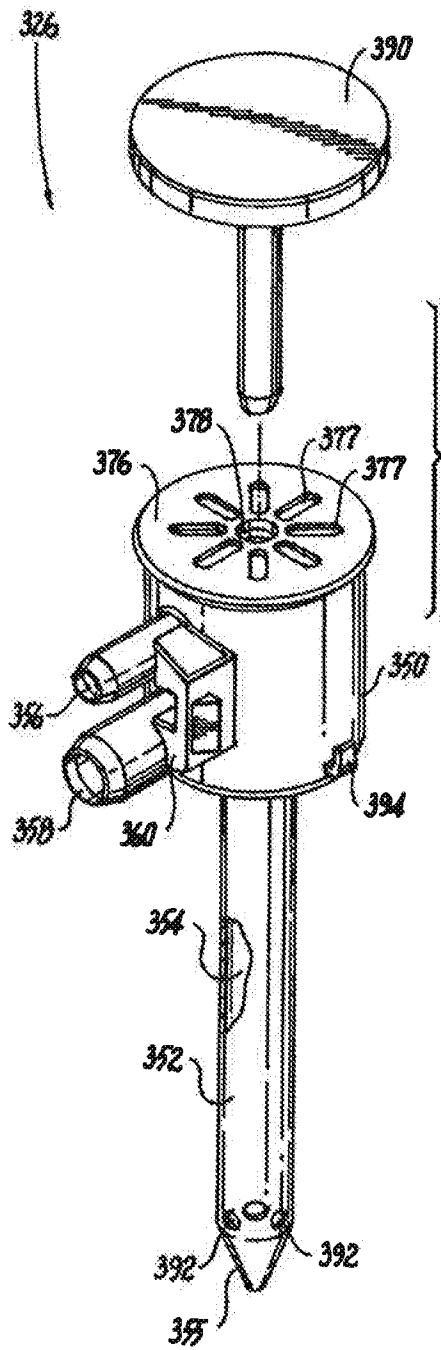


**Fig. 12**

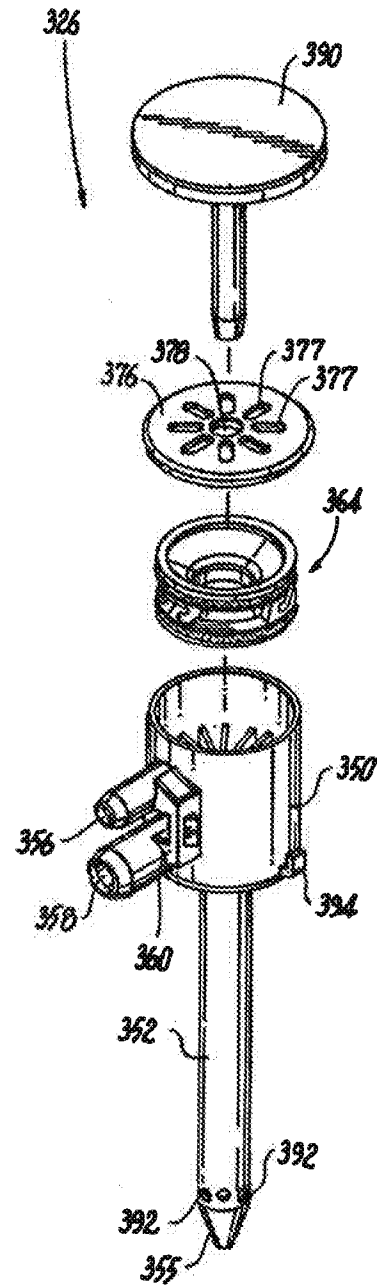


**Fig. 13**

9/26

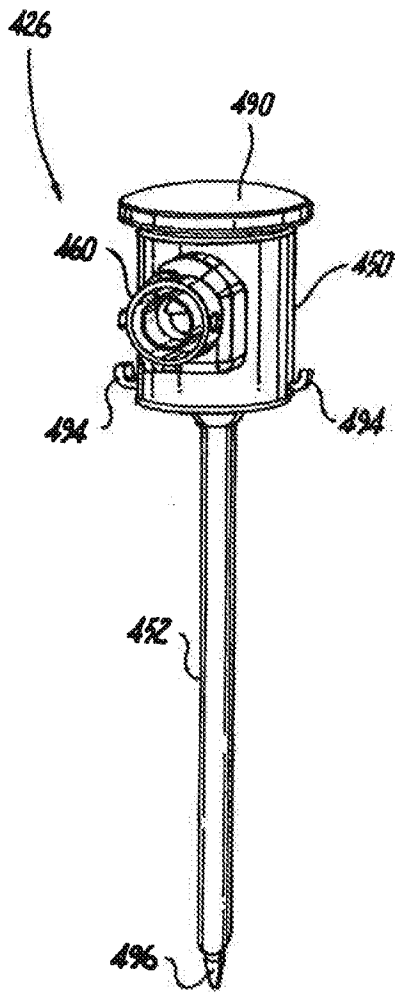


**Fig. 14**

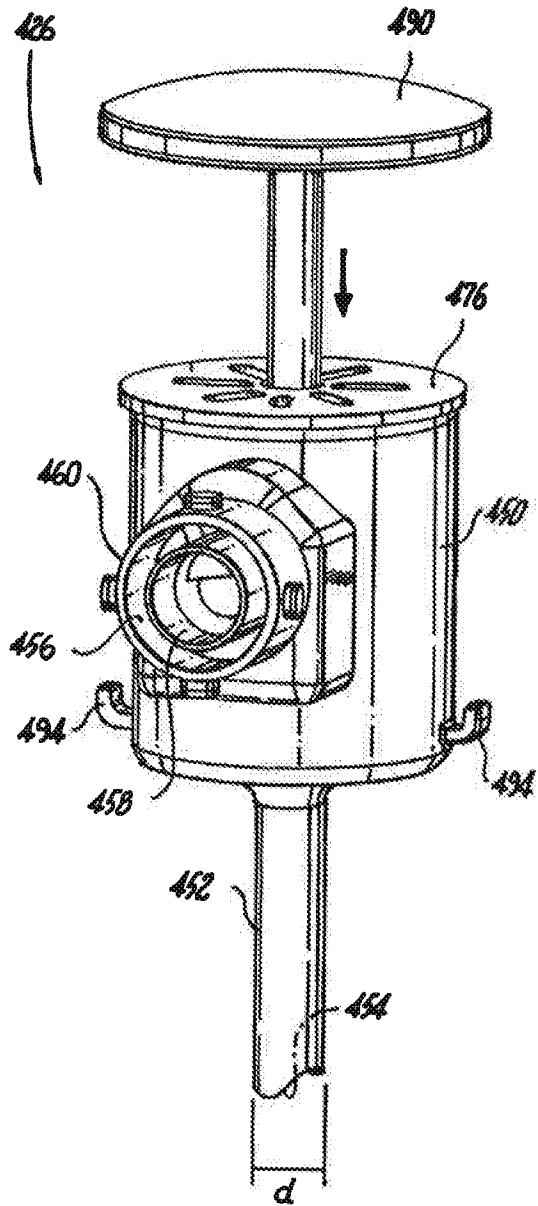


**Fig. 15**

10/26

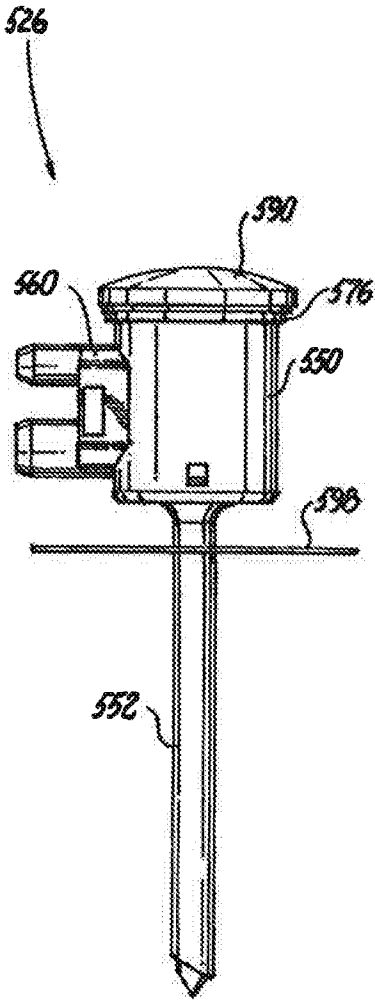


**Fig. 16**

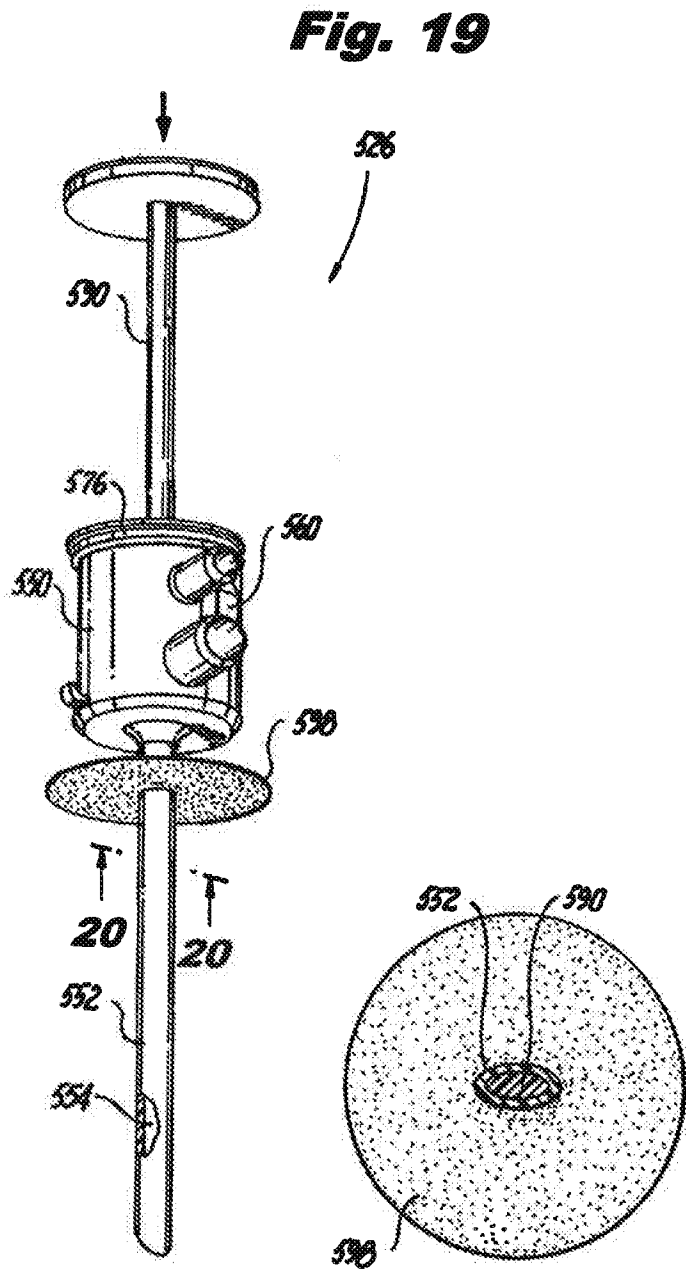


**Fig. 17**

11/26

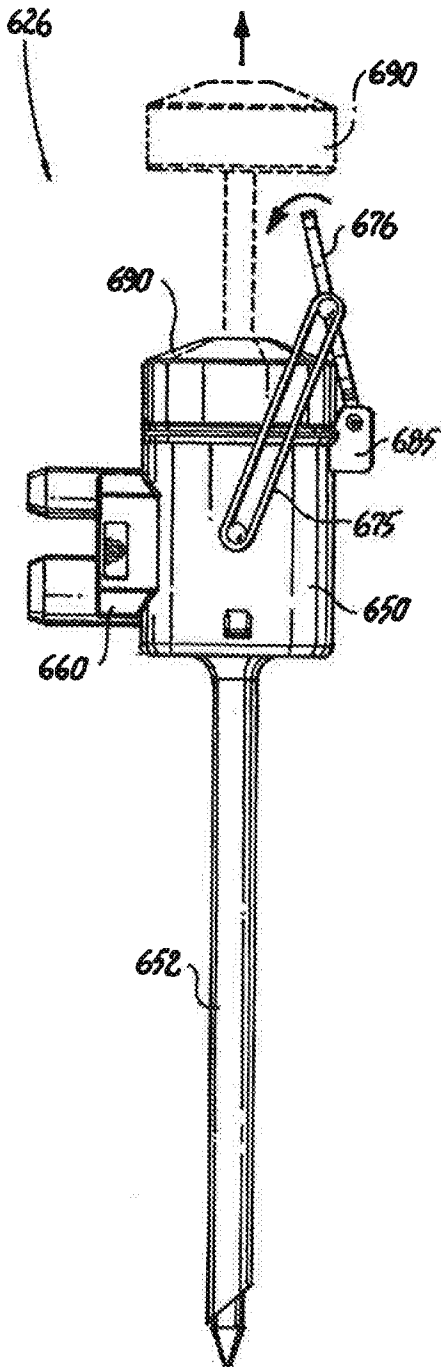


**Fig. 18**

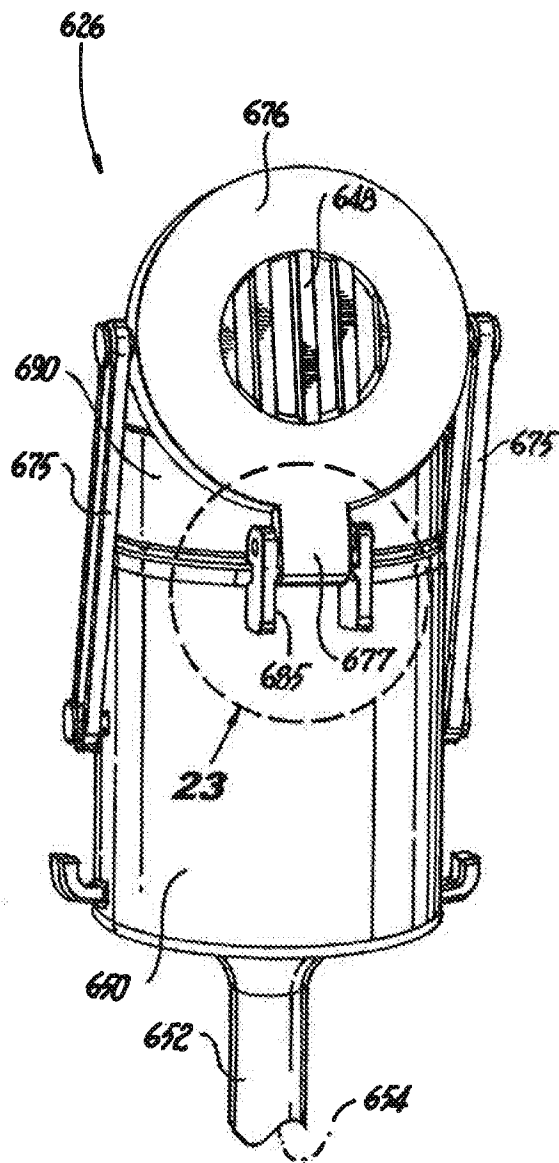


**Fig. 20**

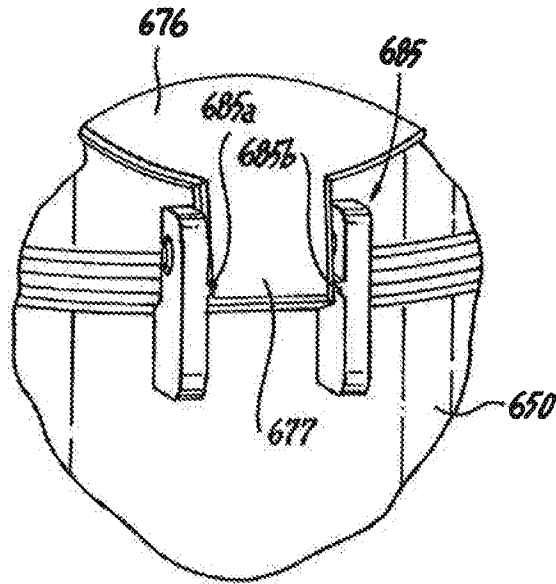
12/26



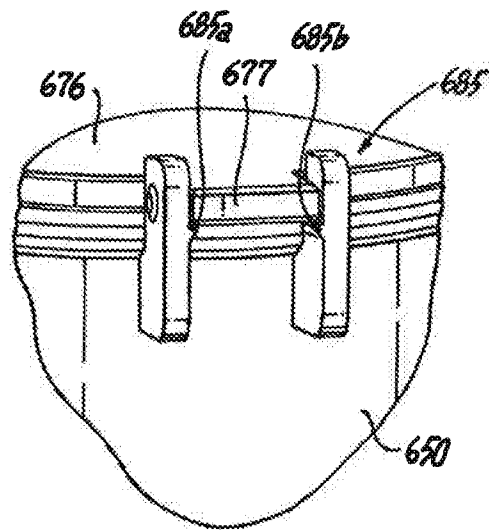
**Fig. 21**



**Fig. 22**



**Fig. 23**



**Fig. 24**

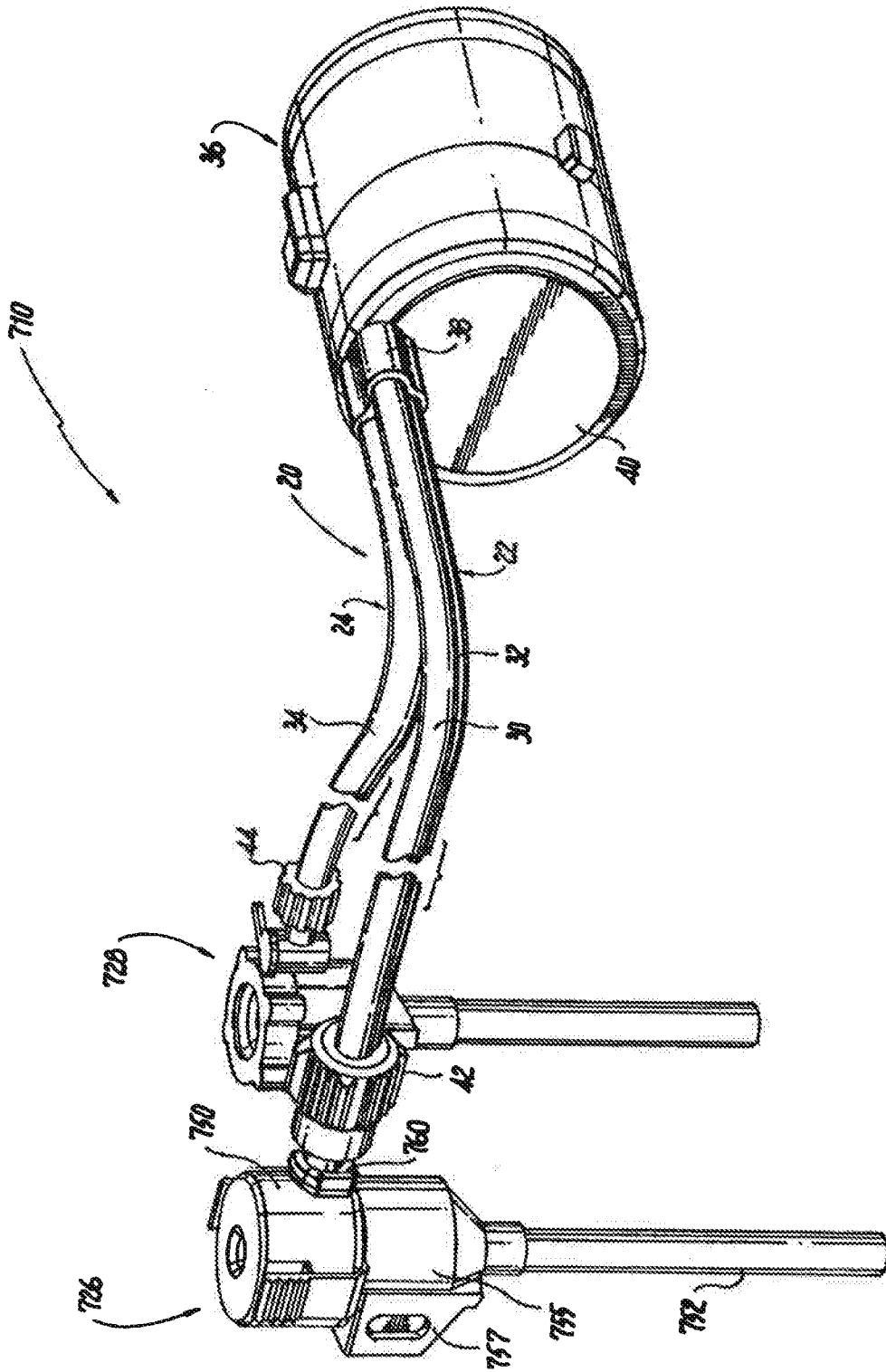
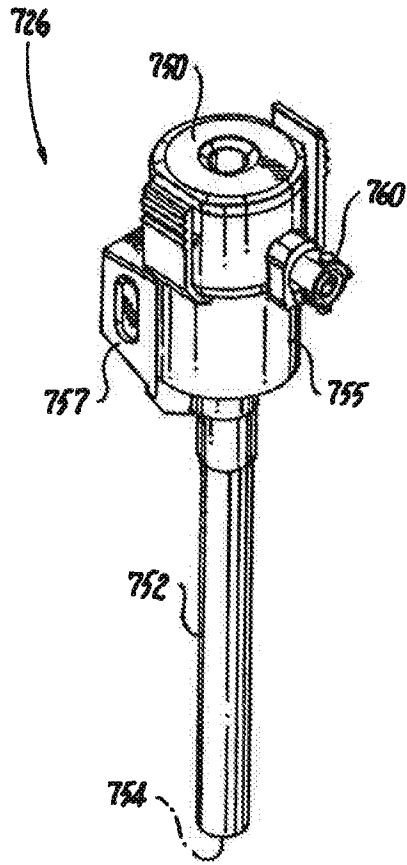
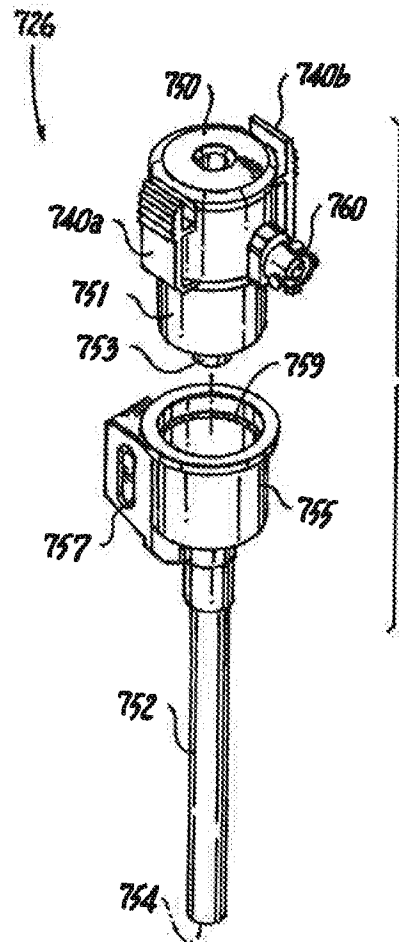


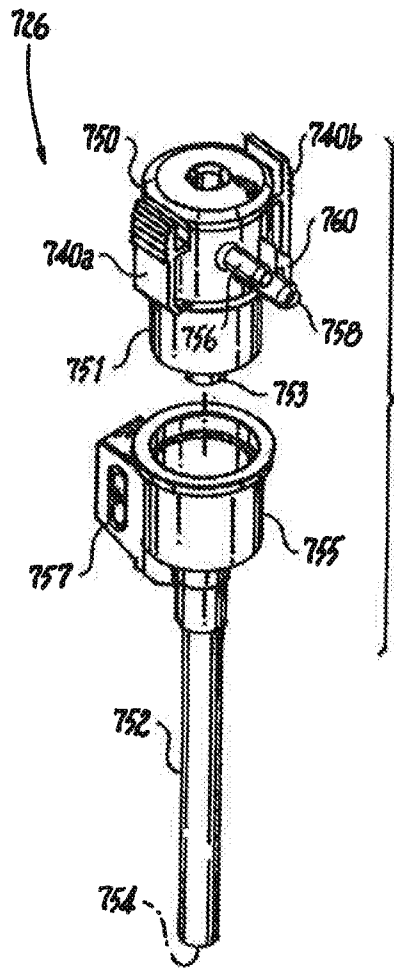
Fig. 25



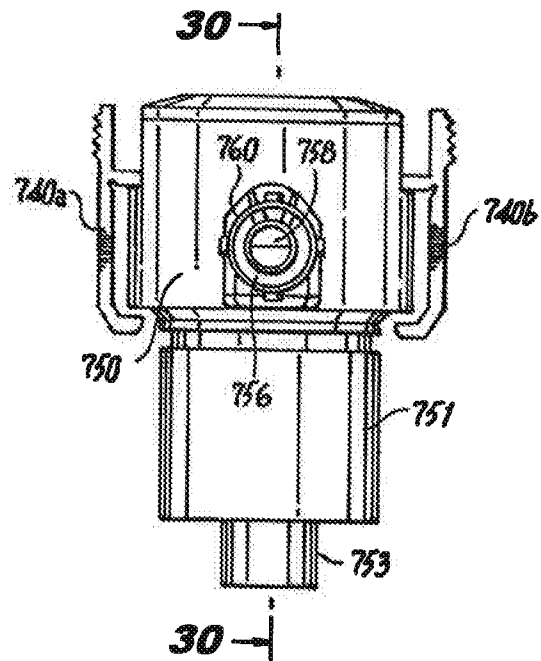
**Fig. 26**



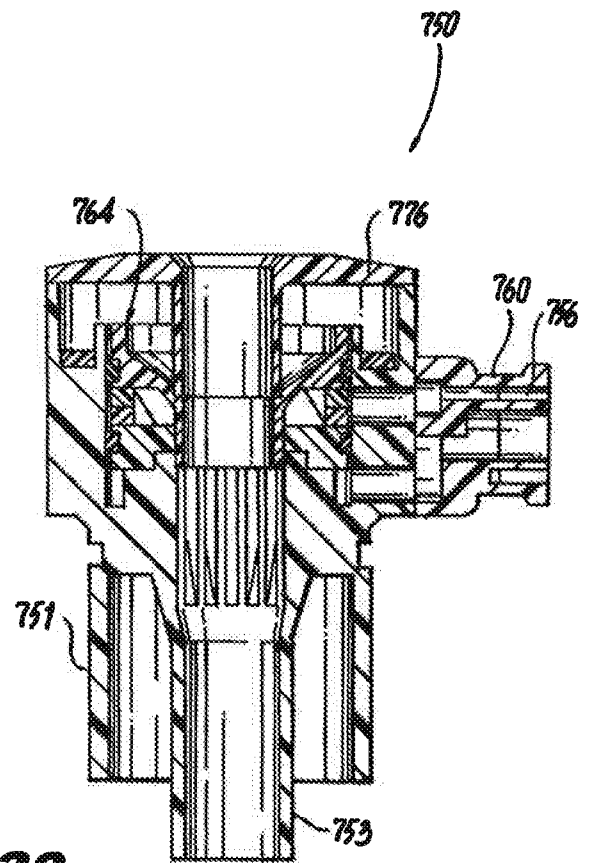
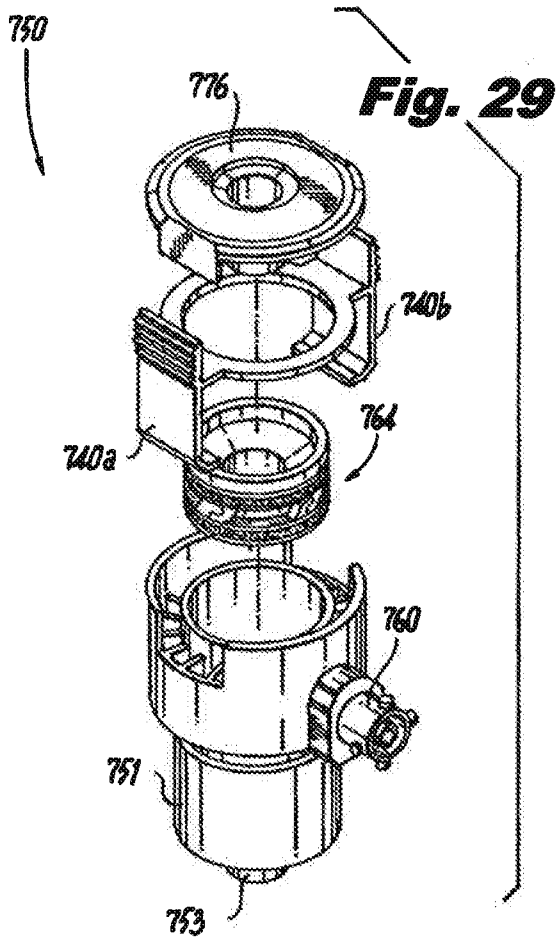
**Fig. 27**

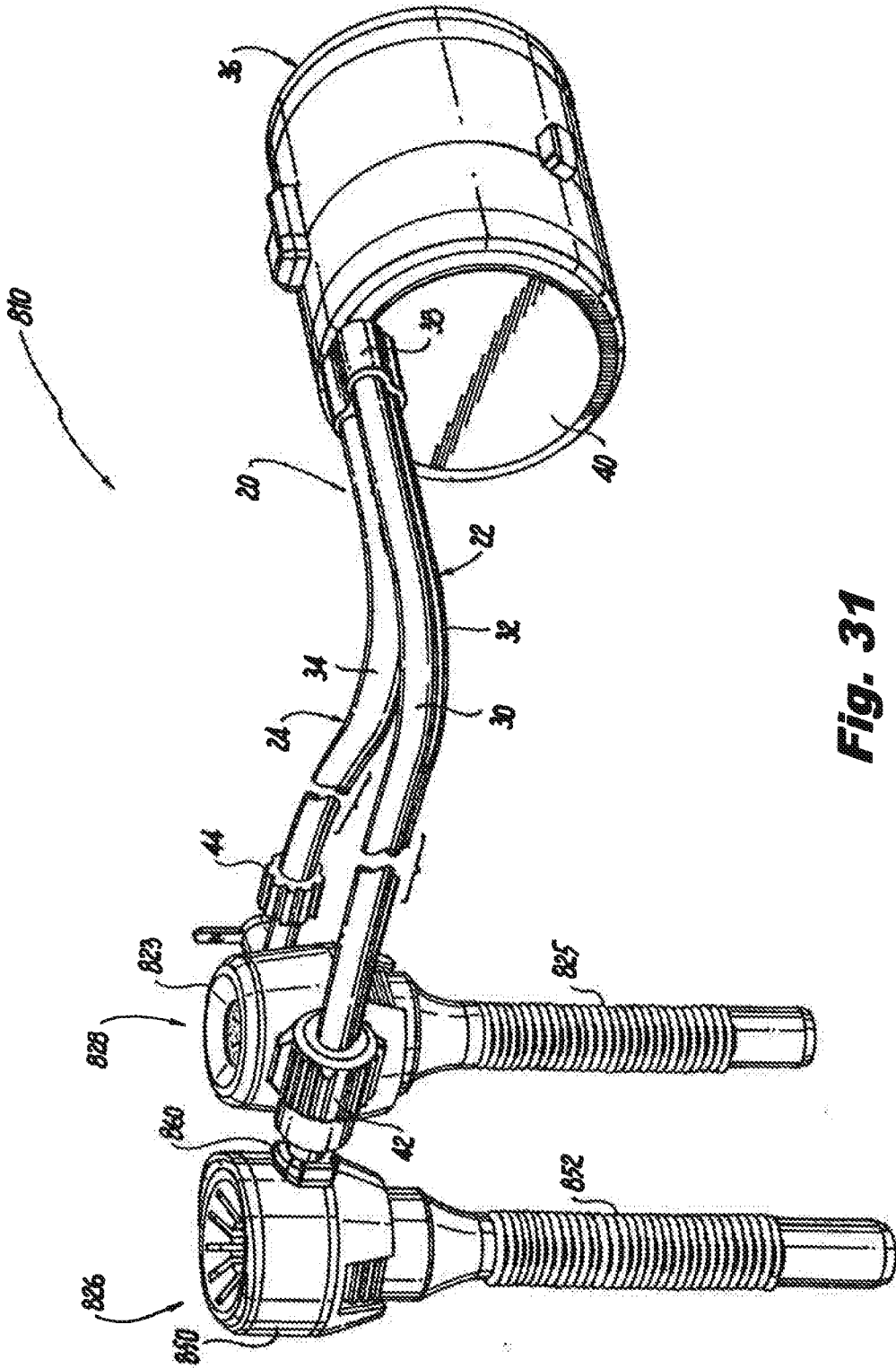


**Fig. 27a**

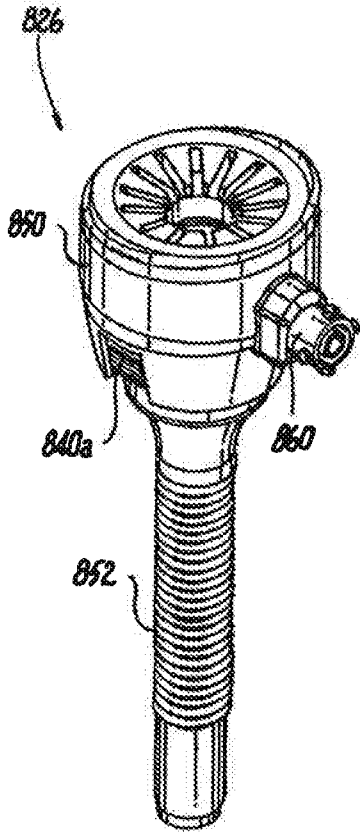


**Fig. 28**

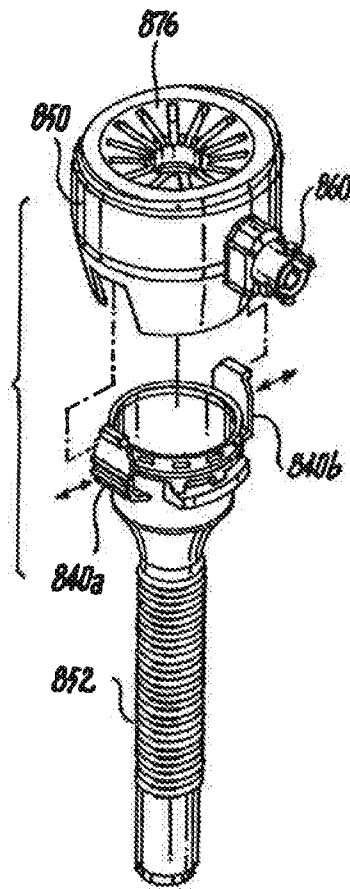




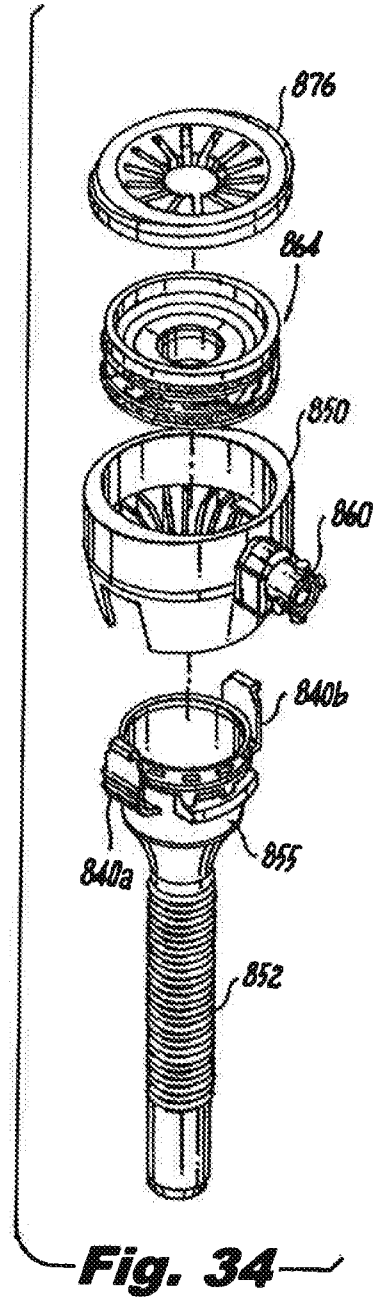
**Fig. 31**



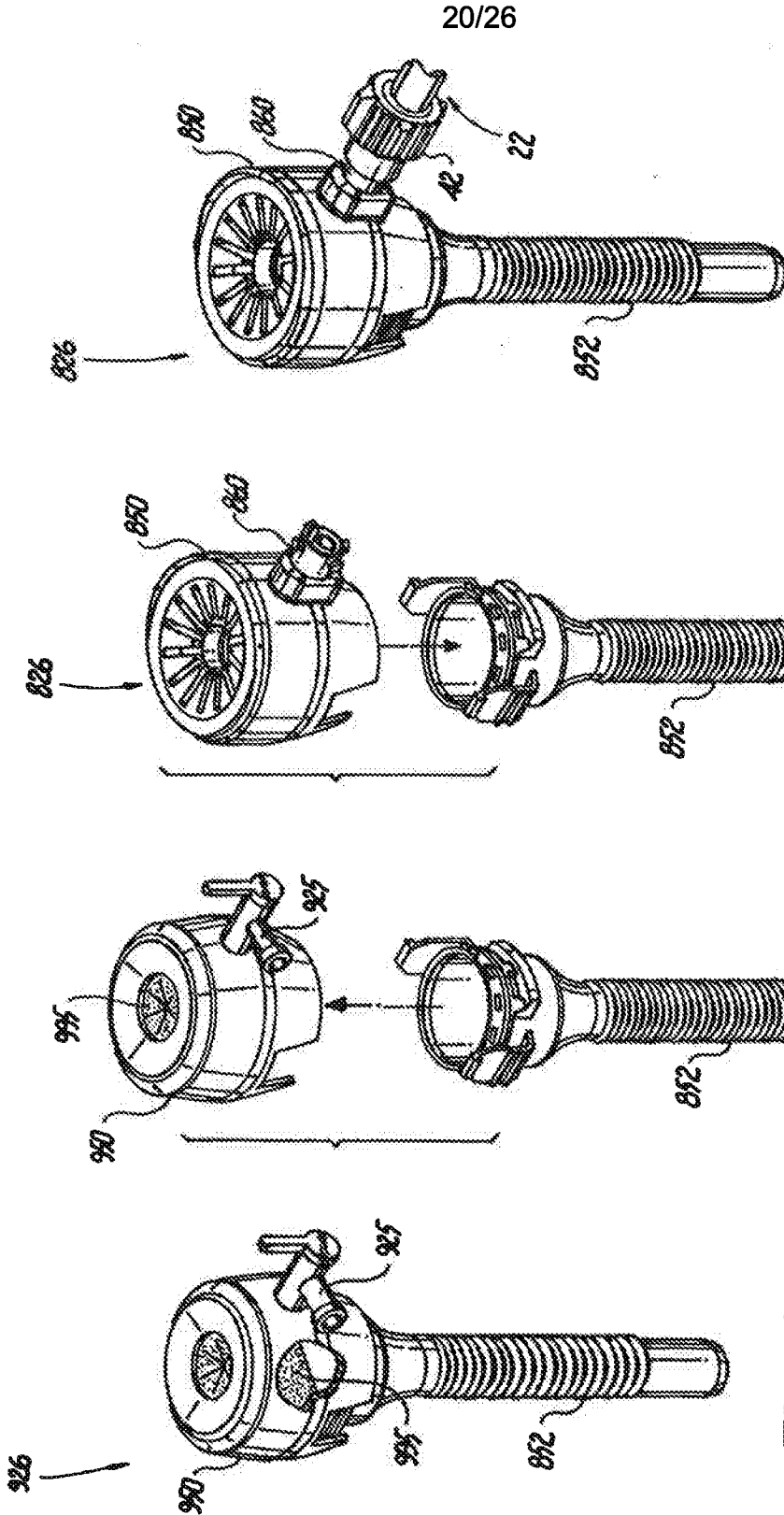
**Fig. 32**

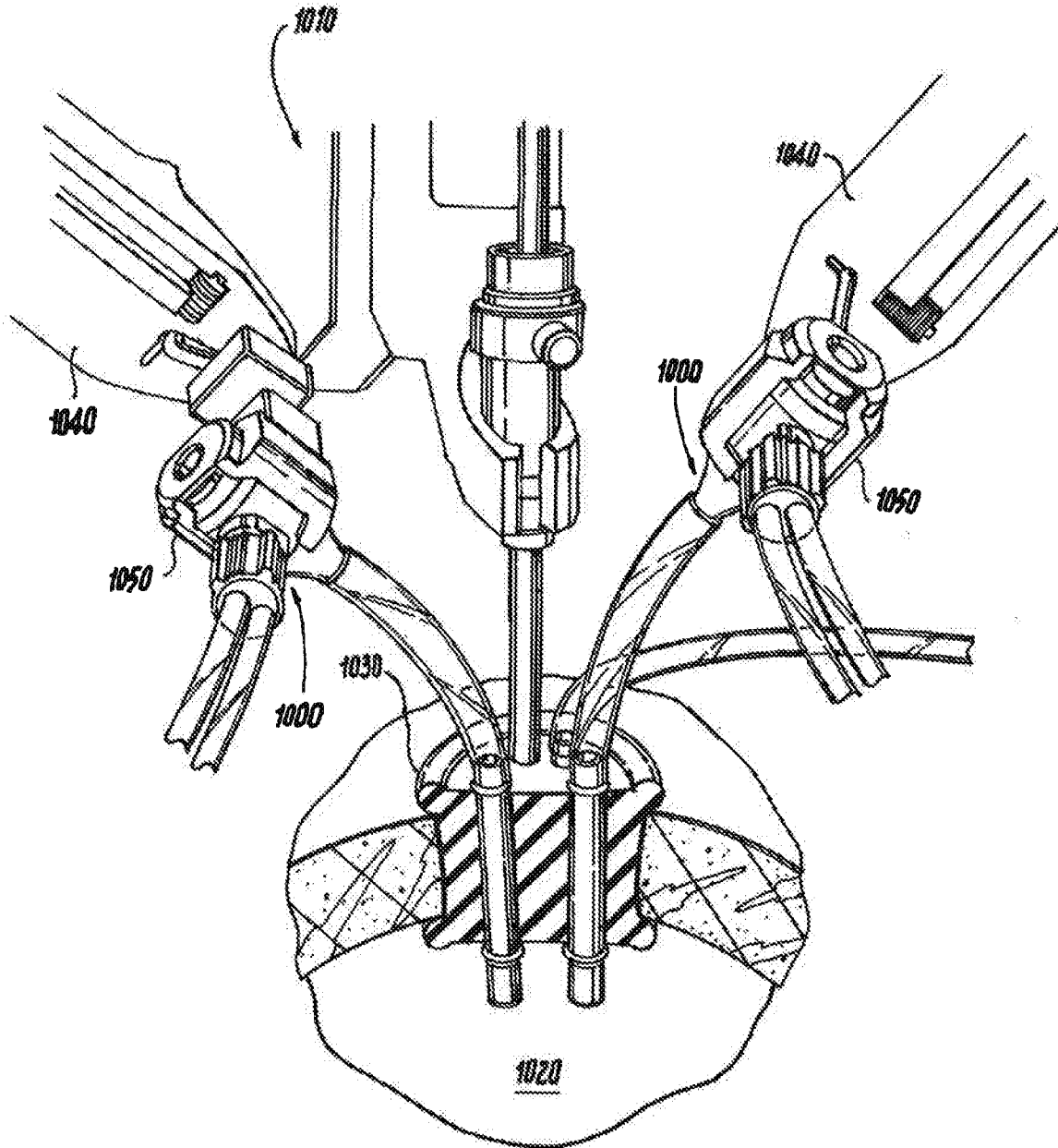


**Fig. 33**

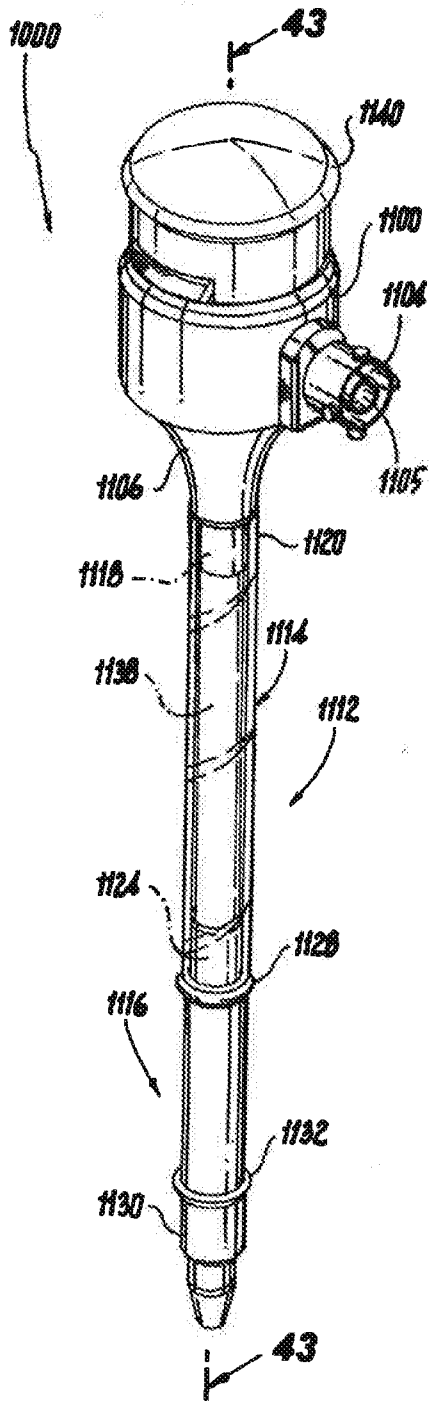


**Fig. 34**

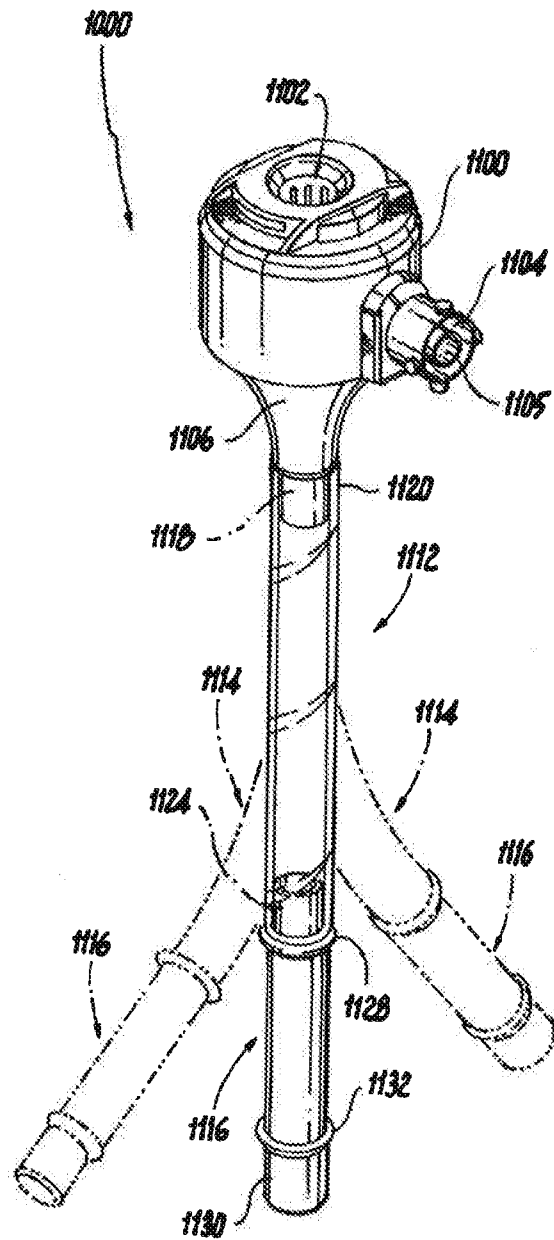




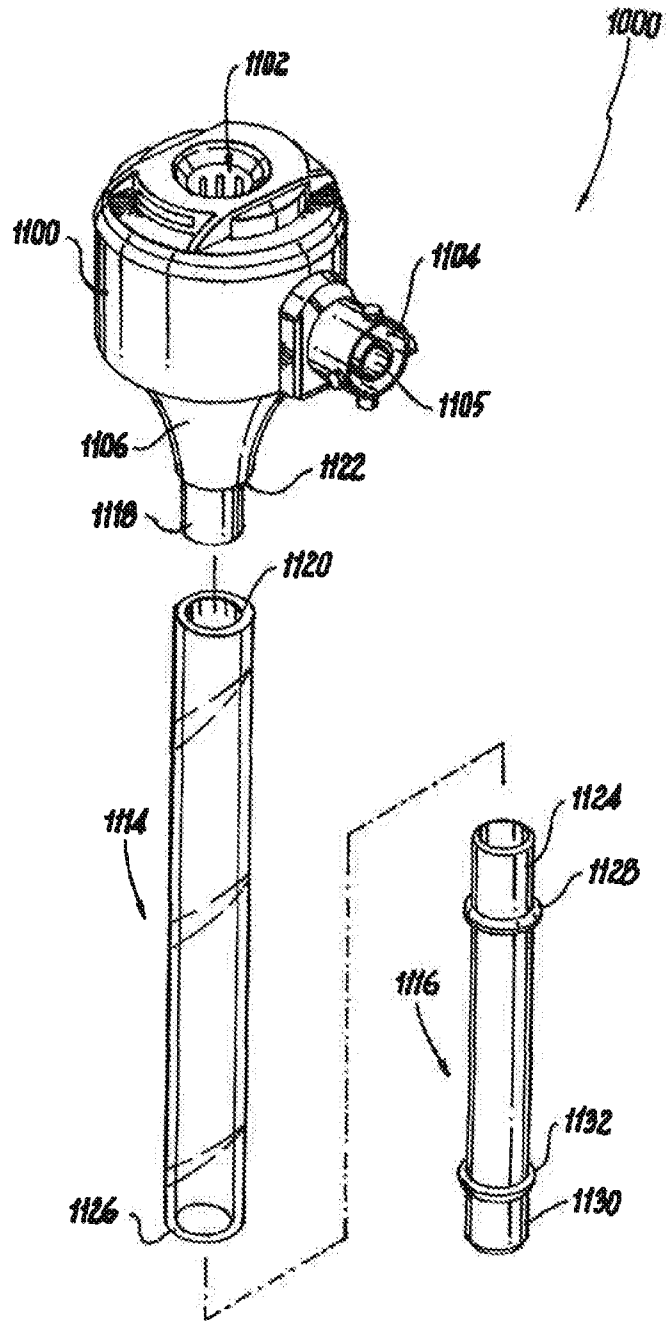
**Fig. 39**



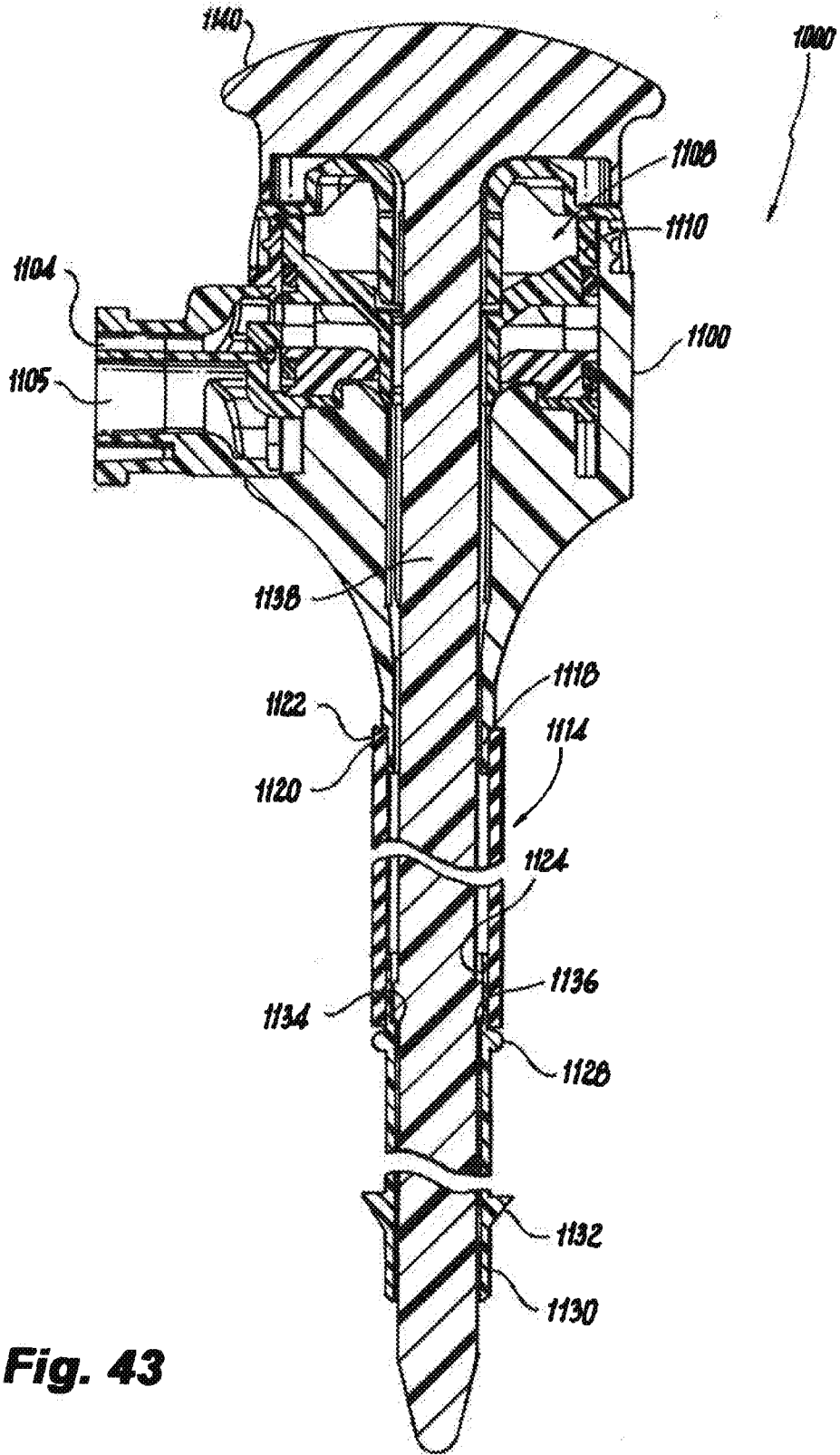
**Fig. 40**



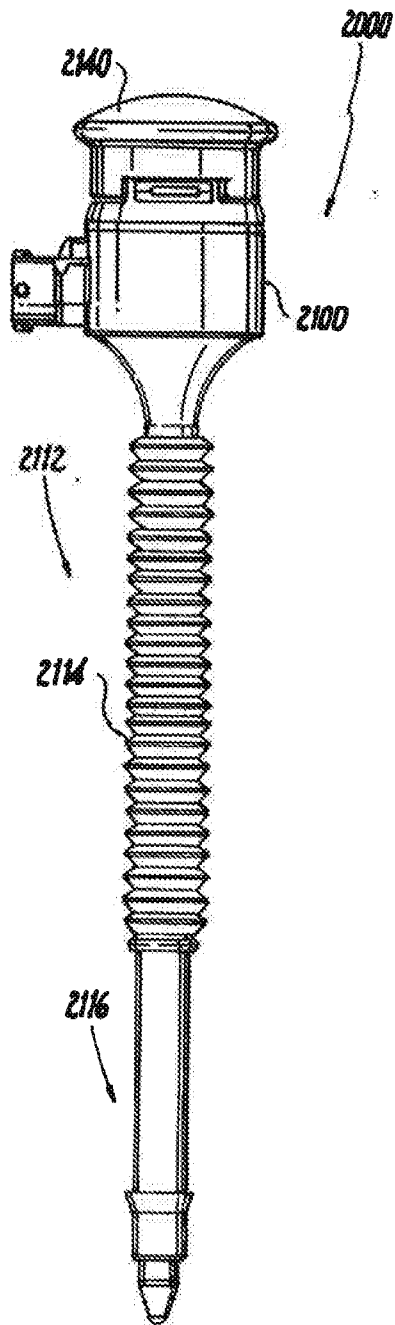
**Fig. 41**



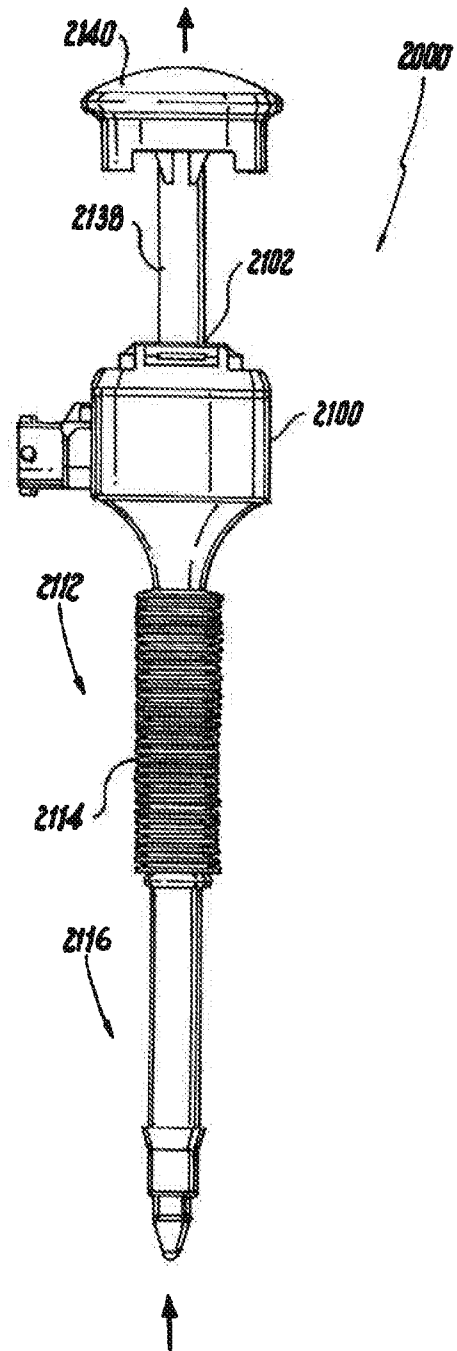
**Fig. 42**



**Fig. 43**



**Fig. 44**



**Fig. 45**



**A. CLASSIFICATION OF SUBJECT MATTER****A61B 17/34(2006.01)i**

According to International Patent Classification (IPC) or to both national classification and IPC

**B. FIELDS SEARCHED**Minimum documentation searched (classification system followed by classification symbols)  
A61B 17/34; A61B 17/00; A61B 17/02; A61M 13/00; A61M 39/10Documentation searched other than minimum documentation to the extent that such documents are included in the fields searched  
Korean utility models and applications for utility models  
Japanese utility models and applications for utility modelsElectronic data base consulted during the international search (name of data base and, where practicable, search terms used)  
eKOMPASS(KIPO internal) & Keywords: access, port, gas, seal, endoscopic**C. DOCUMENTS CONSIDERED TO BE RELEVANT**

Category*	Citation of document, with indication, where appropriate, of the relevant passages	Relevant to claim No.
Y	US 8795223 B2 (STEARNS et al.) 05 August 2014 See column 5, line 13 - column 7, line 8, claim 1 and figures 1,2,21(A),21(B).	1-20
Y	US 2016-0220271 A1 (SURGIQUEST, INC.) 04 August 2016 See paragraphs [36]-[41], claims 1,11 and figures 1-7.	1-20
A	US 2015-0173792 A1 (APPLIED MEDICAL RESOURCES CORPORATION) 25 June 2015 See the whole document.	1-20
A	US 2018-0104423 A1 (ETHICON LLC) 19 April 2018 See the whole document.	1-20
A	US 2014-0171855 A1 (SURGIQUEST, INC.) 19 June 2014 See the whole document.	1-20

 Further documents are listed in the continuation of Box C. See patent family annex.

\* Special categories of cited documents:

"A" document defining the general state of the art which is not considered to be of particular relevance

"D" document cited by the applicant in the international application

"E" earlier application or patent but published on or after the international filing date

"L" document which may throw doubts on priority claim(s) or which is cited to establish the publication date of another citation or other special reason (as specified)

"O" document referring to an oral disclosure, use, exhibition or other means

"P" document published prior to the international filing date but later than the priority date claimed

"T" later document published after the international filing date or priority date and not in conflict with the application but cited to understand the principle or theory underlying the invention

"X" document of particular relevance; the claimed invention cannot be considered novel or cannot be considered to involve an inventive step when the document is taken alone

"Y" document of particular relevance; the claimed invention cannot be considered to involve an inventive step when the document is combined with one or more other such documents, such combination being obvious to a person skilled in the art

"&amp;" document member of the same patent family

Date of the actual completion of the international search

11 October 2019 (11.10.2019)

Date of mailing of the international search report

**11 October 2019 (11.10.2019)**

Name and mailing address of the ISA/KR

International Application Division

Korean Intellectual Property Office

189 Cheongsa-ro, Seo-gu, Daejeon, 35208, Republic of Korea

Facsimile No. +82-42-481-8578

Authorized officer

Kim, Yeonkyung

Telephone No. +82-42-481-3325



**INTERNATIONAL SEARCH REPORT**

Information on patent family members

International application No.

**PCT/US2019/037488**

Patent document cited in search report	Publication date	Patent family member(s)	Publication date
US 8795223 B2	05/08/2014	AT 498364 T	15/03/2011
		CA 2662417 A1	13/03/2008
		CA 2662417 C	10/02/2015
		CA 2664483 A1	10/04/2008
		CA 2664483 C	28/10/2014
		CA 2842217 A1	13/03/2008
		CA 2842217 C	06/09/2016
		CN 102264309 A	30/11/2011
		CN 102264309 B	29/01/2014
		CN 102264310 A	30/11/2011
		CN 102264310 B	22/01/2014
		CN 102264451 A	30/11/2011
		CN 102264451 B	24/12/2014
		EP 2059181 A1	20/05/2009
		EP 2059181 B1	16/02/2011
		EP 2066244 A1	10/06/2009
		EP 2066244 B1	05/06/2013
		EP 2068732 A2	17/06/2009
		EP 2068732 B1	23/04/2014
		EP 2101662 A2	23/09/2009
		EP 2101662 B1	11/07/2018
		EP 2134238 A2	23/12/2009
		EP 2134238 B1	03/08/2016
		EP 2136721 A2	30/12/2009
		EP 2136721 B1	23/07/2014
		EP 2329774 A1	08/06/2011
		EP 2329774 B1	25/07/2012
		EP 2337508 A2	29/06/2011
		EP 2337508 A4	19/12/2012
		EP 2337508 B1	05/12/2018
		EP 2341849 A2	13/07/2011
		EP 2341849 A4	29/04/2015
		EP 2349033 A2	03/08/2011
		EP 2349033 A4	06/07/2016
		EP 2364197 A2	14/09/2011
		EP 2364197 A4	13/06/2012
EP 2364197 B1	15/01/2014		
EP 2482869 A1	08/08/2012		
EP 2485664 A2	15/08/2012		
EP 2485664 B1	27/02/2019		
EP 2537477 A1	26/12/2012		
EP 2537477 B1	03/12/2014		
EP 2618887 A2	31/07/2013		
EP 2618887 A4	08/10/2014		
EP 2618909 A2	31/07/2013		
EP 2618909 A4	18/06/2014		
JP 2010-502360 A	28/01/2010		
JP 2010-523289 A	15/07/2010		
JP 2012-505027 A	01/03/2012		

**INTERNATIONAL SEARCH REPORT**

Information on patent family members

International application No.

**PCT/US2019/037488**

Patent document cited in search report	Publication date	Patent family member(s)	Publication date
		JP 2012-505055 A	01/03/2012
		JP 2012-505056 A	01/03/2012
		JP 2012-505057 A	01/03/2012
		JP 2013-505812 A	21/02/2013
		JP 2013-541972 A	21/11/2013
		JP 2014-239907 A	25/12/2014
		JP 5226065 B2	03/07/2013
		JP 5514544 B2	04/06/2014
		JP 5654996 B2	14/01/2015
		JP 5671542 B2	18/02/2015
		JP 5733831 B2	10/06/2015
		JP 5745413 B2	08/07/2015
		JP 6019025 B2	02/11/2016
		KR 10-1622426 B1	18/05/2016
		KR 10-1649505 B1	19/08/2016
		KR 10-1680588 B1	29/11/2016
		KR 10-1829726 B1	19/02/2018
		KR 10-2011-0079885 A	11/07/2011
		KR 10-2011-0079896 A	11/07/2011
		KR 10-2011-0079897 A	11/07/2011
		KR 10-2011-0084236 A	21/07/2011
		KR 10-2016-0099114 A	19/08/2016
		KR 10-2017-0068606 A	19/06/2017
		US 10092319 B2	09/10/2018
		US 2004-0204671 A1	14/10/2004
		US 2005-0004512 A1	06/01/2005
		US 2005-0015043 A1	20/01/2005
		US 2007-0088274 A1	19/04/2007
		US 2007-0088275 A1	19/04/2007
		US 2007-0088276 A1	19/04/2007
		US 2008-0086080 A1	10/04/2008
		US 2008-0086160 A1	10/04/2008
		US 2008-0086167 A1	10/04/2008
		US 2008-0262302 A1	23/10/2008
		US 2009-0137943 A1	28/05/2009
		US 2010-0170208 A1	08/07/2010
		US 2010-0185057 A1	22/07/2010
		US 2010-0185058 A1	22/07/2010
		US 2010-0185139 A1	22/07/2010
		US 2011-0125084 A1	26/05/2011
		US 2011-0266211 A1	03/11/2011
		US 2012-0138523 A1	07/06/2012
		US 2012-0150101 A1	14/06/2012
		US 2012-0245511 A1	27/09/2012
		US 2013-0012782 A1	10/01/2013
		US 2013-0060091 A1	07/03/2013
		US 2013-0231606 A1	05/09/2013
		US 2014-0188038 A1	03/07/2014
		US 2014-0309583 A1	16/10/2014
		US 2014-0323807 A1	30/10/2014

**INTERNATIONAL SEARCH REPORT**

Information on patent family members

International application No.

**PCT/US2019/037488**

Patent document cited in search report	Publication date	Patent family member(s)	Publication date
		US 2014-0336567 A1	13/11/2014
		US 2014-0358070 A1	04/12/2014
		US 2015-0025323 A1	22/01/2015
		US 2015-0202389 A1	23/07/2015
		US 2015-0202390 A1	23/07/2015
		US 2015-0202391 A1	23/07/2015
		US 2018-0236186 A1	23/08/2018
		US 2018-0296245 A1	18/10/2018
		US 7182752 B2	27/02/2007
		US 7285112 B2	23/10/2007
		US 7338473 B2	04/03/2008
		US 7413559 B2	19/08/2008
		US 7798998 B2	21/09/2010
		US 7806870 B2	05/10/2010
		US 7854724 B2	21/12/2010
		US 7976598 B2	12/07/2011
		US 8088189 B2	03/01/2012
		US 8216189 B2	10/07/2012
		US 8317815 B2	27/11/2012
		US 8715219 B2	06/05/2014
		US 8795235 B2	05/08/2014
		US 8961451 B2	24/02/2015
		US 8974569 B2	10/03/2015
		US 9067030 B2	30/06/2015
		US 9084628 B2	21/07/2015
		US 9095372 B2	04/08/2015
		US 9155557 B2	13/10/2015
		US 9199047 B2	01/12/2015
		US 9289233 B2	22/03/2016
		US 9295490 B2	29/03/2016
		US 9375539 B2	28/06/2016
		US 9526849 B2	27/12/2016
		US 9597112 B2	21/03/2017
		US 9907569 B2	06/03/2018
		US 9950127 B2	24/04/2018
		US D663838 S1	17/07/2012
		US D667954 S1	25/09/2012
		US RE44972 E1	01/07/2014
		WO 2008-030256 A1	13/03/2008
		WO 2008-042005 A1	10/04/2008
		WO 2008-045316 A2	17/04/2008
		WO 2008-045316 A3	02/10/2008
		WO 2008-077080 A2	26/06/2008
		WO 2008-077080 A3	30/04/2009
		WO 2008-128142 A2	23/10/2008
		WO 2008-128142 A3	24/12/2008
		WO 2008-130582 A2	30/10/2008
		WO 2008-130582 A3	24/12/2008
		WO 2010-042204 A2	15/04/2010
		WO 2010-042204 A3	22/07/2010

## INTERNATIONAL SEARCH REPORT

Information on patent family members

International application No.

**PCT/US2019/037488**

Patent document cited in search report	Publication date	Patent family member(s)	Publication date
		WO 2010-042913 A2	15/04/2010
		WO 2010-042913 A3	15/07/2010
		WO 2010-042914 A2	15/04/2010
		WO 2010-042914 A3	29/07/2010
		WO 2010-042915 A2	15/04/2010
		WO 2010-042915 A3	29/07/2010
		WO 2011-041387 A1	07/04/2011
		WO 2011-044448 A2	14/04/2011
		WO 2011-044448 A3	03/06/2011
		WO 2012-040221 A2	29/03/2012
		WO 2012-040221 A3	07/06/2012
		WO 2012-044410 A2	05/04/2012
		WO 2012-044410 A3	28/06/2012
		WO 2012-122263 A2	13/09/2012
		WO 2012-122263 A3	10/01/2013
US 2016-0220271 A1	04/08/2016	AU 2016-211938 A1	24/08/2017
		CA 2974896 A1	04/08/2016
		CN 107438445 A	05/12/2017
		EP 3250136 A1	06/12/2017
		JP 2018-503477 A	08/02/2018
		JP 6434639 B2	05/12/2018
		KR 10-2017-0118097 A	24/10/2017
		US 9801656 B2	31/10/2017
		WO 2016-122937 A1	04/08/2016
US 2015-0173792 A1	25/06/2015	AU 2006-304892 A1	26/04/2007
		AU 2006-304894 A1	26/04/2007
		AU 2006-304894 B2	04/10/2012
		EP 1933718 A2	25/06/2008
		EP 1933718 B1	03/02/2010
		EP 1933733 A2	25/06/2008
		EP 2000099 A2	10/12/2008
		EP 2000099 A3	29/07/2009
		US 2007-0088277 A1	19/04/2007
		US 2007-0088370 A1	19/04/2007
		US 2013-0237902 A1	12/09/2013
		US 2014-0249541 A1	04/09/2014
		US 2018-0116692 A1	03/05/2018
		US 8430851 B2	30/04/2013
		US 8721658 B2	13/05/2014
		US 8968250 B2	03/03/2015
		US 9579115 B2	28/02/2017
		US 9833259 B2	05/12/2017
		WO 2007-048083 A2	26/04/2007
		WO 2007-048083 A3	03/07/2008
		WO 2007-048085 A2	26/04/2007
		WO 2007-048085 A3	02/08/2007
US 2018-0104423 A1	19/04/2018	AT 539690 T	15/01/2012

**INTERNATIONAL SEARCH REPORT**

Information on patent family members

International application No.

**PCT/US2019/037488**

Patent document cited in search report	Publication date	Patent family member(s)	Publication date
		AT 555713 T	15/05/2012
		AU 2006-235409 A1	19/10/2006
		AU 2006-235409 B2	17/11/2011
		AU 2009-201498 A1	12/11/2009
		AU 2009-201659 A1	12/11/2009
		AU 2009-201659 B2	05/12/2013
		AU 2009-201660 A1	12/11/2009
		AU 2009-201660 B2	09/01/2014
		AU 2009-201661 A1	12/11/2009
		AU 2009-201661 B2	16/01/2014
		AU 2009-201662 A1	12/11/2009
		AU 2009-201662 B2	13/02/2014
		AU 2009-217466 A1	15/04/2010
		AU 2009-217467 A1	15/04/2010
		AU 2009-217470 A1	15/04/2010
		AU 2009-217474 A1	15/04/2010
		AU 2009-217474 B2	09/04/2015
		AU 2009-222422 A1	15/04/2010
		AU 2009-222422 B2	11/12/2014
		AU 2009-222423 A1	15/04/2010
		AU 2009-222423 B2	18/12/2014
		AU 2009-222425 A1	15/04/2010
		AU 2009-222425 B2	27/11/2014
		AU 2010-200626 A1	23/09/2010
		AU 2010-200626 B2	05/03/2015
		AU 2010-200628 A1	23/09/2010
		AU 2010-200629 A1	23/09/2010
		AU 2010-200630 A1	23/09/2010
		AU 2010-200631 A1	23/09/2010
		AU 2010-200632 A1	23/09/2010
		AU 2010-200982 A1	14/10/2010
		AU 2010-200982 A8	28/01/2016
		AU 2010-200982 B2	21/01/2016
		AU 2010-201024 A1	14/10/2010
		AU 2010-201024 B2	14/05/2015
		AU 2010-276622 A1	16/02/2012
		AU 2010-276622 B2	27/02/2014
		AU 2011-316659 A1	02/05/2013
		AU 2011-316659 B2	23/07/2015
		BR 112013009059 A2	19/07/2016
		BR PI0903936 A2	20/07/2010
		BR PI0903942 A2	20/07/2010
		BR PI0904876 A2	08/02/2011
		BR PI0904882 A2	15/03/2011
		BR PI0904968 A2	15/03/2011
		BR PI0904969 A2	15/03/2011
		BR PI0905399 A2	22/03/2011
		CA 2603845 A1	19/10/2006
		CA 2603845 C	04/02/2014
		CA 2663471 A1	25/10/2009

**INTERNATIONAL SEARCH REPORT**

Information on patent family members

International application No.

**PCT/US2019/037488**

Patent document cited in search report	Publication date	Patent family member(s)	Publication date
		CA 2664823 A1	28/10/2009
		CA 2664823 C	15/05/2018
		CA 2664831 A1	28/10/2009
		CA 2664831 C	21/06/2016
		CA 2664838 A1	28/10/2009
		CA 2664838 C	20/06/2017
		CA 2664867 A1	28/10/2009
		CA 2664867 C	12/07/2016
		CA 2671694 A1	14/01/2010
		CA 2671694 C	02/01/2018
		CA 2680915 A1	30/03/2010
		CA 2680915 C	07/02/2017
		CA 2680916 A1	30/03/2010
		CA 2680916 C	27/06/2017
		CA 2680917 A1	30/03/2010
		CA 2680917 C	17/10/2017
		CA 2680944 A1	30/03/2010
		CA 2680944 C	05/12/2017
		CA 2695332 A1	06/09/2010
		CA 2695555 A1	06/09/2010
		CA 2695558 A1	06/09/2010
		CA 2695714 A1	06/09/2010
		CA 2695725 A1	06/09/2010
		CA 2695725 C	29/08/2017
		CA 2695831 A1	06/09/2010
		CA 2698004 A1	30/09/2010
		CA 2698004 C	30/01/2018
		CA 2698059 A1	30/09/2010
		CA 2698059 C	12/09/2017
		CA 2769469 A1	03/02/2011
		CA 2769469 C	28/11/2017
		CA 2814501 A1	19/04/2012
		CA 2814501 C	11/09/2018
		CA 2960251 A1	30/03/2010
		CA 2960251 C	26/02/2019
		CA 2960252 A1	30/03/2010
		CA 2965961 A1	28/10/2009
		CN 101564284 A	28/10/2009
		CN 101569518 A	04/11/2009
		CN 101569518 B	27/08/2014
		CN 101569519 A	04/11/2009
		CN 101569519 B	21/05/2014
		CN 101569557 A	04/11/2009
		CN 101569558 A	04/11/2009
		CN 101569558 B	08/01/2014
		CN 101627894 A	20/01/2010
		CN 101627894 B	07/08/2013
		CN 101711687 A	26/05/2010
		CN 101711687 B	07/08/2013
		CN 101711688 A	26/05/2010

**INTERNATIONAL SEARCH REPORT**

Information on patent family members

International application No.

**PCT/US2019/037488**

Patent document cited in search report	Publication date	Patent family member(s)	Publication date
		CN 101711688 B	27/02/2013
		CN 101711689 A	26/05/2010
		CN 101711691 A	26/05/2010
		CN 101711692 A	26/05/2010
		CN 101711693 A	26/05/2010
		CN 101711693 B	19/06/2013
		CN 101711694 A	26/05/2010
		CN 101711694 B	16/07/2014
		CN 101822551 A	08/09/2010
		CN 101822552 A	08/09/2010
		CN 101822553 A	08/09/2010
		CN 101822554 A	08/09/2010
		CN 101822555 A	08/09/2010
		CN 101822556 A	08/09/2010
		CN 101822556 B	22/04/2015
		CN 101827627 A	08/09/2010
		CN 101827627 B	05/12/2012
		CN 101849847 A	06/10/2010
		CN 101849847 B	14/05/2014
		CN 101849848 A	06/10/2010
		CN 101849848 B	26/03/2014
		CN 102573676 A	11/07/2012
		CN 102573676 B	27/04/2016
		CN 103249367 A	14/08/2013
		CN 103249367 B	10/08/2016
		EP 1871456 A2	02/01/2008
		EP 1871456 A4	25/04/2012
		EP 1871456 B1	24/12/2014
		EP 2111808 A2	28/10/2009
		EP 2111808 A3	23/06/2010
		EP 2113212 A1	04/11/2009
		EP 2113212 B1	06/08/2014
		EP 2113213 A1	04/11/2009
		EP 2113213 B1	08/04/2015
		EP 2113214 A1	04/11/2009
		EP 2113214 B1	13/08/2014
		EP 2113215 A1	04/11/2009
		EP 2113215 B1	27/08/2014
		EP 2145578 A1	20/01/2010
		EP 2145578 B1	02/05/2012
		EP 2168502 A2	31/03/2010
		EP 2168502 A3	07/04/2010
		EP 2168508 A2	31/03/2010
		EP 2168508 A3	26/05/2010
		EP 2168508 B1	25/10/2017
		EP 2168510 A1	31/03/2010
		EP 2168510 B1	12/12/2012
		EP 2168511 A2	31/03/2010
		EP 2168511 A3	14/07/2010
		EP 2168511 B1	11/07/2012

**INTERNATIONAL SEARCH REPORT**

Information on patent family members

International application No.

**PCT/US2019/037488**

Patent document cited in search report	Publication date	Patent family member(s)	Publication date
		EP 2168512 A1	31/03/2010
		EP 2168512 B1	12/11/2014
		EP 2172156 A1	07/04/2010
		EP 2177166 A1	21/04/2010
		EP 2226023 A1	08/09/2010
		EP 2226023 B1	04/01/2012
		EP 2226024 A2	08/09/2010
		EP 2226024 A3	01/12/2010
		EP 2226025 A1	08/09/2010
		EP 2226026 A1	08/09/2010
		EP 2226026 B1	29/04/2015
		EP 2226027 A1	08/09/2010
		EP 2238926 A2	13/10/2010
		EP 2238926 A3	22/04/2015
		EP 2238927 A2	13/10/2010
		EP 2238927 A3	26/08/2015
		EP 2459084 A1	06/06/2012
		EP 2459084 B1	22/08/2018
		EP 2502590 A1	26/09/2012
		EP 2502590 B1	01/02/2017
		EP 2502590 B8	19/04/2017
		EP 2502591 A1	26/09/2012
		EP 2502592 A1	26/09/2012
		EP 2502592 B1	03/01/2018
		EP 2502593 A1	26/09/2012
		EP 2502593 B1	13/08/2014
		EP 2627269 A1	21/08/2013
		EP 2627269 B1	28/02/2018
		EP 3292828 A2	14/03/2018
		EP 3292828 A3	27/06/2018
		EP 3459475 A1	27/03/2019
		ES 2621249 T3	03/07/2017
		HK 1136181 A1	19/02/2016
		IN 882DEN2012 A	10/07/2015
		JP 2008-538303 A	23/10/2008
		JP 2009-261948 A	12/11/2009
		JP 2009-261952 A	12/11/2009
		JP 2009-261953 A	12/11/2009
		JP 2009-268902 A	19/11/2009
		JP 2009-268903 A	19/11/2009
		JP 2010-017559 A	28/01/2010
		JP 2010-082444 A	15/04/2010
		JP 2010-082445 A	15/04/2010
		JP 2010-082447 A	15/04/2010
		JP 2010-082449 A	15/04/2010
		JP 2010-082450 A	15/04/2010
		JP 2010-082451 A	15/04/2010
		JP 2010-088879 A	22/04/2010
		JP 2010-207576 A	24/09/2010
		JP 2010-207577 A	24/09/2010

**INTERNATIONAL SEARCH REPORT**

Information on patent family members

International application No.

**PCT/US2019/037488**

Patent document cited in search report	Publication date	Patent family member(s)	Publication date
		JP 2010-207578 A	24/09/2010
		JP 2010-207579 A	24/09/2010
		JP 2010-207580 A	24/09/2010
		JP 2010-240404 A	28/10/2010
		JP 2010-240405 A	28/10/2010
		JP 2013-500766 A	10/01/2013
		JP 2013-544555 A	19/12/2013
		JP 5020936 B2	05/09/2012
		JP 5399149 B2	29/01/2014
		JP 5468293 B2	09/04/2014
		JP 5468342 B2	09/04/2014
		JP 5478933 B2	23/04/2014
		JP 5484780 B2	07/05/2014
		JP 5566652 B2	06/08/2014
		JP 5602461 B2	08/10/2014
		JP 5638270 B2	10/12/2014
		JP 5653590 B2	14/01/2015
		JP 5661767 B2	28/01/2015
		JP 5697321 B2	08/04/2015
		JP 5717974 B2	13/05/2015
		JP 5913778 B2	27/04/2016
		JP 5931074 B2	08/06/2016
		KR 10-1631870 B1	20/06/2016
		KR 10-1655746 B1	08/09/2016
		KR 10-1658858 B1	22/09/2016
		KR 10-1673125 B1	16/11/2016
		KR 10-1673127 B1	07/11/2016
		KR 10-1674379 B1	09/11/2016
		KR 10-1714393 B1	09/03/2017
		KR 10-1734065 B1	11/05/2017
		KR 10-1787959 B1	19/10/2017
		KR 10-2009-0113790 A	02/11/2009
		KR 10-2009-0113791 A	02/11/2009
		KR 10-2009-0113792 A	02/11/2009
		KR 10-2009-0113793 A	02/11/2009
		KR 10-2010-0036987 A	08/04/2010
		KR 10-2010-0036988 A	08/04/2010
		KR 10-2010-0036989 A	08/04/2010
		KR 10-2010-0036991 A	08/04/2010
		KR 10-2010-0100697 A	15/09/2010
		KR 10-2010-0100699 A	15/09/2010
		KR 10-2010-0100700 A	15/09/2010
		KR 10-2010-0100701 A	15/09/2010
		KR 10-2010-0100706 A	15/09/2010
		KR 10-2010-0100707 A	15/09/2010
		KR 10-2010-0109480 A	08/10/2010
		KR 10-2010-0109481 A	08/10/2010
		KR 10-2012-0060830 A	12/06/2012
		KR 10-2017-0001946 A	05/01/2017
		MX 2009004440 A	26/10/2009

**INTERNATIONAL SEARCH REPORT**

Information on patent family members

International application No.

**PCT/US2019/037488**

Patent document cited in search report	Publication date	Patent family member(s)	Publication date
		MX 2009004582 A	27/10/2009
		MX 2009004583 A	27/10/2009
		MX 2009004584 A	27/10/2009
		MX 2009004585 A	27/10/2009
		MX 2009010636 A	29/04/2010
		MX 2009010638 A	29/04/2010
		MX 2009010640 A	29/04/2010
		MX 2009010645 A	14/07/2010
		MX 2012001422 A	12/06/2012
		PL 2459084 T3	31/01/2019
		PL 2502590 T3	31/07/2017
		PL 2502592 T3	29/06/2018
		PL 2627269 T3	31/07/2018
		RU 2009116363 A	10/11/2010
		RU 2009116369 A	10/11/2010
		RU 2009116370 A	10/11/2010
		RU 2009116371 A	10/11/2010
		RU 2012107541 A	10/09/2013
		RU 2013119987 A	20/11/2014
		RU 2508059 C2	27/02/2014
		RU 2516026 C2	20/05/2014
		RU 2522393 C2	10/07/2014
		RU 2522394 C2	10/07/2014
		RU 2577447 C2	20/03/2016
		RU 2582869 C2	27/04/2016
		US 10016215 B2	10/07/2018
		US 10039542 B2	07/08/2018
		US 10182805 B2	22/01/2019
		US 2006-0247500 A1	02/11/2006
		US 2006-0247516 A1	02/11/2006
		US 2006-0247586 A1	02/11/2006
		US 2006-0247673 A1	02/11/2006
		US 2006-0247678 A1	02/11/2006
		US 2006-0258899 A1	16/11/2006
		US 2006-0270911 A1	30/11/2006
		US 2009-0082632 A1	26/03/2009
		US 2009-0118587 A1	07/05/2009
		US 2009-0270681 A1	29/10/2009
		US 2009-0270685 A1	29/10/2009
		US 2009-0270813 A1	29/10/2009
		US 2009-0270817 A1	29/10/2009
		US 2009-0270818 A1	29/10/2009
		US 2010-0010310 A1	14/01/2010
		US 2010-0022958 A1	28/01/2010
		US 2010-0030032 A1	04/02/2010
		US 2010-0081863 A1	01/04/2010
		US 2010-0081864 A1	01/04/2010
		US 2010-0081871 A1	01/04/2010
		US 2010-0081880 A1	01/04/2010
		US 2010-0081881 A1	01/04/2010

**INTERNATIONAL SEARCH REPORT**

Information on patent family members

International application No.

**PCT/US2019/037488**

Patent document cited in search report	Publication date	Patent family member(s)	Publication date
		US 2010-0081882 A1	01/04/2010
		US 2010-0081883 A1	01/04/2010
		US 2010-0228090 A1	09/09/2010
		US 2010-0228091 A1	09/09/2010
		US 2010-0228092 A1	09/09/2010
		US 2010-0228093 A1	09/09/2010
		US 2010-0228094 A1	09/09/2010
		US 2010-0228096 A1	09/09/2010
		US 2010-0228198 A1	09/09/2010
		US 2010-0249516 A1	30/09/2010
		US 2010-0249520 A1	30/09/2010
		US 2010-0249521 A1	30/09/2010
		US 2010-0249525 A1	30/09/2010
		US 2010-0249526 A1	30/09/2010
		US 2010-0261975 A1	14/10/2010
		US 2011-0046449 A1	24/02/2011
		US 2011-0066001 A1	17/03/2011
		US 2011-0306842 A9	15/12/2011
		US 2012-0330099 A1	27/12/2012
		US 2013-0317310 A1	28/11/2013
		US 2014-0121465 A1	01/05/2014
		US 2015-0099938 A1	09/04/2015
		US 2015-0173735 A1	25/06/2015
		US 2015-0209025 A1	30/07/2015
		US 2015-0335353 A1	26/11/2015
		US 2016-0242758 A1	25/08/2016
		US 2016-0317184 A1	03/11/2016
		US 2017-0079637 A1	23/03/2017
		US 2017-0119433 A1	04/05/2017
		US 2017-0215919 A1	03/08/2017
		US 2018-0280055 A1	04/10/2018
		US 2018-0317901 A1	08/11/2018
		US 2018-0344352 A1	06/12/2018
		US 7837612 B2	23/11/2010
		US 8118735 B2	21/02/2012
		US 8206294 B2	26/06/2012
		US 8226553 B2	24/07/2012
		US 8251900 B2	28/08/2012
		US 8273060 B2	25/09/2012
		US 8353824 B2	15/01/2013
		US 8357085 B2	22/01/2013
		US 8425410 B2	23/04/2013
		US 8430811 B2	30/04/2013
		US 8485970 B2	16/07/2013
		US 8517995 B2	27/08/2013
		US 8545450 B2	01/10/2013
		US 8568362 B2	29/10/2013
		US 8579807 B2	12/11/2013
		US 8636686 B2	28/01/2014
		US 8641608 B2	04/02/2014

**INTERNATIONAL SEARCH REPORT**

Information on patent family members

International application No.

**PCT/US2019/037488**

Patent document cited in search report	Publication date	Patent family member(s)	Publication date
		US 8690831 B2	08/04/2014
		US 8821391 B2	02/09/2014
		US 8870747 B2	28/10/2014
		US 8915842 B2	23/12/2014
		US 8926506 B2	06/01/2015
		US 8961406 B2	24/02/2015
		US 9005116 B2	14/04/2015
		US 9033929 B2	19/05/2015
		US 9131835 B2	15/09/2015
		US 9351717 B2	31/05/2016
		US 9358041 B2	07/06/2016
		US 9538997 B2	10/01/2017
		US 9687272 B2	27/06/2017
		US 9737334 B2	22/08/2017
		US 9827383 B2	28/11/2017
		US D700326 S1	25/02/2014
		US D735852 S1	04/08/2015
		US D736926 S1	18/08/2015
		WO 2006-110733 A2	19/10/2006
		WO 2006-110733 A3	08/07/2010
		WO 2011-014394 A1	03/02/2011
		WO 2012-051253 A1	19/04/2012
US 2014-0171855 A1	19/06/2014	CN 104869925 A	26/08/2015
		CN 104869925 B	07/07/2017
		EP 2934352 A1	28/10/2015
		EP 2934352 A4	10/08/2016
		EP 2934352 B1	15/03/2017
		HK 1212187 A1	10/06/2016
		JP 2016-501112 A	18/01/2016
		JP 6483619 B2	13/03/2019
		US 9526886 B2	27/12/2016
		WO 2014-100210 A1	26/06/2014