

A. W. BAILEY.
 TIME CONTROLLED MECHANISM.
 APPLICATION FILED MAY 20, 1909.

967,304.

Patented Aug. 16, 1910.

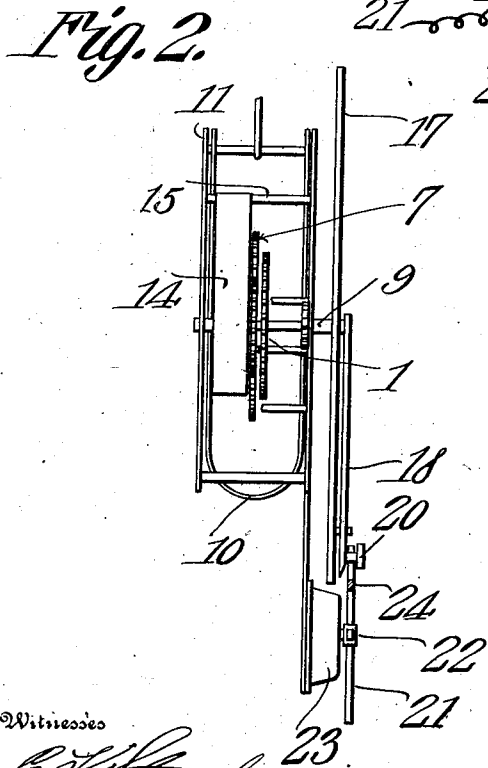
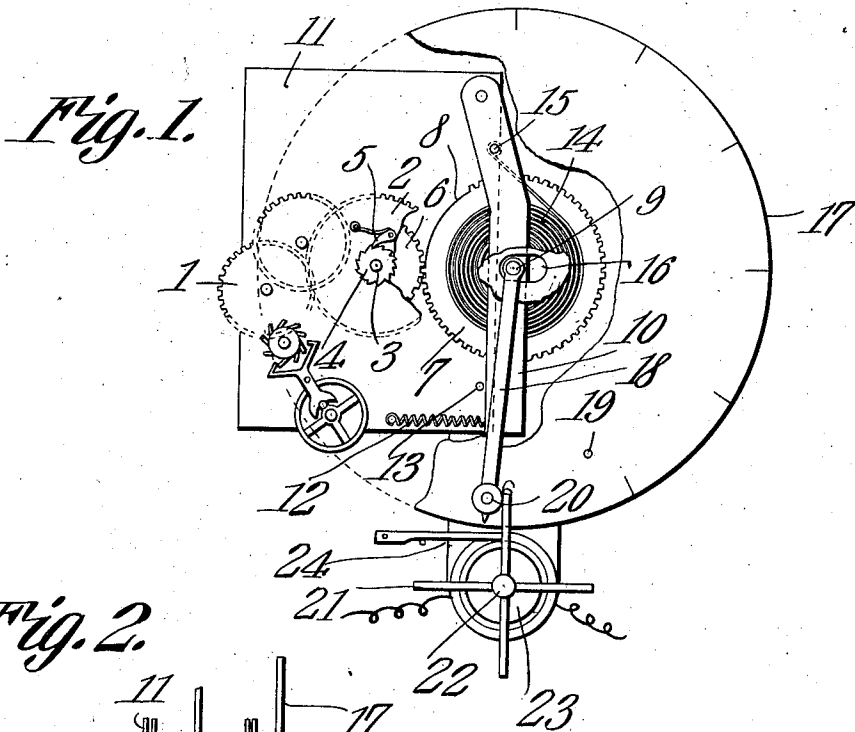

Witnesses

E. J. Stewart
F. T. Chapman

Inventor
Albert W. Bailey.

By *C. Snow & Co.*
 Attorneys

UNITED STATES PATENT OFFICE.

ALBERT WHITON BAILEY, OF SPOKANE, WASHINGTON.

TIME-CONTROLLED MECHANISM.

967,304.

Specification of Letters Patent. Patented Aug. 16, 1910.

Application filed May 20, 1909. Serial No. 497,247.

To all whom it may concern:

Be it known that I, ALBERT WHITON BAILEY, a citizen of the United States, residing at Spokane, in the county of Spokane and State of Washington, have invented a new and useful Time-Controlled Mechanism, of which the following is a specification.

This invention has reference to improvements in time controlled mechanism and is designed to cause the release of stored-up power after a predetermined time interval so that such stored-up power shall in turn cause the operation of another mechanism to accomplish any desired result.

In accordance with the present invention power is stored for the actuation of the time controlling mechanism and such power is sufficiently in excess of the power needed for the time mechanism so that at the expiration of the predetermined time there shall still be sufficient power to cause the actuation of the mechanism designed to be operated after the time interval has elapsed.

The invention is designed more particularly for the actuation of an electric switch to complete or rupture an electric circuit as the case may be or to cause the starting or stopping of any desired mechanism of any character whatsoever wherein the present invention may be applicable.

The invention will be best understood from a consideration of the following detail description taken in connection with the accompanying drawings forming a part of this specification, in which drawings,

Figure 1 is a partially diagrammatic elevation of an apparatus constructed in accordance with the present invention, with parts broken away to disclose more remote parts. Fig. 2 is a side elevation of the structure shown in Fig. 1 with parts in section.

Referring to the drawings there is shown a clock train 1 which may be taken as illustrative of any suitable clock train and which may be modified in any desired manner without affecting the present invention.

The final member 2 of the clock train is mounted loosely on an arbor 3 and the latter has fast thereto at one end a ratchet 4 adjacent to the wheel 3 and the latter carries a spring-actuated pawl 5 so that when the arbor 3 is turned in one direction the ratchet 4 will engage the pawl 5 and cause a rotative movement of the wheel 2, and when the arbor 3 is rotated in the opposite direction the ratchet 4 will ride idly under

the pawl 5 and the wheel 2 will remain quiescent.

The arbor 3 has fast thereto a pinion 6 which in turn is normally in mesh with a gear wheel 7 having a space 8 on its periphery free from gear teeth so that the gear wheel 7 is in effect a mutilated gear. The gear wheel 7 is mounted on an arbor 9 carried by a yoke 10 which latter is pivoted at the free end of its legs to a suitable casing 11 carrying the clock train 1. The yoke 10 is under the normal control of a spring 12 tending at all times to maintain the gear wheel 7 in mesh with the pinion 6, and a stop pin 13 limits the movement of the yoke 10 under the action of the spring 12.

Fast to the arbor 9 is one end of a spiral spring 14 while the other end of this spring is made fast to a pin 15 on the yoke 10. The arbor 9 extends through a slot 16 in a dial 17 and exterior to the dial the arbor carries an arm 18 parallel with said dial and extending to approximately the periphery thereof. The dial carries a stop pin 19 in the path of the arm 18 to limit the movement of the arm 18 in one direction which direction is that in which the arm 18 travels on the unwinding of the spring 14.

In the path of the arm 18, or of a manipulating handle 20 on the end of the arm, are other arms 21 radiating from a spindle 22 projecting from a switch 23, which latter is only indicated in the drawings and may be considered as of the ordinary snap switch type for the control of electric circuits.

The ordinary snap switch found on the market has four positions in a complete rotation, that is the circuit is completed twice and broken twice in the complete rotation of the switch and with such a switch there are provided four arms 21. If the switch be of another type then a lesser number of arms may answer. In the path of the arms is an elastic stop 24 so disposed that when the switch arbor 20 is turned to a position where the switch is about to move from the active to the inactive position or from the inactive to the active position, the stop 24 will hold the switch against the tendency to return to the position from which it was moved, it being common in switches of this type to turn the arbor 22 sufficiently to put a contained spring under tension before the switch member proper is released to move with great rapidity from one position to another. The purpose of the stop 24 is to

hold the switch in such position that a comparatively short movement of the arm 18 will cause the movement of the switch from its active to its inactive position or from its inactive to its active position.

Let it be assumed that it be desirable to turn electric lights on and after a predetermined time to cause the breaking of the circuit and the extinguishing of the lamps. The movable part of the switch 23 is turned so that an arm 21 is engaged by the stop 24 with the switch mechanism in a position where a slightly farther movement of the arm 21 will cause the switch to snap to the open position. In the meantime the arm 18 is moved clockwise as viewed in Fig. 1 to the desired extent winding up the spring 14 and causing the arbor-3 to move in a direction inactive to the pawl 5. When the arm 18 is released the reactive effect of the spring 14 will cause the arbor to return in the reverse direction but now the ratchet 4 will engage the pawl 5 and motion will be transmitted through the clock train. The return movement of the arm 18 under the action of the spring 14 will be only so rapid as will be permitted by the action of the escapement of the clock train so that the desired time will elapse before the arm 18 will again engage the switch actively. The relation of the smooth portion 8 of the gear 7 to the toothed portion thereof is such that the toothed portion will move out of engagement with the pinion 6 when the arm 18 has approached an arm 21 of the switch 23 so that after the expiration of the predetermined time the arm 18 is released to the full force of the spring 14 and moves with rapidity against the arm 21 of the switch 23 and the latter is actuated to the open position at once, the arm 18 being ultimately arrested by engagement with the stop 19. The relation of the smooth part 8 of the gear wheel 7 may be such that the arm 18 will begin its rapid movement under the action of the spring 14 before it reaches the switch arm 21 and therefore will deliver a hammer blow thereto.

The arm 18 may be provided with a manipulating handle adapted to engage the arms 21 or the handle may be otherwise located than shown and other means carried by the arm may be utilized for causing the actuation of the switch. Should it transpire that the switch 23 should be actuated at an earlier time than that for which the mechanism is set then an attendant may move the yoke 10 against the action of the spring 14 so as to carry the gear wheel 7 out of engagement with the pinion 6 and then the arm 12 will become immediately active under the stress

of the spring 14 and cause the actuation of the switch 23 as though released at the expiration of the time limit.

The power stored up in setting the apparatus is sufficient not only to actuate the time controlling side of the apparatus but also to actuate the devices to be set in motion after the expiration of the predetermined time.

What is claimed is:—

1. In time controlling mechanism, an arbor, a driving spring for the arbor, a dial traversed by the arbor, a mutilated gear on the arbor, a manipulating arm on the arbor for putting the spring under tension and in turn driven by the spring, a clock train in operative relation to the mutilated gear, a stop on the dial in the path of the manipulating arm, and power controlling means in the path of the arm between the point where the spring is released by the mutilated gear from the clock movement and the stop.

2. In a time controlling mechanism, an arbor, a spring secured thereto for imparting rotative movement to the arbor, a manipulating arm on the arbor for winding the spring, a dial traversed by the arbor and in operative relation to the manipulating arm, a stop on the dial in the path of the manipulating arm, retarding means for the spring and arbor, means for causing the release of the spring and arbor from the retarding means before the manipulating arm reaches the stop, and power controlling means in the path of the arm between the point where it is released from the retarding means and the stop.

3. In time controlling mechanism, a clock train, a mutilated gear in operative relation to the clock train, a pivoted frame carrying the gear, a spring tending to move the frame in a direction to maintain the gear in operative relation to the clock train, an arbor mounted in the frame and constituting a support for the gear, a spring connected to the arbor and frame and tending when put under tension to rotate the arbor, an arm on the arbor for winding the spring and in turn moved by the arbor under the action of the spring, and power-controlling means in the path of and actuated by the arm when released to the unrestricted action of the spring.

In testimony that I claim the foregoing as my own, I have hereto affixed my signature in the presence of two witnesses.

ALBERT WHITON BAILEY.

Witnesses:

J. W. WHEATLEY,
RICHARD W. ANDERSON.