

(19)



Europäisches Patentamt
European Patent Office
Office européen des brevets



(11)

EP 1 321 200 A2

(12)

EUROPEAN PATENT APPLICATION

(43) Date of publication:
25.06.2003 Bulletin 2003/26

(51) Int Cl.7: **B21D 5/02**

(21) Application number: **02028321.4**

(22) Date of filing: **17.12.2002**

(84) Designated Contracting States:
**AT BE BG CH CY CZ DE DK EE ES FI FR GB GR
IE IT LI LU MC NL PT SE SI SK TR**
Designated Extension States:
AL LT LV MK RO SI

(72) Inventor: **Mezzadri, Luigi**
29100 Piacenza (IT)

(74) Representative: **Gotra, Stefano**
Bugnion S.p.A.
Via Garibaldi 22
43100 Parma (IT)

(30) Priority: **21.12.2001 IT PR20010093**

(71) Applicant: **SCHIAVI MACCHINE INDUSTRIALI**
S.p.A.
20154 Milano (IT)

(54) **Tool in sheet metal working machine**

(57) A tool of a machine for working sheet metal comprises an operative portion (1a) destined to operate on the sheet metal, and a securing portion or spigot (1b) destined to be coupled to the machine in removable fashion, and is characterised in that the spigot (1b) has at least a ferromagnetic projecting element (3) which de-

fines an abutment surface inclined relative to the axis of the spigot, shaped in such a way as to be coupled with a magnet (5) associated to the machine. The inclination of said surface is such that the magnet exerts an attraction force with a horizontal component and a vertical component.

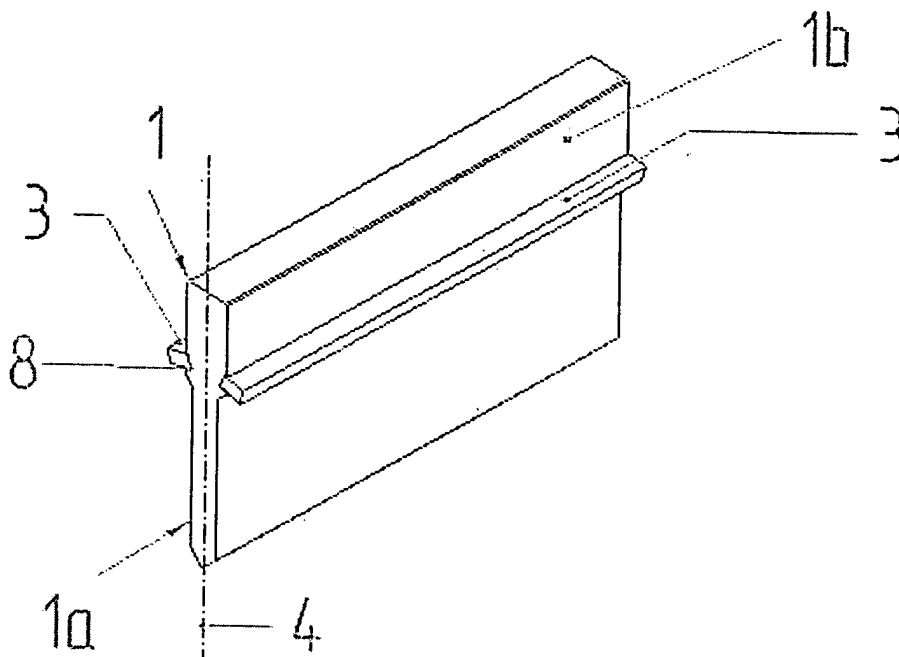

Fig. 2

EP 1 321 200 A2

Description

[0001] The present invention relates to a tool in sheet metal working machine and a sheet metal working machine that uses said tool with specific reference to a cornice brake.

[0002] Known cornice brakes comprise a fixed lower table whereon is positioned a forming die and a movable upper part where to the punches or tools are fastened in removable fashion.

[0003] The tools are locked onto the cornice brake by means of hydraulic, pneumatic or mechanical devices of a mixed type.

[0004] The Italian patent application for industrial invention number PR99A000050 by the same Applicant discloses magnetic locking means. In particular, a securing device for press tools is described which comprises means for locking the end or spigot internally to a housing of the press, constituted by one or more electromagnets.

[0005] A first electromagnet is associated to the housing of the press together with a first permanent magnet, whilst a second electromagnet and a second permanent magnet are part of device for retaining the tool. A third permanent magnet is used to guide the tool during mounting operations.

[0006] However, both the securing devices and the tool are rather complex.

[0007] In particular, the tool needs lateral millings into which the tooth of a set of pincers, which serves as a fall-preventing device, is coupled.

[0008] The press needs multiple magnets to support and guide the tool during mounting operations and, in particular, it needs electromagnets which make indispensable the availability of appropriate electromagnetic command circuits.

[0009] An aim of the present invention is to eliminate the aforesaid drawbacks making available a tool that, at the time of its locking to the machine and of its unlocking therefrom, can be held in position without falling by means of magnetic attraction exerted by permanent magnets.

[0010] An additional aim is to enable to associate a single magnet to each tool in such a way to make the tool itself extremely simple and economical, as well as functional.

[0011] A further aim is to avoid the millings on the tool, destined to interact with the teeth of the pincers.

[0012] Said aims are fully achieved by the tool of the present invention, which is characterised by the content of the claims set out below and in particular by its comprising a spigot having at least a ferromagnetic projecting element which defines an abutment surface that is inclined relative to the axis of the spigot itself and so shaped as to be coupled with a magnet associated to the machine. The inclination of said surface is such that the magnet exerts a force of attraction with a horizontal component and a vertical component.

[0013] The magnet can also be associated to the tool and the ferromagnetic surface to the machine.

[0014] This and other features shall become more readily apparent from the description that follows of a preferred embodiment illustrated, purely by way of non limiting example, in the accompanying drawing tables, in which:

- Figure 1 shows the tool according to the prior art;
- Figure 2 shows a perspective view of a first embodiment of the tool;
- Figure 3 shows the a lateral view of a second embodiment of the tool;
- Figure 4 shows a lateral view of the tool applied to a machine for working sheet metal.

[0015] With reference to Figures 2 to 4, the reference number 1 globally indicates a tool applied to a machine for working sheet metal, in the specific case a cornice brake, only partially illustrated herein.

[0016] The tool, which may have various shapes and dimensions, comprises an operative portion 1a destined to operate on the sheet metal, and a securing portion or spigot 1b destined to be coupled in removable fashion with the machine, for instance by means of appropriate pincers 2.

[0017] The spigot 1b originally has at least a ferromagnetic projecting element 3 which defines an abutment surface inclined relative to the axis 4 of the spigot, so shaped as to be coupled with a permanent magnet or electromagnet 5, associated with the machine.

[0018] The inclination of said abutment surface is about 10°-20° and preferably 15° (angle α) and in any case is such that the magnet 5 exerts an attraction force on the tool with a horizontal component and a vertical component, in such a way that not only the tool rises to abut against an upper end stop 6, but simultaneously adheres also to a later abutment 7.

[0019] The ferromagnetic projecting element 3, typically metallic, can be obtained by means of a plate inserted in a milling 8 of the spigot and fastened therein for example by means of adhesive substances, as shown in Figure 2, or it can be achieved simply by adequately shaping the spigot itself which therefore would be in a single piece, as shown in Figure 3.

[0020] The projecting element can be on only one side of the tool, or it can be symmetrical on both sides so that the tool itself can be mounted indifferently on the machine without having a preferred direction.

[0021] In the example of Figure 3, the tool has a projecting element 3 defined by the very shape of the tool, and in addition it also has a milling 8 into which can be inserted a plate to define a second projecting element.

[0022] However, the shape of the tool may also be such as to define two opposite projecting elements, for example as shown in dashed lines in Figure 3.

[0023] With the present invention, to maintain a tool in position, a single magnet applied to the machine, pref-

erably a permanent magnet, is sufficient, differently from the plurality of magnets of the prior art, which, moreover, were electromagnets and hence required the presence of an electrical circuit for their operation.

[0024] According to a different embodiment not shown herein, the magnet may be associated to the tool and the ferromagnetic surface to the machine.

[0025] If the tool is achieved as a shaped single piece, it has no millings or grooves to receive the teeth of pincers able to serve as retaining means. The retaining means are constituted by the permanent magnet which acts on the ferromagnetic surface and is more than sufficient to assure a correct positioning of the tool and prevent its fall when mounting the tool onto the machine and dismounting the tool from the machine.

Claims

1. Tool in sheet metal working machine, of the type comprising an operative portion (1a) destined to operate on the sheet metal, and a securing portion or spigot (1b) destined to be coupled with the machine in removable fashion, **characterised in that** the spigot (1b) has at least a ferromagnetic projecting element (3) which defines an abutment surface that is inclined relative to the axis (4) of the spigot, so shaped as to be coupled with a magnet (5) associated to the machine, the inclination of said surface being such that the magnet (5) exerts an attraction force with a horizontal component and a vertical component. 20
2. Tool in sheet metal working machine, of the type comprising an operative portion (1a) destined to operate on the sheet metal, and a securing portion or spigot (1b) destined to be coupled with the machine in removable fashion, **characterised in that** the spigot (1b) has at least a projecting element (3) that is magnetic or is provided with a magnet (5) which defines an abutment surface inclined relative to the axis (4) of the spigot so shaped as to be coupled with a corresponding ferromagnetic surface associated to the machine, the inclination of said abutment surface being such that the magnet (5) exerts an attraction force with a horizontal component and a vertical component. 35
3. Tool as claimed in claim 1, wherein said projecting element (3) is defined by the spigot (1b) itself, which is a single piece. 40
4. Tool as claimed in claim 1 or 2, wherein said projecting element (3) is obtained by means of a plate that is inserted in a corresponding milling (8) of the spigot (1b) said milling (8) being substantially inclined relative to the axis (4) of the spigot. 45
5. Tool as claimed in claim 4, wherein the inclination of the milling (8) is about 10° - 20°. 50
6. Tool as claimed in claim 4, wherein the spigot (1b) has two opposite millings (8) which house two corresponding plates in such a way as to make the spigot (1b) symmetrical and hence applicable to the machine with no need for frontal orientation. 55
7. Tool as claimed in claim 3, wherein the projecting element (3) is symmetrically defined on both faces of the spigot (1b). 10
8. Tool as claimed in claim 1 or 2 wherein the end of the spigot (1b) is flat or rounded. 15
9. Tools as claimed in claims 1 or 2, wherein the tool (1) has no milling (8) or lateral groove for interaction with retaining means. 20
10. Machine for working sheet metal, in particular cornice brake, of the type comprising a work table bearing a forming die whereon act tools (1) applied to a movable upper part of the machine and held thereon by appropriate pincers, **characterised in that** it comprises one or more tools (1) as claimed in any of the previous claims and one or more magnets (5) or, respectively ferromagnetic surfaces, associated to the pincers or, more generically, to the movable upper part of the machine. 25

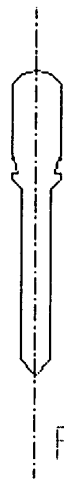

Fig. 1

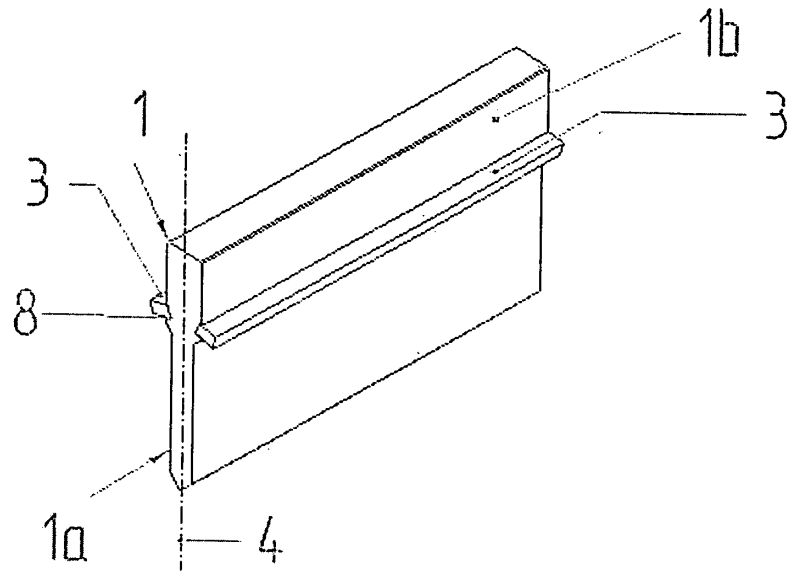

Fig. 2

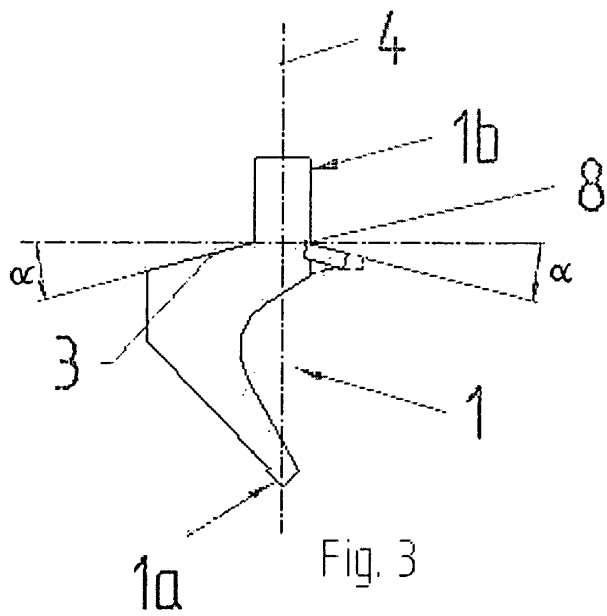

Fig. 3

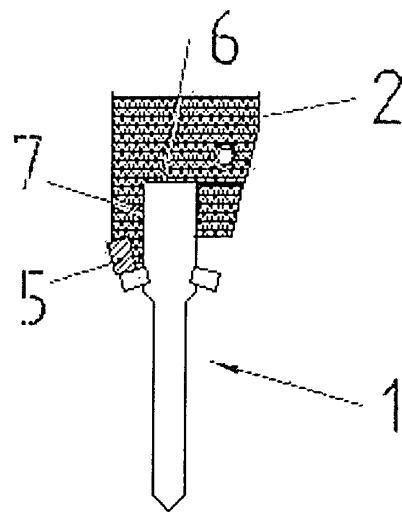

Fig. 4